

# External Review for KAGRA Interferometer Alignment Controls

Yuta Michimura

Department of Physics, University of Tokyo

[michimura@phys.s.u-tokyo.ac.jp](mailto:michimura@phys.s.u-tokyo.ac.jp)

# Background

- February - April 2020: KAGRA's first observing run (O3GK in April)
- July - October 2020: Intense commissioning period to try locking the full RSE interferometer
- During O3GK and RSE trial, we faced issues related to interferometer alignment
  - Sensitivity/stability depended very much on alignment and daily alignment procedure was not fully automated
  - Almost no ASC loops where closed, except for a few dither loops in PRC

# Purpose of this External Review

- We will present the **summary** of O3GK&RSE trial situation, and our **plans** to improve the situation, focusing on the interferometer alignment
- Are the issues we are trying to solve reasonable?
- Are our plans sound?
- What are the issues we haven't identified yet?
- What are the works we should prioritize?
- Specific questions we want to ask are written in **Question** box

# Agenda

- **Daily alignment of the interferometer [20 min]**
  - Summary of O3-RSE trial situation and our improvement plans
- **Commissioning and simulations for alignment sensing and control [40 min]**
  - Summary of current situation and plans for commissioning towards O4, focusing on global controls using wave front sensors (WFS) and QPDs
- **Input mode cleaner alignment sensing and control report [40 min]**
  - Status report from the site works and simulation activities
- <http://gwwiki.icrr.u-tokyo.ac.jp/JGWwiki/KAGRA/Subgroups/MIF/ExternalReview2021>

# **Daily alignment of the interferometer**

# Daily Alignment

- The daily alignment done using dither but not fully automated and the alignment was **not reproducible**
- We think this is one of the reasons why our interferometer lock was not reliable
  - ASC loops were also not reproducible
- For O4, we are planning several modifications to **fully automate the daily alignment** procedure

# Layout

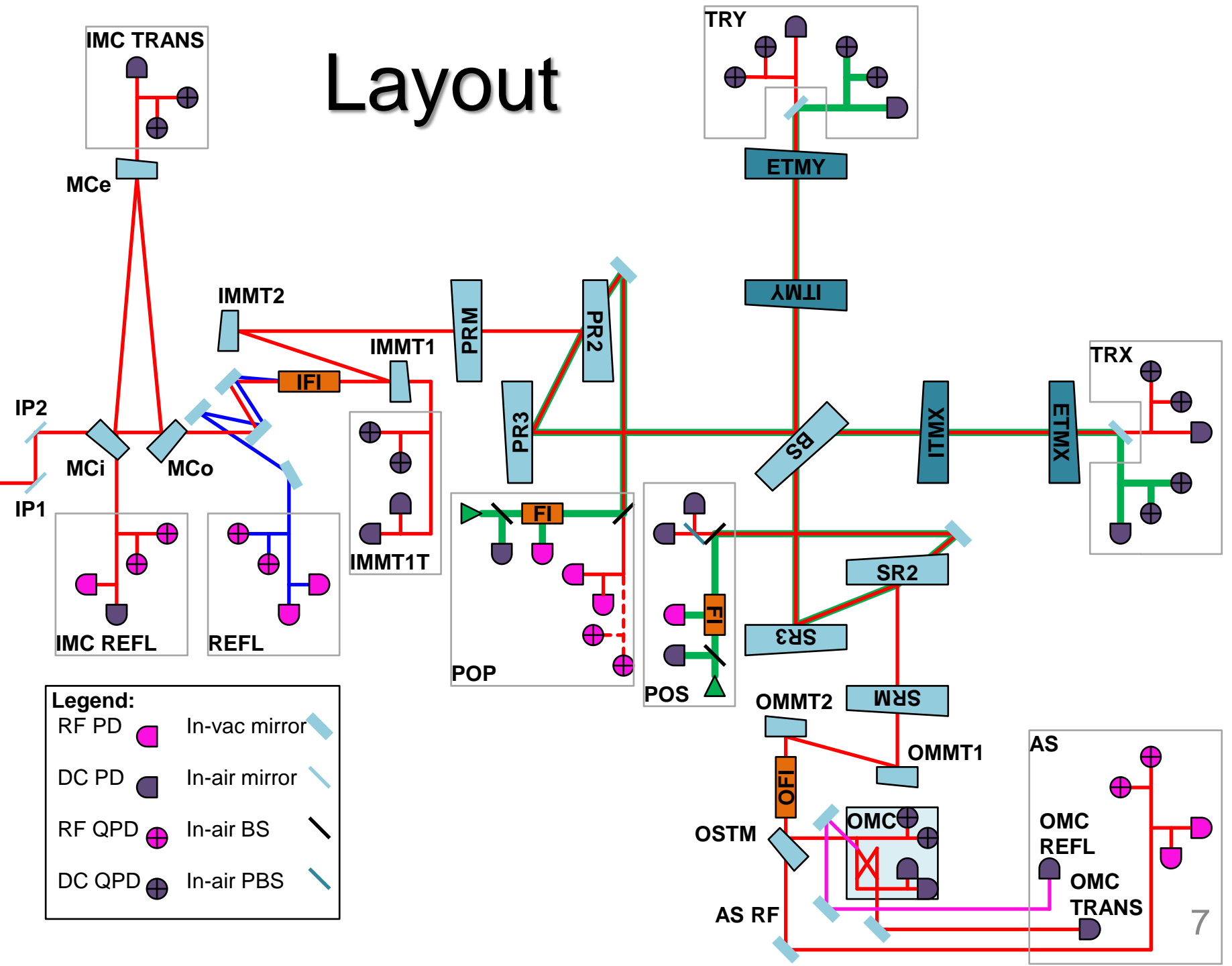

# IMC: daily alignment

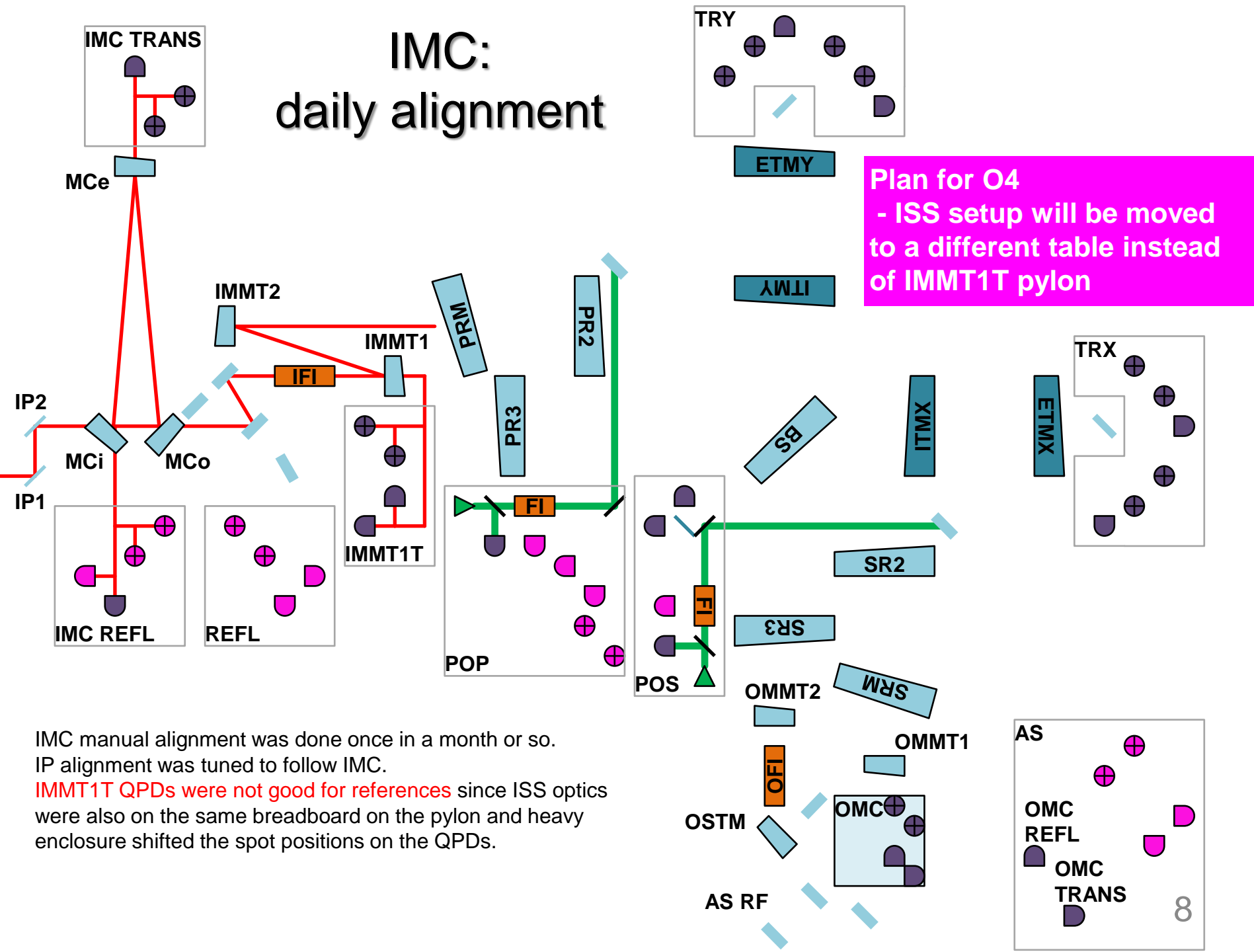

Plan for O4  
- ISS setup will be moved to a different table instead of IMMT1T pylon

IMC manual alignment was done once in a month or so.  
IP alignment was tuned to follow IMC.  
IMMT1T QPDs were not good for references since ISS optics were also on the same breadboard on the pylon and heavy enclosure shifted the spot positions on the QPDs.



# Xarm: Green alignment

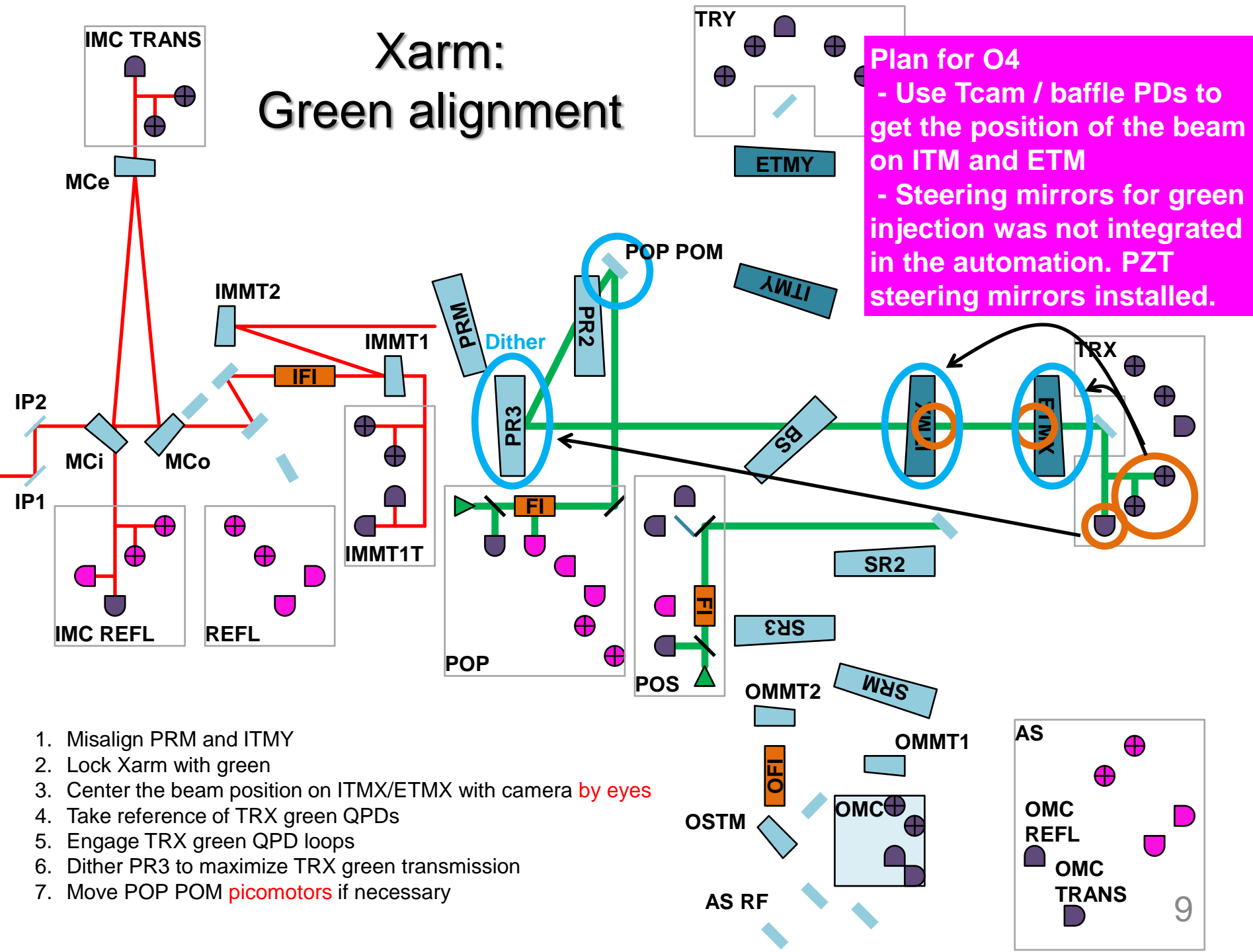

# Xarm: IR alignment

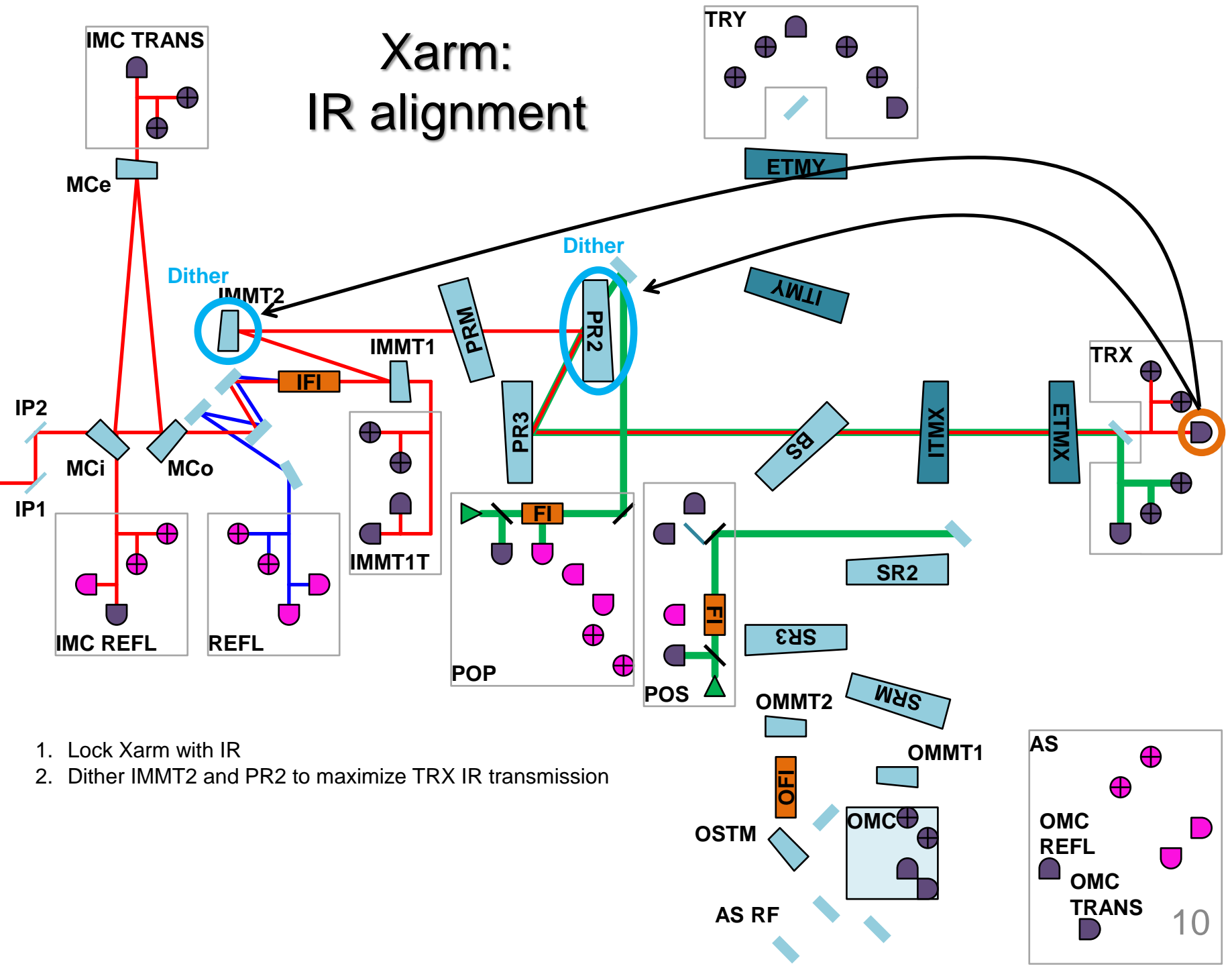

# PRMI: IR alignment

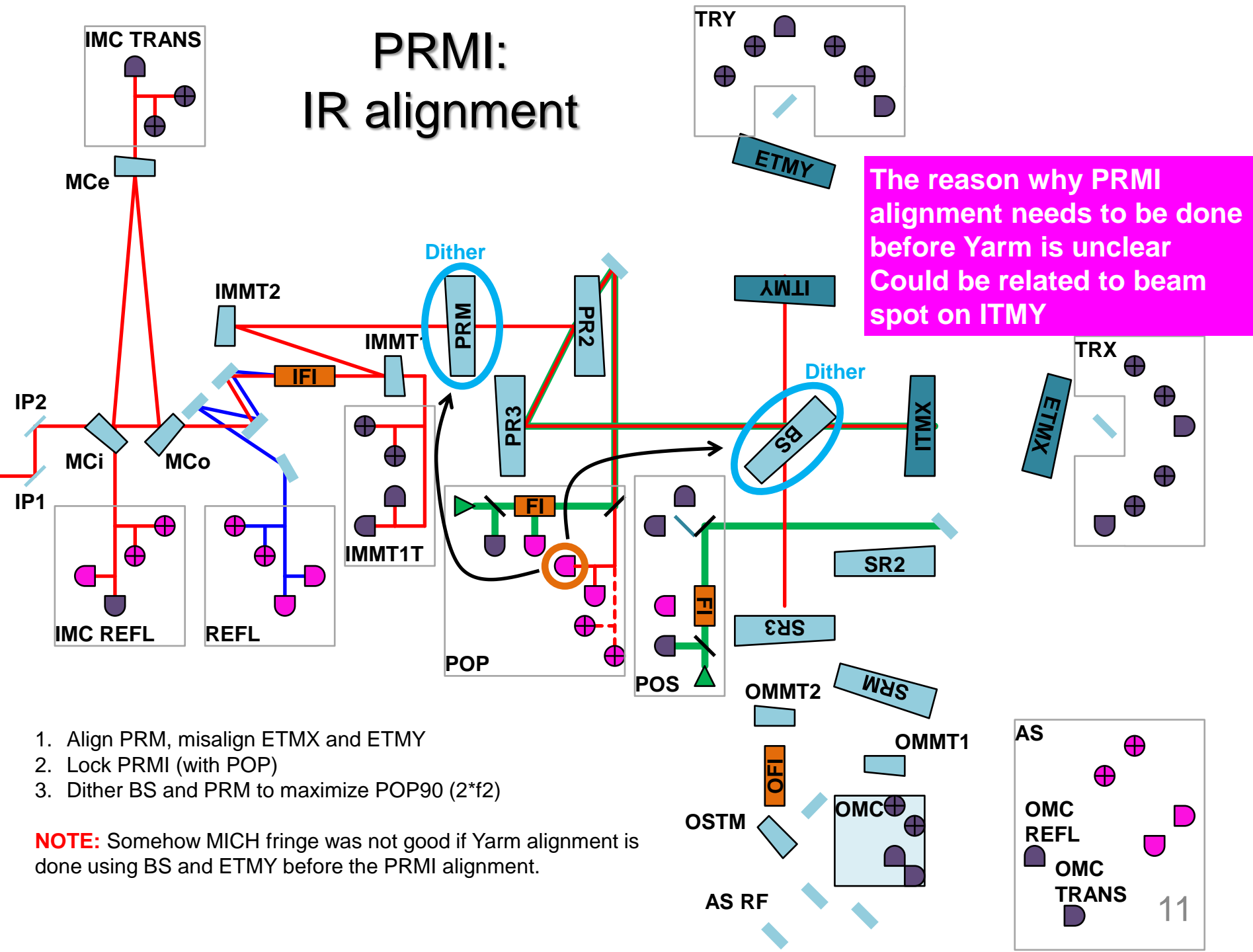

The reason why PRMI alignment needs to be done before Yarm is unclear. Could be related to beam spot on ITMY

1. Align PRM, misalign ETMX and ETMY
2. Lock PRMI (with POP)
3. Dither BS and PRM to maximize POP90 ( $2 \times f_2$ )

**NOTE:** Somehow MICH fringe was not good if Yarm alignment is done using BS and ETMY before the PRMI alignment.

# Yarm: IR alignment

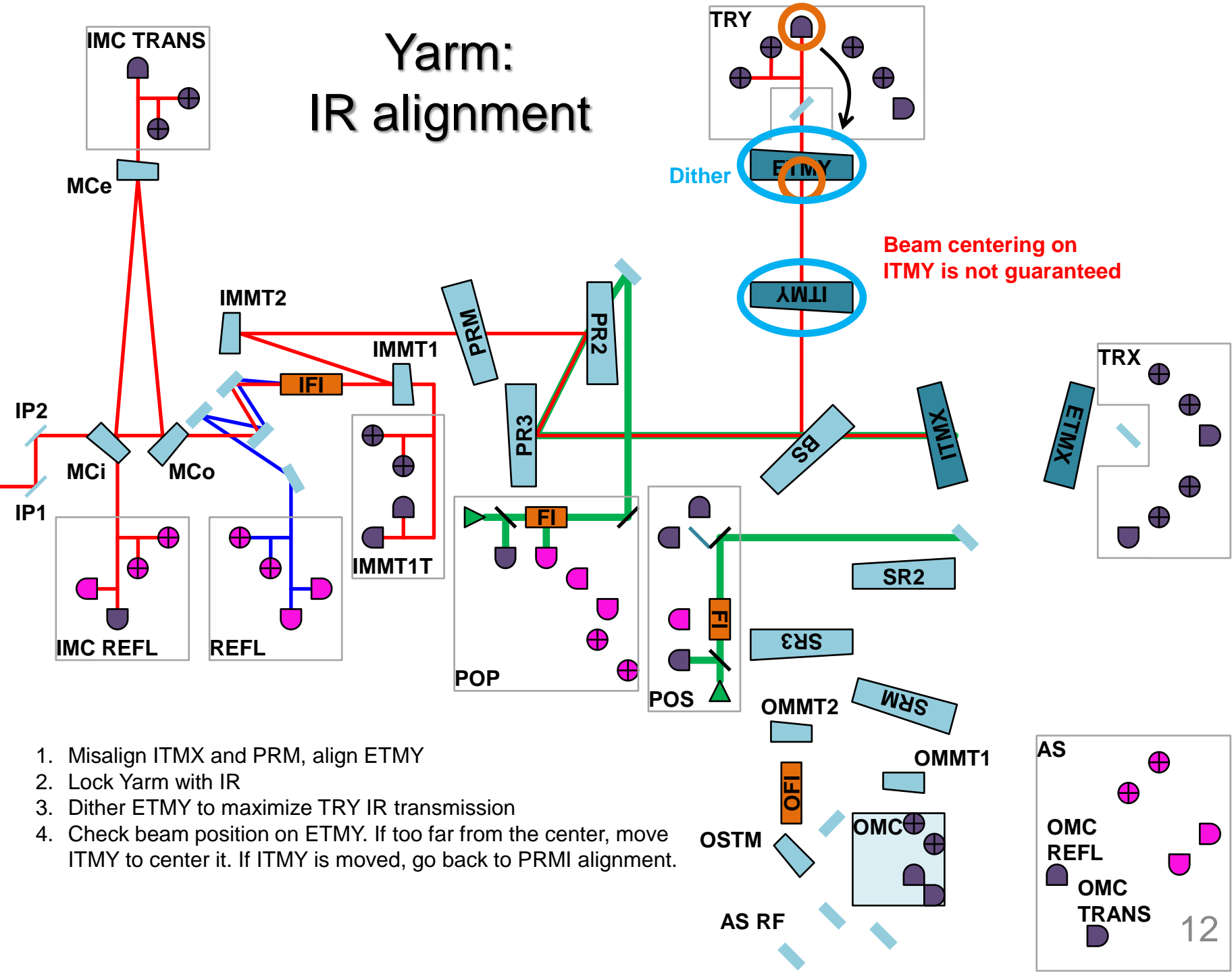

1. Misalign ITMX and PRM, align ETMY
2. Lock Yarm with IR
3. Dither ETMY to maximize TRY IR transmission
4. Check beam position on ETMY. If too far from the center, move ITMY to center it. If ITMY is moved, go back to PRMI alignment.

# Yarm: Green alignment

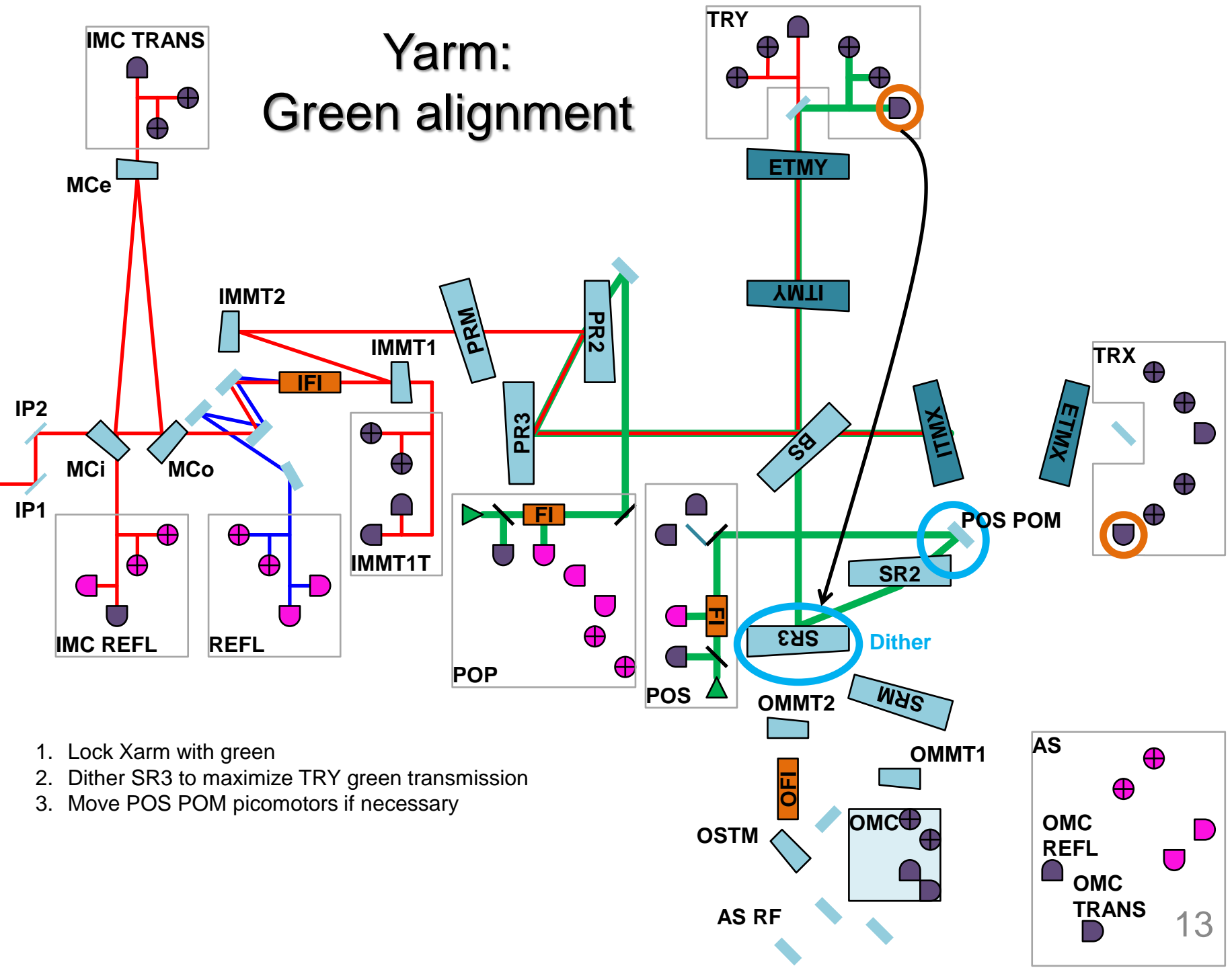

# OMC: IR alignment

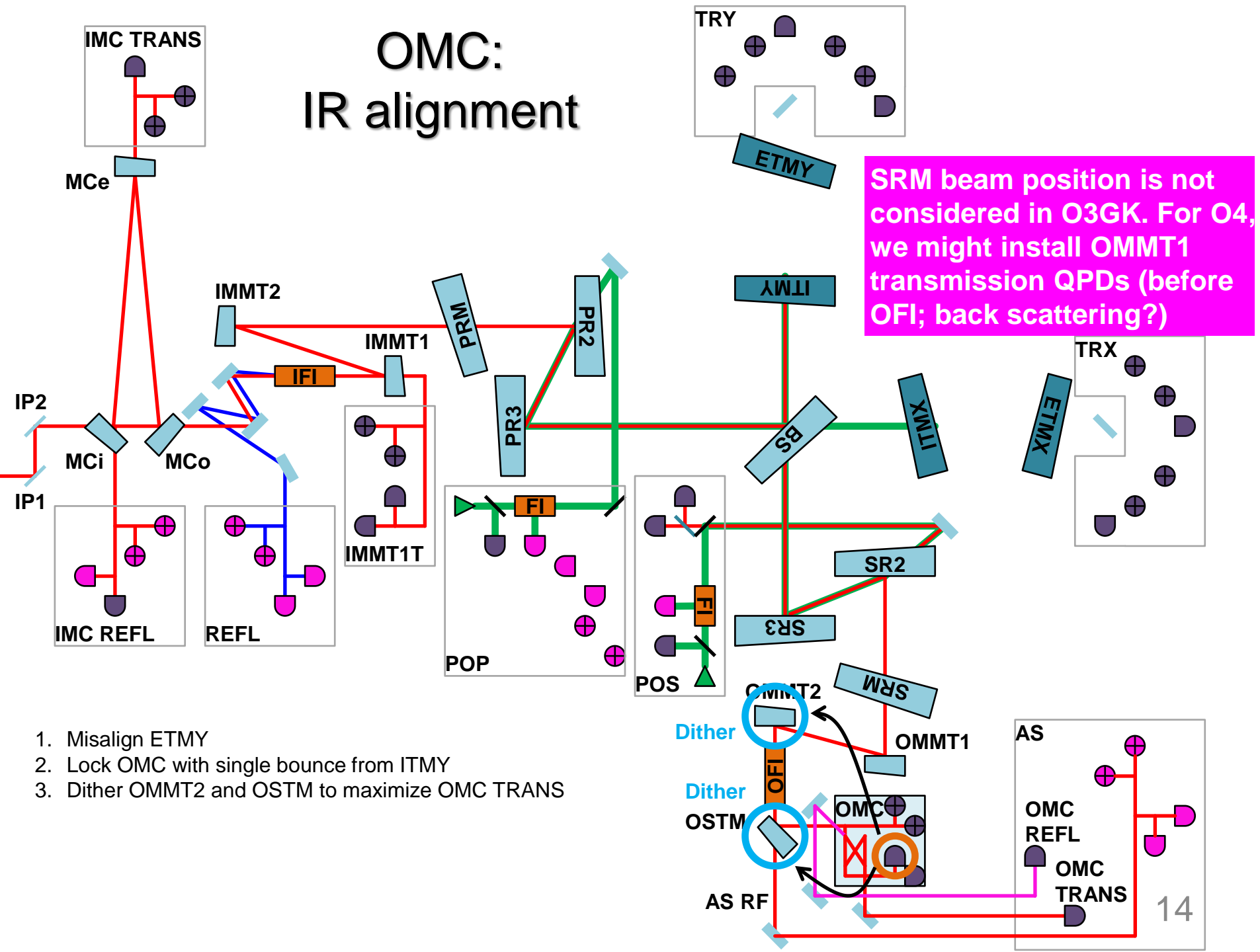

SRM beam position is not considered in O3GK. For O4, we might install OMMT1 transmission QPDs (before OFI; back scattering?)

1. Misalign ETMY
2. Lock OMC with single bounce from ITMY
3. Dither OMMT2 and OSTM to maximize OMC TRANS

# Summary of Known Issues & Plans

- **PRMI alignment was done before Yarm alignment**
  - Unclear reasons. Could be related to the beam spot in ITMY. Further investigation necessary.
- **Beam positioning on SRM was not considered so far**
  - We might be able to use OMMT1 transmission to monitor the beam position. We need investigation for available space. We might suffer from back scattering since we don't have an OFI before OMMT1.
  - Dither and SRM HR camera are also candidates, but HR camera might not be useful after mid-baffle installation.
- **IMMT1 trans QPDs were not reliable since they were on the same pylon table with ISS setup with heavy enclosure.**
  - ISS setup will be moved to a different table
- **Beam centering on ITMs and ETMs was done by our eyes.**
  - We made a script to give the position of the beam (center of the brightness) in the monitoring camera (Tcam) images of the HR surfaces. We are thinking of using this to center the beam on ITMs and ETMs automatically.
  - We will also restore baffle PDs on narrow angle baffles.
- **Actuators for steering mirrors for green steering mirrors were not included in the automation**
  - Replace two steering mirrors with piezo and picomotor actuated ones. Use piezo for daily alignment and picomotor for off-loading the piezo feedback.

Any other  
improvement  
ideas?

# **Commissioning and simulations for alignment sensing and control**



# Commissioning Status

- All in-air WFS and QPDs are mostly installed  
There are no WFS and QPDs in-vac, except for OMC QPDs
- Beam shape in **POP was ugly** and POP WFS not commissioned at all
- **TRX** QPDs had strange **pitch and yaw coupling**
- Some WFS and QPD loops were closed, but were **not stable enough** to implement them in the guardian.

We suspect that linear ranges are too small and/or zero-crossing points are dependent on the interferometer alignment (see [PhysRevD.100.082005](https://arxiv.org/abs/1008.2005)). We hope we can improve the situation once we establish reproducible daily alignment procedure.

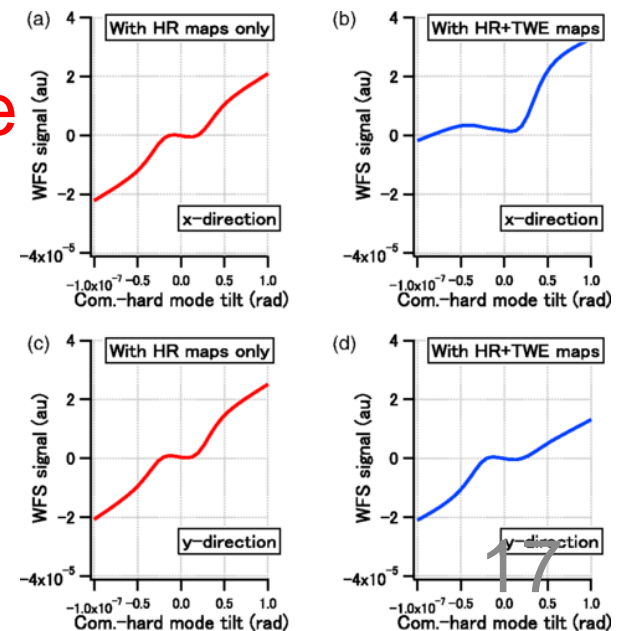
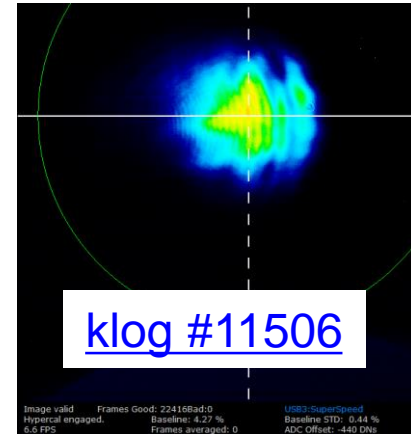

# WFS/QPD Loops “Closed”

- **IMC:** Works fine but turned off during O3GK due to excess noise
- **Xarm:** REFL RF17 for SOFT/HARD closed
- **Yarm:** TRY QPD for SOFT closed
- **PRMI:** REFL RF45 for PRM and PR3, AS RF28 for BS closed
- **DRMI:** Only dither loops once successful
- **FPMI:** REFL RF17 for DETM/CETM closed, AS RF28 for BS closed
- **PRFPMI:** AS RF for DETM almost closed, but didn't have much further time
- Commissioned **relatively well for IMC, PRMI and FPMI**, but not for PRFPMI and DR

# Simulation Status

- **Optickle**
  - FPMI, PRFPMI, SRFPMI, DRFPMI (BRSE) sensing matrix simulations with imperfections done ([JGW-T1910359](#))
  - PRMI, DRMI simulations, implementation of f2-f1 signals not yet
- **FINESSE**
  - For LSC without mirror maps, GUI for simulations with any interferometer configurations done ([JGW-T2012132](#))
  - Working on ASC integration
  - Also input mode cleaner (IMC) ASC simulations and analytical calculations on going independently
- We are thinking of **focusing on FINESSE simulations** to implement birefringence effects ([JGW-G2012222](#))

# FINESSE Birefringence Model

- S-pol and P-pol, two-world approach
- Working on generating a birefringence map from rotated TWE maps ([JGW-T2112852](#))

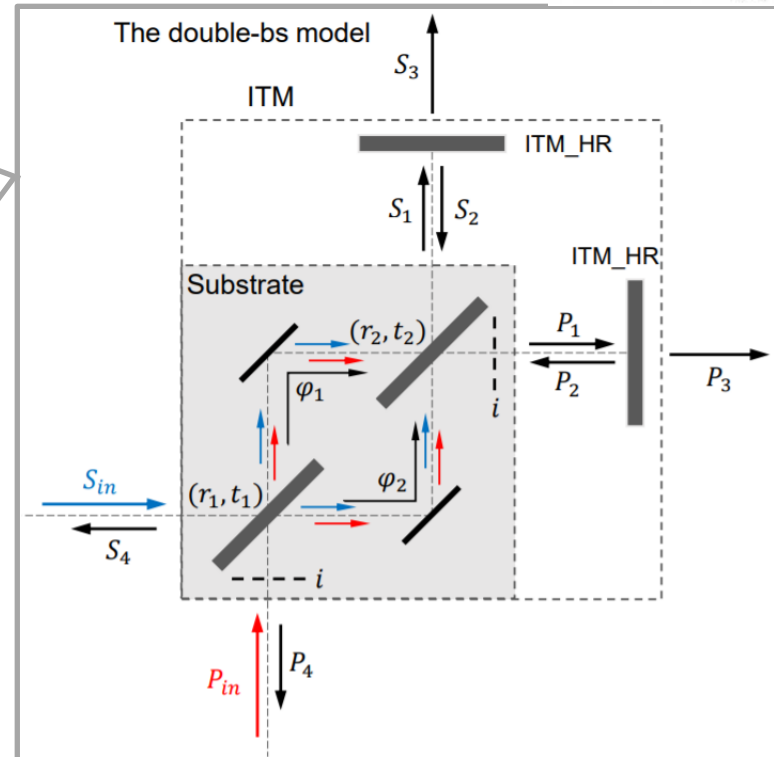
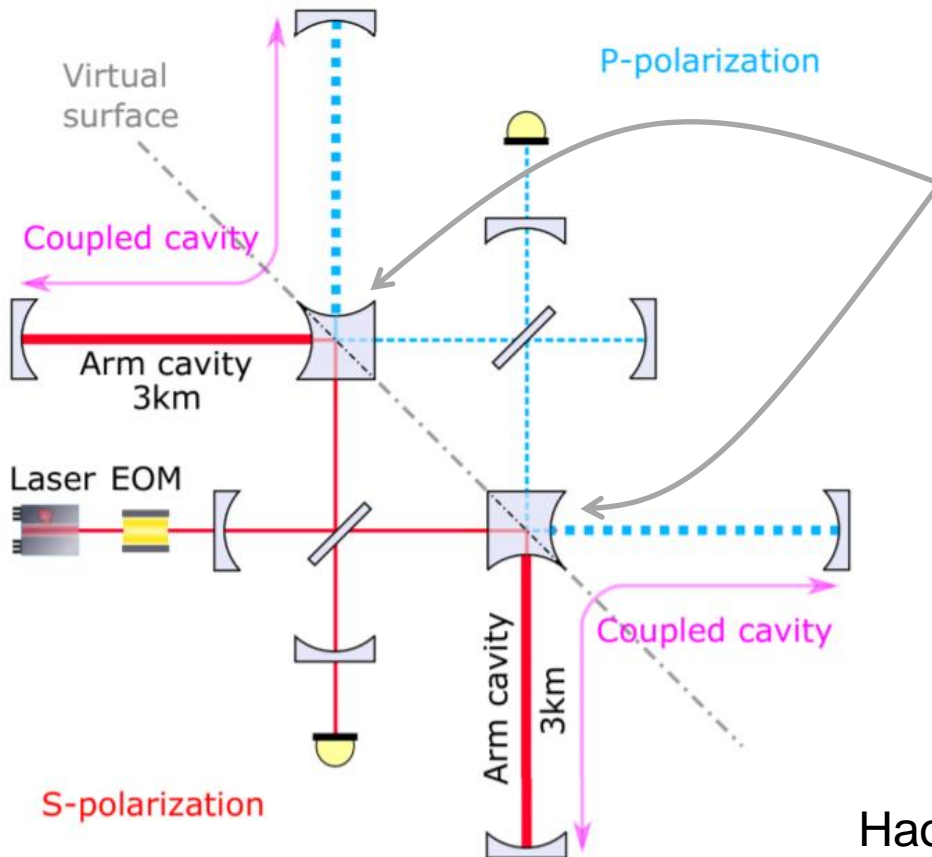
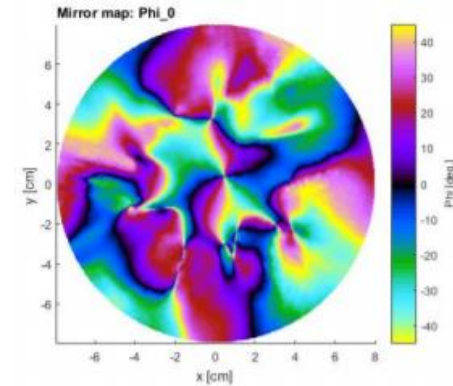

# Strategies for O4 ASC

- Issues in O3GK-RSE trial
  - Previous commissioning focused mostly on LSC and noise hunting
  - Little time was occasionally allocated for ASC where there was some spare time
  - Interferometer commissioners spent most of the time settling down the suspensions
- For O4, we will make **specific commissioning time slots for ASC**
- We also **clarify the requirements for local damping** and require suspension commissioning team to achieve them
- **Suspension experts** are expected to be present at the control room during the interferometer commissioning period

# Requirements for Local Damping

- **ITMs and ETMs (Type-A)**

  - <240  $\mu\text{m}/\text{sec}$  (for arm green locking) [KO]

  - <0.44  $\mu\text{m}/\text{sec}$  (for central part locking) [TS]

  - <0.1  $\mu\text{rad}$  RMS [YM2]

- **BS (Type-B)**

  - <1.6  $\mu\text{m}/\text{sec}$  [YM1]

  - <1  $\mu\text{rad}$  RMS [YM2]

- **SRs (Type-B)**

  - <0.44  $\mu\text{m}/\text{sec}$  [YM1]

  - <1  $\mu\text{rad}$  RMS [YM2]

- **PRs (Type-Bp)**

  - <7.3  $\mu\text{m}/\text{sec}$  [YM1]

  - <1  $\mu\text{rad}$  RMS [YM2]

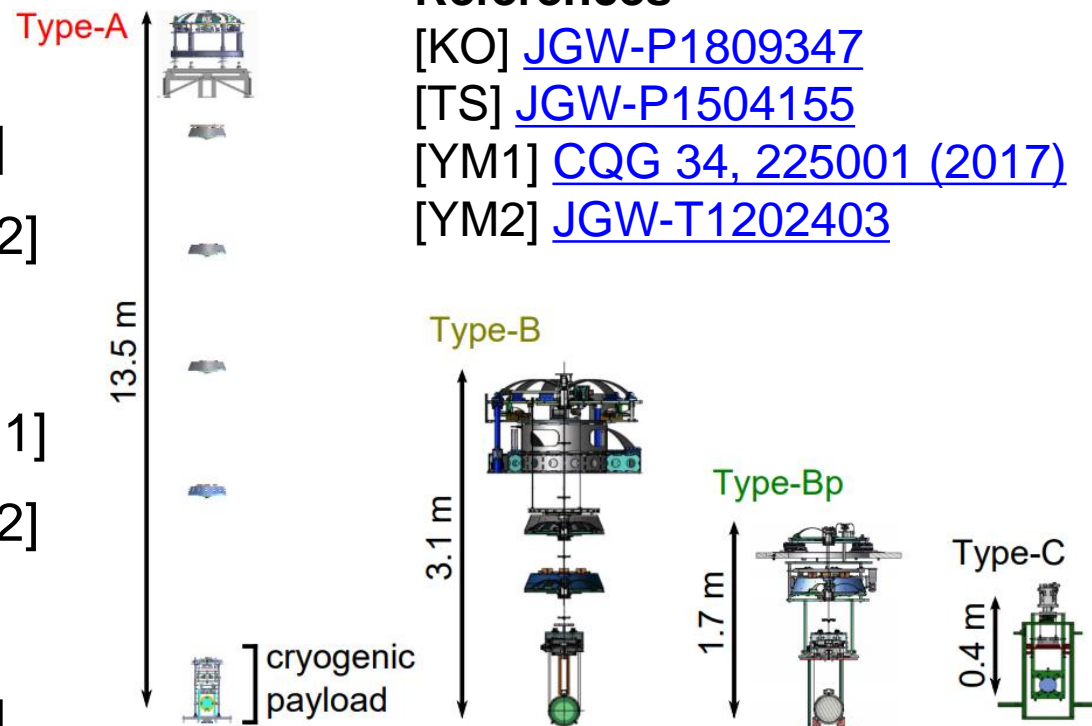

# O4 Commissioning Timeline

- Uchiyama-san

# Xarm Targets

- Find out the reasons for ugly POP beam
- Check if REFL WFS and POP WFS give consistent sensing matrices with simulations
- Align the IR and green beams to Xarm and check the positions of mid-sized baffles in PR

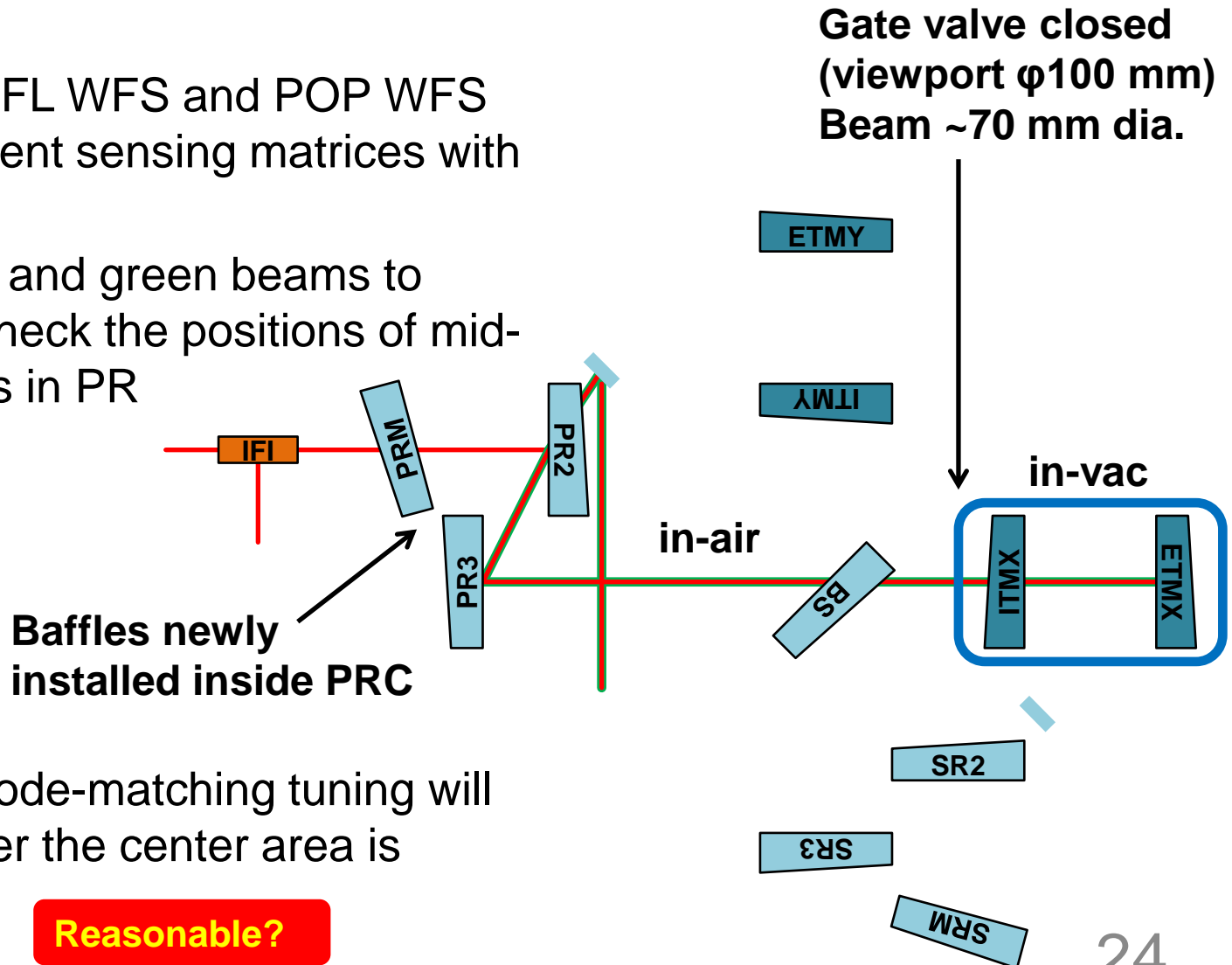

- ASC and mode-matching tuning will be done after the center area is evacuated

**Reasonable?**



# Yarm Targets

- Find out the reasons for ugly POP beam
- Check if REFL WFS and POP WFS give consistent sensing matrices with simulations
- Align the IR and green beams to Xarm and check the positions of mid-sized baffles in SR

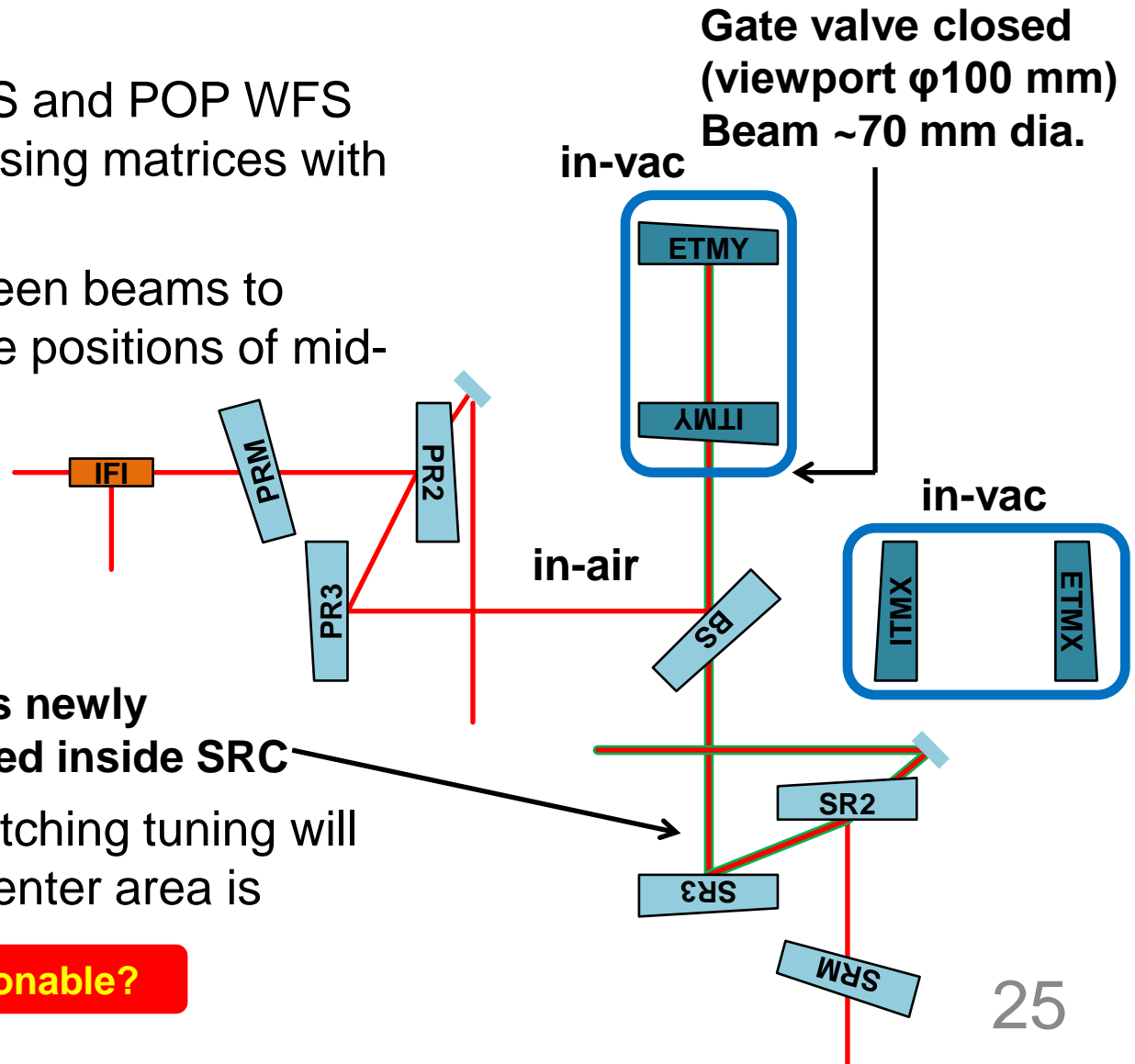

- ASC and mode-matching tuning will be done after the center area is evacuated

**Reasonable?**

# FPMI Targets

- Investigate TRX pitch and yaw coupling issue
- Check if REFL WFS, POP WFS, AS WFS and TRX QPD give consistent sensing matrices with simulations
- Check the polarization content at each port when Xarm is locked/unlocked, cross check with FINESSE (birefringence) model
- Mode matching ratio (including mis-alignment) of more than 90% for both arms
- Adjust PR2 and PR3 positions at this stage?
- Hold the lock of Xarm and Yarm in IR with ASC for a duration of longer than 2 hours continuously
  - Make sure that suspension alignment drift is smaller when the ASC loops are on

**More mode matching?  
Adjust at this stage?**

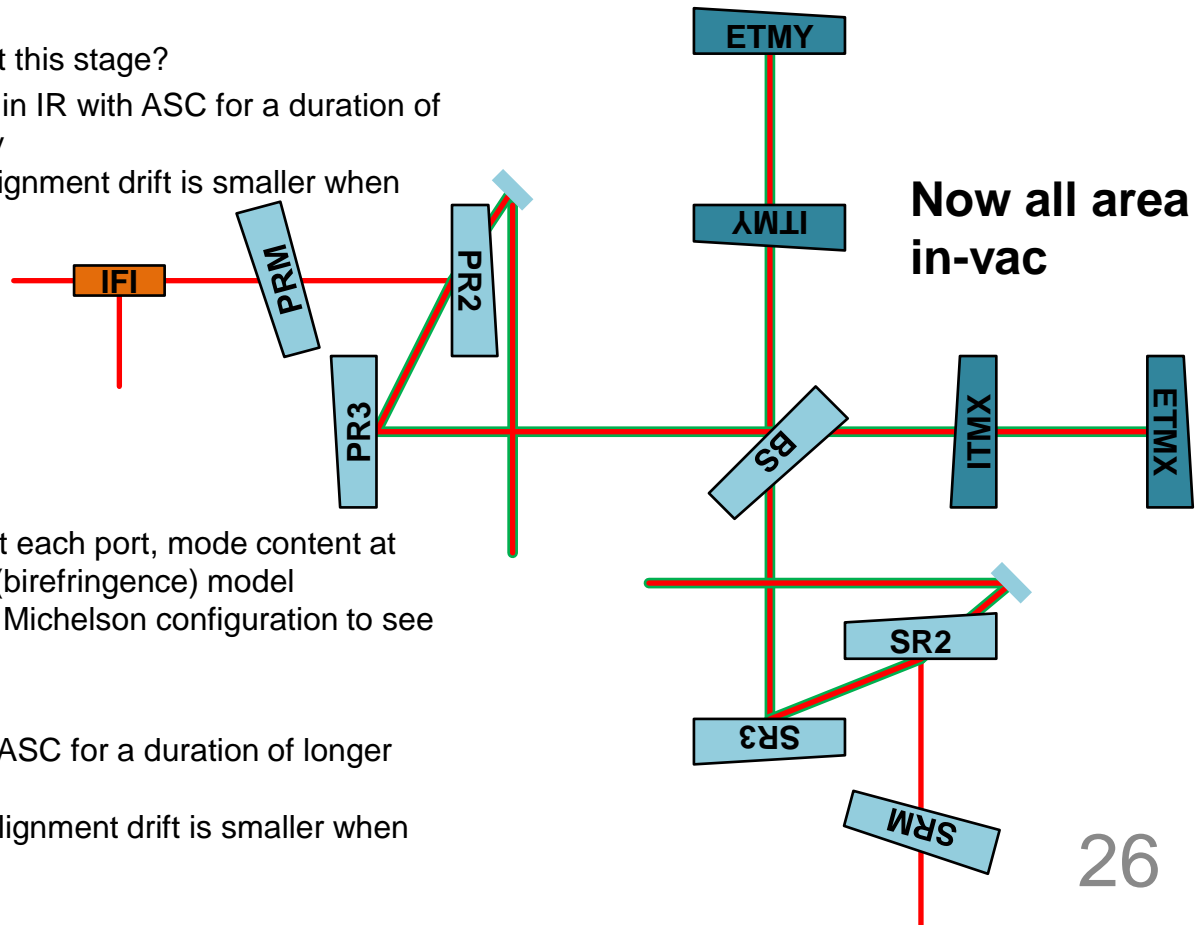

- Check the polarization content at each port, mode content at AS, cross check with FINESSE (birefringence) model
  - Compare them with a simple Michelson configuration to see Lawrence effect
- OMC alignment commissioning
- Hold the lock of FPMI in IR with ASC for a duration of longer than 2 hours continuously
  - Make sure that suspension alignment drift is smaller when the ASC loops are on

# PRMI Targets

- Check PRC Gouy phase and length (inconsistent results so far)
- Hold the lock of PRMI in 1f or 3f signals with ASC for a duration of longer than 2 hours continuously

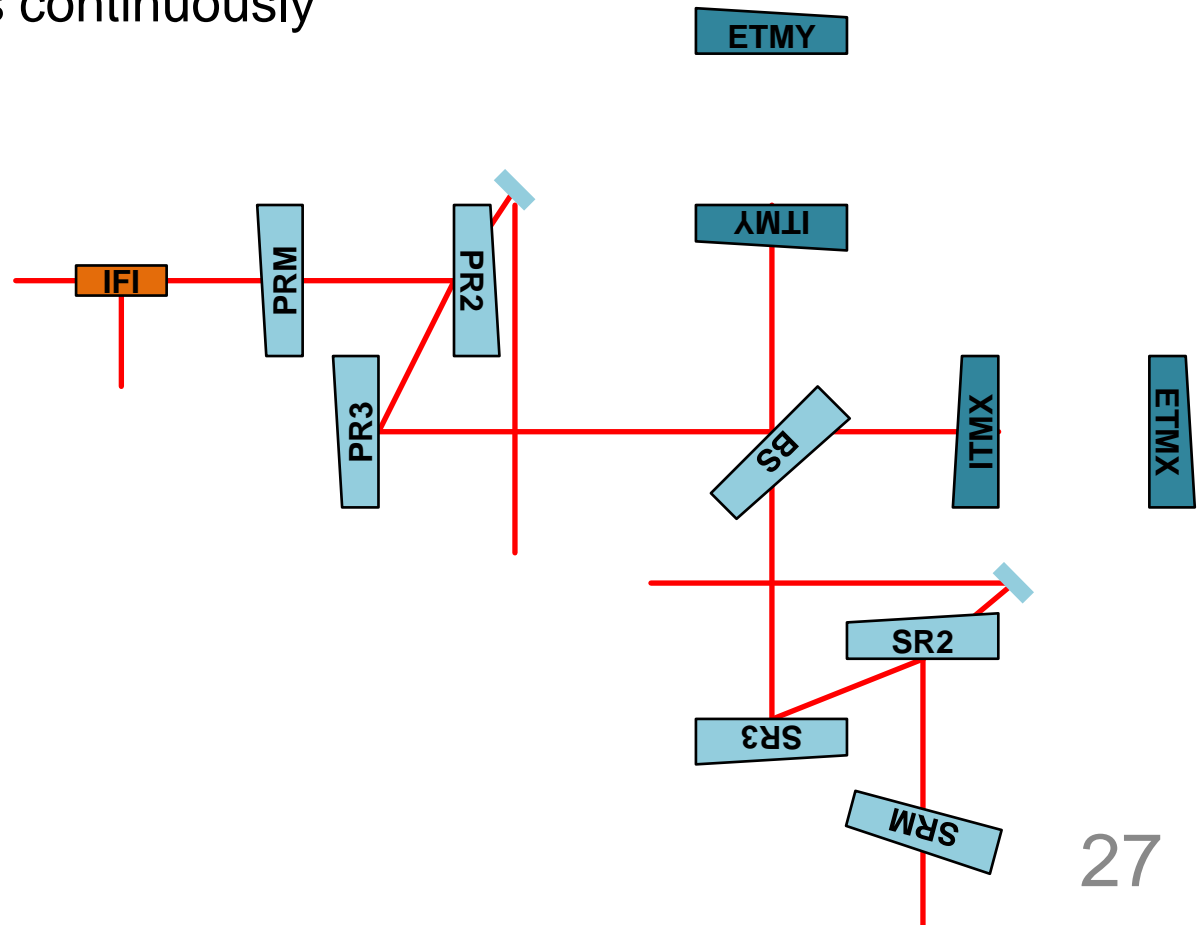

# PRFPMI Targets

- Hold the lock of PRFPMI with ASC for a duration of longer than 2 hours continuously

**SRM transmissivity?  
0% or 30%?  
Mode healing in SRC?**

- Towards DR
  - Check SRC Gouy phase and length (inconsistent results so far)
  - Examine the mode-hop criteria (Which mirror affects most and how much angular motions are tolerable)

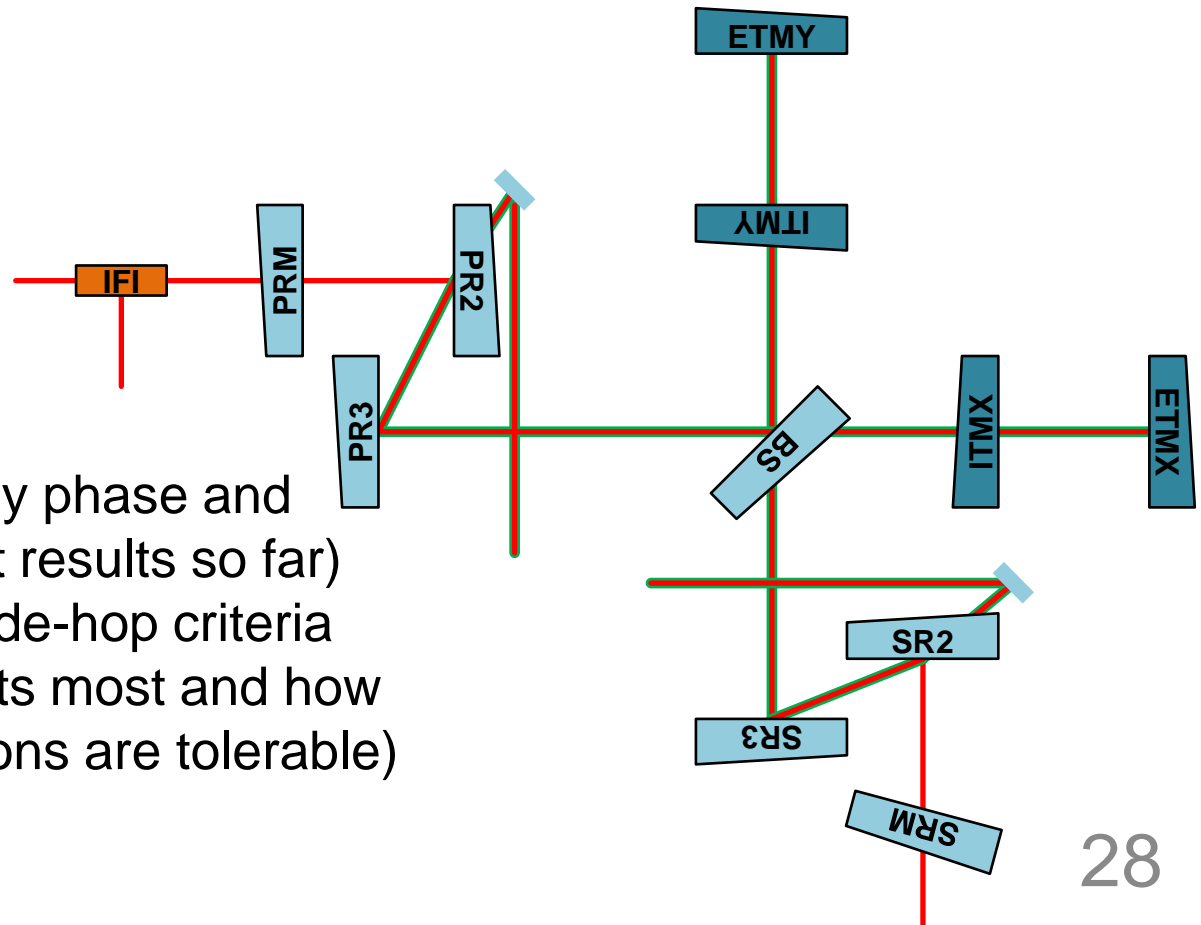

**Input mode cleaner  
alignment sensing  
and control report**

# IMC ASC Agenda

- IMC ASC status (Kenta Tanaka)
- IMC ASC sensing matrix comparison with simulations and calculations (Chiaki Hirose)