

# Expectations for Sensitivity of KAGRA in O4

Yuta Michimura

# Observing Scenario of LVK

- Best sensitivity was  $\sim 1$  Mpc although we anticipated 8-25 Mpc

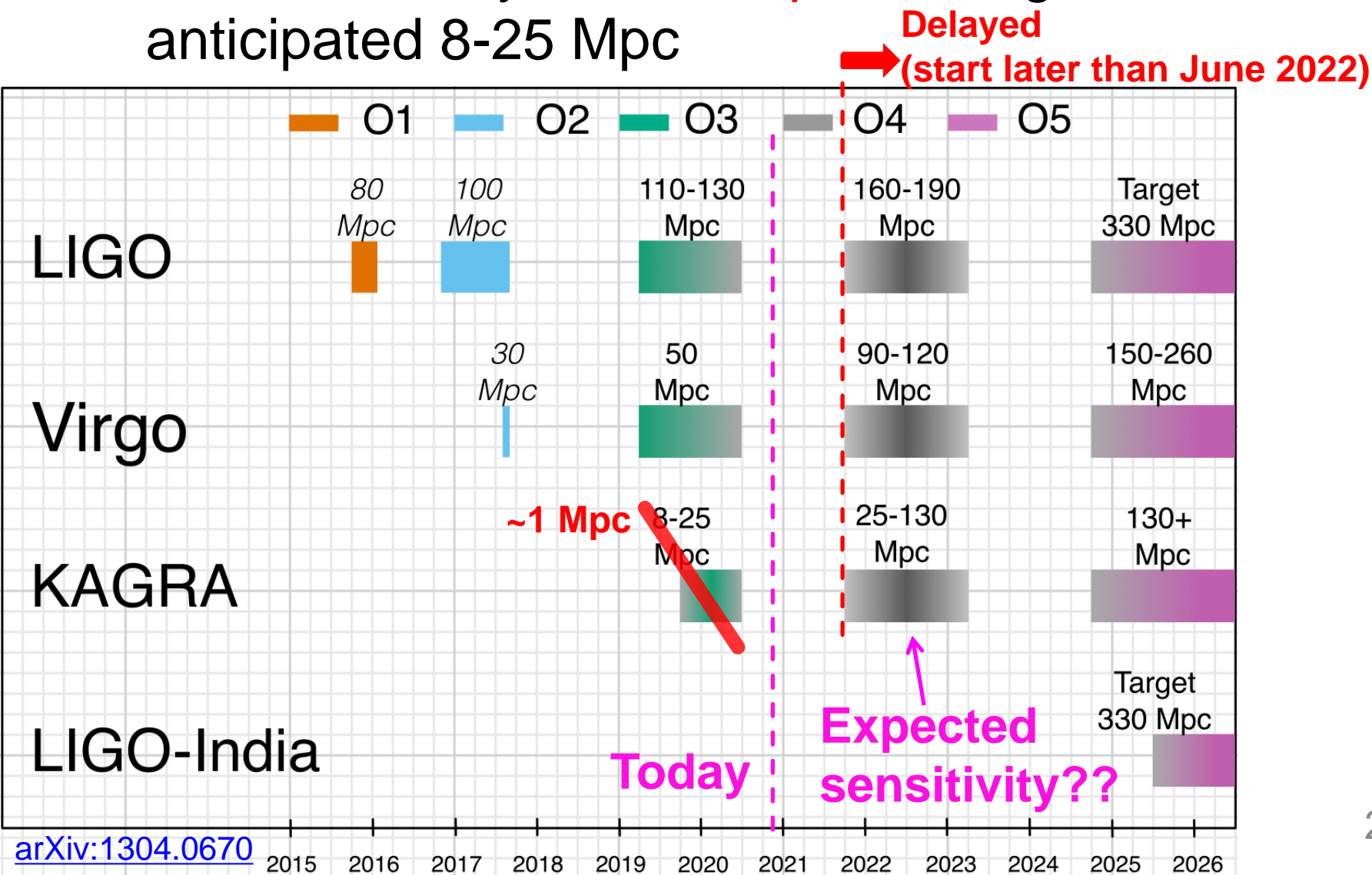

# O3GK Configuration

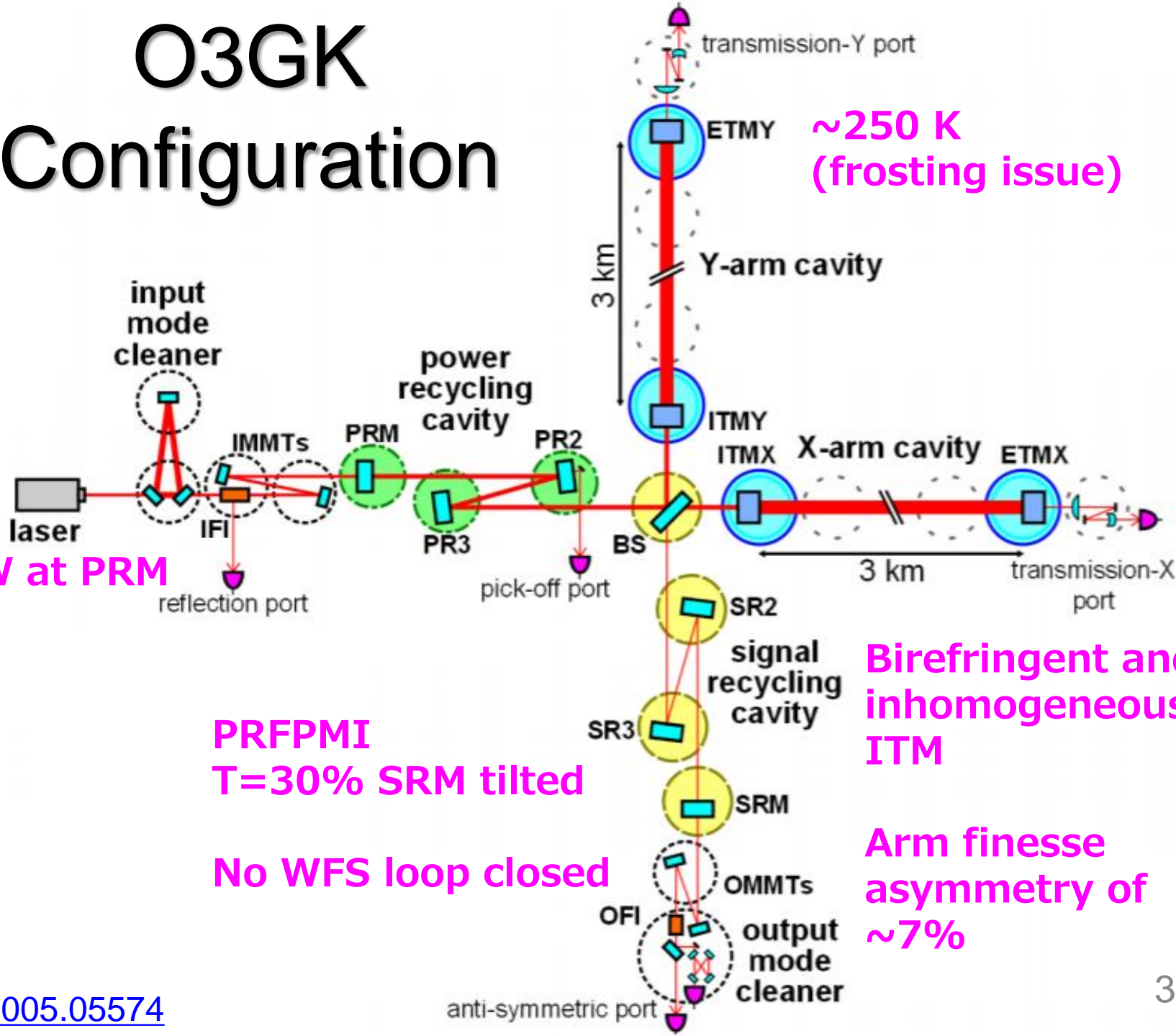

$\sim 250\text{ K}$   
(frosting issue)

3-5 W at PRM

PRFPMI  
T=30% SRM tilted

No WFS loop closed

Birefringent and inhomogeneous ITM

Arm finesse asymmetry of  $\sim 7\%$

# O3GK Noise Budget

Preliminary NB with data on April 12, 2020 (2020/12/15 ver)

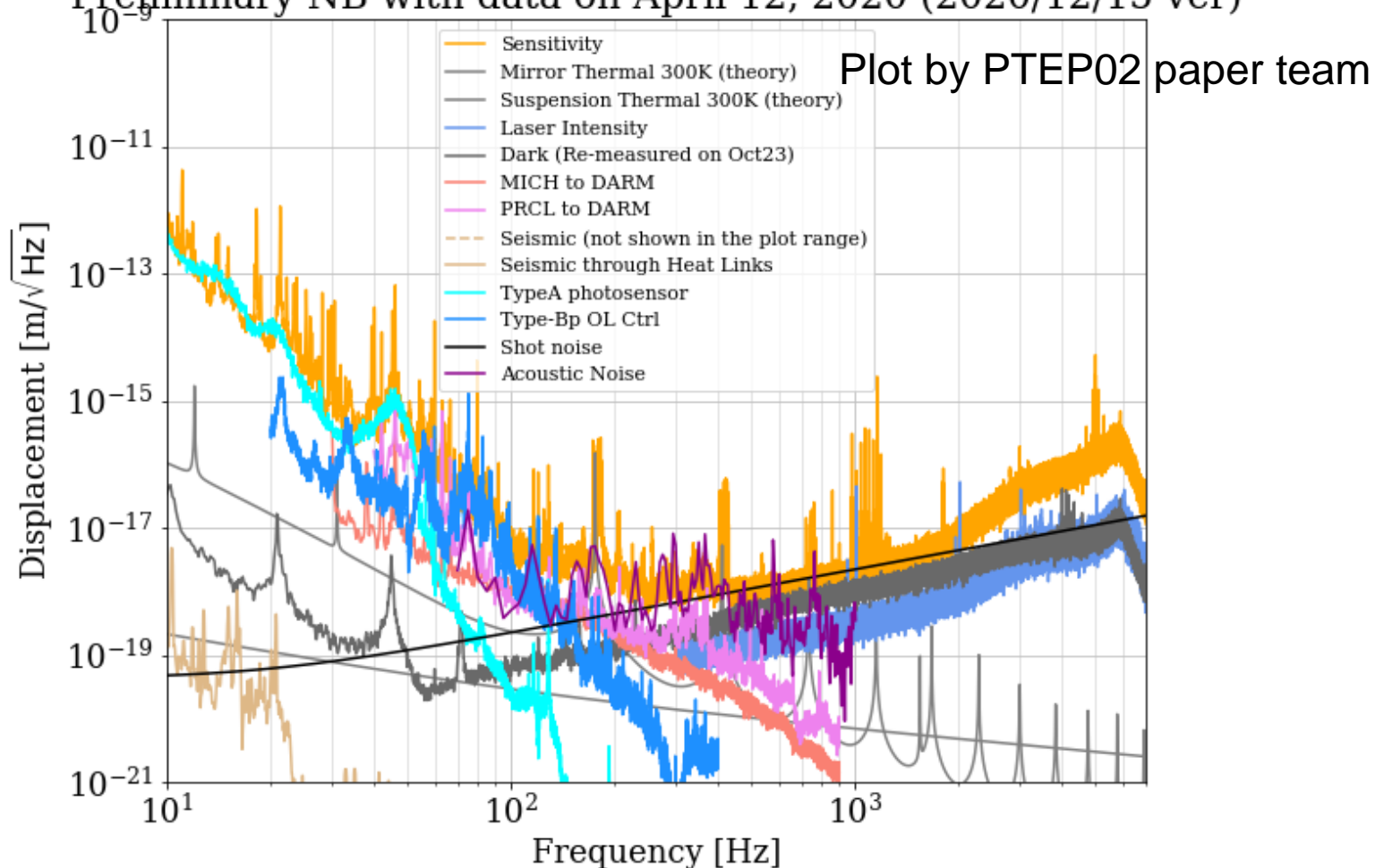

## Preliminary!

- OMC dark noise needs some update
- Frequency noise not plotted yet
- Type-B noise not plotted yet etc...

# O3GK Noise Budget

Preliminary NB with data on April 12, 2020 (2020/12/15 ver)

**Test mass suspension  
(Type-A)  
damping noise**

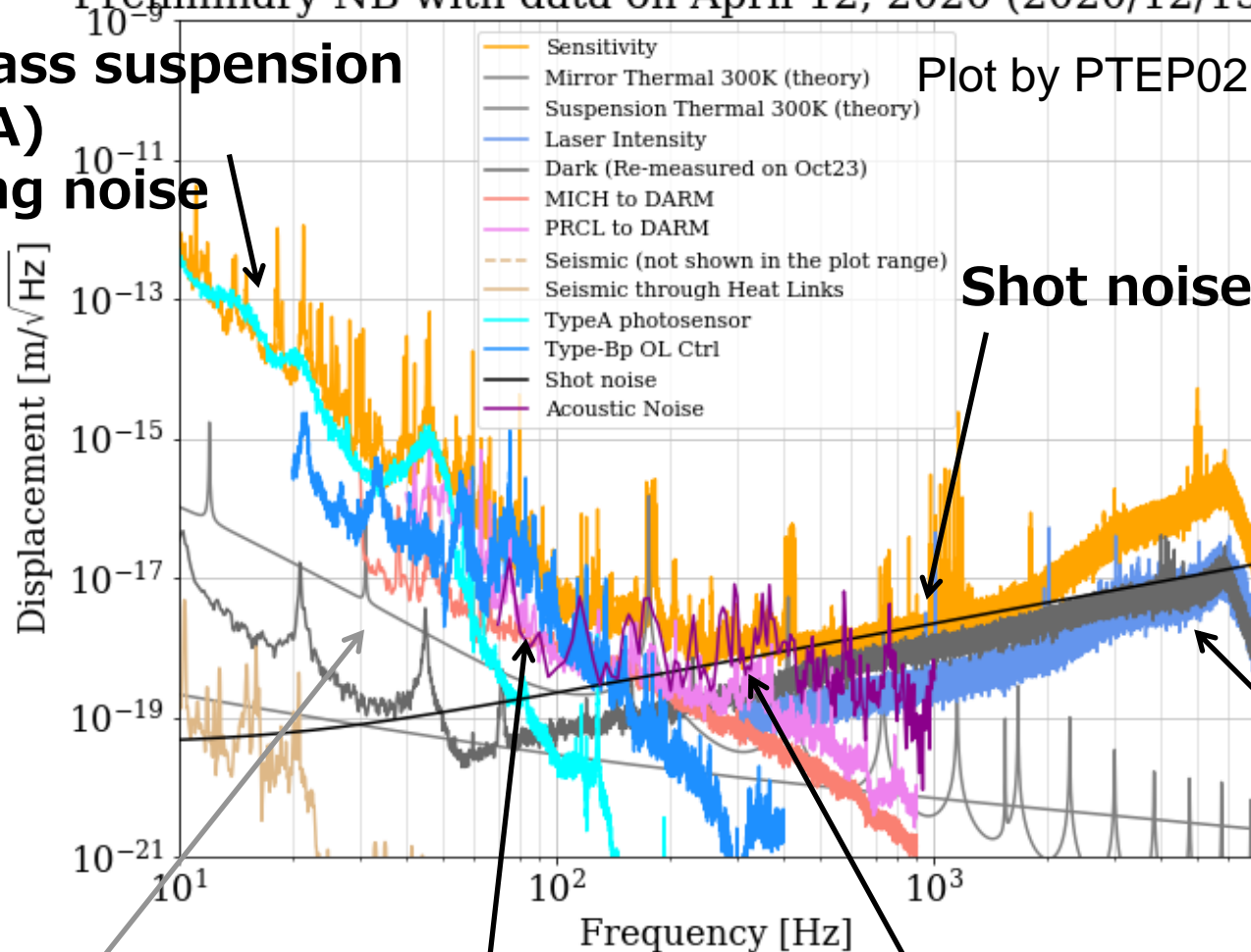

Plot by PTEP02 paper team

**Suspension  
thermal noise**

**Coupling from  
auxiliary degrees of freedom**

**Acoustic noise**

**Laser noises**

# O4 Target

- We need to reduce excess noise at  $\sim 100$  Hz at least by a factor of **50**

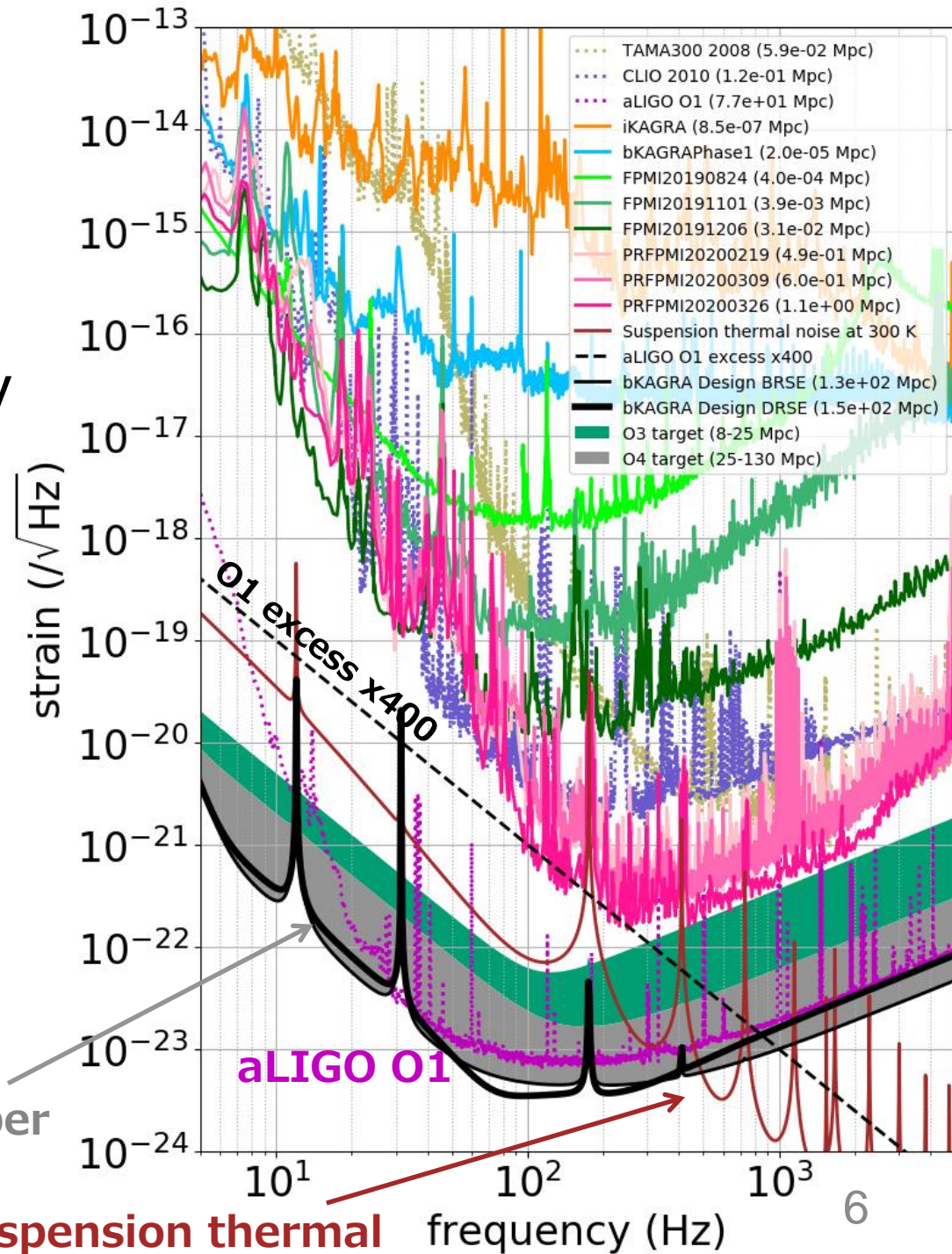

O4 target on Obs. Scenario Paper  
25-130 Mpc

# O4 “Minimum” Example

- 1/40 excess, 100 K, 50 W at BS, DR, 1/3 laser noise

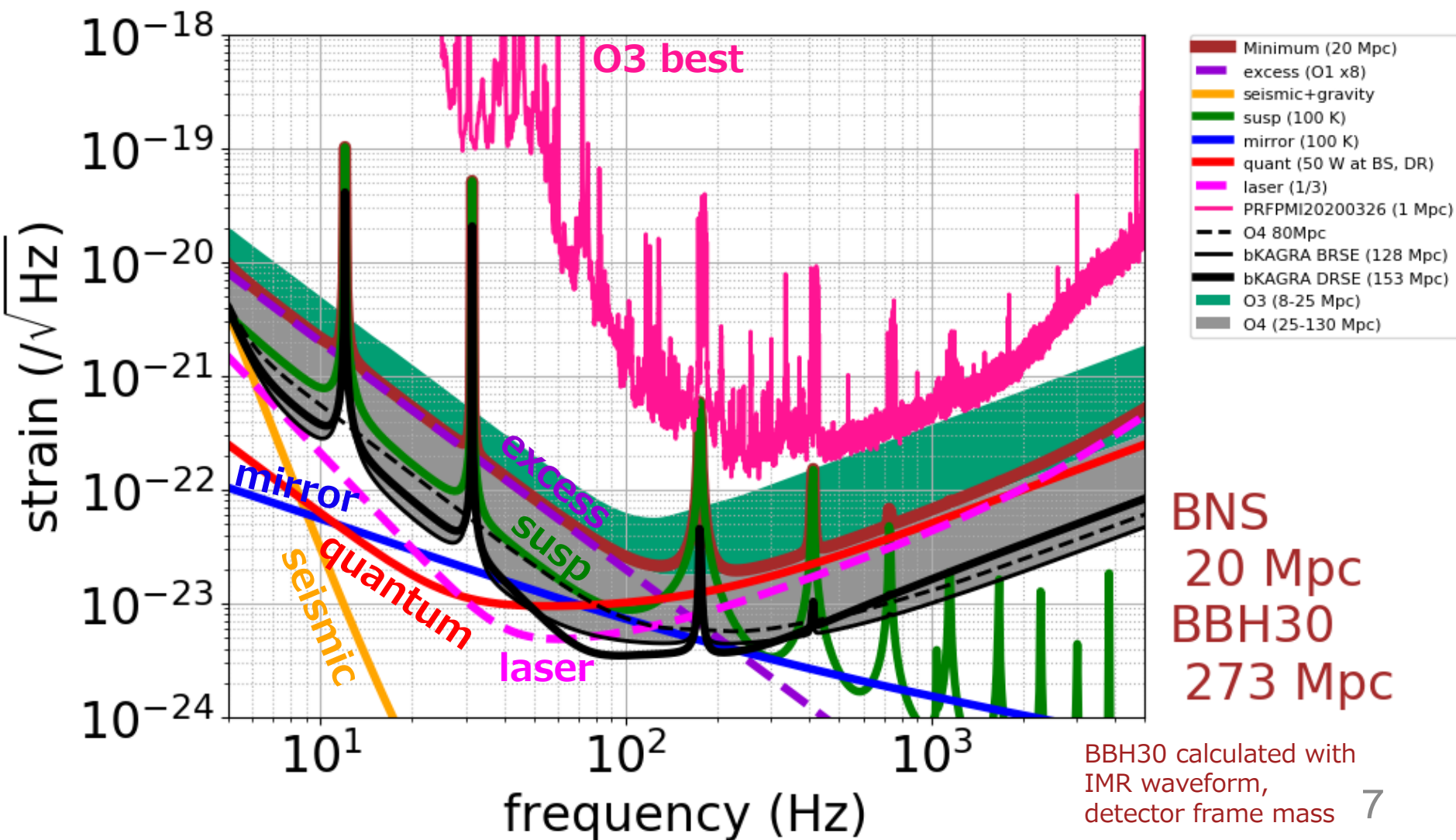

# O4 “Optimistic” Example

- 1/400 excess, 40 K, 300 W at BS, DR, 1/10 laser noise

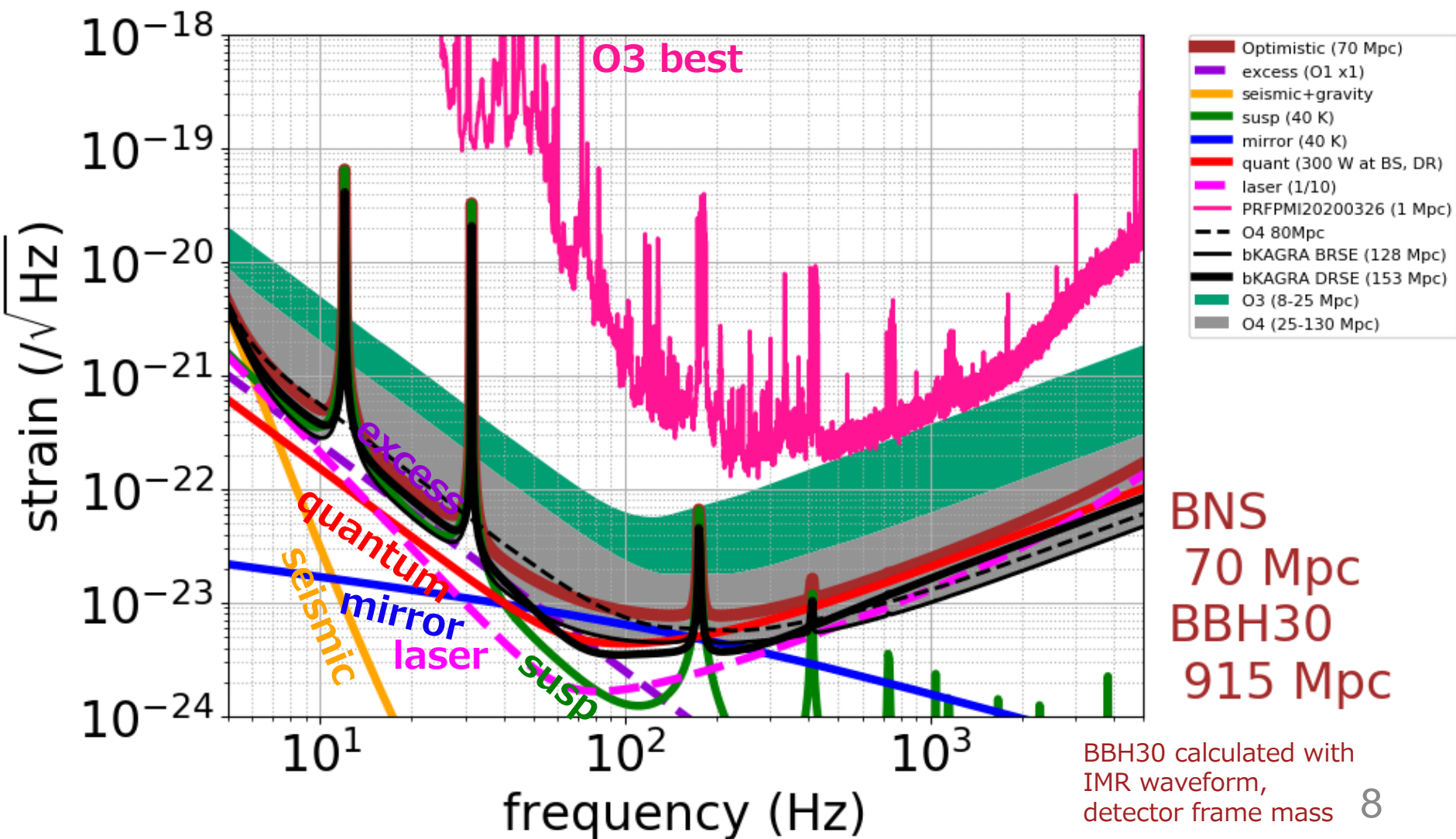



# Inspiral Range

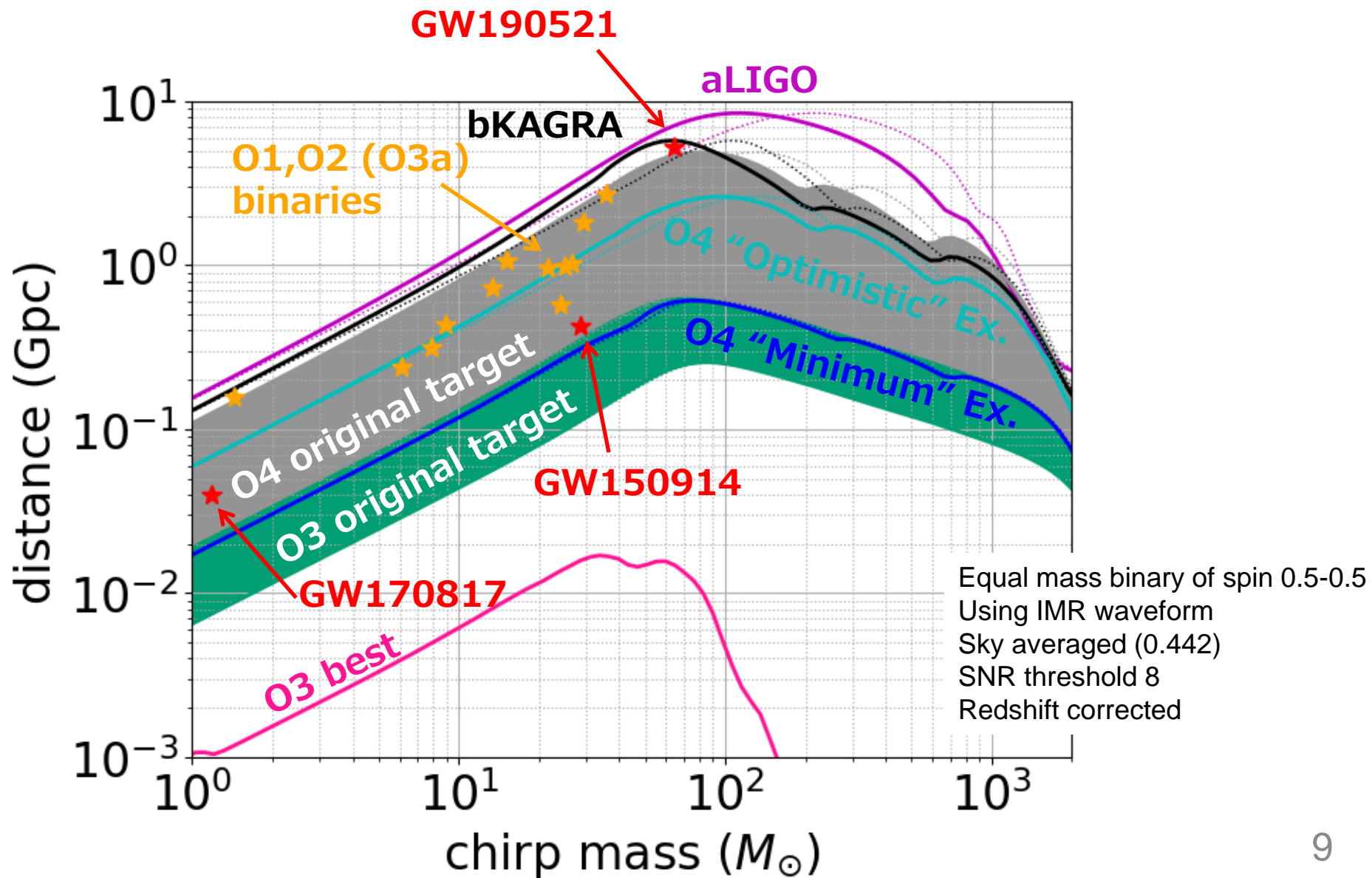

# Expectations for O4

- Laser noises (frequency noise and intensity noise)
- Shot noise
- Acoustic noise
- Coupling from auxiliary degrees of freedom
- Thermal noise
- Test mass suspension damping noise

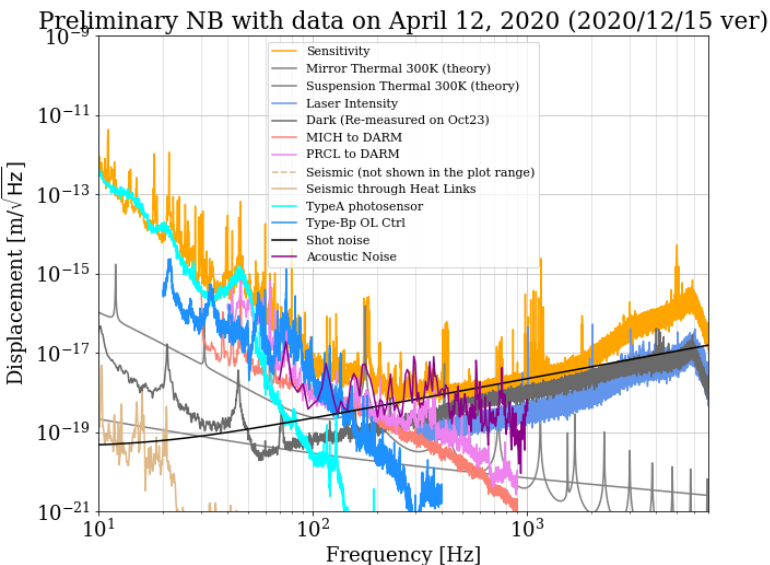

# Expectations for O4

- Laser noises (frequency noise and intensity noise)
- Shot noise
- Acoustic noise
- Coupling from auxiliary degrees of freedom
- Thermal noise
- Test mass suspension damping noise

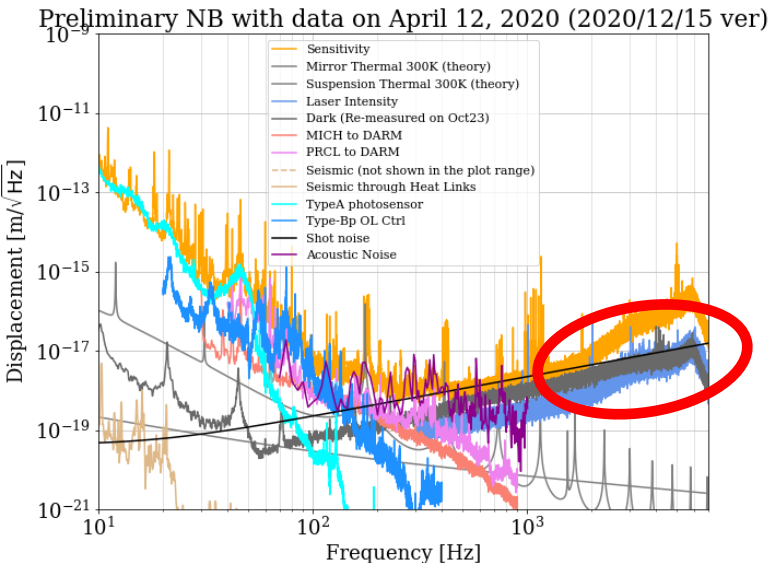

# Laser Noises

- Coupling was larger than expected by 1-2 orders of magnitude (probably due to birefringence)
- **Better interferometer alignment** would reduce the coupling (with WFS)

[JGW-T2011662](#)

## Intensity noise coupling

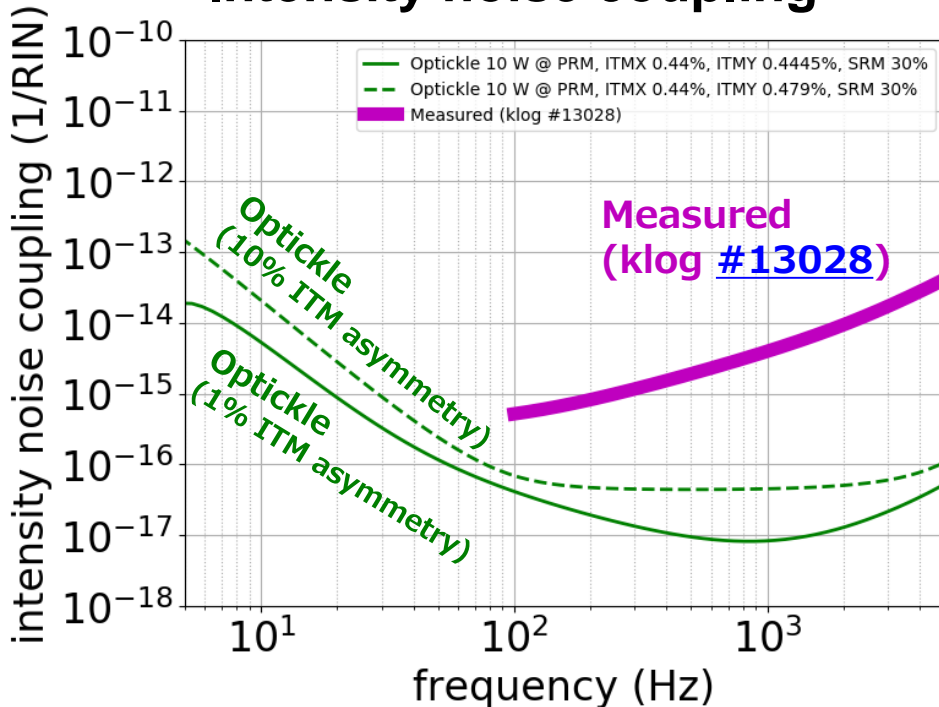

## Frequency noise coupling

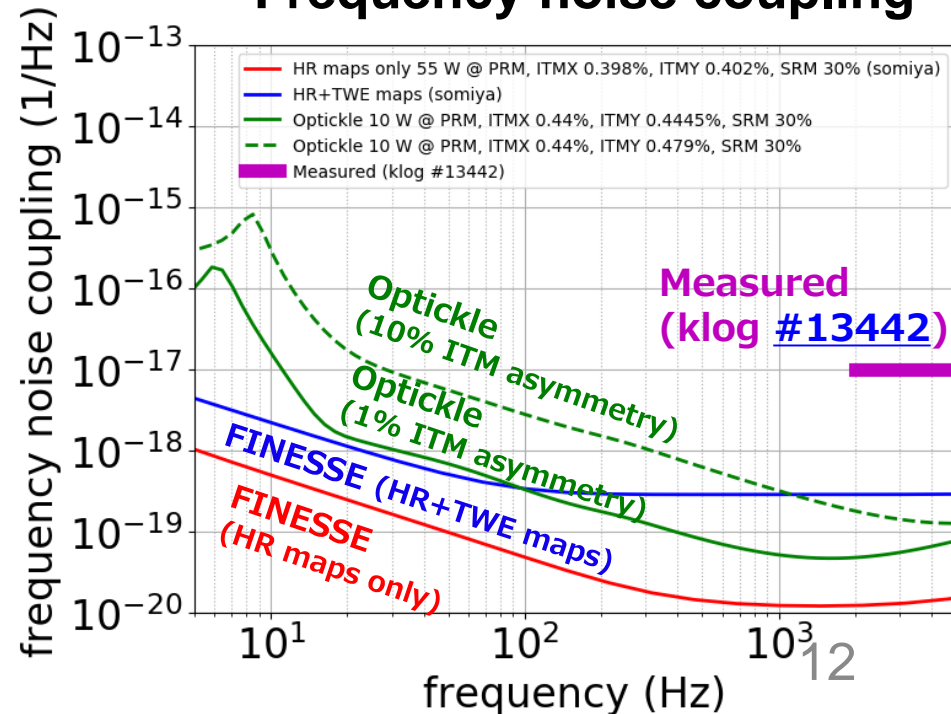

# Laser Frequency noise

- Almost shot noise limited ( $\sim 10$  mW at PD) at 100 Hz
- Not very critical for BNS range

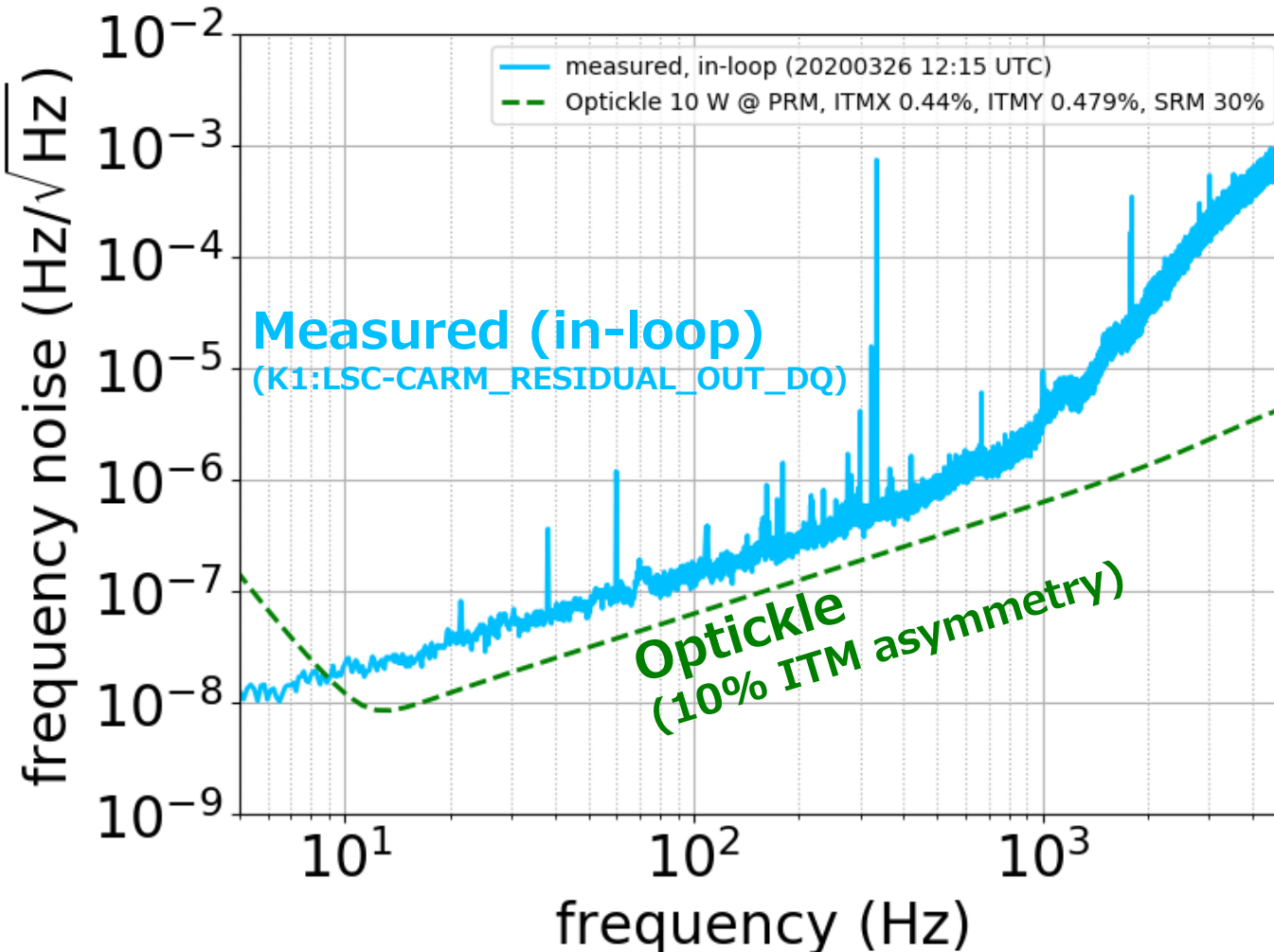

# Laser Intensity noise

- A factor of  $\sim 3$  to shot noise limit
- Some noise from beam jitter ?
- There is a plan to increase power and to reduce beam jitter ([JGW-G2012322](#))

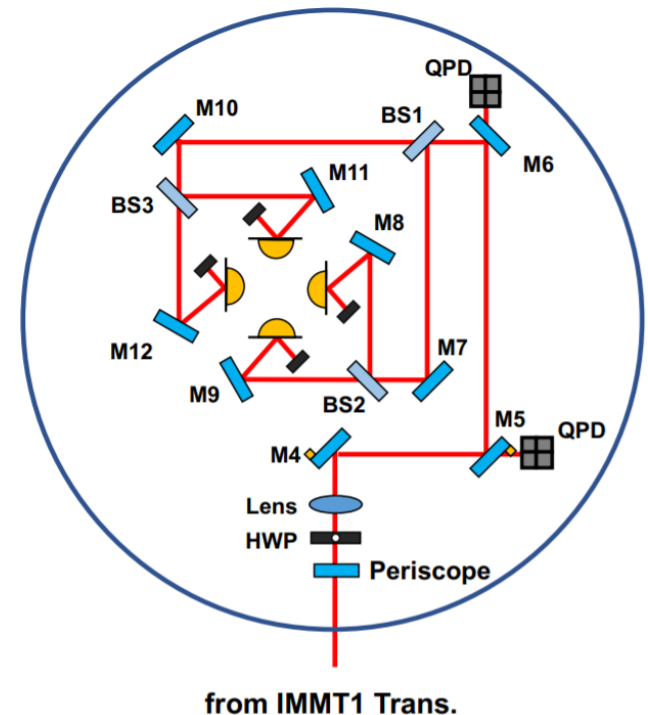
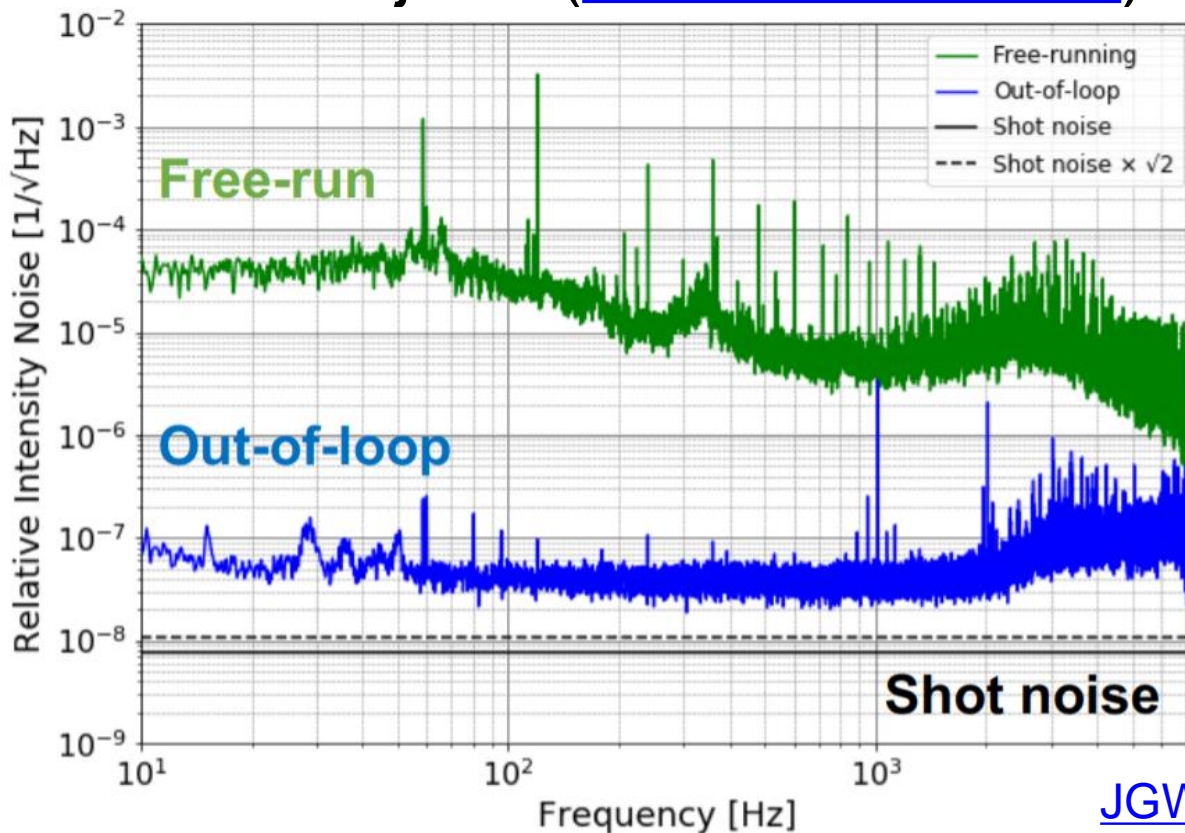

# Expectations for O4

- Laser noises (frequency noise and intensity noise)
- **Shot noise**
- Acoustic noise
- Coupling from auxiliary degrees of freedom
- Thermal noise
- Test mass suspension damping noise

Preliminary NB with data on April 12, 2020 (2020/12/15 ver)

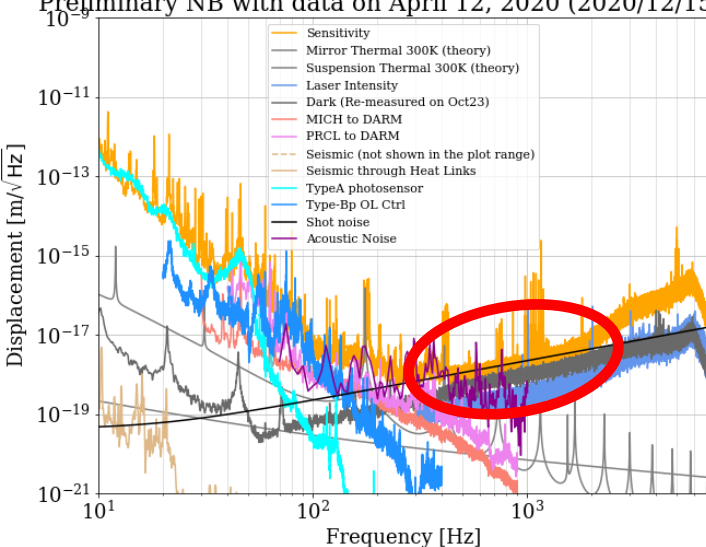

# Shot Noise

- Shot noise in O3 was not good due to tilted SRM
- When DRFPMI, **at least 30 W at BS** is necessary
- When PRFPMI, at least 300 W as BS is necessary
- **DR seems to be almost necessary for O4**  
Suspensions needs to be settled down ([JGW-G2012213](#))

[JGW-T2011662](#)

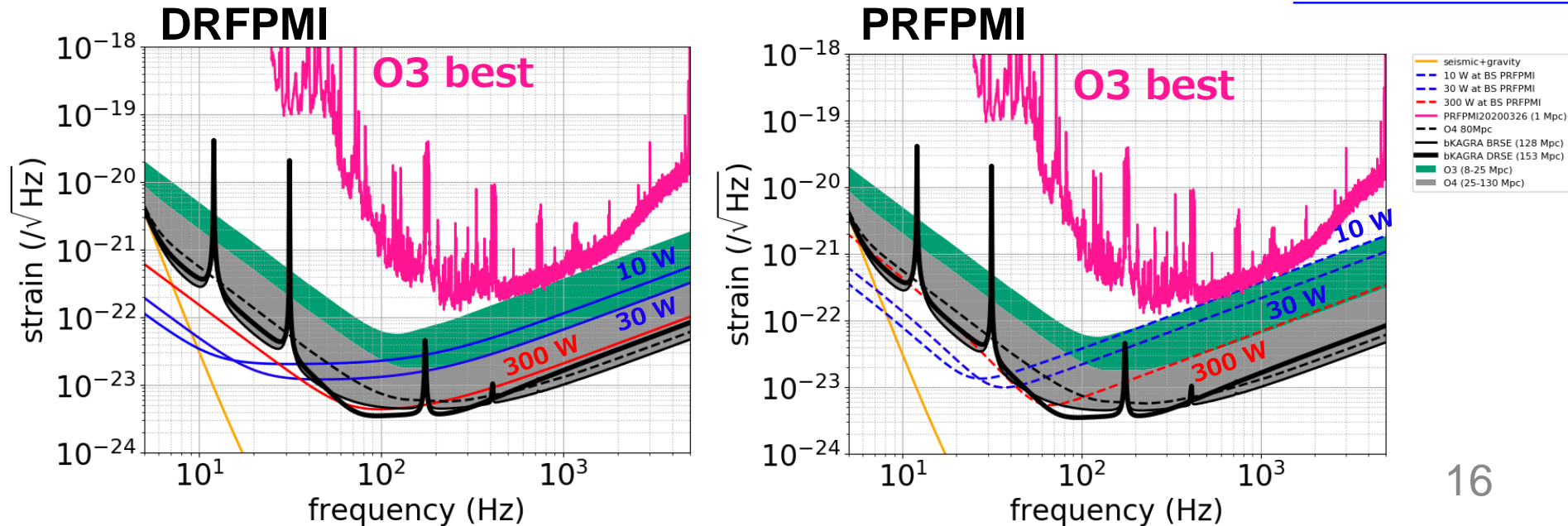



# Expectations for O4

- Laser noises (frequency noise and intensity noise)
- Shot noise
- **Acoustic noise**
- Coupling from auxiliary degrees of freedom
- Thermal noise
- Test mass suspension damping noise

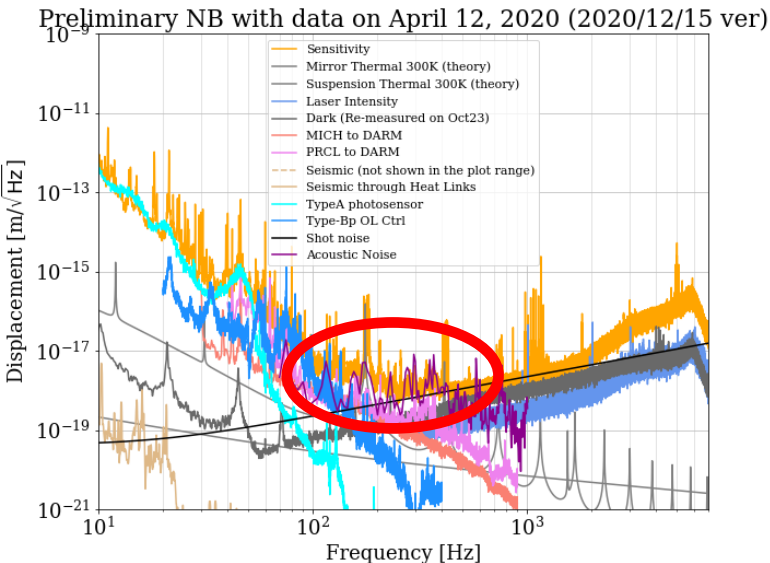

# Acoustic Noise

- Most contribution from bellows between IMC-IFI chamber
- Could be reduced by scattered light mitigation

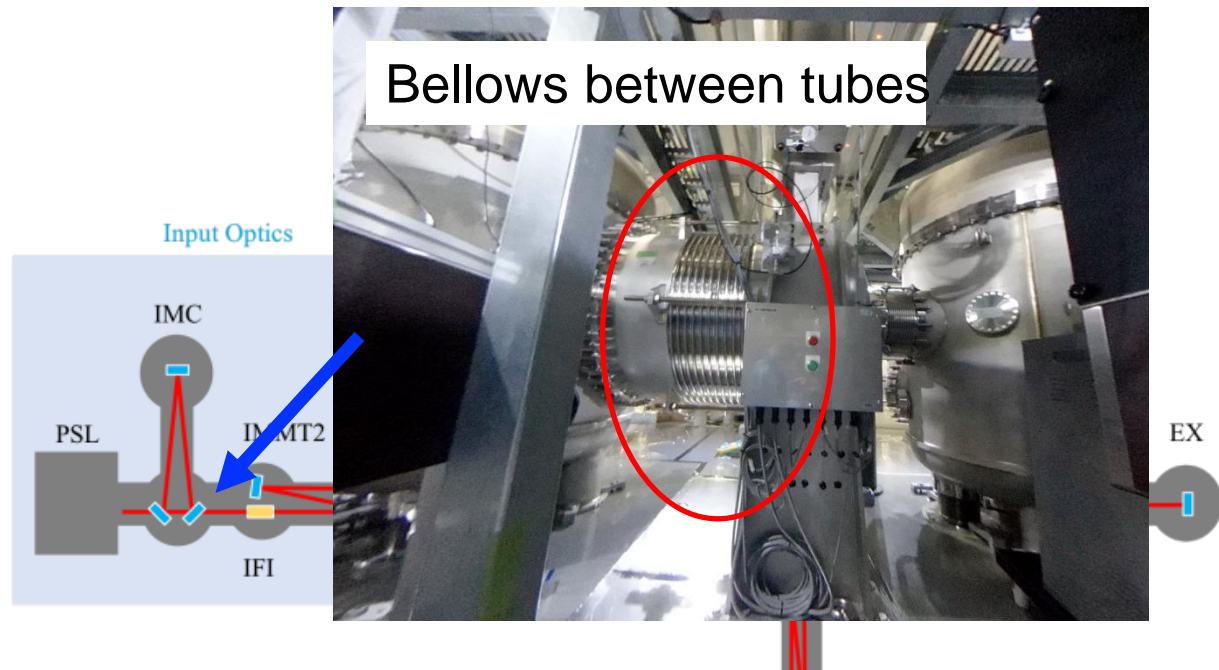

[JGW-G2012315](#)

# Expectations for O4

- Laser noises (frequency noise and intensity noise)
- Shot noise
- Acoustic noise
- **Coupling from auxiliary degrees of freedom**
- Thermal noise
- Test mass suspension damping noise

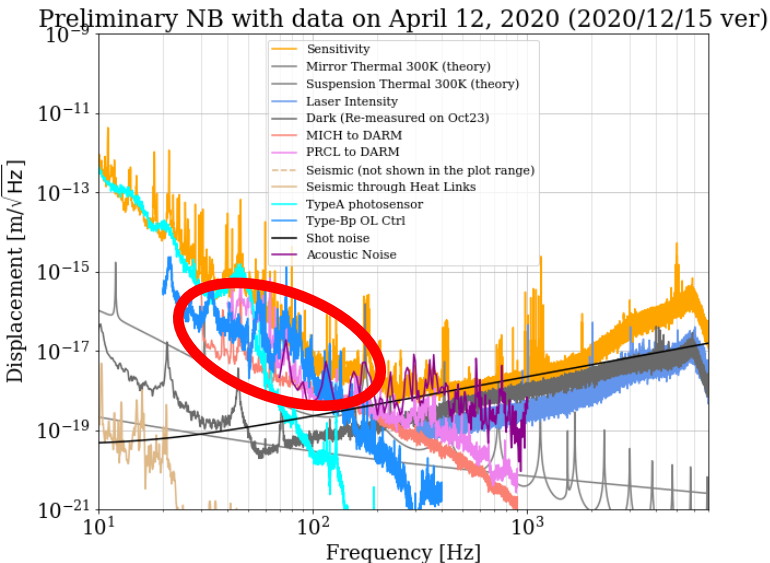

# Coupling from Auxiliary DOFs

- Coupling MICH (Michelson) and PRCL (power recycling cavity length)
- Feedforward reduces the coupling by  $\sim 1/10$  at max
- **More feedforward gain** necessary
- Also, **better diagonalization** of sensing matrix can be done for O4

[JGW-G2012315](#)

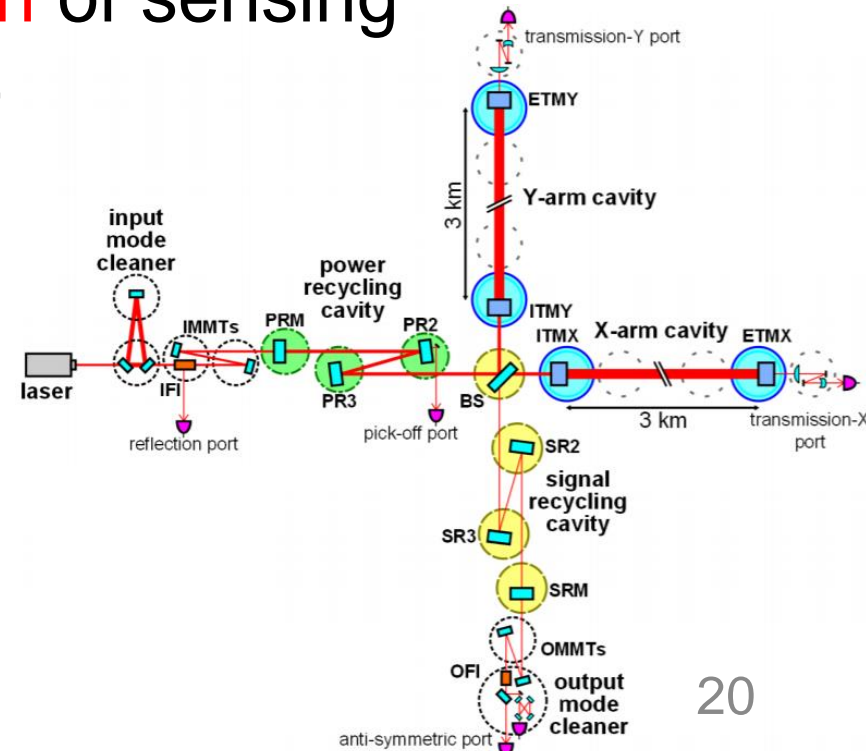
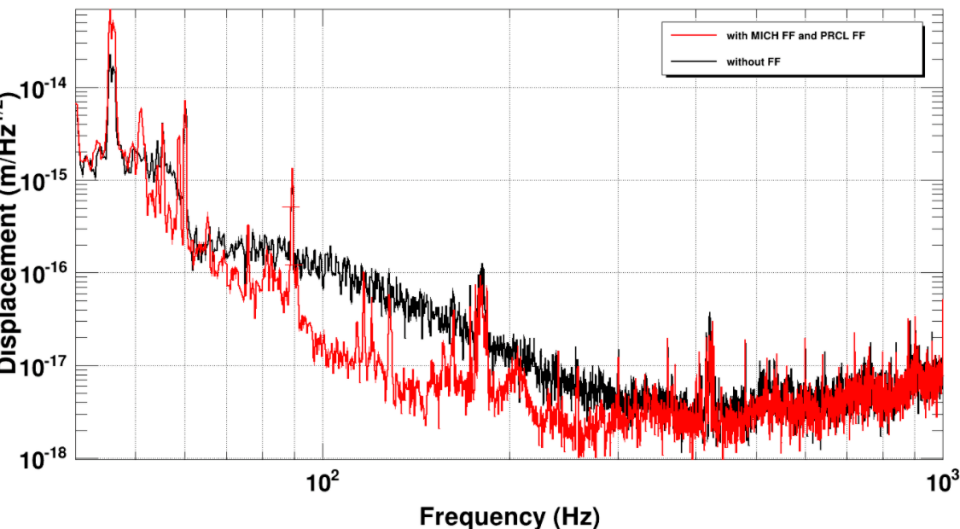

# Expectations for O4

- Laser noises (frequency noise and intensity noise)
- Shot noise
- Acoustic noise
- Coupling from auxiliary degrees of freedom
- **Thermal noise**
- Test mass suspension damping noise

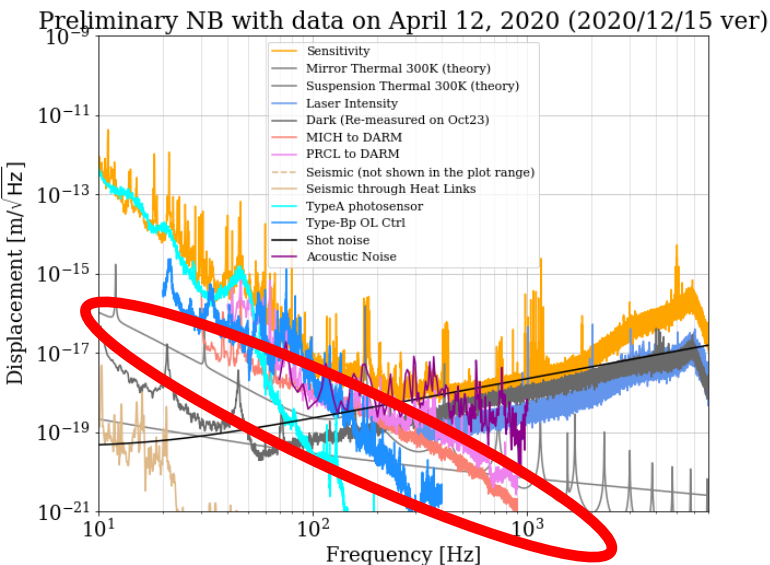

# Thermal Noise

- At least **below ~100 K** is necessary

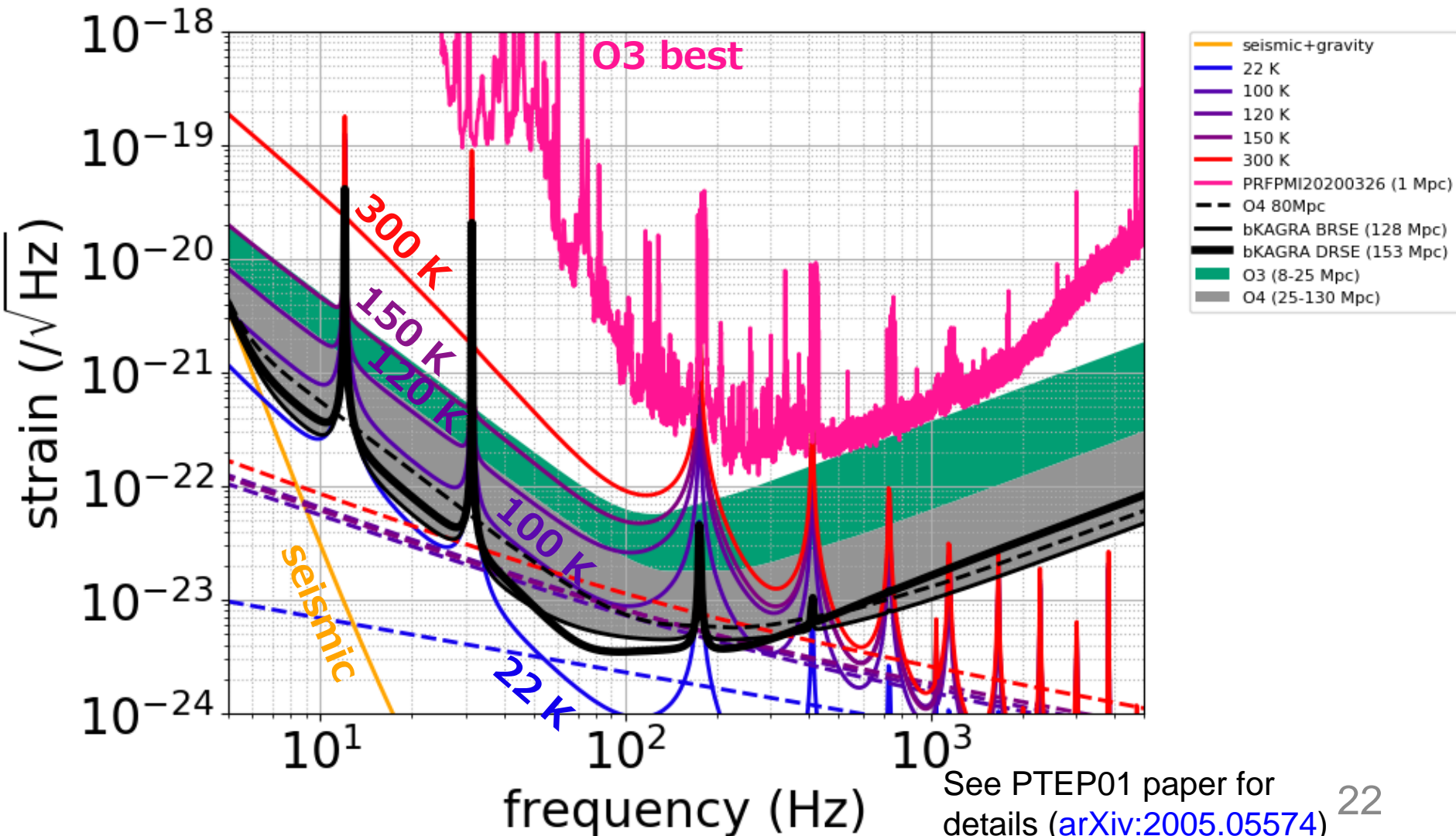

# Expectations for O4

- Laser noises (frequency noise and intensity noise)
- Shot noise
- Acoustic noise
- Coupling from auxiliary degrees of freedom
- Thermal noise
- **Test mass suspension damping noise**

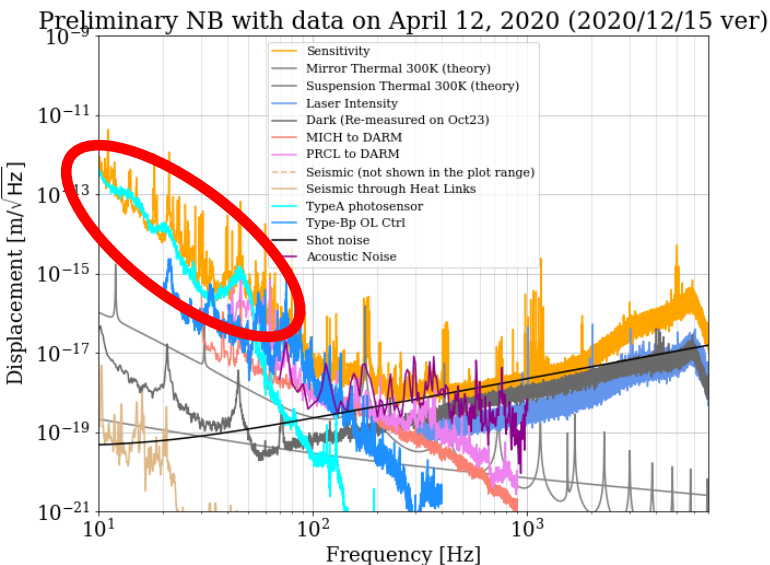

# Test Mass Suspension Damping

- Noises from marionette damping using photo sensors are limiting
- Plan to install optical levers also for marionette and platform stages  
However, whether if we can completely turn off photo sensor damping is not clear since there might be some modes which can be only seen by photo sensors
- Suspension Commissioning Team

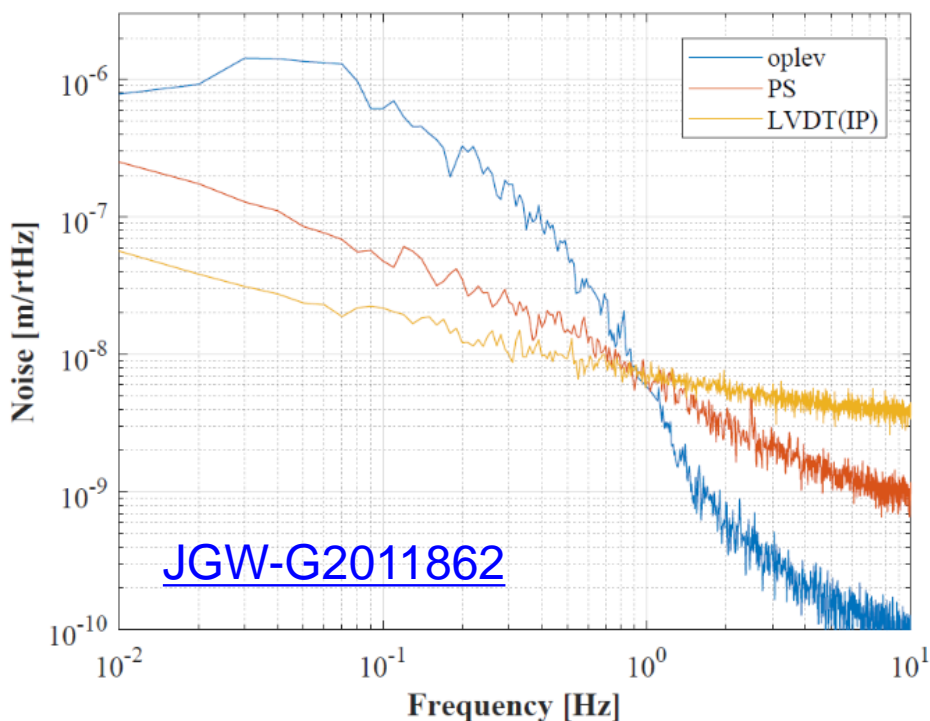

↓ ~1/10  
at 10 Hz

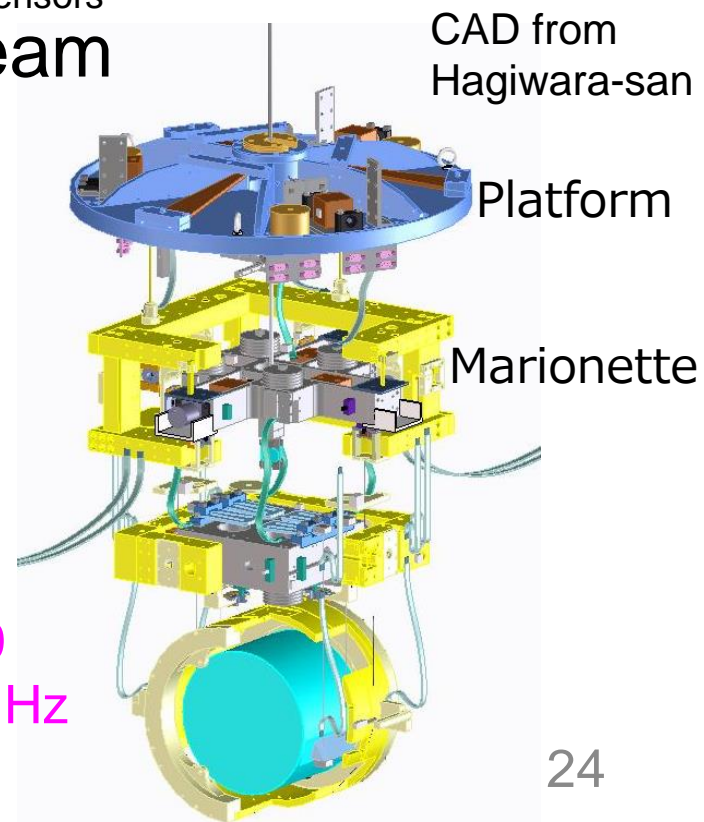



# Actuator Noise

- Noises from high power coil driver used for O3 is not good for O4
- **Coil driver switch** to turn off high power coil driver after the lock acquisition necessary

[JGW-T1910142](#)

## Nominal Case

Actuator noise NoiseBudget

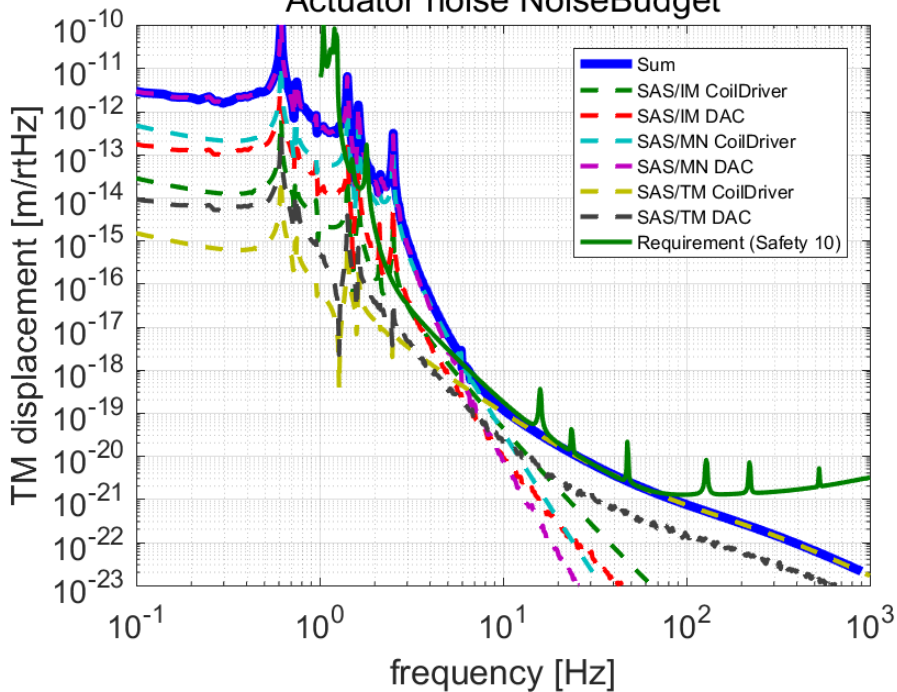

## High Power TM Case

Actuator noise NoiseBudget

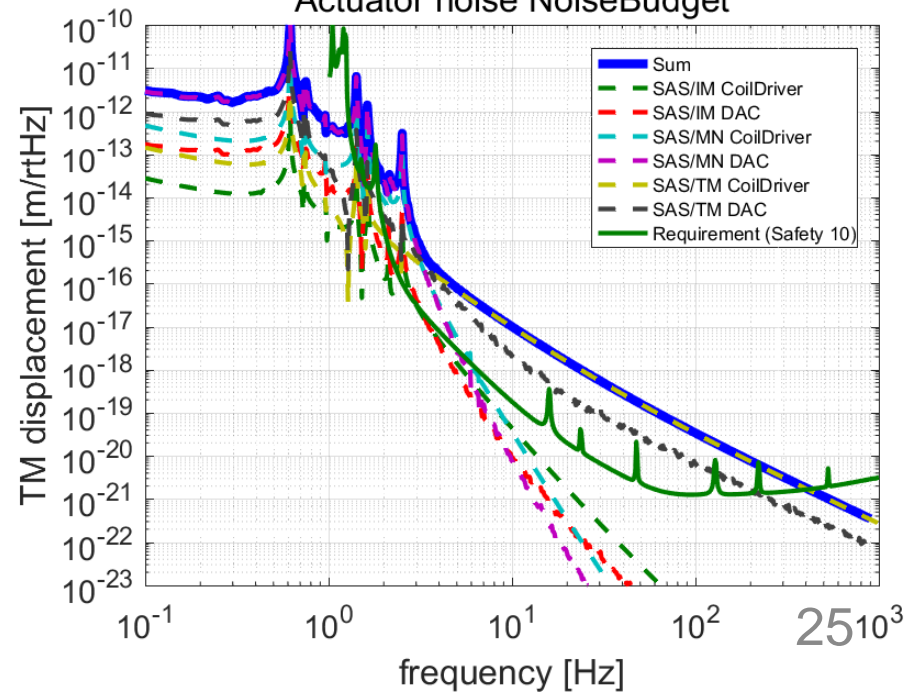

# Summary

- O4 sensitivity would be **~70 Mpc at most optimistic case**
- Laser noises
  - alignment improvement (with **WFS**) necessary 😐
  - improvement plan for ISS seems promising 😊
- Shot noise
  - **DRFPMI** with more than 30 W at BS necessary 😐
- Thermal noise
  - at least ~100 K necessary 😊
- Coupling of auxiliary degrees of freedom
  - more sensing matrix diagonalization necessary 😊
  - more feedforward gain necessary (by ~ x10) 😡
- Suspension damping noises
  - coil driver switch necessary
  - **concrete planning based on noise estimates necessary** 😱

# Details

# O4 Considerations

- Temperature ?
  - **At least below 100 K** required to achieve 25 Mpc ([JGW-T2011662](#))
  - ~40 K seems to be optimum considering the balance between the absorption from the input power and thermal noise ([JGW-G2011756](#))
  - Mirror frosting observed below ~30 K ([arXiv:2005.05574](#))
- PRFPMI or DRFPMI ?
  - lock of DRFPMI not achieved yet, but close ([JGW-G2012213](#))
- Input power ?
  - not very critical at this stage ([JGW-T2011662](#))
  - **300 W at BS feasible** from laser preparations and TM cooling
- Laser frequency and intensity noise ?
  - coupling **larger than expected** due to ITM inhomogeneity ([JGW-T2011662](#))
- Unknown excess noise ?
  - At least a **reduction by a factor of 50** necessary to achieve 25 Mpc ([JGW-T2011662](#))

# Various Thermal Noise

- All temperatures

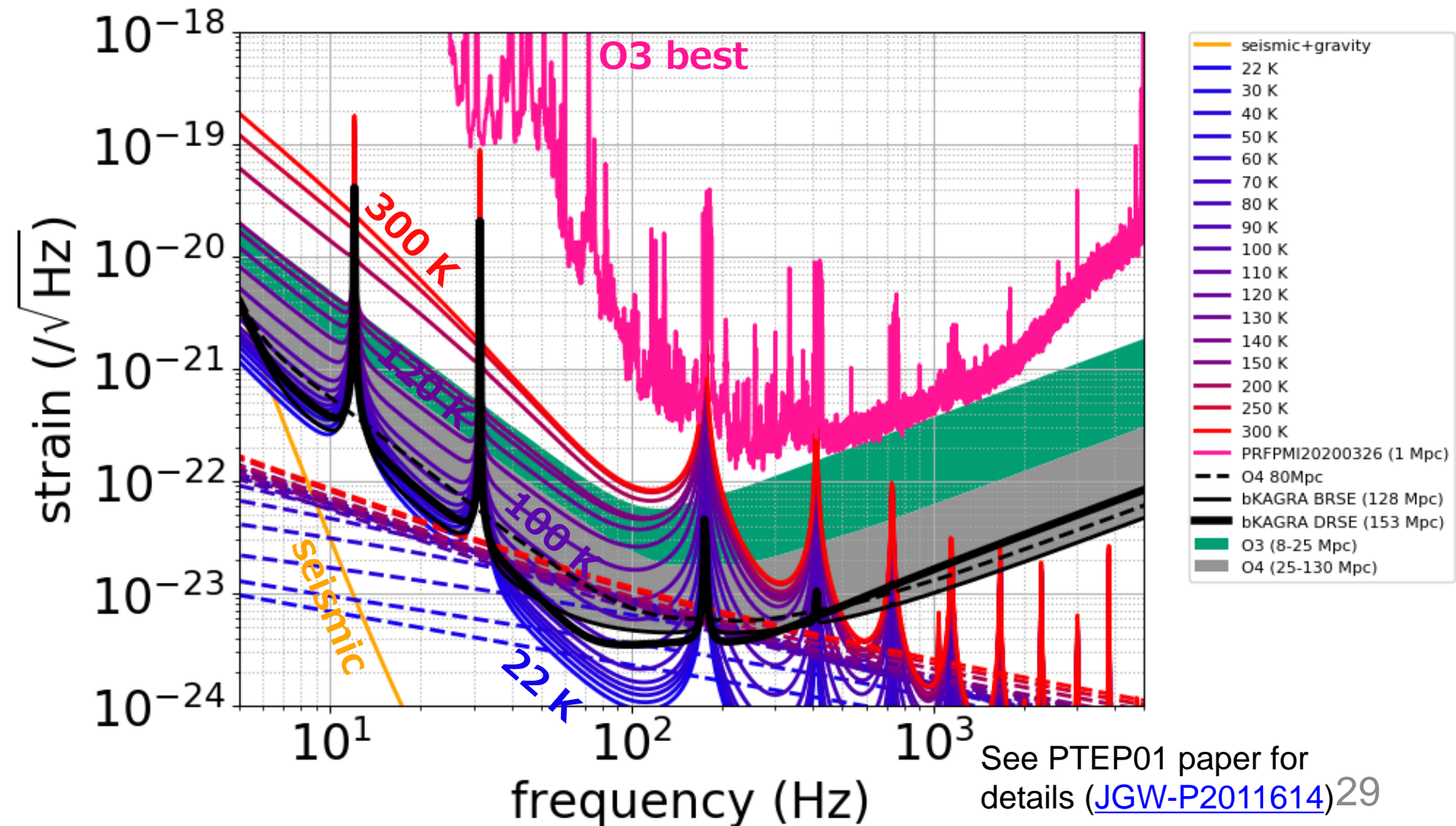

# Various Quantum Noise (DR)

- All powers

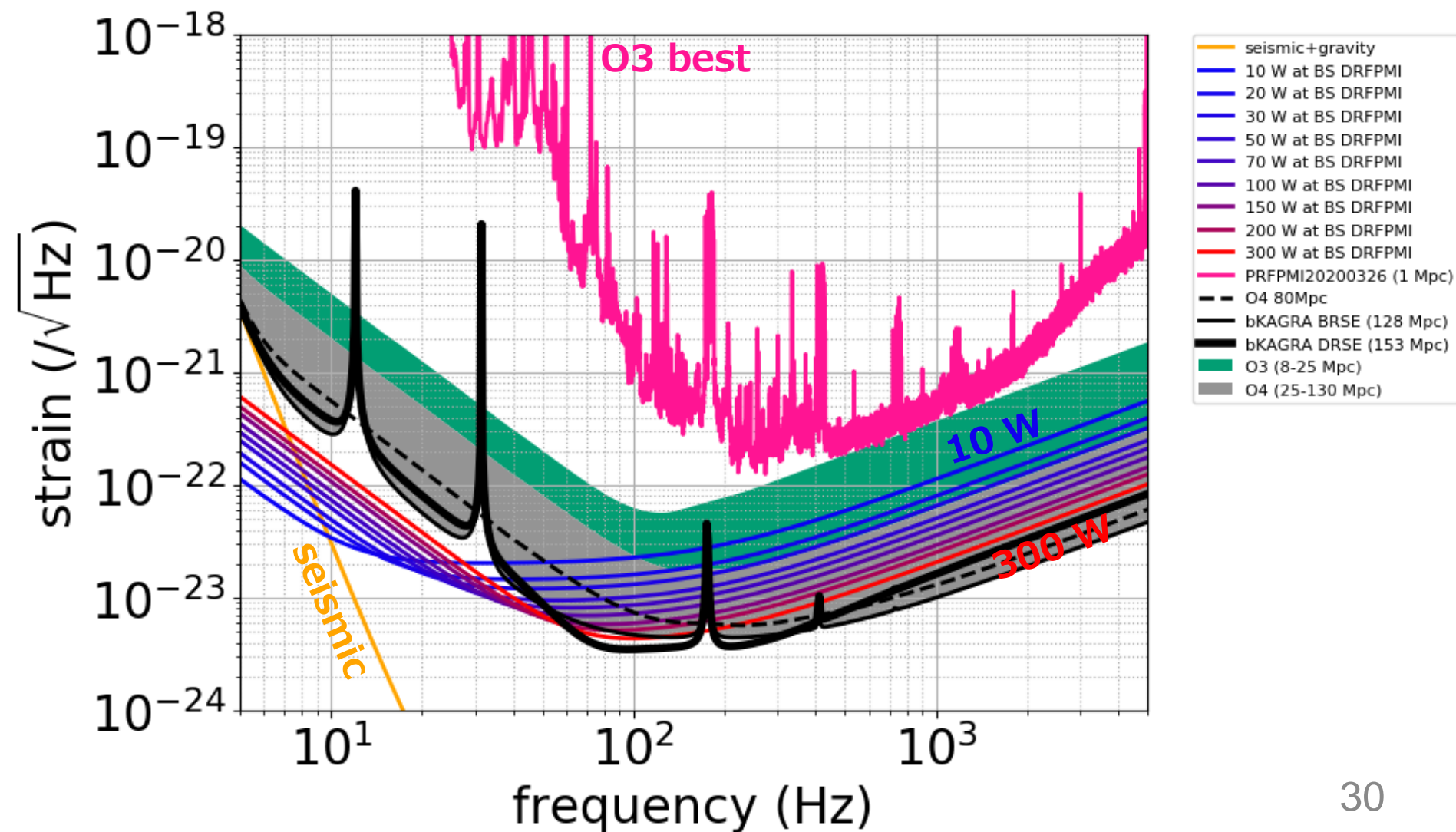

# Various Quantum Noise (PR)

- All powers

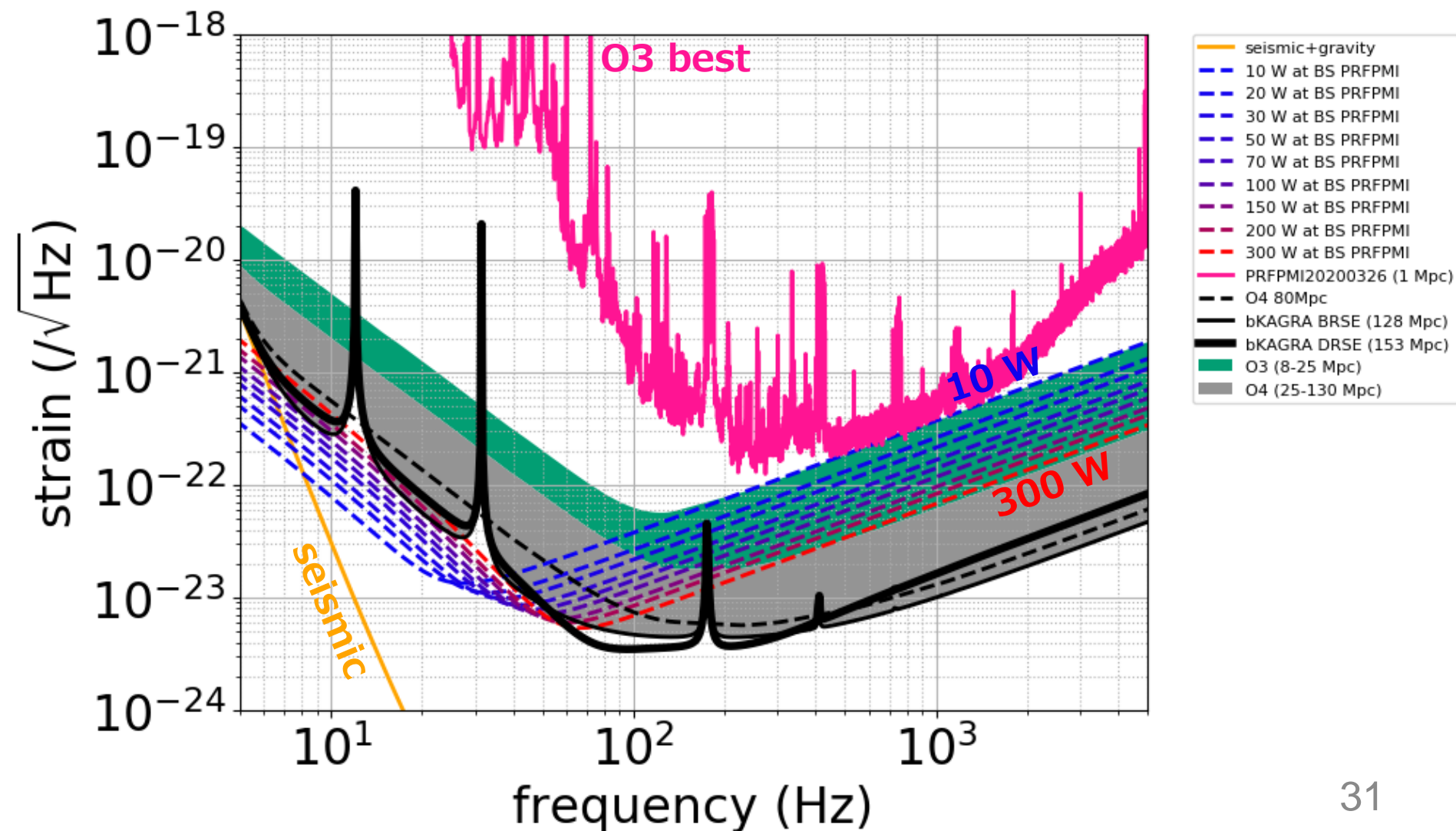

# How to Realize 100 K ?

- **Possible cooling process?**

- First cool the test mass with four cryocooler
- When reached below  $\sim 100$  K, turn off two cryocoolers for cryopayload (shields have to be kept cooled); as we have done in July 2019, we can keep the temperature at  $\sim 100$  K (klog [#10033](#))
- Turn on two cryocoolers occasionally to keep the temperature  $\sim 100$  K

- **Maximum input power?**

- Thermal lensing: At 100 K, thermal lensing is smaller by  $1/100 \sim 1/300$  than 300 K, but larger by 4 orders of magnitude than 20 K. Thermal lensing would be OK below  $\sim 130$  K (See [JPCS 32, 062 \(2006\)](#)).
- Cooling power (with 4 cryocoolers): 67 K can be achievable with 0.8 W heat load to the test mass, with current thermal resistance of 70 K/W (according to [JGW-G1910569](#)).  $< 300$  W at BS would be OK.
- Cooling power (with 2 cryocoolers): According to the cooling curve from bKAGRA Phase 1 (7 K/day at around 100 K), 0.2 W heat load makes the mirror temperature at steady state (around 100 K, thermal conductivity of sapphire fibers are low). Absorption from light will be  $\sim 0.001 \cdot P_{BS}$  where  $P_{BS}$  is the power at BS. Therefore,  $P_{BS} = 200$  W is good to keep  $\sim 100$  K.



# Frosting of the Test Mass

- Finesse drop observed when one of the test mass temperature is below  $\sim 30$  K

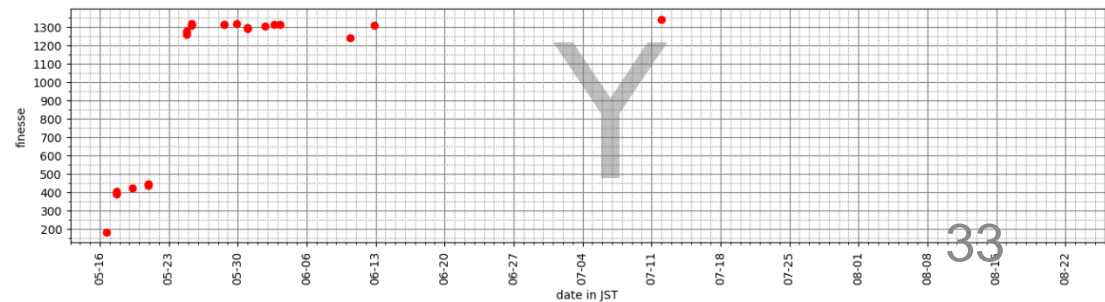
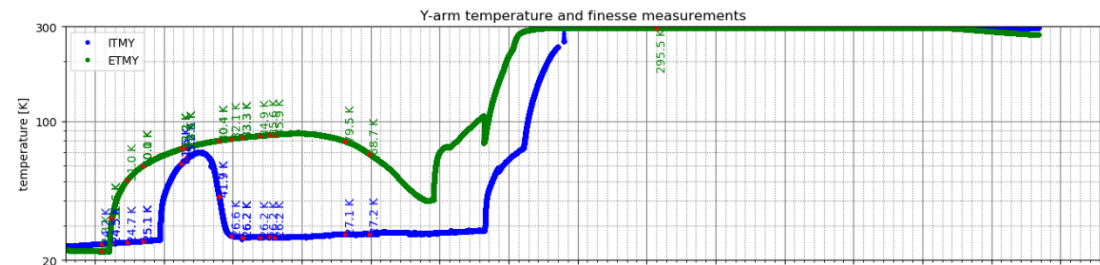
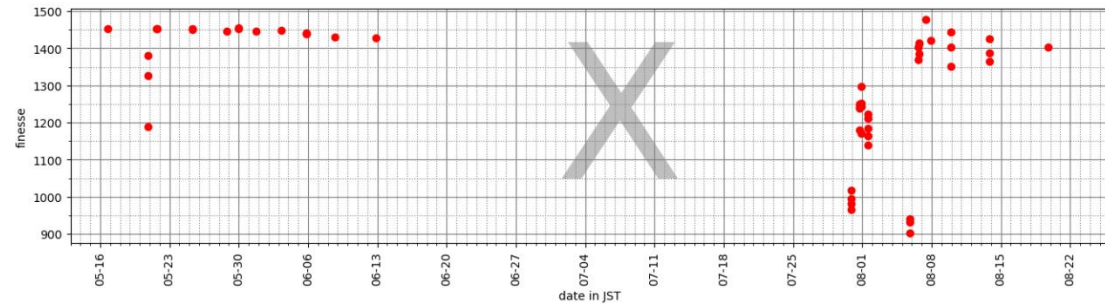
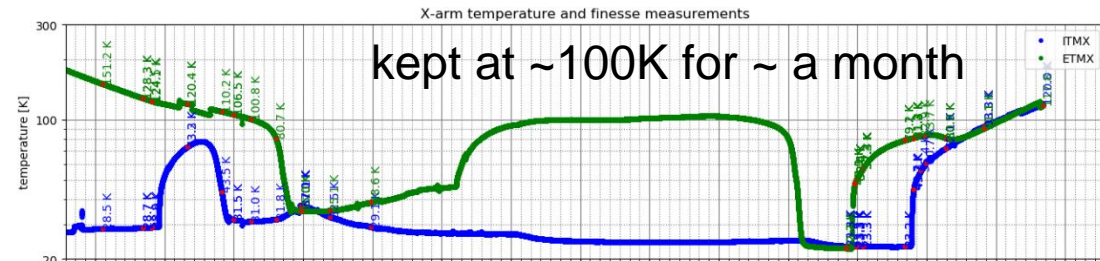

klog [#10033](#)