

かぐらトンネル

Ph. D. defense
博士論文審査会

A Study of Baseline Compensation System for Stable Operation of Gravitational-wave Telescopes

(重力波望遠鏡の安定稼働のための
基線長補償システムの研究)

Kouseki Miyo
三代 浩世希

January 15th, 2020

JGW-G2011167-v11

Contents

“A Study of **Baseline Compensation System** for **Stable Operation** of Gravitational-wave Telescopes”

1. Introduction

- Gravitational-wave (GW) and GW detector
- Problematic seismic motion for stable operation

2. Geophysics Interferometer

- Overview
- Comparison with seismometer

3. Baseline Compensation System

- Concept
- Control design

4. Demonstration and Results

- Setup for demonstration
- Result and discussion

5. Summary

- Conclusion
- Future prospects

Contents

1. Introduction

- Gravitational-wave (GW) and GW detector
- Problematic seismic motion for stable operation

2. Geophysics Interferometer

- Overview
- Comparison with seismometer

3. Baseline Compensation System

- Concept
- Control design

4. Demonstration and Results

- Setup for demonstration
- Result

5. Summary

- Conclusion
- Future prospects

Gravitational-wave (GW)

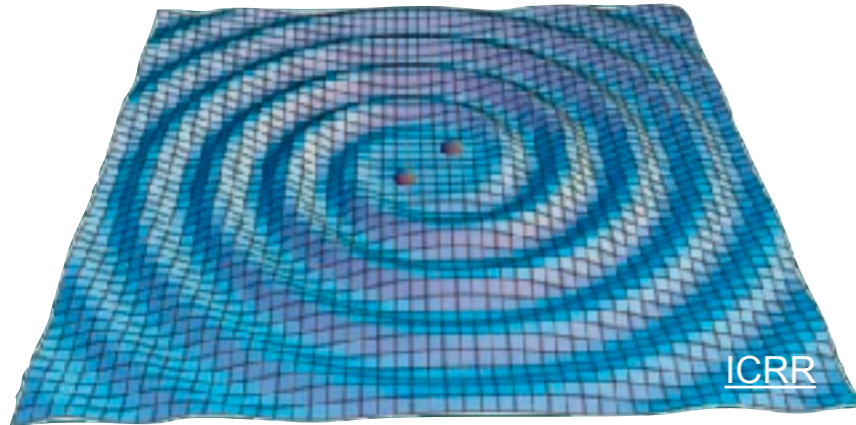

GW

- Ripple of space-time
- compact and massive objects generate

GW sources

- Binary black hole (BBH) merger
- Binary neutron star (BNS) merger
- Supernovae explosion

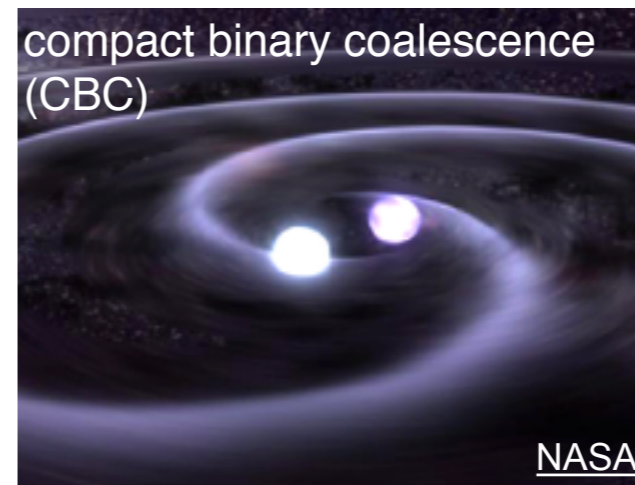

Fruitful informations for physics

- Testing the general relativity
- Nuclear equation of state
- A new observation tool

GW observations bring new informations of the universe to us.

GW Detector

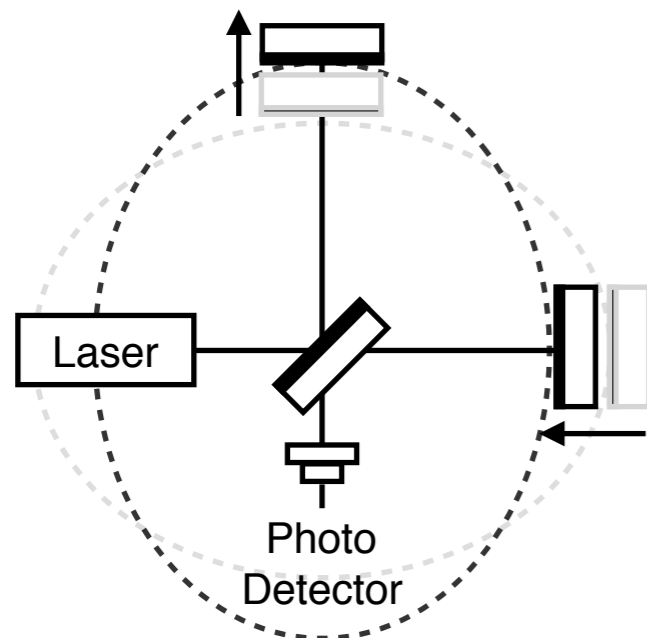

Michelson interferometer

GW

- Tidal deformation
- Two polarizations

Michelson interferometer

- Differential arm length changes
- Wide antenna pattern

GW propagation

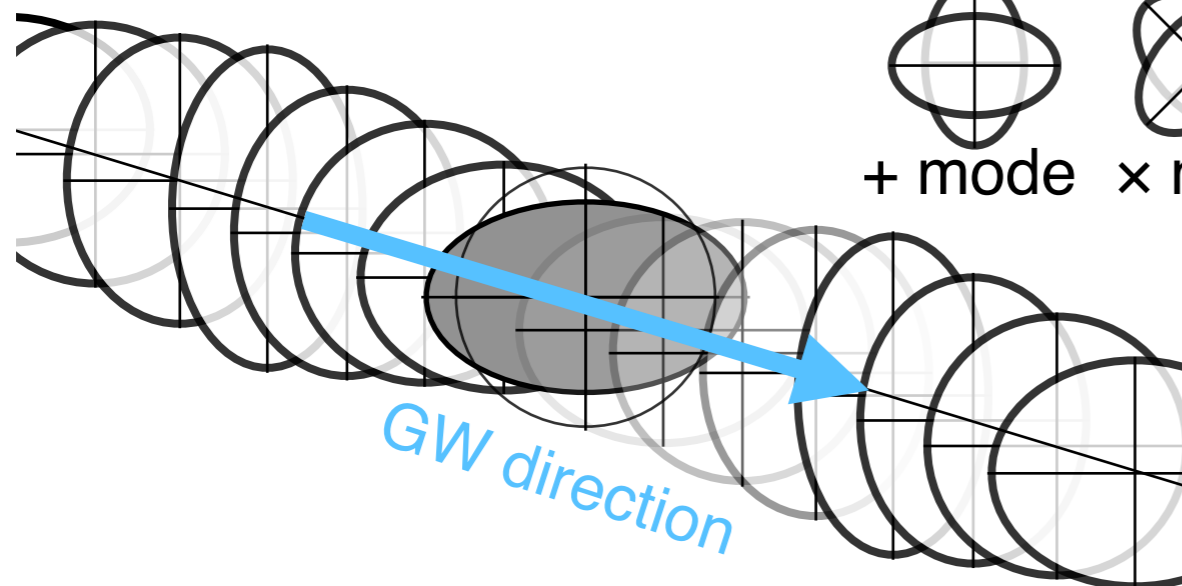

Polarizations

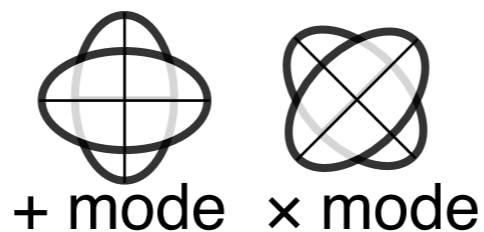

Antenna patterns

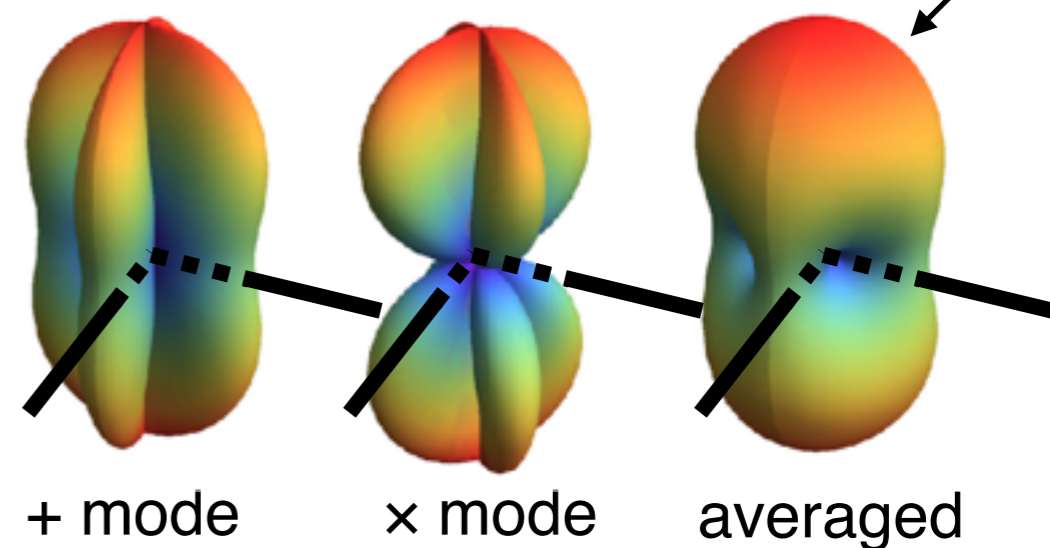

We need **multiple detectors** to determine **direction and polarizations**.

GW Detectors



Network Duty Cycle

$$\cong D_1 \times D_2 \times D_3 \times D_4$$

(D_i : duty cycle of the i -th detector)

Determination by multiple detectors

- 3 detectors for direction
- 4 detectors for polarization

Network duty cycle is below 50 %

- Lost the direction
- Lost the polarization
- Lost rare “Near-Earth” events



Duty cycle is crucial

Seismic Noise Limits the Duty Cycle

Problematic seismic motions (< 1 Hz)

- **Microseismic motions** (0.1 - 1 Hz)
 - Ocean wave
 - Depends on weather
- **Large earthquakes** (0.03 - 0.1 Hz)
 - Not frequent (1/month)
 - Continue 2-3 hours
- **Earth tides** (1/2 day)
 - RMS amp. ~ 100 μm
 - Excess actuator range

e.g. KAGRA

e.g. LIGO

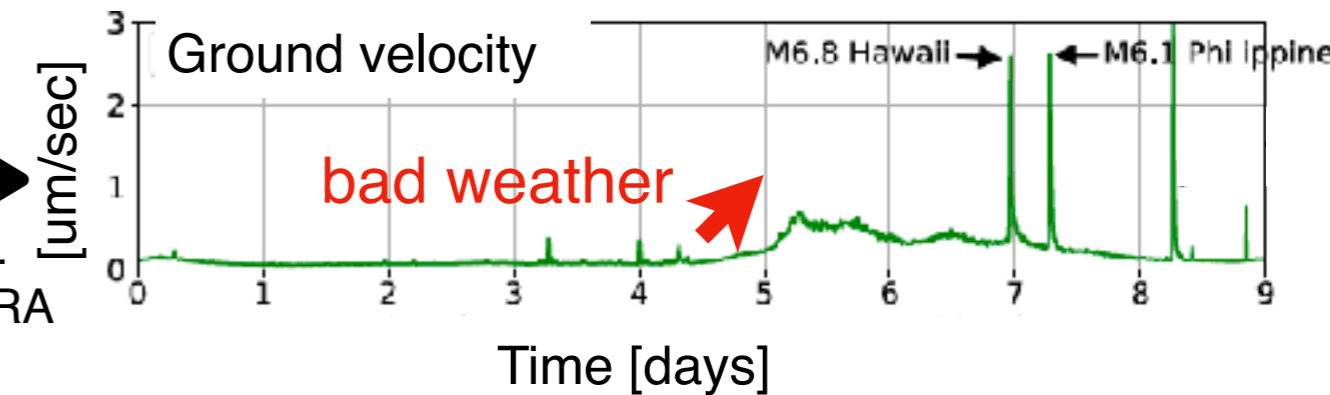
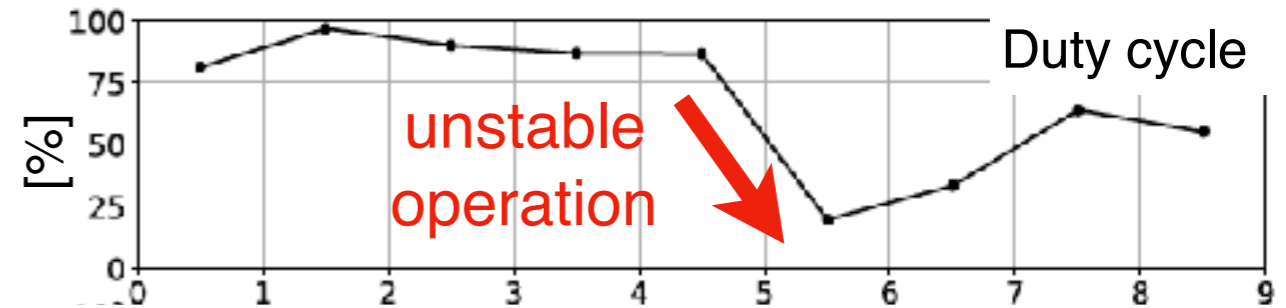

T Akutsu et al. Class. Quantum Grav. 36 (2019) 165008

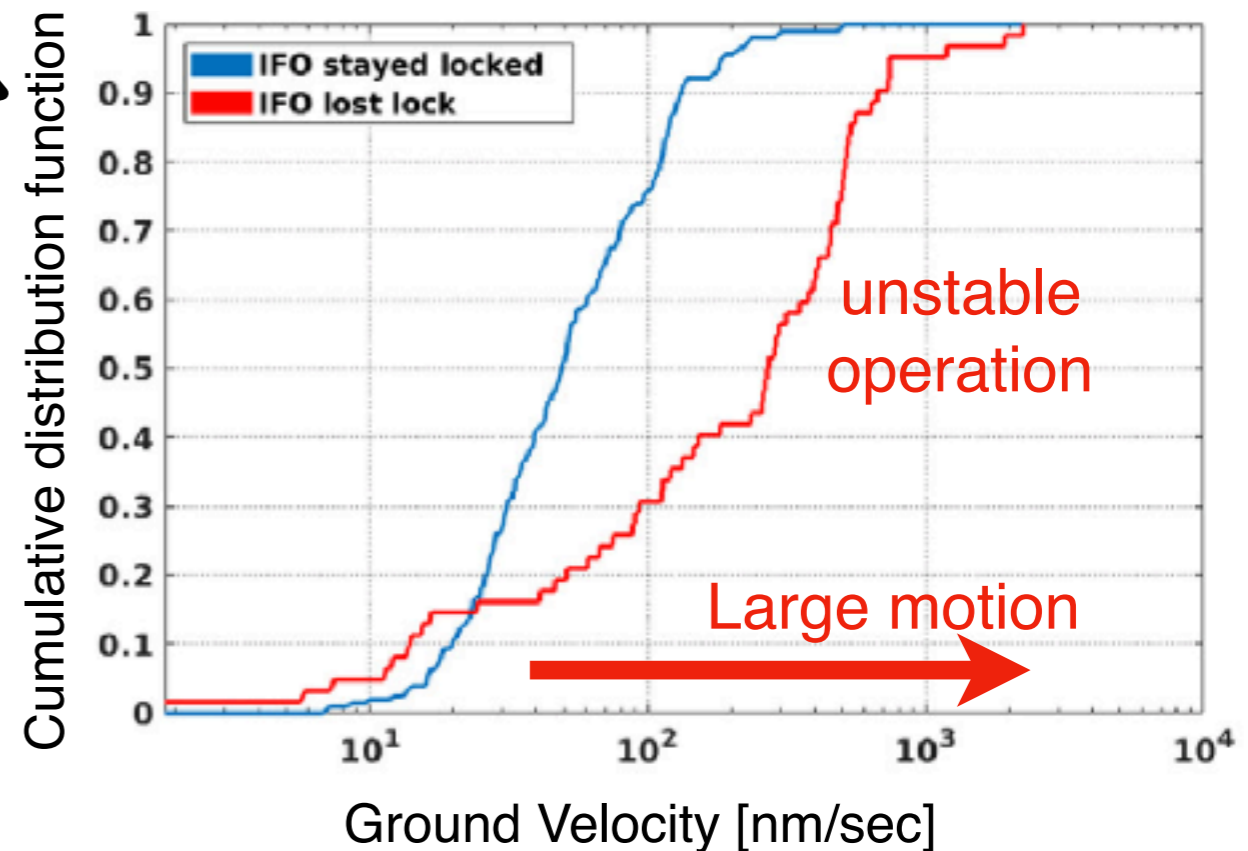

S Biscans et al. Class. Quantum Grav. 35 (2018) 055004

All GW detectors are suffering from the seismic motions < 1 Hz. 7

Difficulties of the GW detector operation



“Dual-recycled Fabry–Pérot Michelson interferometer”

- Three optical resonance cavities
- Must keep on resonance
- Suspended mirrors

Arm cavity is most unstable

- Most sensitive cavity
- Weak TM actuator



“Hierarchical” feedback control

- **large** (low-freq.) → **upper** act.
- **small** (high-freq.) → **lower** act.

→ **Sacrifice a stability of the control**

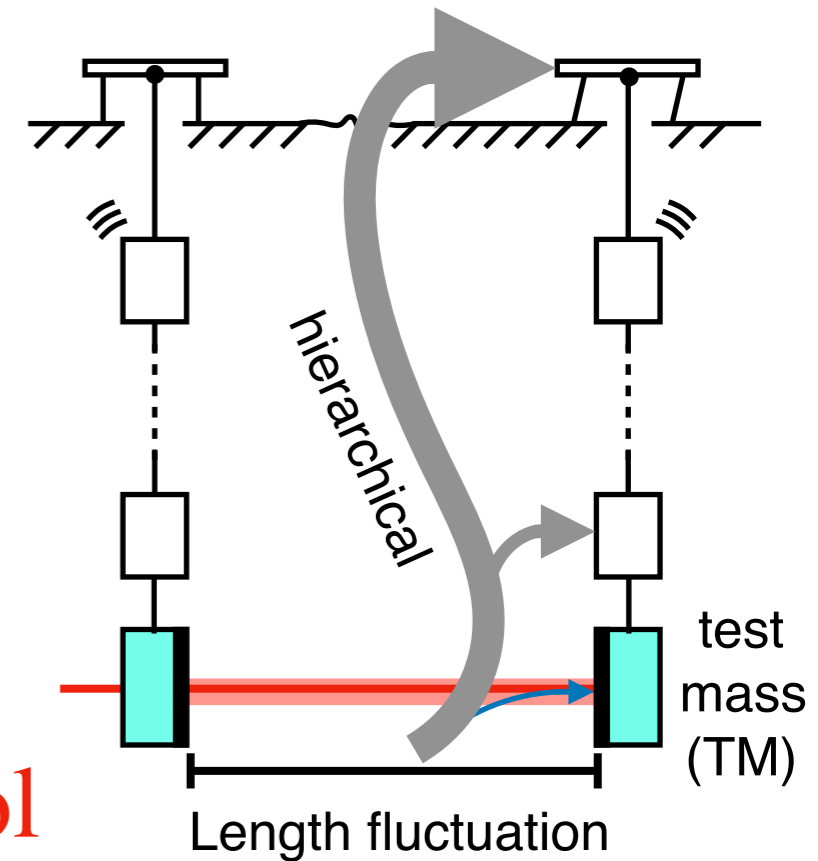

power recycling cavity

Laser

km-scale arm cavity

signal recycling cavity

test mass (TM)

Motivation of low-frequency seismic isolation

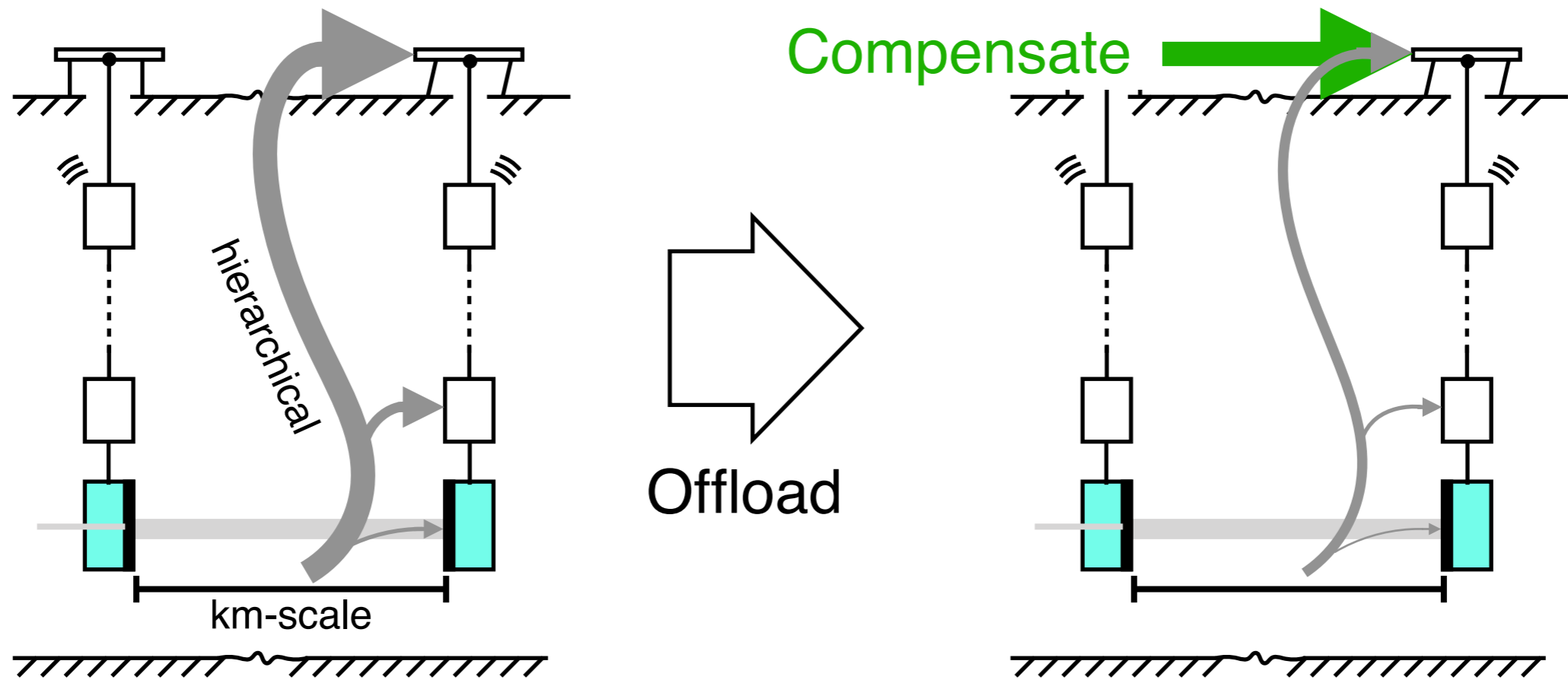

Profits of offloading

- saturation of weak actuators
- stability of control loop

Baseline sensors for the compensation ($< 1\text{ Hz}$)

- Two seismometers : indirect, no sensitivity
- Strainmeter : direct, enough sensitivity

KAGRA has a strainmeter named “**Geophysics Interferometer**”

Contents

1. Introduction

- Gravitational-wave (GW) and GW detector
- Problematic seismic motion for stable operation

2. Geophysics Interferometer

- Overview
- Comparison with seismometer

3. Baseline Compensation System

- Concept
- Control design

4. Demonstration and Results

- Setup for demonstration
- Result

5. Summary

- Conclusion
- Future prospects

KAGRA and Geophysics Interferometer

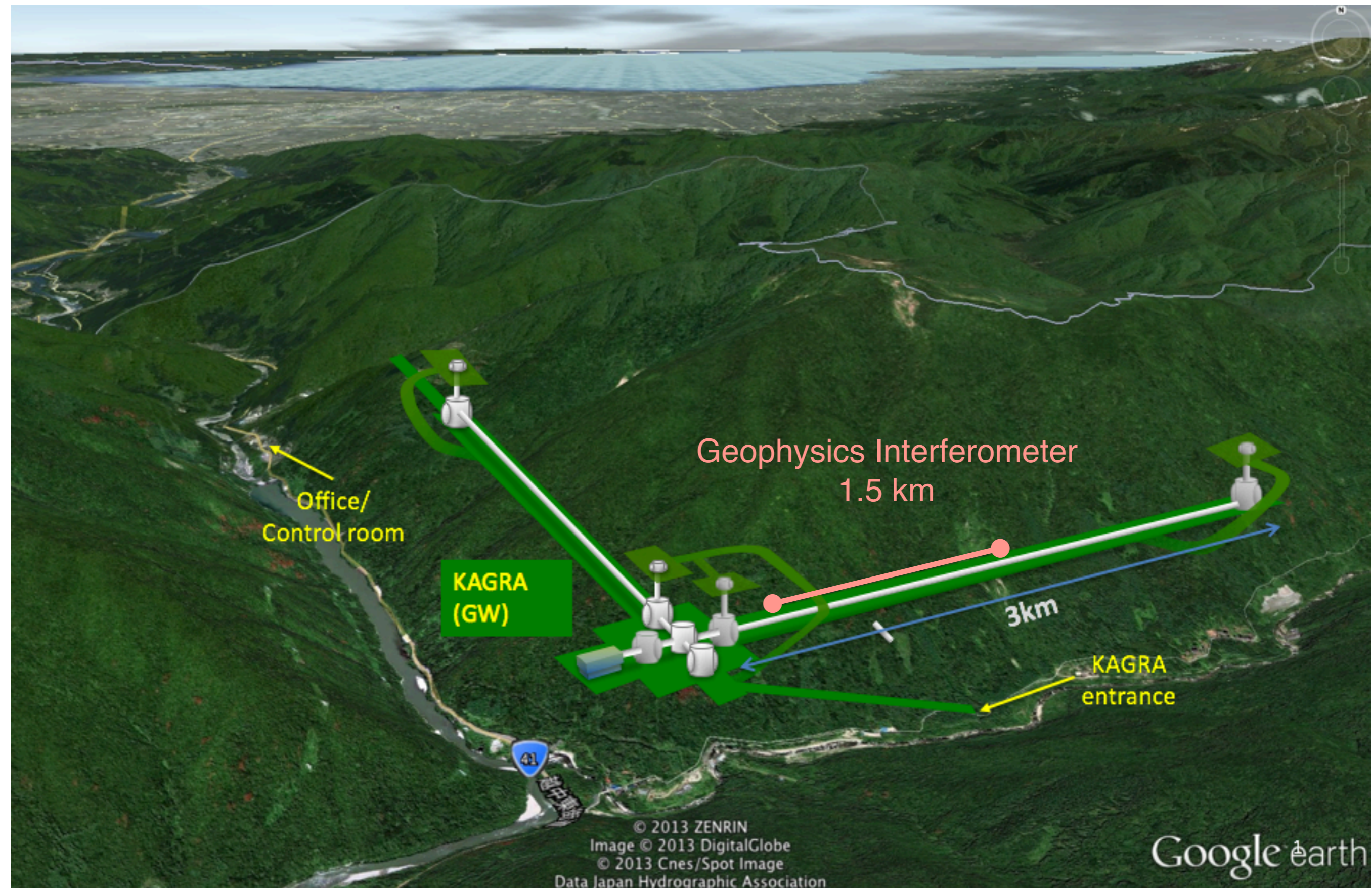

Geophysics Interferometer (GIF)

- A 1500 m strainmeter
- Developed by earthquake researchers.
- Geophysical purpose (earth oscillations, earthquakes, ...)
- Observing from 2016.

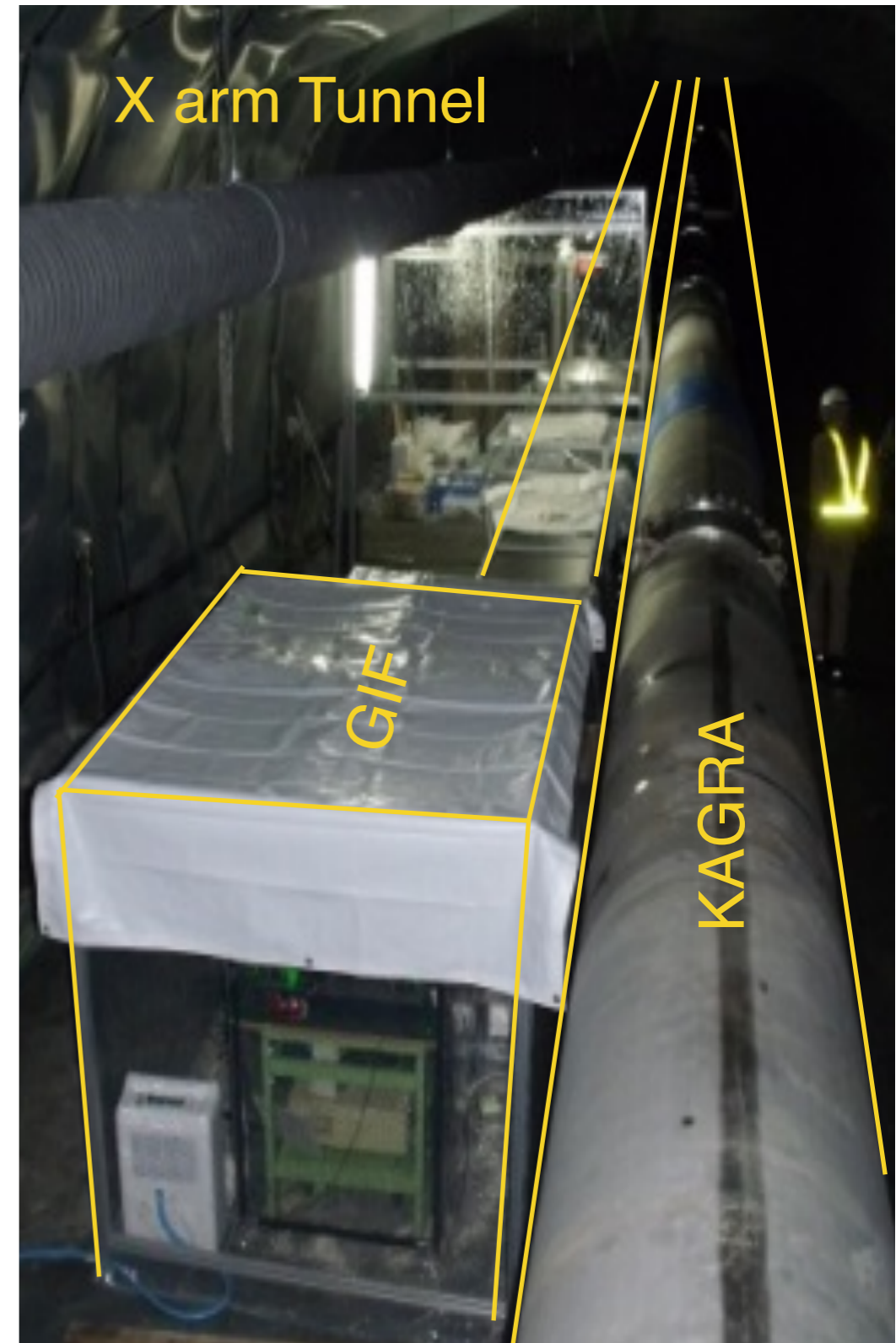
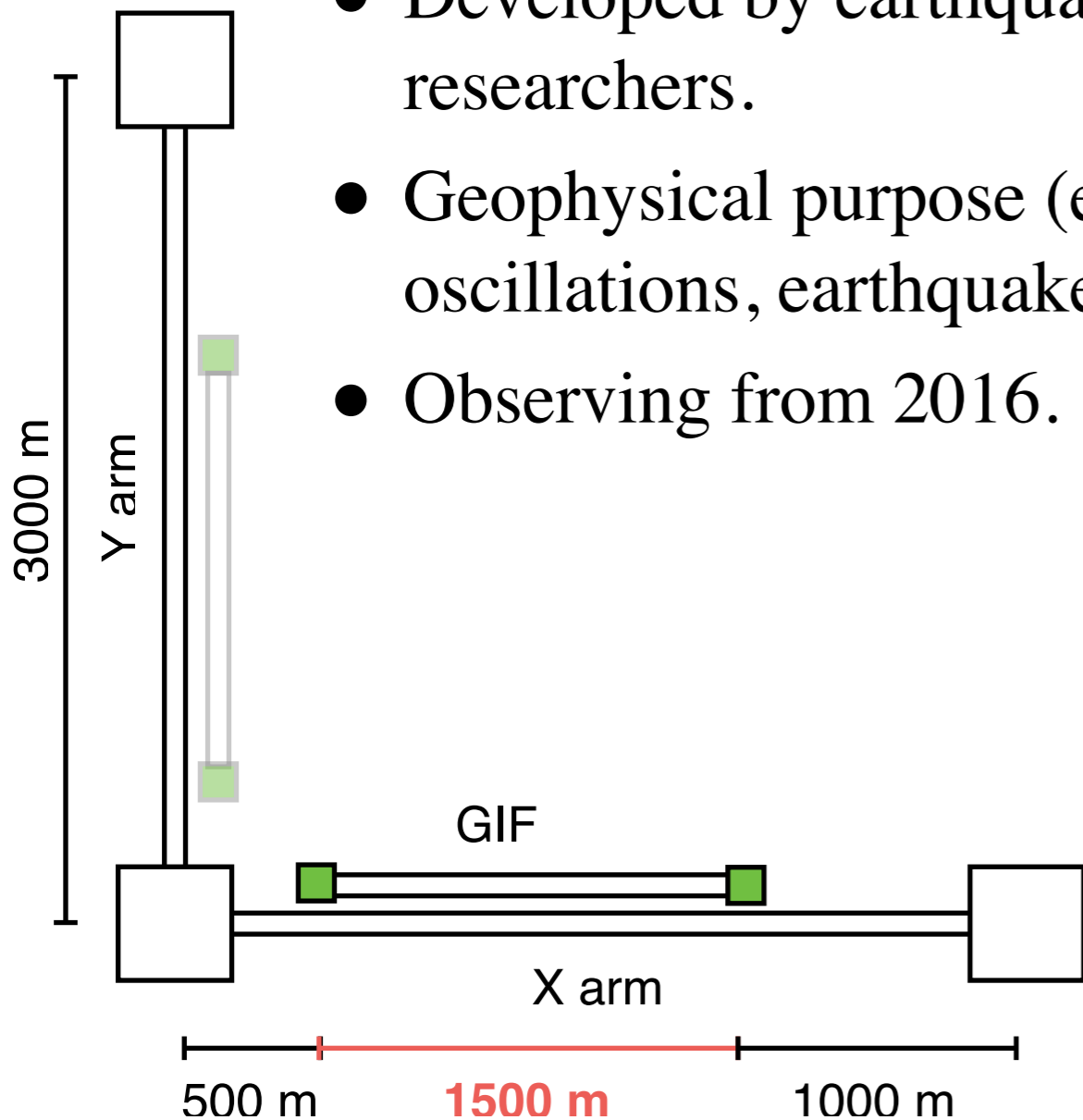

Baseline deformation measured by GIF

StrainX from 2016-12-08:12:00 to 2016-12-09:18:00 (~ 1 day)

Strain

1.3×10^{-7}

Microseisms
(1-10 sec)

Earth tides
(1/2 day)

Features of GIF

- wide dynamic range
- broadband
- stable operation

1 hour

Time [hour]

M7.8
Earthquake
(> 10 sec)



Geophysics Interferometer (GIF)

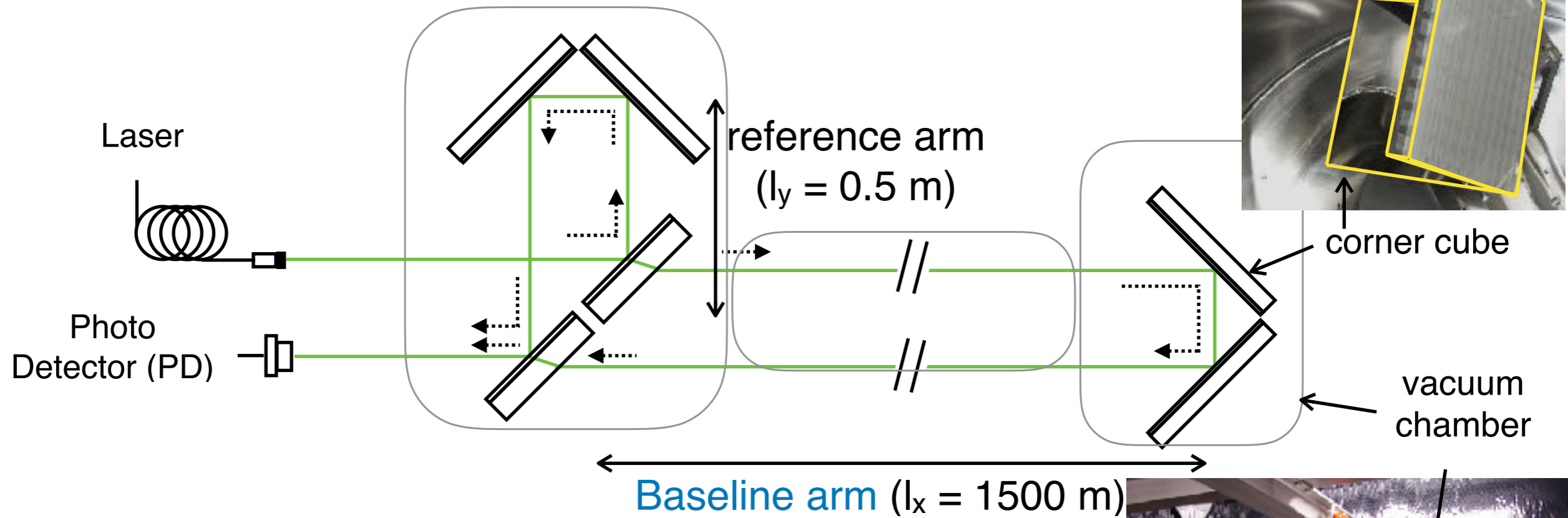

1500 m asymmetric Michelson interferometer

- Sensitive to differential arms length; $l_x - l_y$
- Use corner cubes
- No active alignment control on mirrors
- Mounted on the ground

Direct and stable measurement

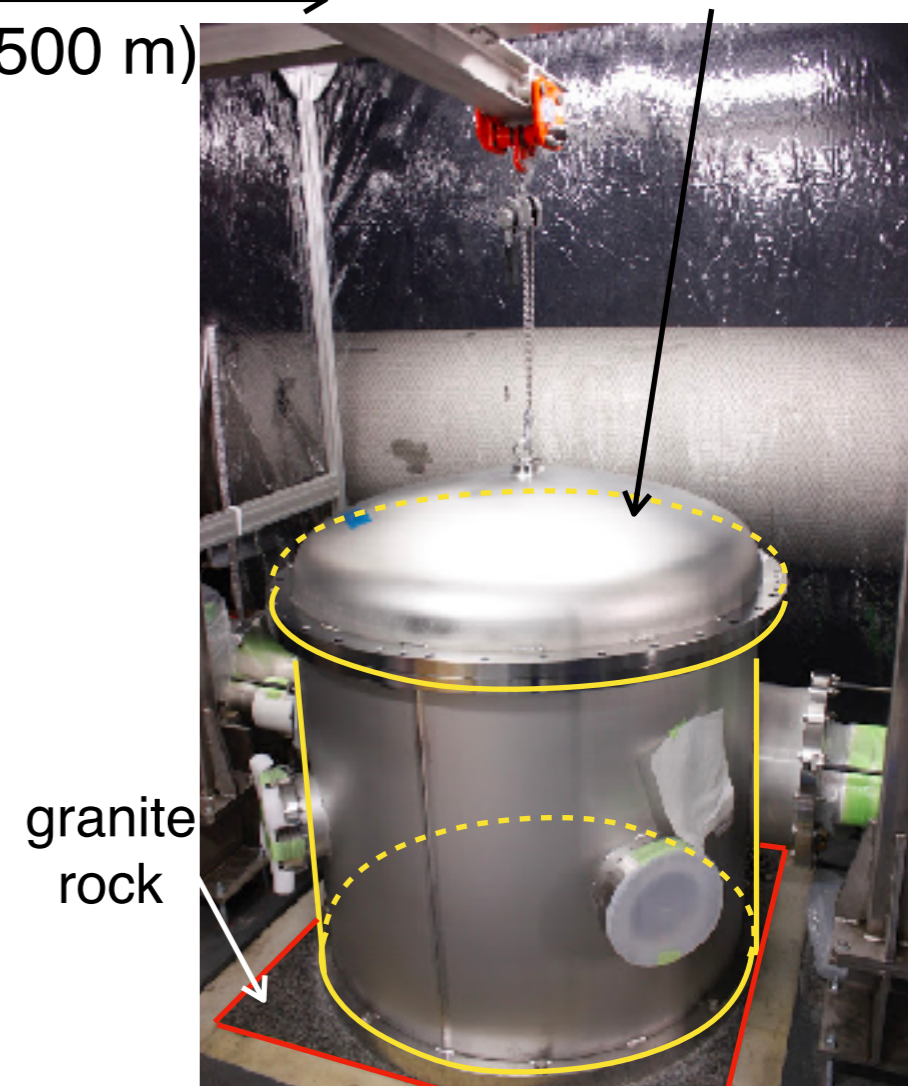

Main noise source

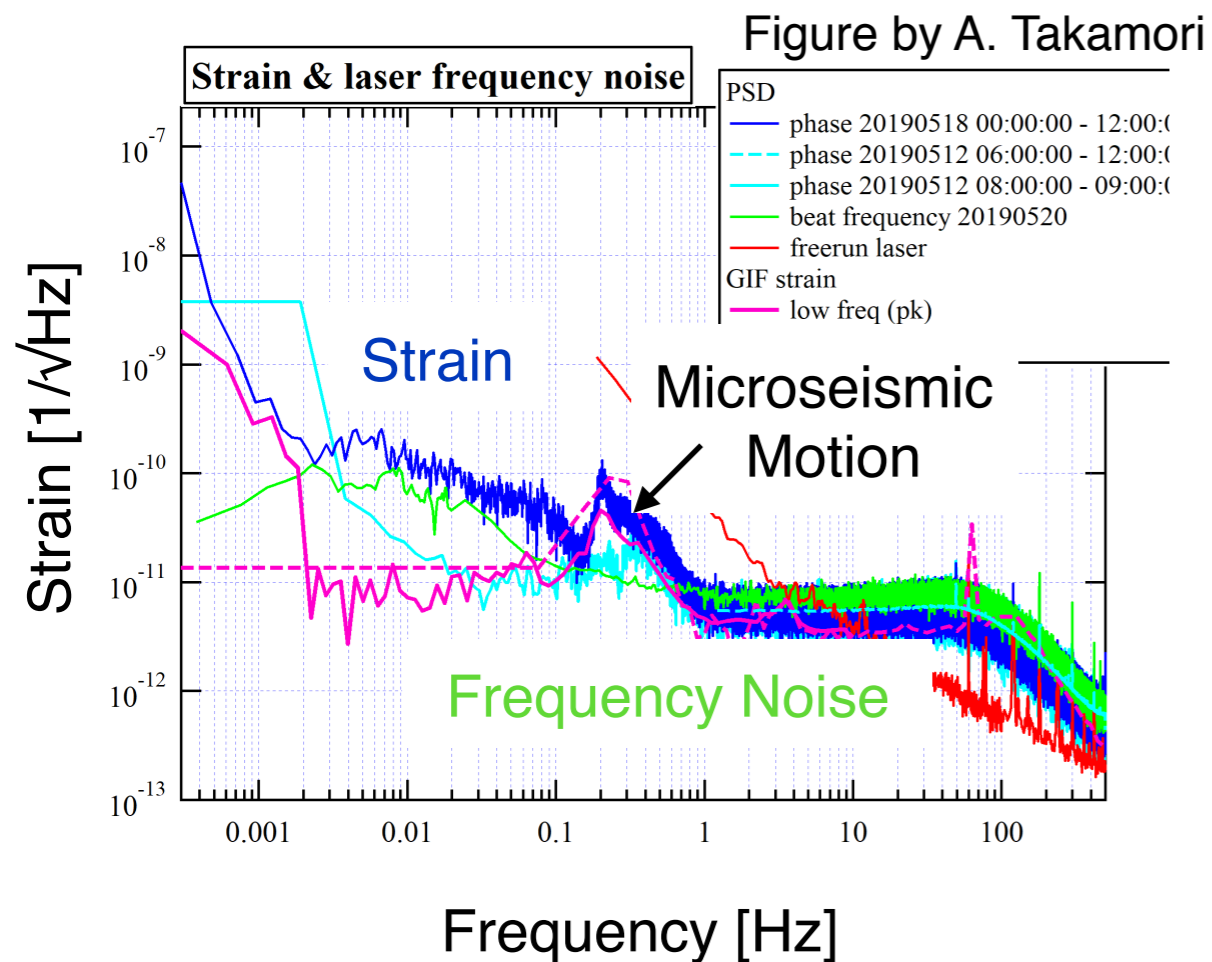
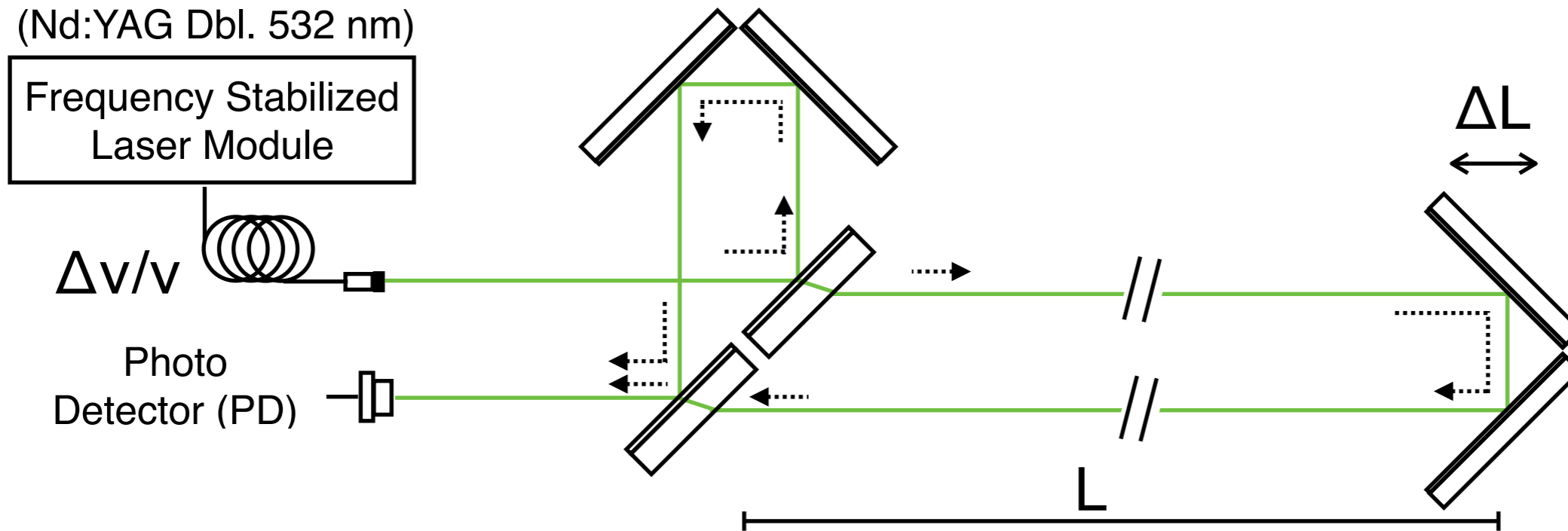

Strain resolution

- $\frac{\Delta L}{L} \sim \frac{\Delta\nu}{\nu}$

Frequency Stabilized laser

- $\Delta\nu/\nu \sim 10^{-11}$

Precise measurement ($\sim 10^{-11}$)
(below microseisms)

Signal detection (Quadrature phase detection)

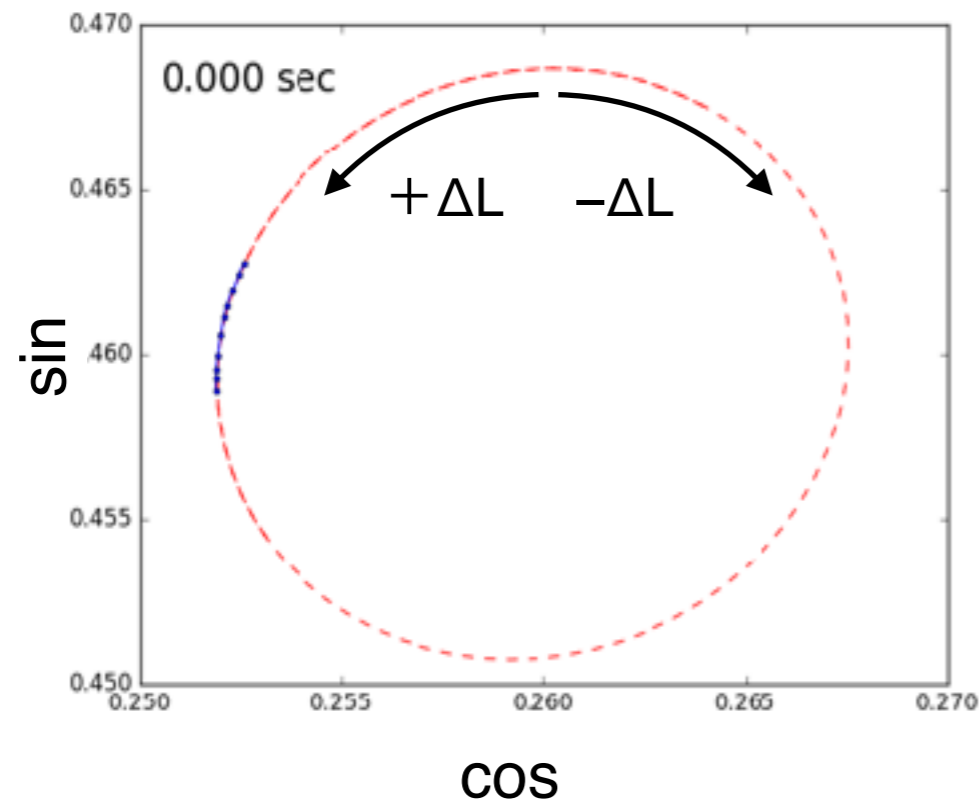
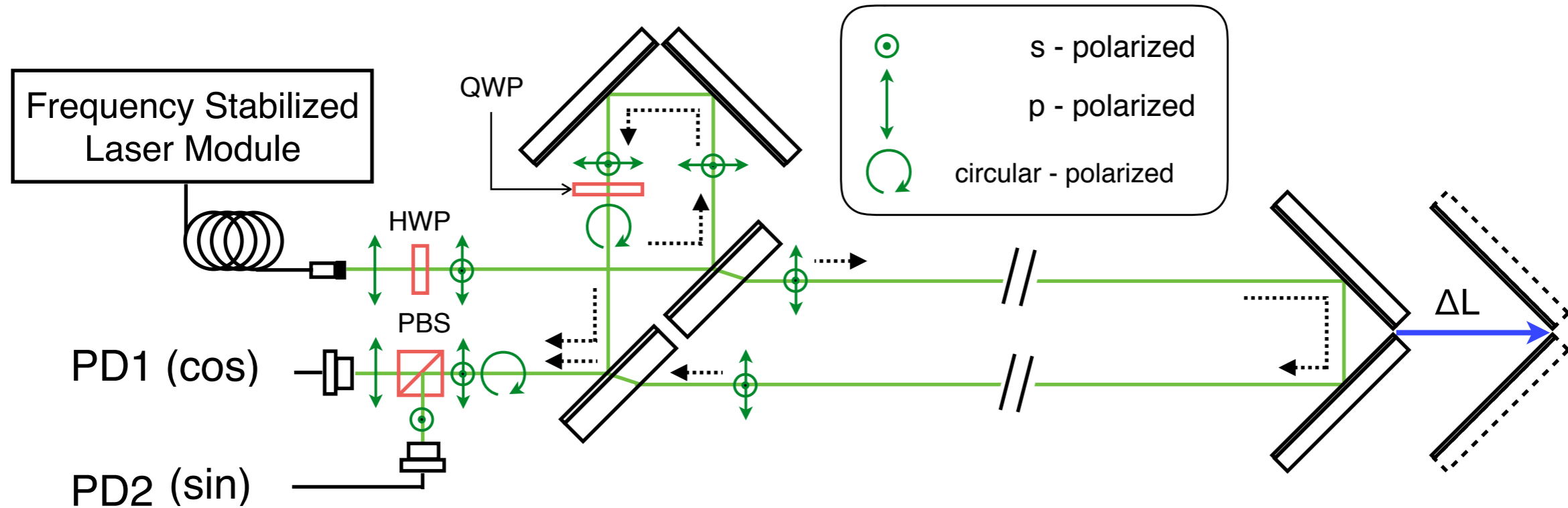

- Two fringe signals; sin and cos
- $\Delta L \rightarrow$ rotation angle

Wide dynamic range measurement

Comparison with seismometer

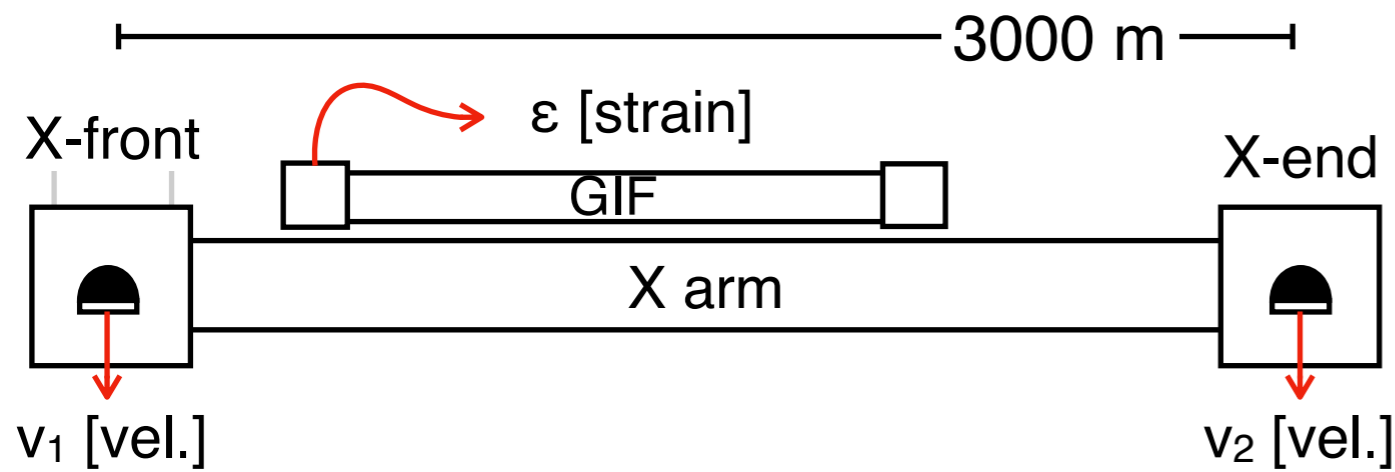

ΔL measured by two ways

$$\Delta L_{3000} = \epsilon \times 3000 \quad \dots \text{ GIF}$$

$$\Delta L_{3000} = \int (v_1 - v_2) dt \quad \dots \text{ Seismometer}$$

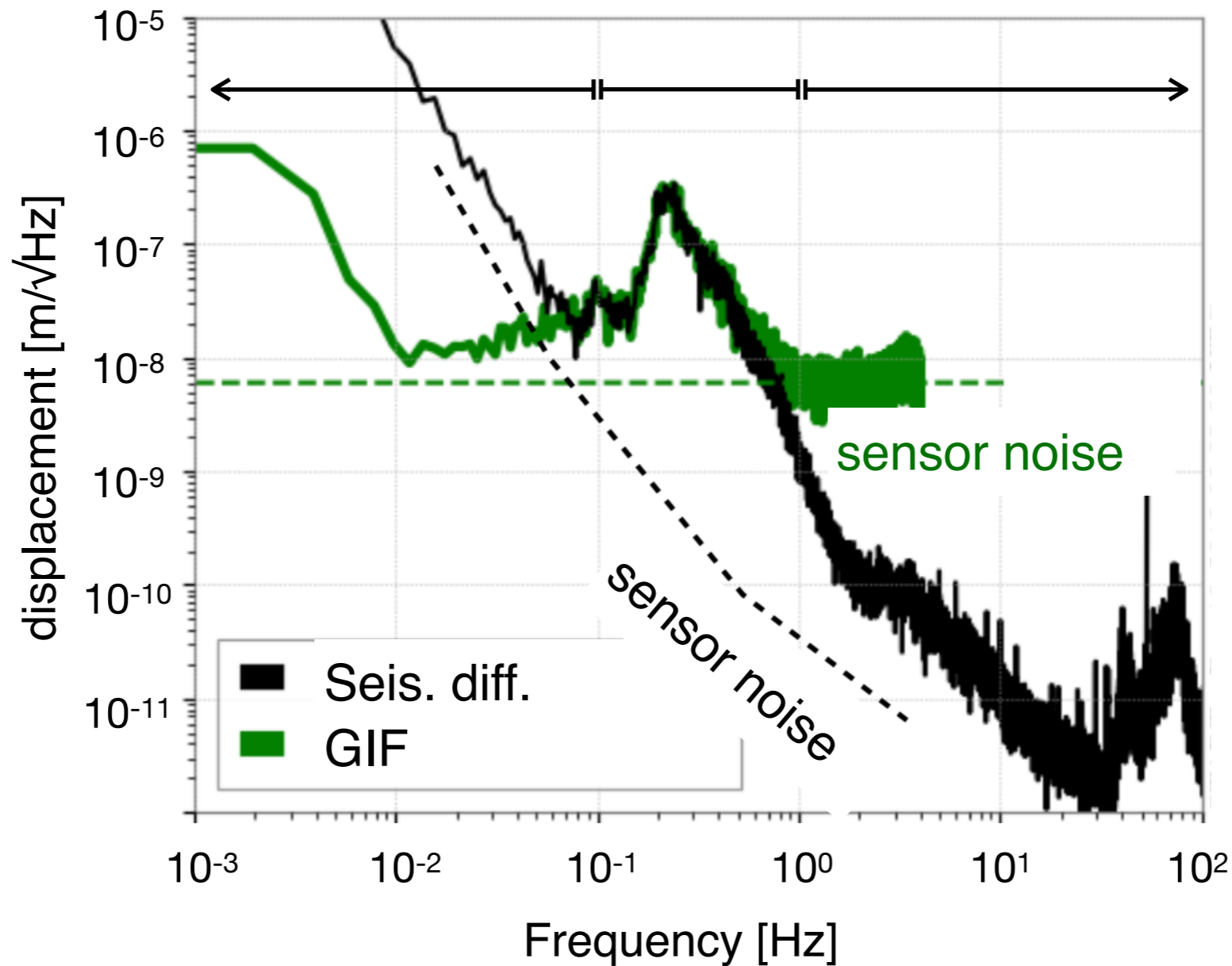

Strainmeter has a better sensitivity below 0.1 Hz than seismometer 17

Contents

1. Introduction

- Gravitational-wave (GW) and GW detector
- Problematic seismic motion for stable operation

2. Geophysics Interferometer

- Overview
- Comparison with seismometer

3. Baseline Compensation System

- **Concept**
- **Control design**

4. Demonstration and Results

- Setup for demonstration
- Result

5. Summary

- Conclusion
- Future prospects

Baseline Compensation System

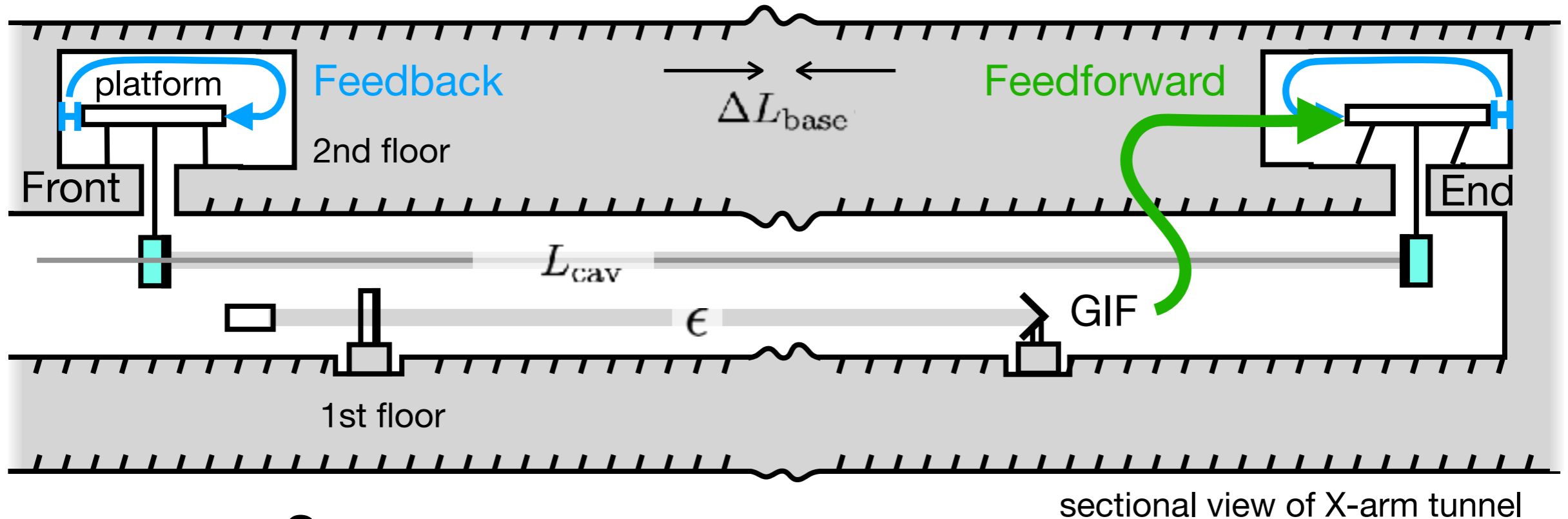

Scope

- Compensate the L_{cav} below 1 Hz
- Reduction of ΔL_{cav} below 1 Hz

Method

1. Lock the platforms to local ground
 $\rightarrow \Delta L_{cav} = \Delta L_{base} = \epsilon \times 3000$
2. Feedforward $-\Delta L_{base}$ to the end actuator
 $\rightarrow \Delta L_{cav} - \Delta L_{base} \rightarrow 0$

We need realtime signal processing for feedforward control

Realtime signal processing for KAGRA

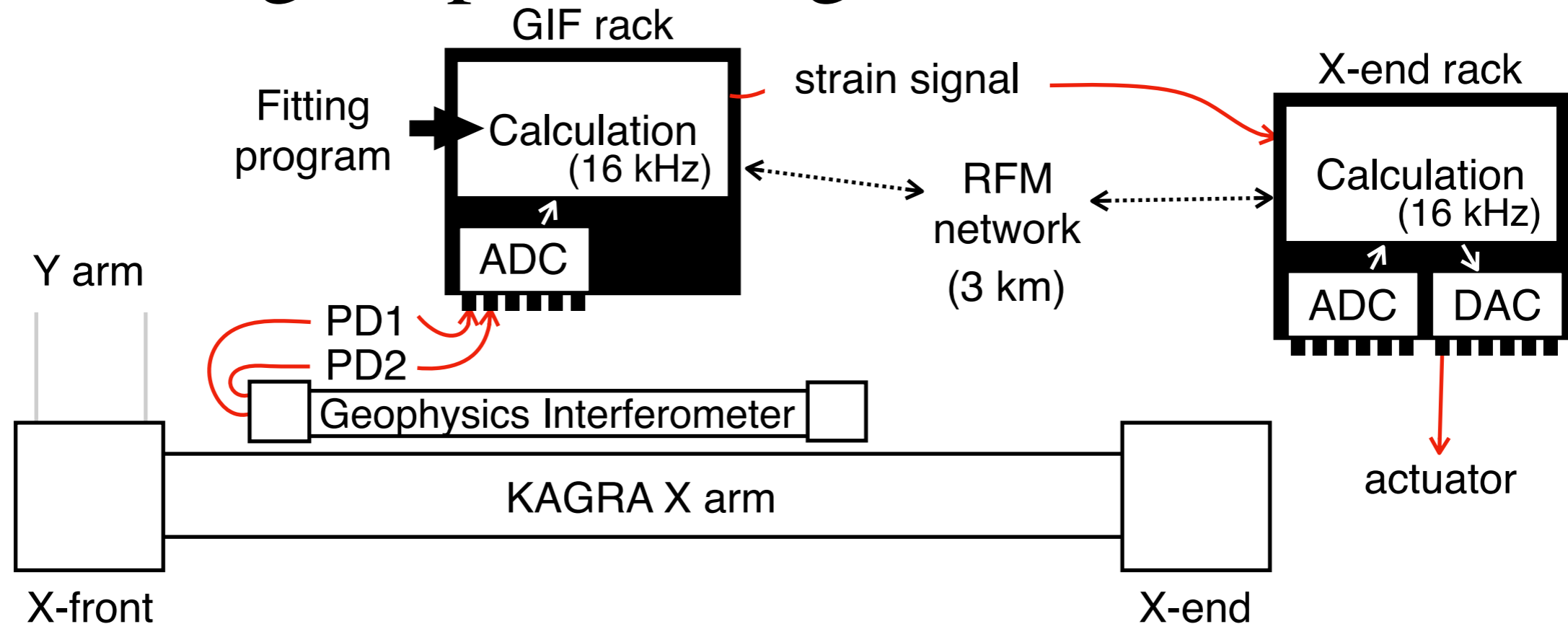

Realtime ellipse fitting (coded C language)

- 2 PD signal → strain signal
- Run every clock (1 clock = 61 usec = 1/16 kHz)

Synchronized with the other computer

- Latency is 1 clock
- e.g. Strain signal → actuator at X-end

Control of Platform

Front platform

Sensor&Actuator Module

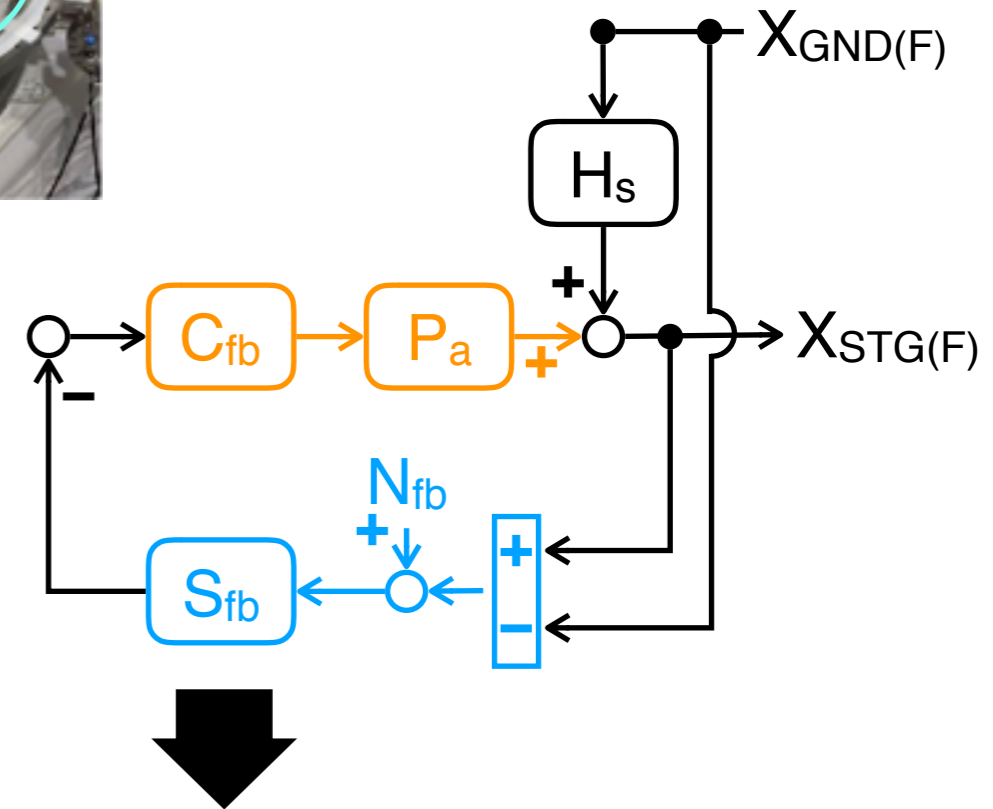
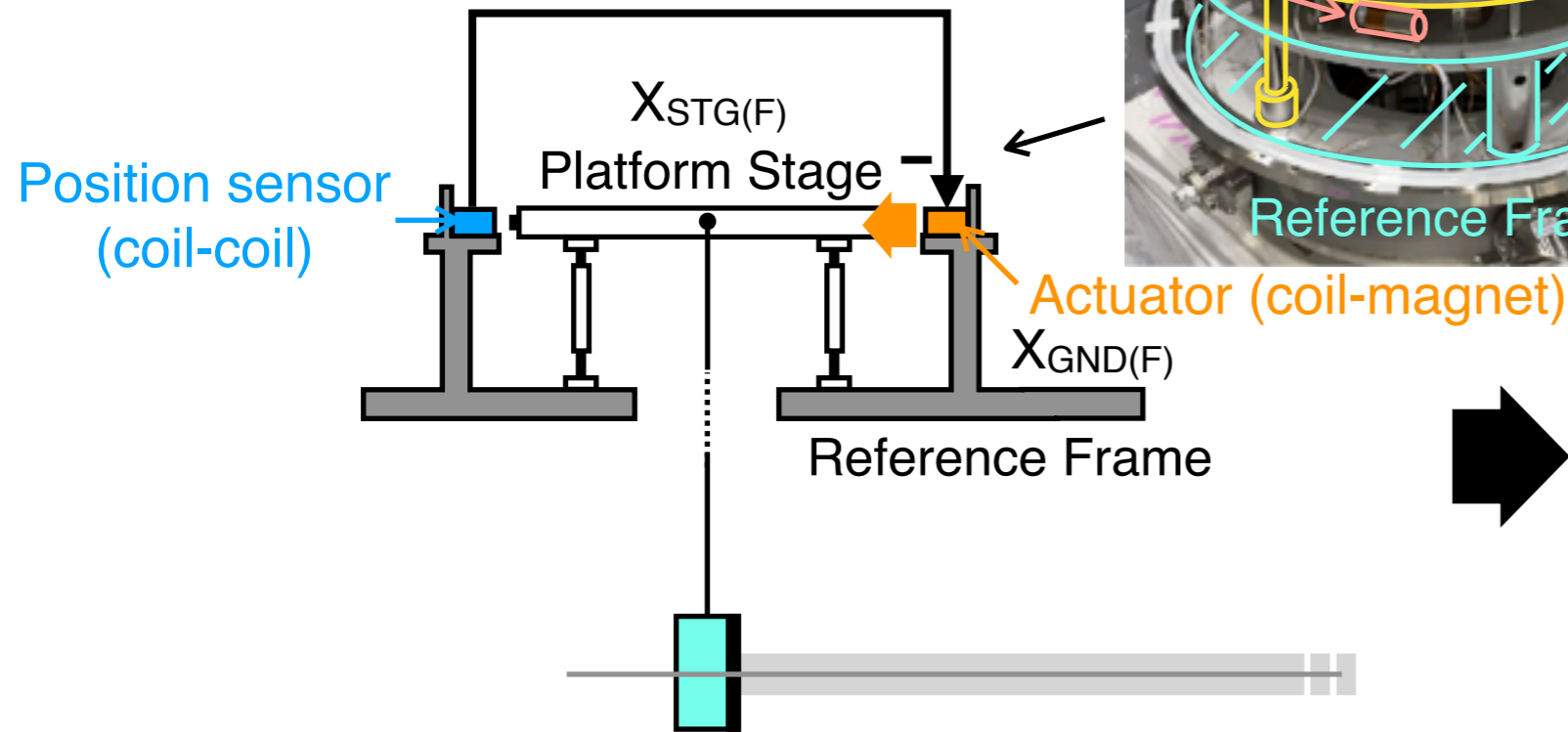
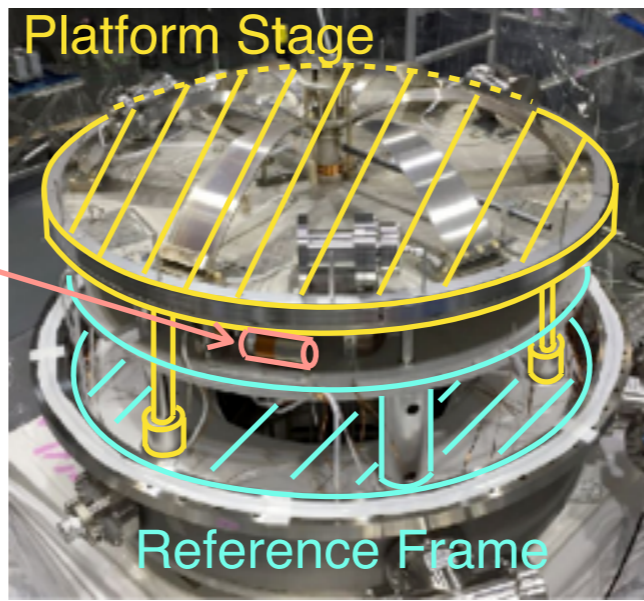

$$X_{STG(F)} = \frac{G}{1+G} X_{GND(F)} + \frac{1}{1+G} H_s X_{GND(F)} - \frac{G}{1+G} N_{fb}$$

$(G = C_{fb} P_a S_{fb})$

$G \gg 1$

$$X_{STG(F)} = X_{GND(F)} - N_{fb}$$

Front stage is locked to the local ground by feedback control. 21

Control of Platform

End platform

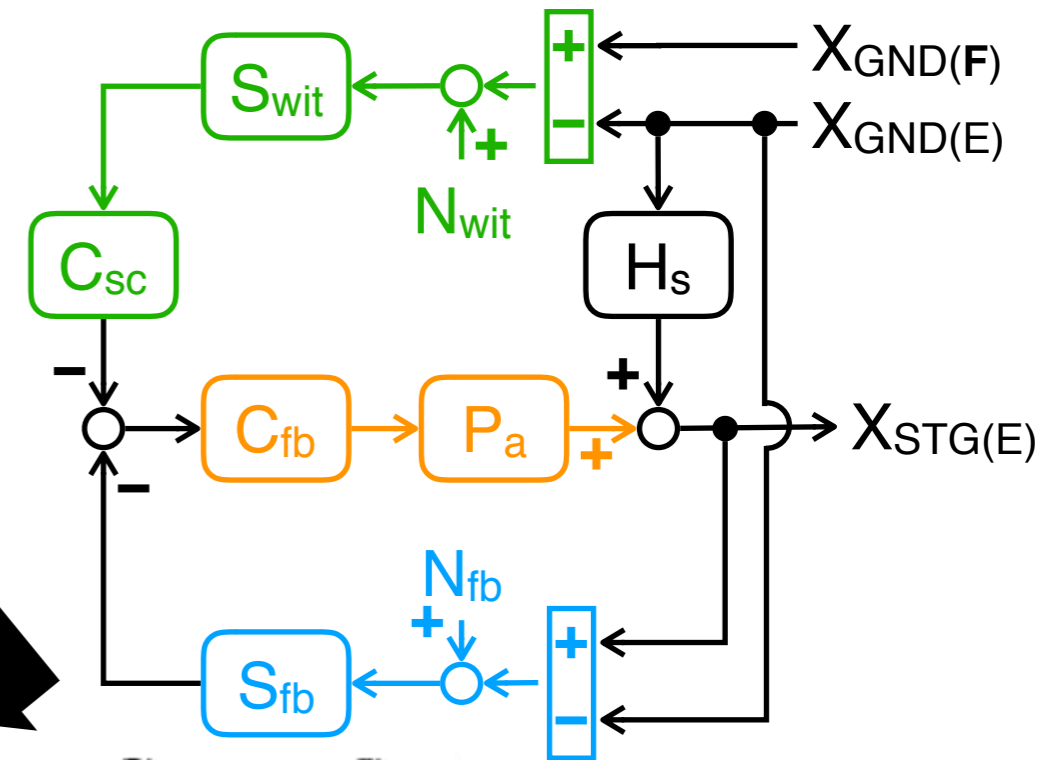
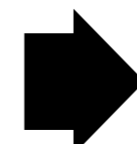
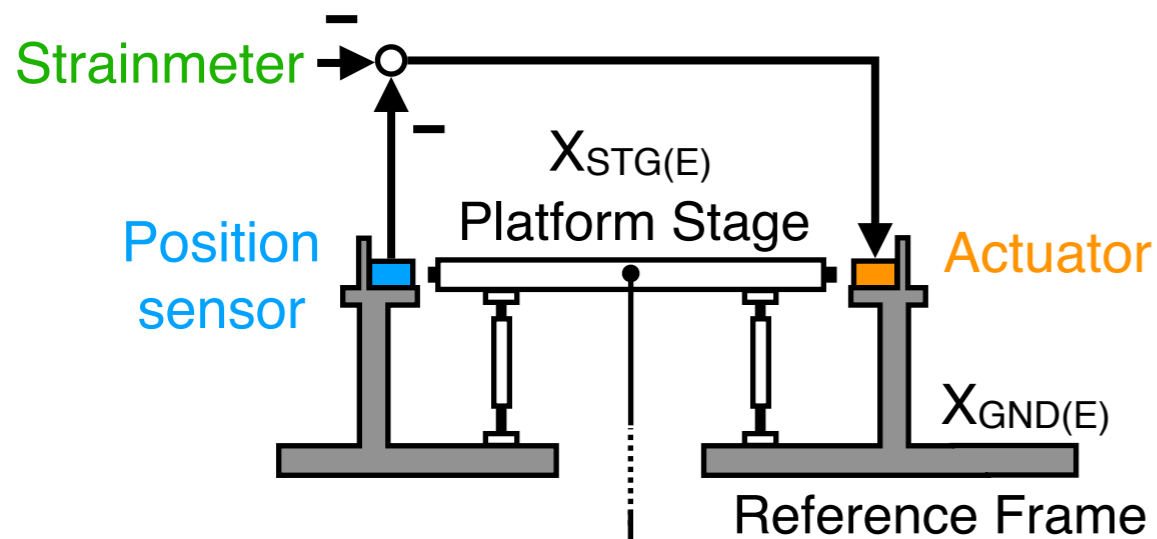

$$X_{STG(E)} = \frac{G}{1+G} \left(1 - C_{sc} \frac{S_{wit}}{S_{fb}} \right) X_{GND(E)} + \frac{G}{1+G} C_{sc} \frac{S_{wit}}{S_{fb}} X_{GND(F)}$$

$$G \gg 1 \dashrightarrow + \frac{1}{1+G} H_s X_{GND(E)} - \frac{G}{1+G} \left(N_{fb} + C_{sc} \frac{S_{wit}}{S_{fb}} N_{wit} \right)$$

$$C_{sc} \frac{S_{wit}}{S_{fb}} = 1 \dashrightarrow X_{STG(E)} = \underbrace{\left(1 - C_{sc} \frac{S_{wit}}{S_{fb}} \right)}_{\text{Reduction factor}} X_{GND(E)} + C_{sc} \frac{S_{wit}}{S_{fb}} X_{GND(F)} - \left(N_{fb} - C_{sc} \frac{S_{wit}}{S_{fb}} N_{wit} \right)$$

$$X_{STG(E)} = X_{GND(F)} - N_{fb} - N_{wit}$$



$$\Delta L_{cavity} = X_{STG(F)} - X_{STG(E)} = -N_{fb(F)} + N_{fb(E)} + N_{wit}$$



ΔL_{cav} can be reduced to the sensor noise level.

Contents

1. Introduction

- Gravitational-wave (GW) and GW detector
- Problematic seismic motion for stable operation

2. Geophysics Interferometer

- Overview
- Comparison with seismometer

3. Baseline Compensation System

- Concept
- Control design

4. Demonstration and Results

- Setup for demonstration
- Results and discussion

5. Summary

- Conclusion
- Future prospects

Setup for Demonstration

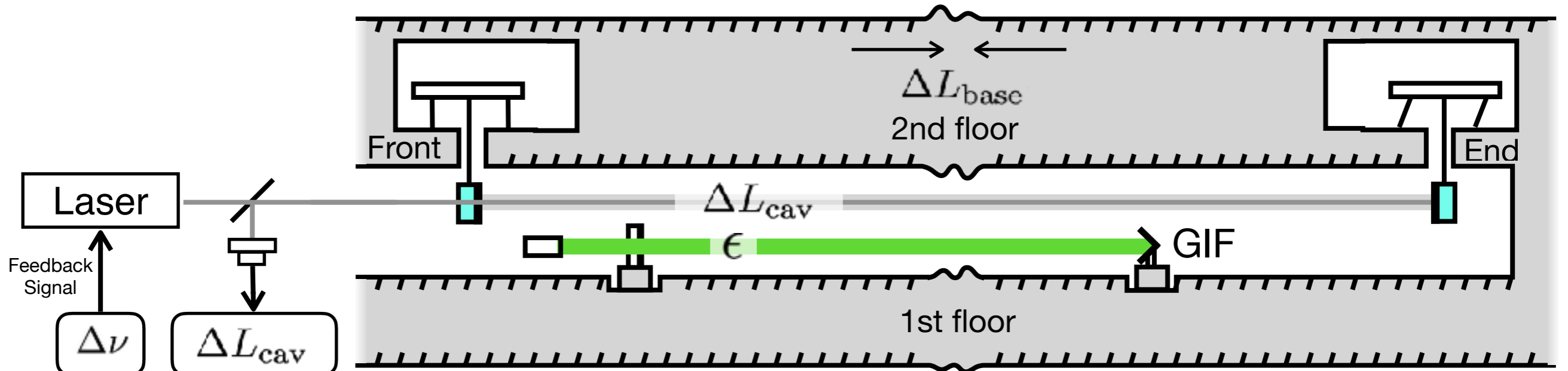

Purpose

- Evaluation of the ΔL_{cav} reduction when compensating

ΔL_{cav} measurement

- Lock the cavity by changing the laser frequency
- $\Delta L_{cav} \propto$ feedback signal

ΔL_{base} measurement

- Use strainmeter
- $\Delta L_{base} = \epsilon \times 3000$

Results : Time domain

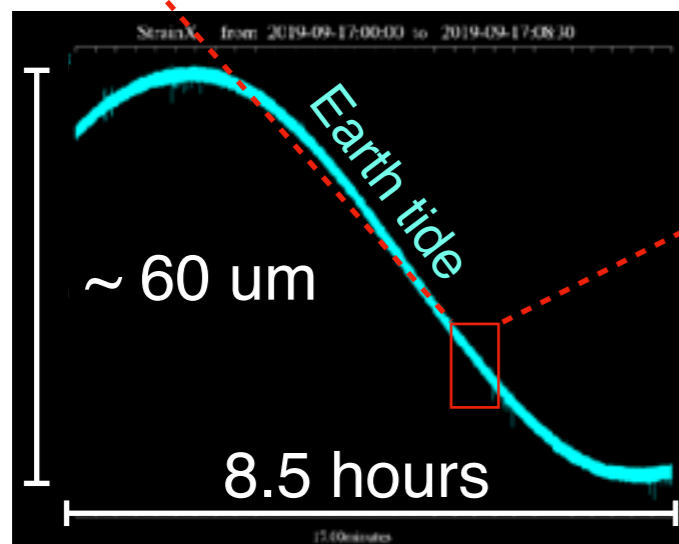
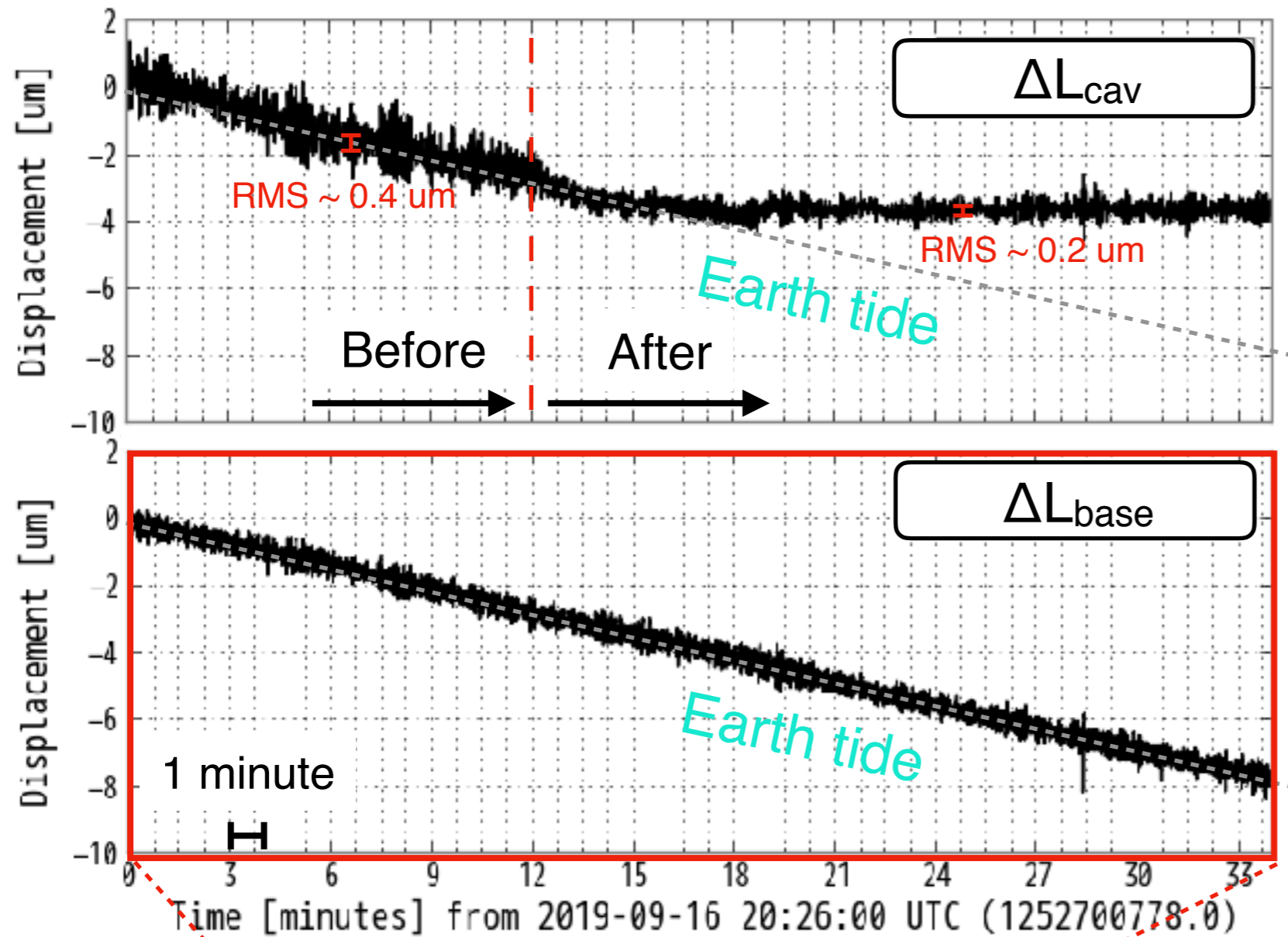

Reduction

- Tidal drift
- RMS in 1 minutes

Results : Frequency domain

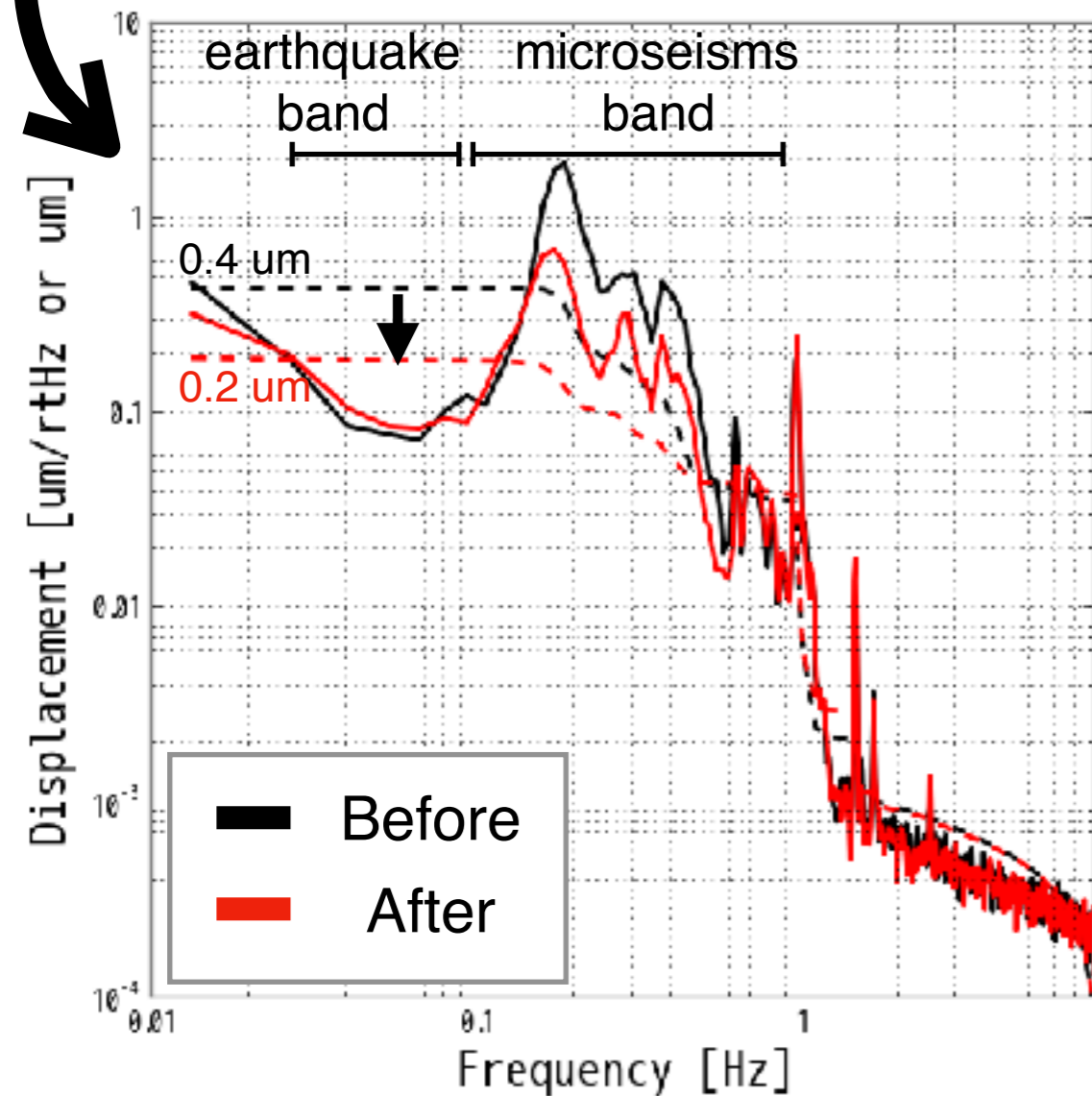
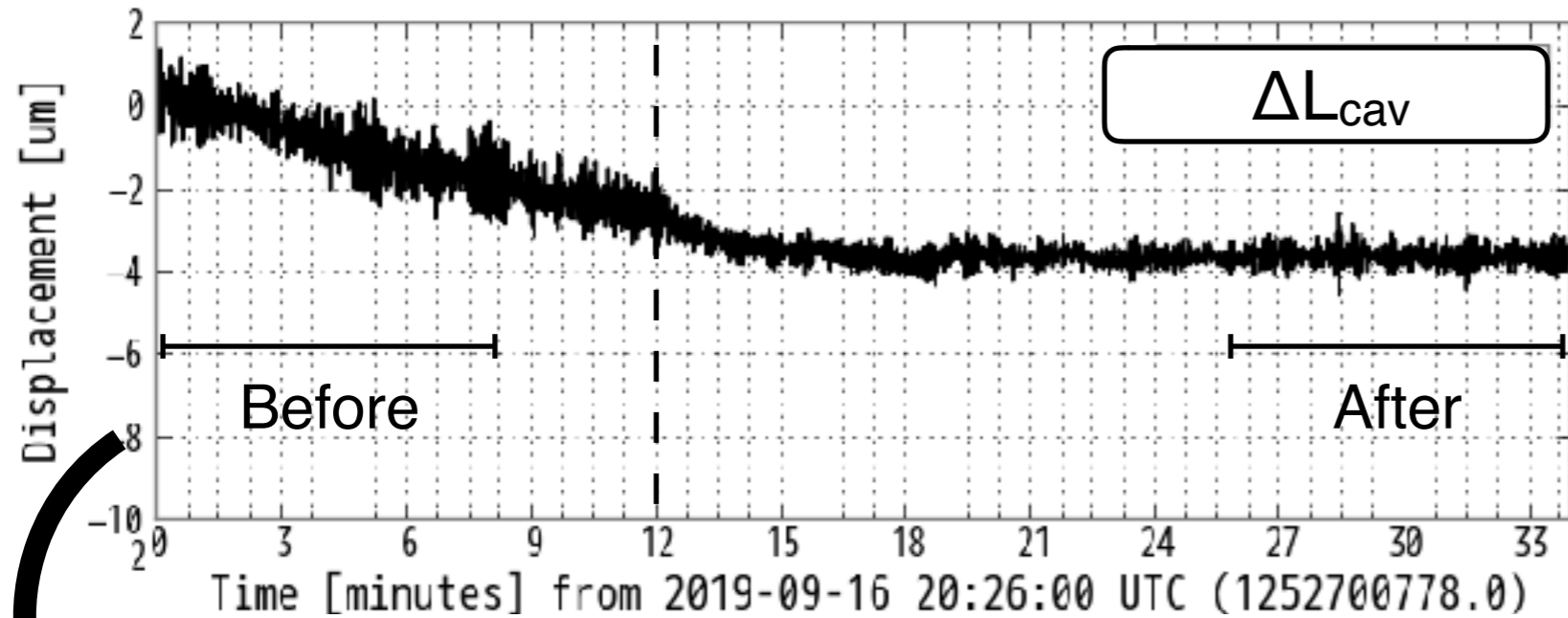

RMS above 0.01 Hz is reduced by 1/2 (-6 dB)

- Mainly in the microseismic band
- No reduction in earthquake band

Discussion : Earthquake band

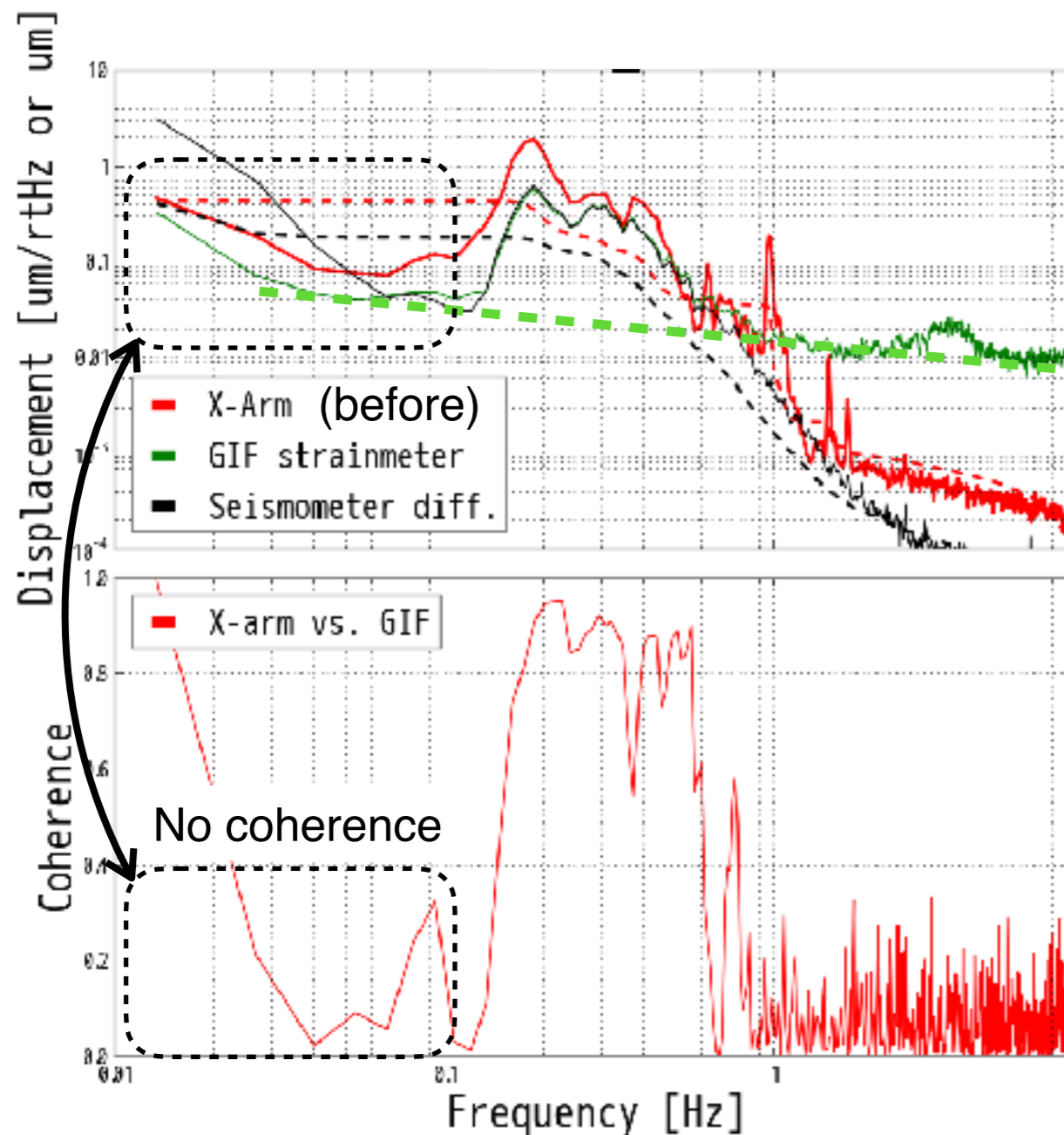

GIF noise

In earthquake band,

- No coherence
- GIF is covered by own noise

There are no reduction because of GIF noise

Discussion : Reduction rate

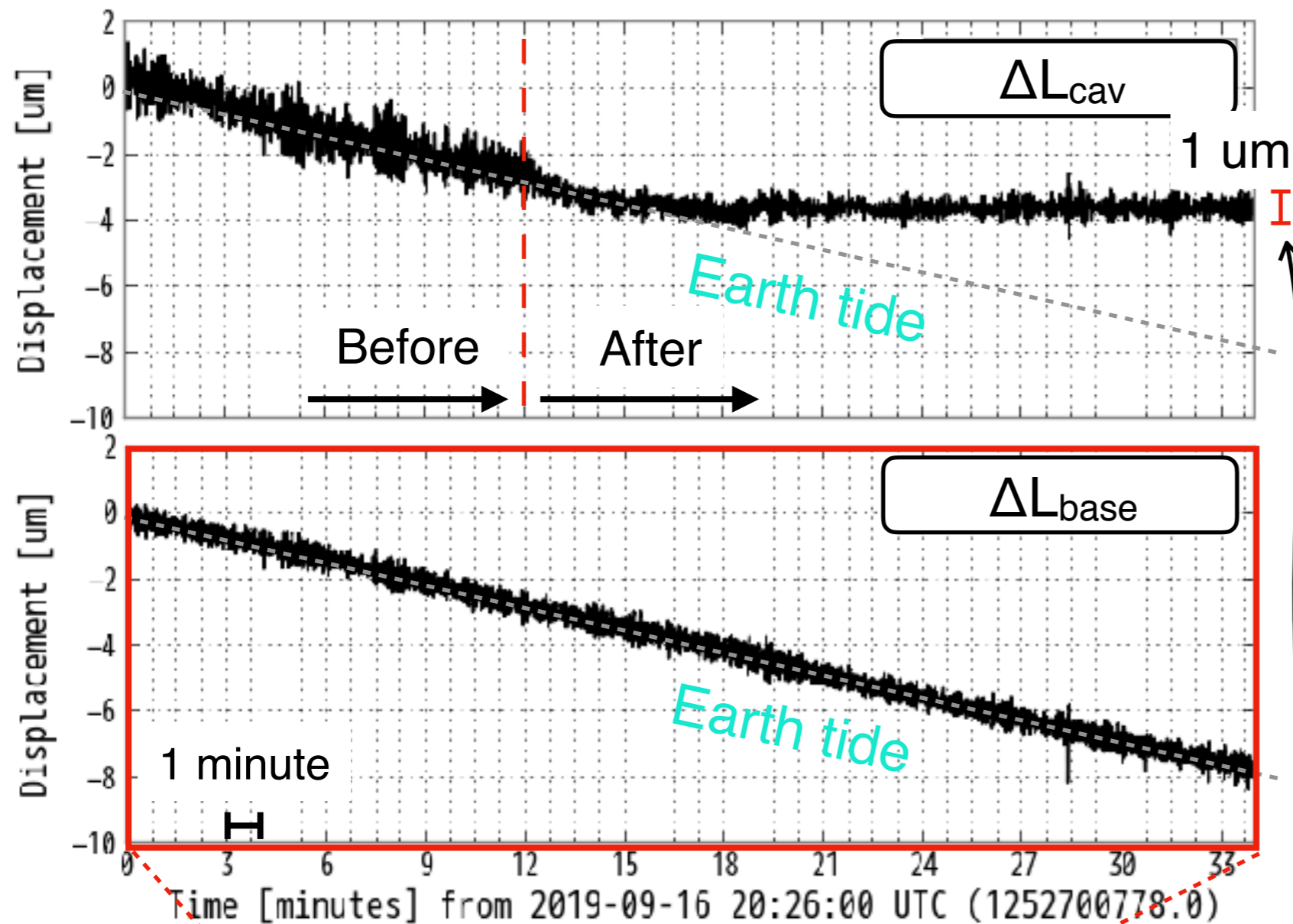

Reduction rate should be less than -6 dB.

$$\text{Reduction rate} = \left(1 - C_{sc} \frac{S_{wit}}{S_{fb}} \right)$$

- Error of $\frac{S_{wit}}{S_{fb}} < 5\%$
- Reduction rate should be less than 1/20 (-26 dB)

Actual case,

- RMS in 20 minutes $< 1 \mu\text{m}$
- If demonstration is continued, reduction rate will be 1/60 (-35 dB)

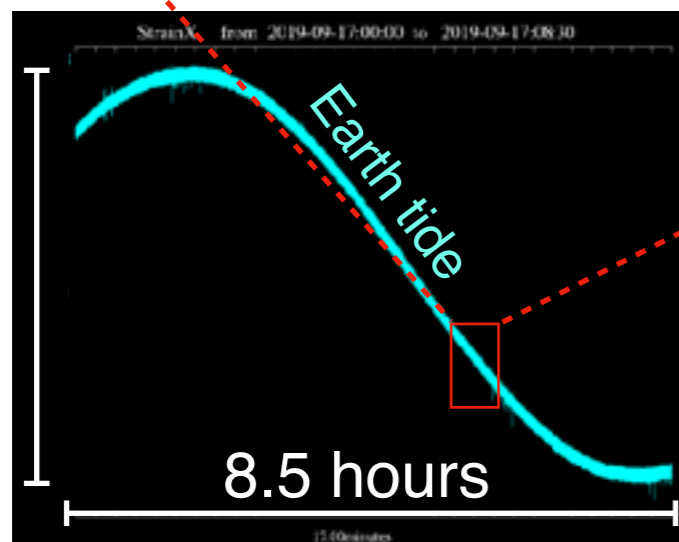

Reduction rate in microseismic band might be limited by some reason.

Discussion : Microseismic band

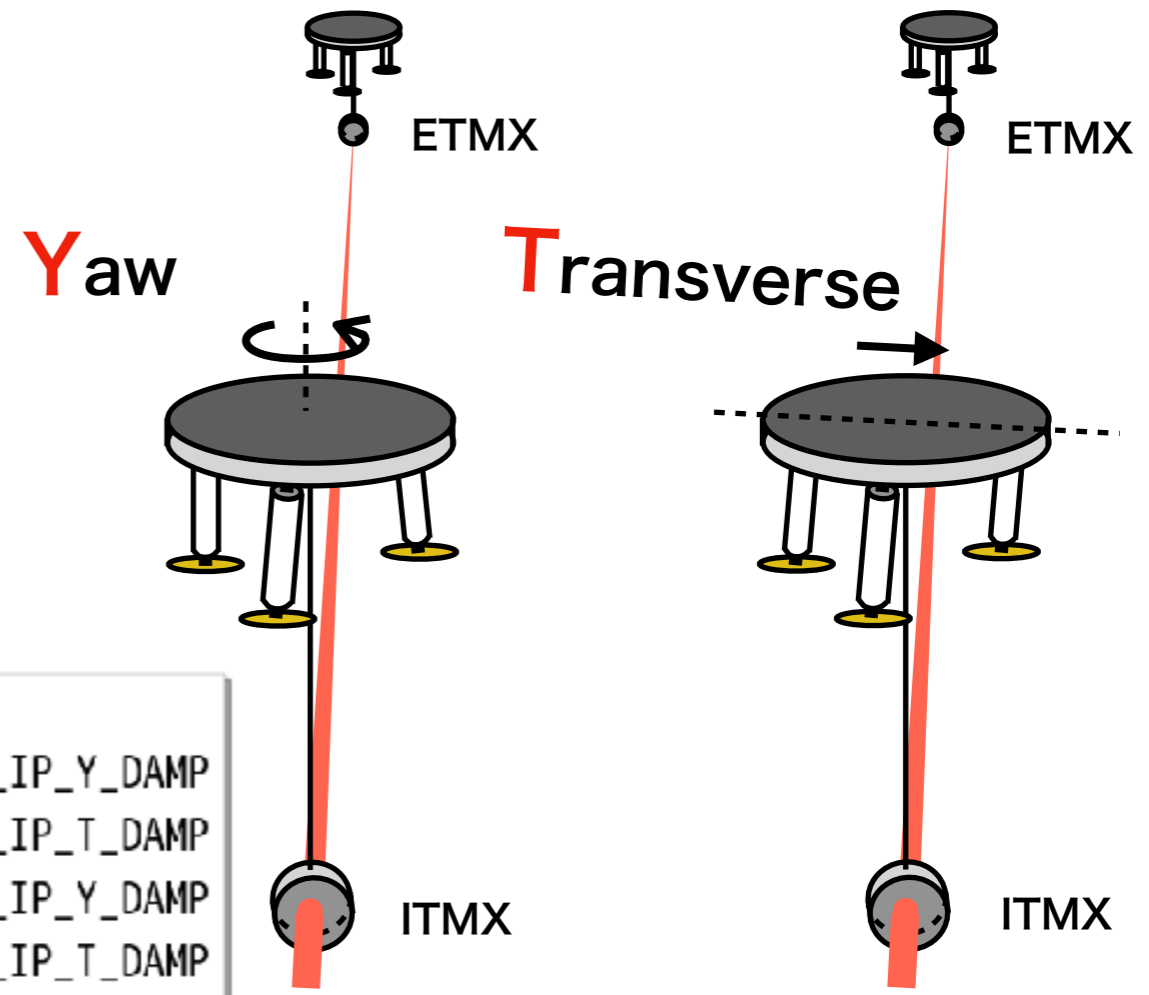
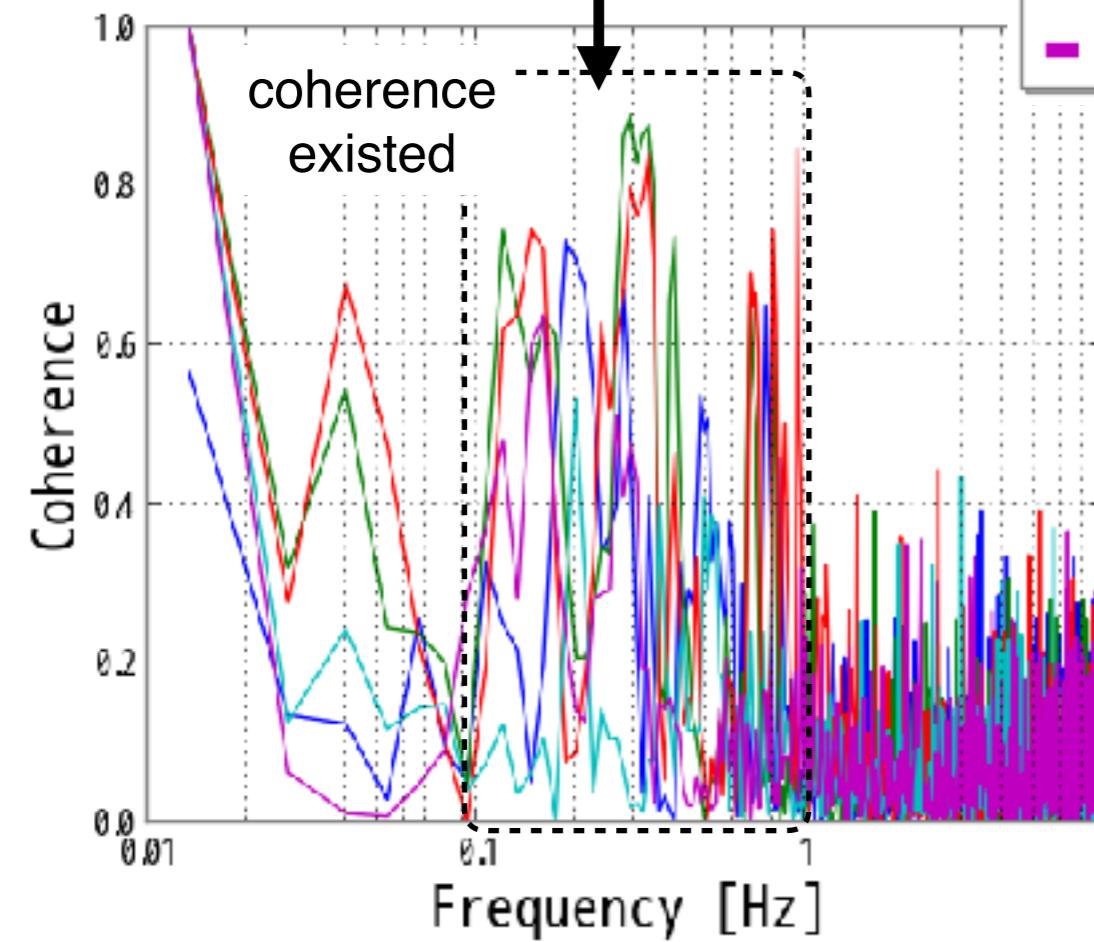
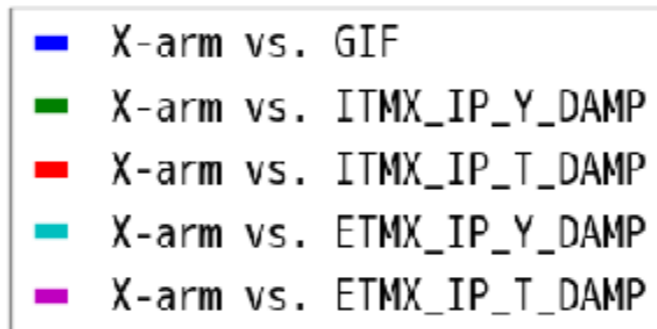
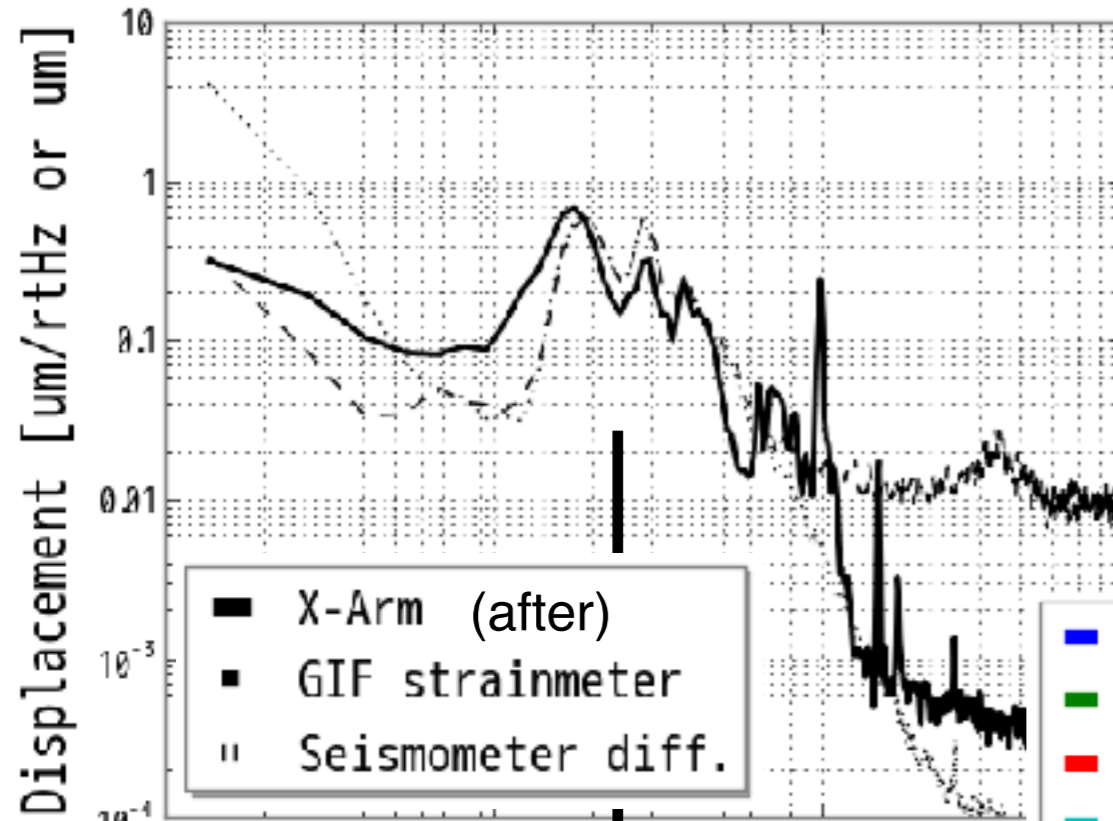

Implication of signal coupling

- Coherence between X-arm and other degrees of freedoms (DOFs).

Reduction of -6 dB might be limited by the couplings

Contents

1. Introduction

- Gravitational-wave (GW) and GW detector
- Problematic seismic motion for stable operation

2. Geophysics Interferometer

- Overview
- Comparison with seismometer

3. Baseline Compensation System

- Concept
- Control design

4. Demonstration and Results

- Setup for demonstration
- Results and discussion

5. Summary

- Conclusion
- Future prospects

Conclusion

- Duty cycle is limited by low-frequency seismic noises
 - Microseismic noise (0.1 - 1 Hz)
 - Large earthquake (0.03 - 100 mHz)
 - Earth tides (1 day)
- I designed the baseline compensation system and demonstrate its performance by using X-arm cavity of KAGRA.
- As a result, there are reduction owing to the compensation
 - -6 dB reduction in microseismic band
 - No obvious reduction in earthquake band
 - More than -35 dB reduction in earth tide band
- This is the first demonstration of the baseline compensation on the km-scale GW detector in the world.

Future Prospects

Reduction in microseismic band will improve the unstable operation of KAGRA due to bad weather. →

Reduction in earthquake band will improve the duty cycle of all GW detectors.

Reduction in earth tide will relax the hierarchical feedback control, and GW detector will lock the cavity easily. This advantage will improve the duty cycle of all detectors. ↘

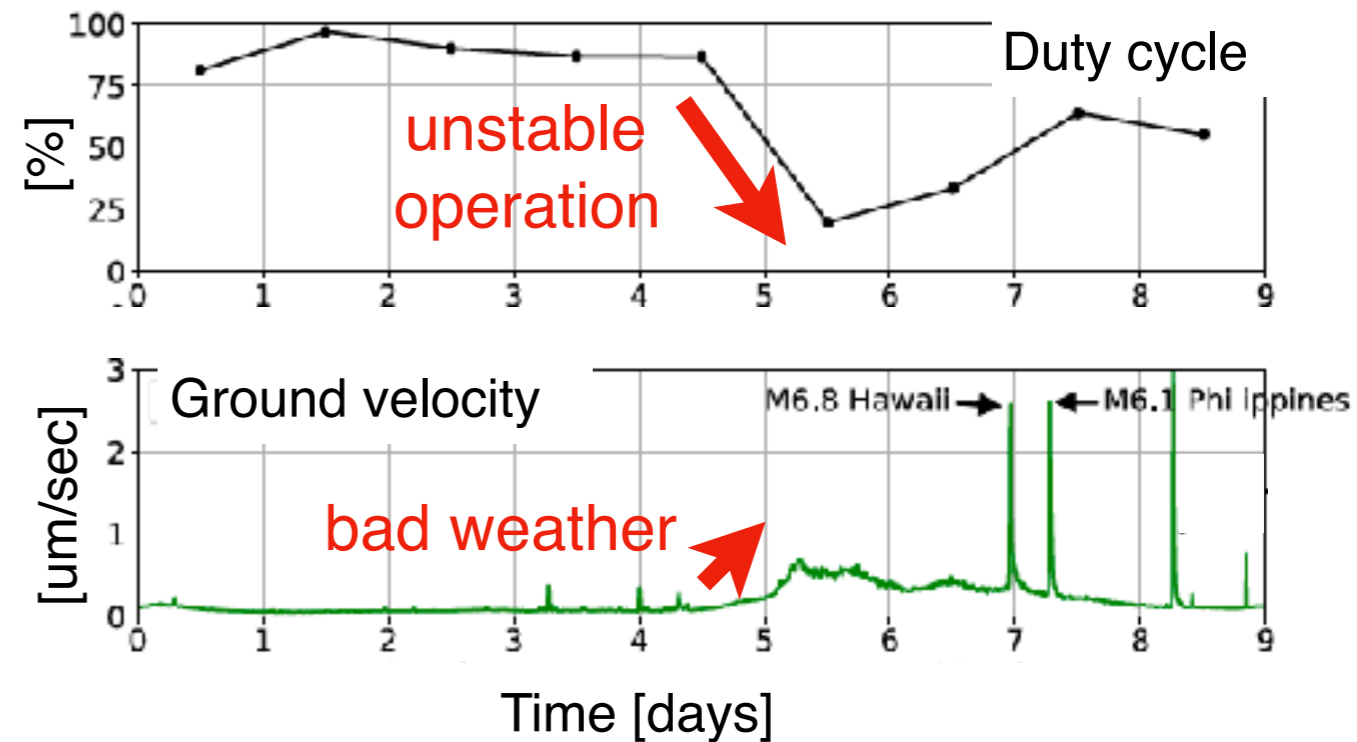

T Akutsu et al. Class. Quantum Grav. 36 (2019) 165008

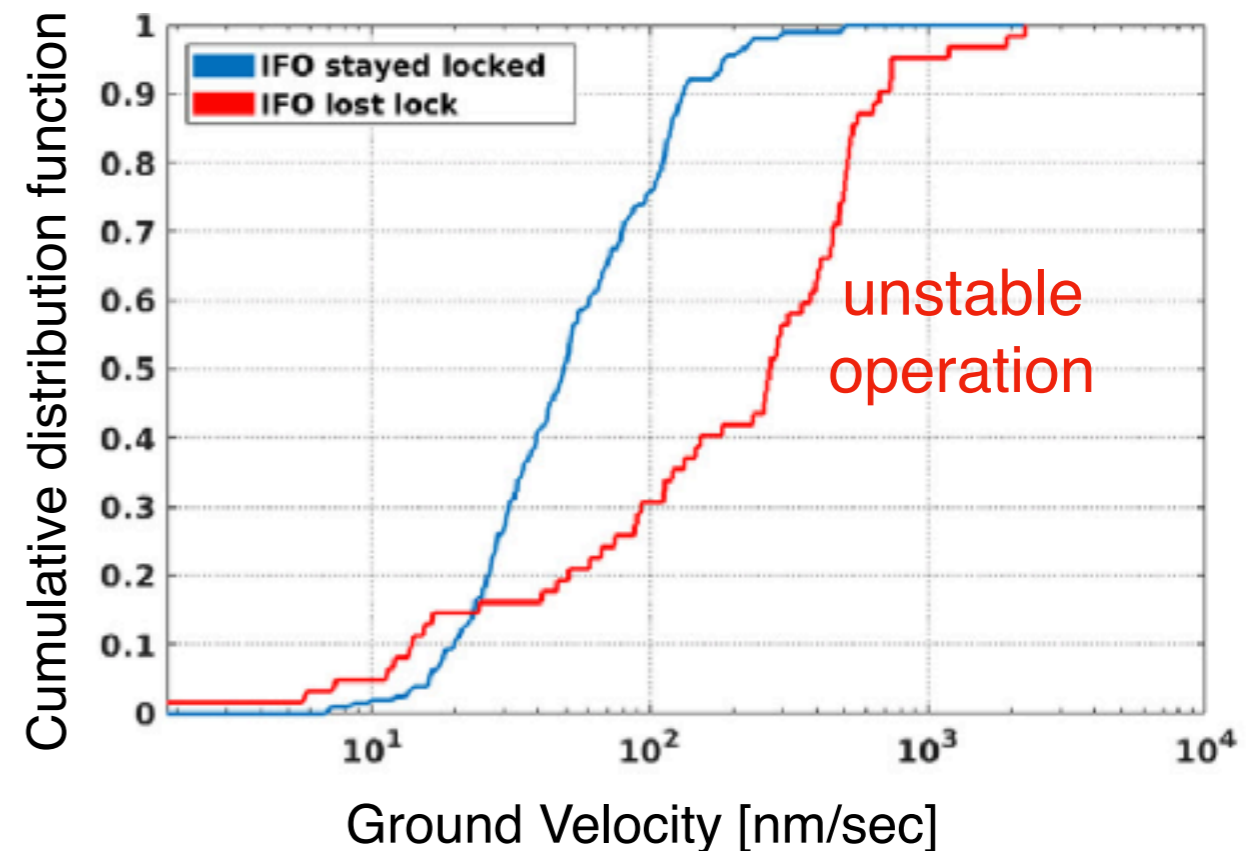

S Biscans et al. Class. Quantum Grav. 35 (2018) 055004

Future Prospects

- When the baseline compensation system is installed in the all of GW detectors, the network duty cycle will improve.
- Longer duty cycle will enhance the GW astronomy.
- GW astronomy will discover new astrophysical phenomena, and provide some knowledge of the universe to us.

