

# Polarization issue in PRC

Matteo Leonardi

Koji Nagano

Yuta Michimura

# The Situation

- ITM reflection has some p-pol, while forward beam is almost purely s-pol

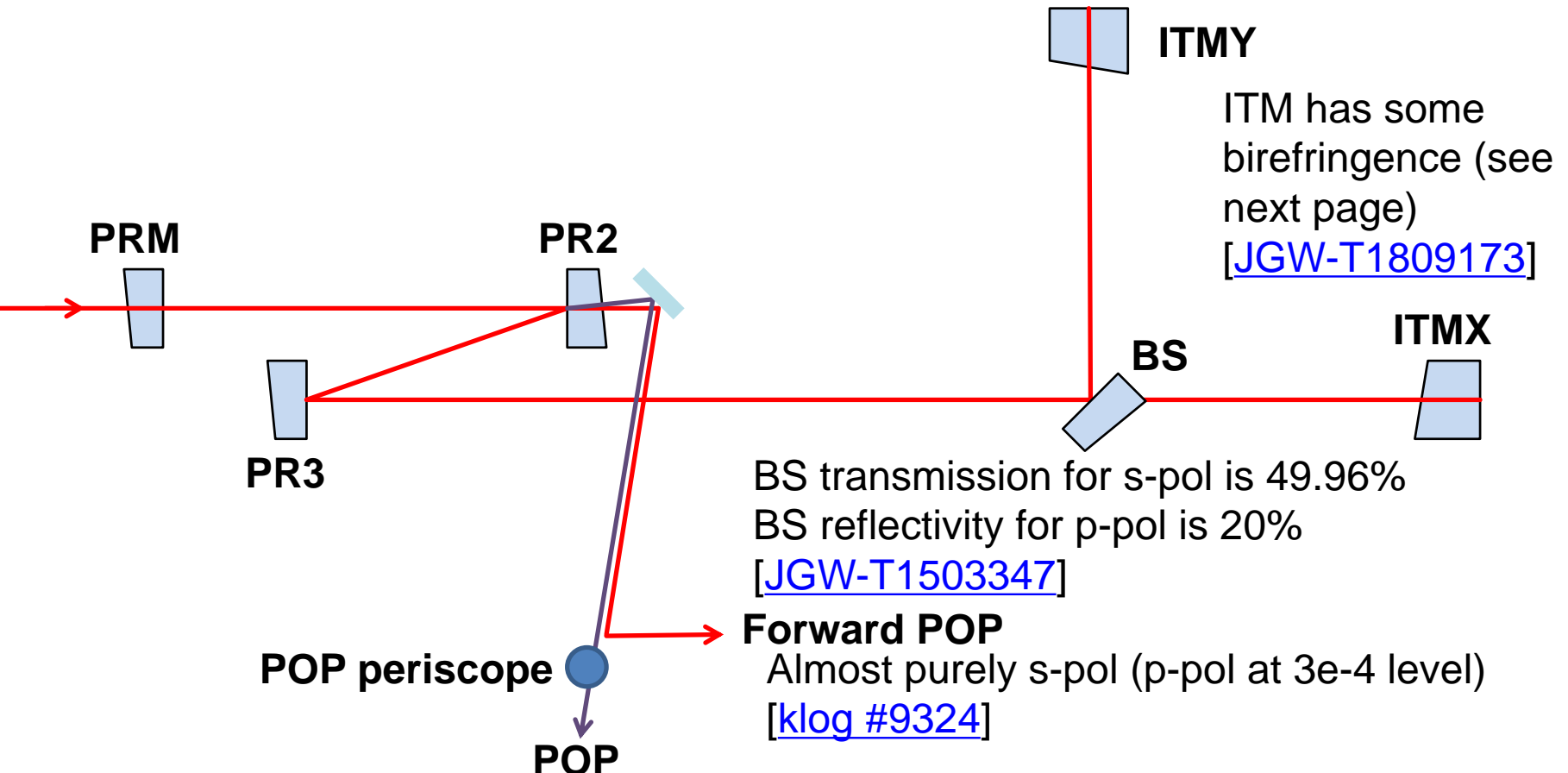

9.4 % p-pol from ITMX single bounce

4.6 % p-pol from ITMY single bounce [\[klog #9314\]](#)

# ITM Birefringence

- Vendor measured transmission wavefront error (TWE) with circular polarization, but TWE measured with s-pol was different

[JGW-T1809173](#)

	specification	vendor report	measured
ITMX	< 6nm	3.47	25.9nm
ITMY	< 6nm	4.07	30.1nm

Table 6. figure error of TWE at 140mm aperture

- This suggests that ITM has some birefringence
- Optical path length difference between two polarizations  $\Delta l_b$  gives phase difference of

$$\alpha = 2\pi\Delta l_b/\lambda$$

# ITM Birefringence

- If we treat RMS linearly,  $\Delta l_b$  can be written as
$$\Delta l_b = l_o - l_{e'} = 2l_u - 2l_{e'}$$
where  $l_{u/o/e'}$  are the optical path length measured with circular polarization ( $\sim 5$  nm RMS by vendor) and polarization aligned with o/e' axes ( $\sim 30$  nm RMS by Caltech)
- *Maximum* power loss due to s-pol turning into p-pol is  $\rho = (1 - \cos 2\alpha)/2 \simeq \alpha^2$  (2 for round-trip in ITM)
- The power loss will be 7.0% for X and 9.5% for Y
- This corresponds to the power ratio at POP (p/(s+p)) of 9.6 % for X and 5.8 % for Y (note that BS reflectivity is different between polarizations)
- This seems to (amazingly) agree with the measurement (9.4% for X and 4.8% for Y)

# Implications

- We need both uniform  $l_s$  and small  $\Delta l_b$  but this **cannot** be achieved by surface corrections
- Using ordinary and extraordinary refractive indices,  $\Delta l_b$  can be written as
 
$$\Delta l_b = dn_o(n_o^2 - n_e^2)\theta^2 / (2n_e^2)$$
 For sapphire @ 1064 nm  
 $n_e = 1.747$   
 $n_o = 1.754$ 

where  $\theta$  is angle between c-axis and beam axis, [JGW-T0400030](#)  
 and  $d$  is ITM thickness (15cm)

Note that they are different in cryogenic temperatures and there might be additional birefringence due to stress or something
- If we require loss to be smaller than a threshold,

$$\Delta l_b < \sqrt{\lambda^2 \rho_{th} / (2\pi)^2}$$

$$\theta < \sqrt{\frac{2n_e^2 \sqrt{\lambda^2 \rho_{th} / (2\pi)^2}}{dn_o(n_o^2 - n_e^2)}}$$

For 10% (1000ppm) loss, these will be  
 54 nm (5.4 nm) and  
 0.41 deg (0.13 deg)

# Other Possibilities

- The shape of p-pol beams from ITMX and ITMY seems similar which implies common p-pol generation? [[klog #9329](#)]



- Beam height changes could create p-pol beam? (we have 1/300 inclination)
- Beam clipping creates p-pol beam somehow?

# Sapphire Axes

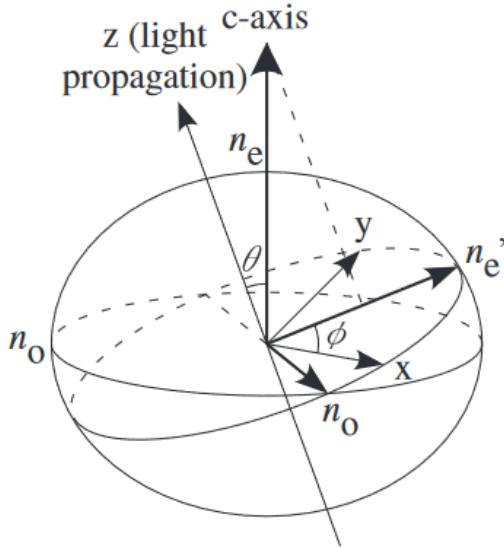

**Figure 1.** If the c-axis of the sapphire sample inclines by an angle  $\theta$  from the z-axis, the phase speed of light propagating along the z-axis depends on the direction of its electric field vector  $\mathbf{E}$ . The phase speed of a beam whose electric field is parallel to the projection of the c-axis onto the xy-plane, which inclines by an angle  $\phi$  from the x-axis, is  $c/n_e'$  and the phase speed of a beam whose electric field is perpendicular to the direction is  $c/n_o$ . The phase retardation between these two rays is given by Eq. 2.

Tokunari+, [JPCS 32, 432 \(2006\)](#)

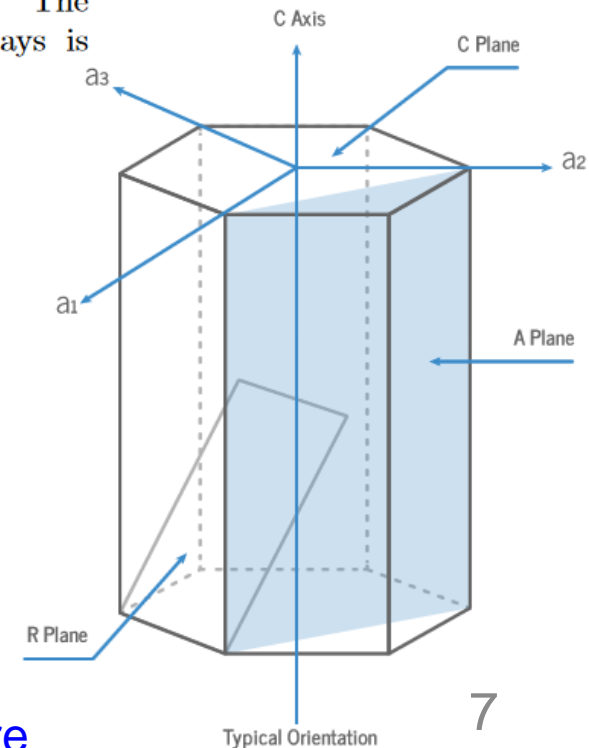

# Calculation Details

- Phase difference between o-axis and e'-axis

$$\alpha = 2\pi d(n_o - n_{e'})/\lambda$$

- p-pol power after ITM reflection

$$P_p/P_{in} = (1 - \cos^2 2\phi)(1 - \cos 2\alpha)/2$$

$$\leq (1 - \cos 2\alpha)/2$$

$$\simeq \alpha^2$$

Minimum s-pol power will be  $P_{in}*(1-\cos^2(2\phi))$

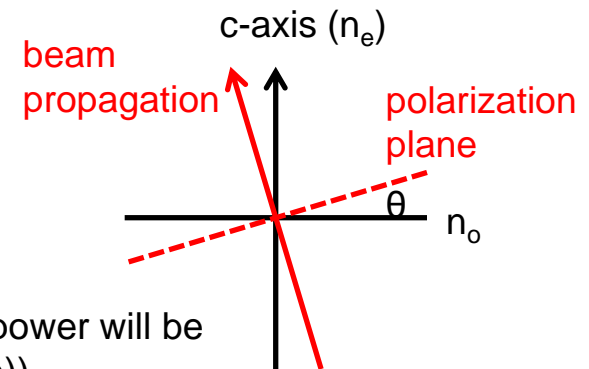

- Transmission wavefront error

$$d(n_o - n_{e'}) = 2(\underline{d(n_o + n_{e'})/2} - \underline{dn_{e'}})$$

Measured with circular polarization, and this is minimized by polishing

Not directly measured. RMS measured with s-pol shows small dependence on mirror orientation, and this suggests  $dn_{e'}$  map is similar to  $dn_o$  map in RMS

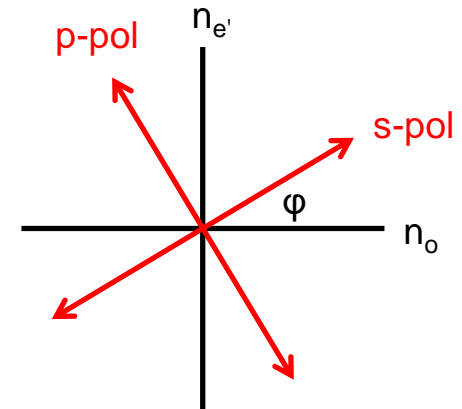

$\theta < 0.2$  deg ([JGW-T1809173](#))  
But  $\phi$  is totally unknown