

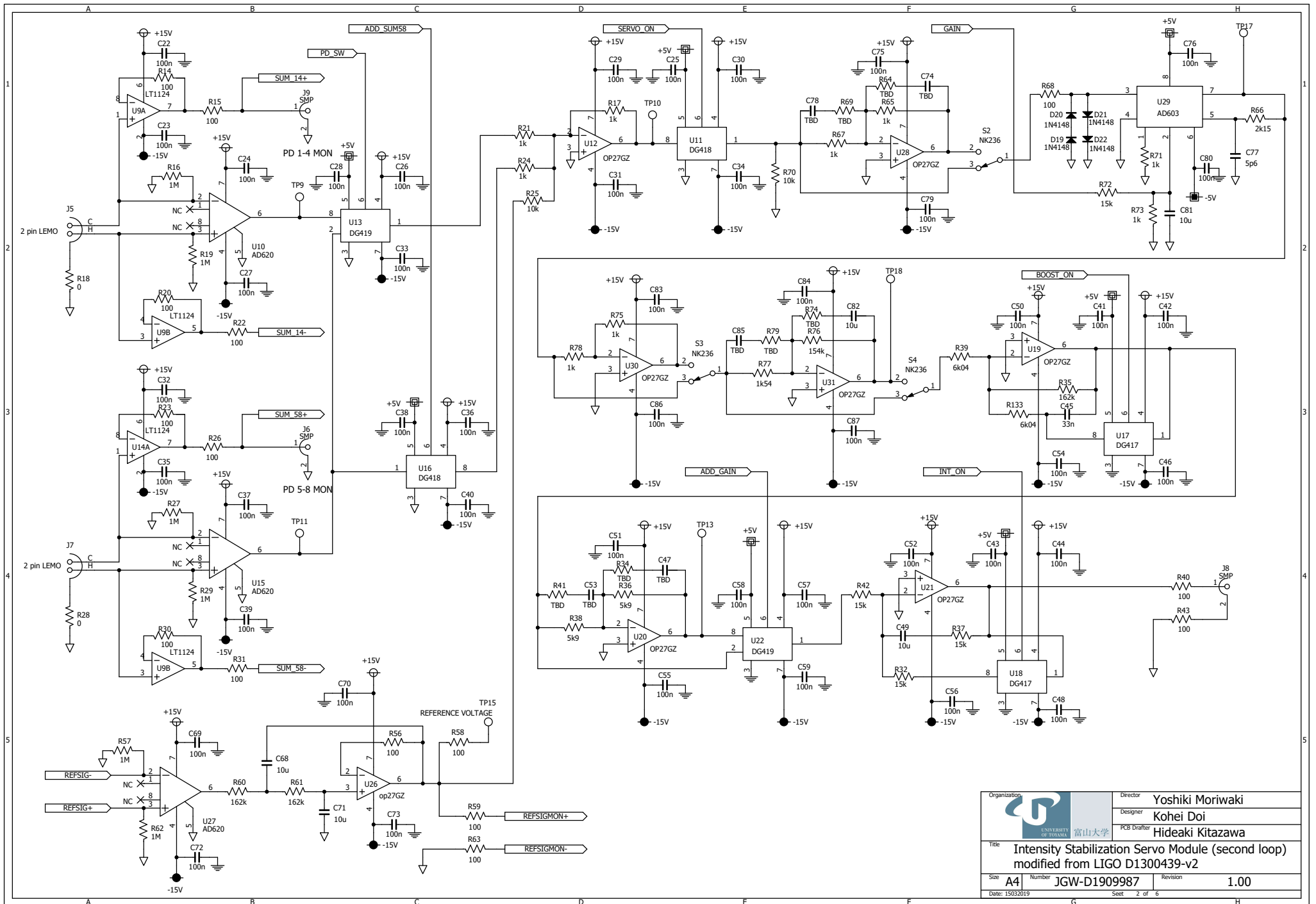



Organization	 富山大学	Director	Yoshiki Moriwaki
		Designer	Kohei Doi
		PCB Drafter	Hideaki Kitazawa
Title: Intensity Stabilization Servo Module (second loop) modified from LIGO D1300439-v2			
Size	A4	Number	JGW-D1909987
		Revision	1.00
Date: 15032019		Sheet	1 of 6



Organization	 富山大学	Director	Yoshiki Moriwaki
		Designer	Kohei Doi
		PCB Drafter	Hideaki Kitazawa
Title: Intensity Stabilization Servo Module (second loop) modified from LIGO D1300439-v2			
Size	A4	Number	JGW-D1909987
		Revision	1.00
Date:	15032019	Sheet	2 of 6

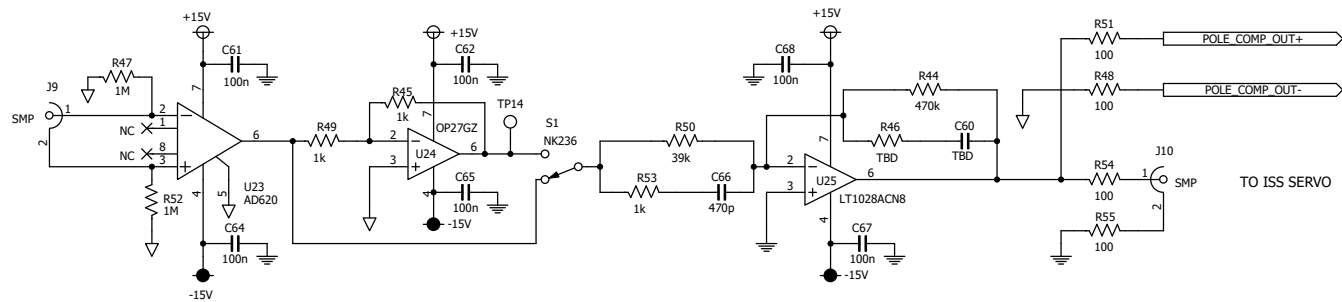

 富山大学 UNIVERSITY OF TOYAMA		Director Yoshiki Moriwaki
		Designer Kohei Doi
		PCB Drafter Hideaki Kitazawa
Title Intensity Stabilization Servo Module (second loop) modified from LIGO D1300439-v2		
Size A4	Number JGW-D1909987	Revision 1.00
Date: 15032019		Sheet 2 of 6