

Design Concept of Obelisk Post for POS

Yuta Michimura

Department of Physics, University of Tokyo

Steering Mirror for POS

- Steering mirror for POS and green beam for Yarm interfere with SR2 oplev beam
- Two options for solution:
 - Obelisk post with an attachment
 - Obelisk post with a hole
- See [JGW-L1909580](#) by Takeda-kun for details

Obelisk Post
[JGW-D1707299](#)

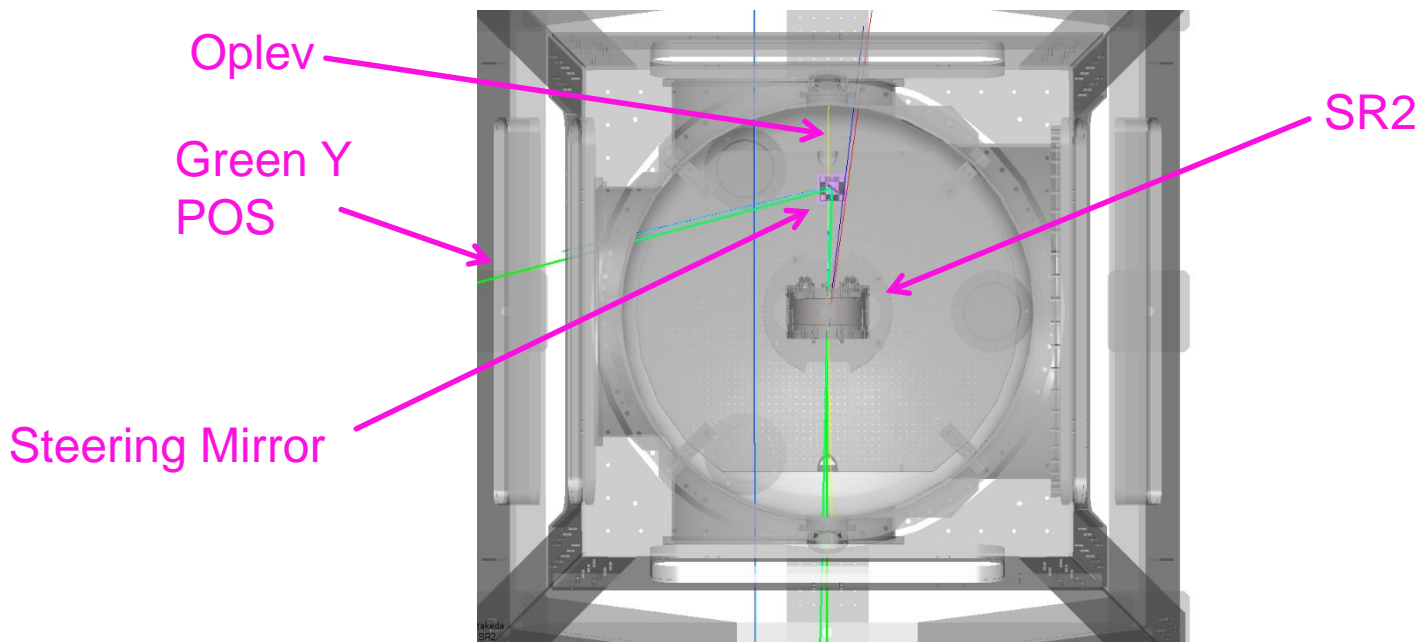

Obelisk Post with Attachment

- Put Obelisk away from the oplev beam

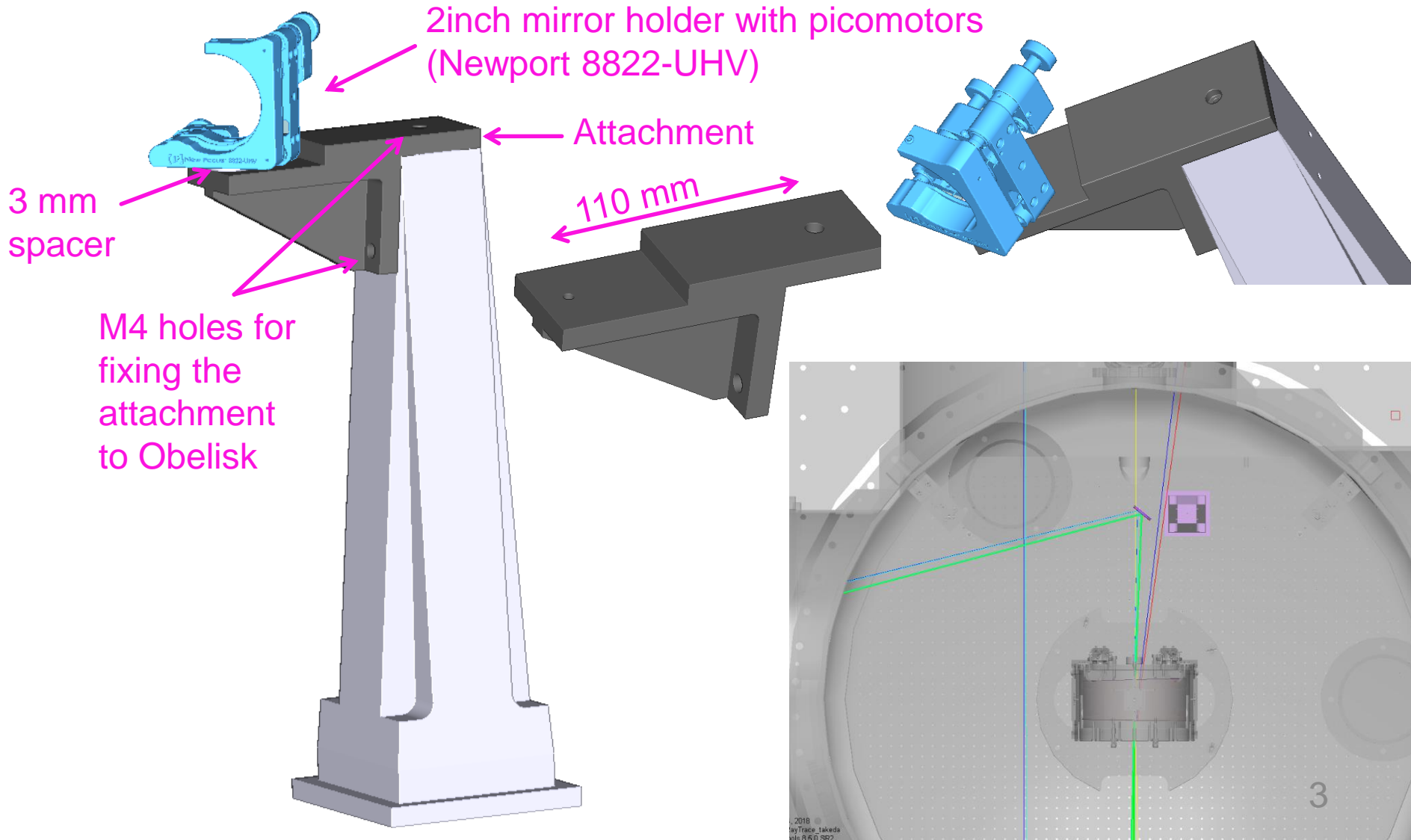

Obelisk Post with Hole

- Hole for oplev beam
- Checked that oplev beam goes through the hole with Lighttools

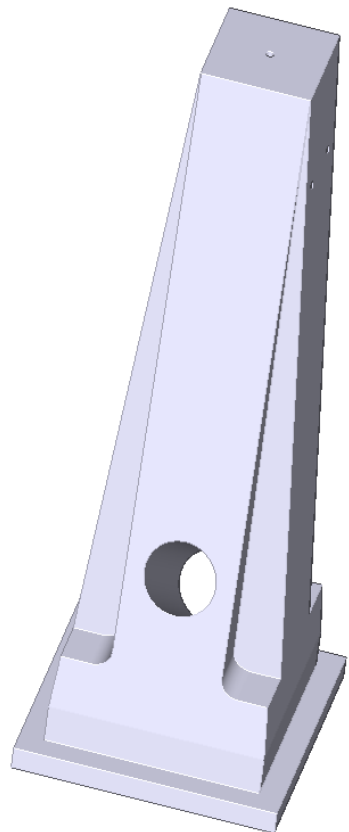

Hole
 ϕ 50 mm
38 deg

Oplev

Note:
Oplev beam radius is 0.1-1 mm and the size of the hole is enough. Larger hole is better for aligning the oplev beam.

