

Note:
- POXVAC omitted
- POYVAC omitted
- REFLVAC WFS not connected
- AS in-air table omitted
- Need to check the number of RF amp. distributor.

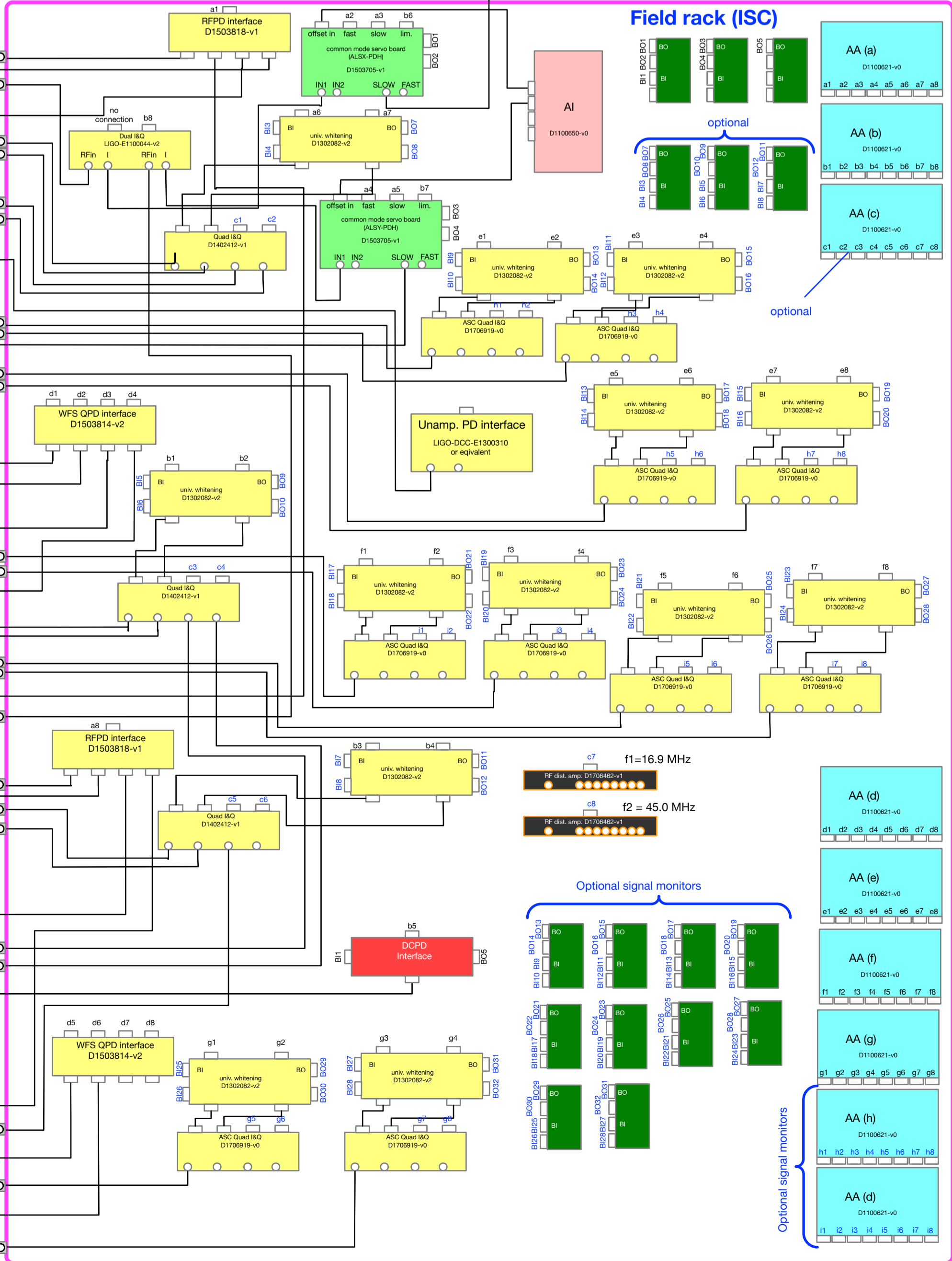
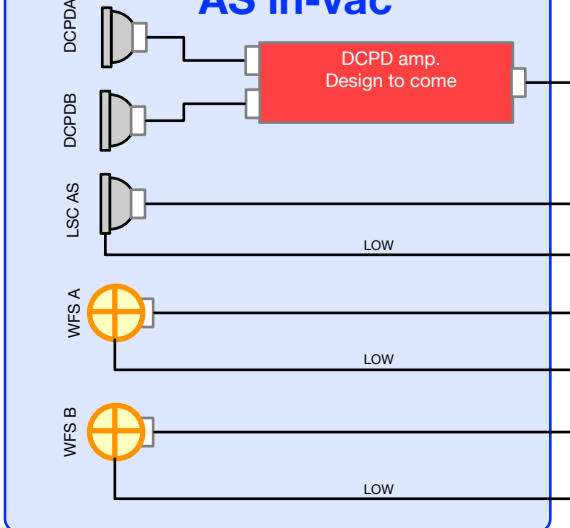
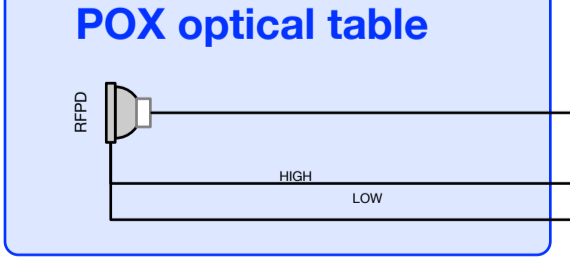
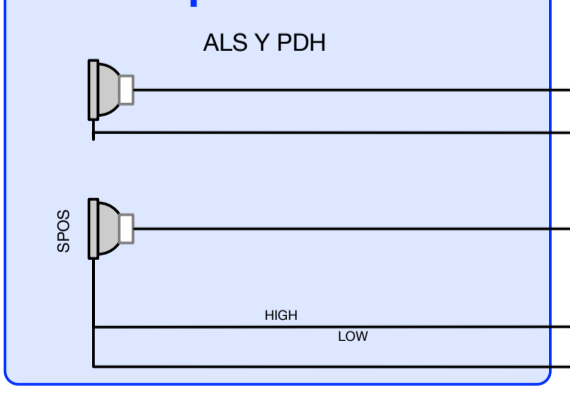
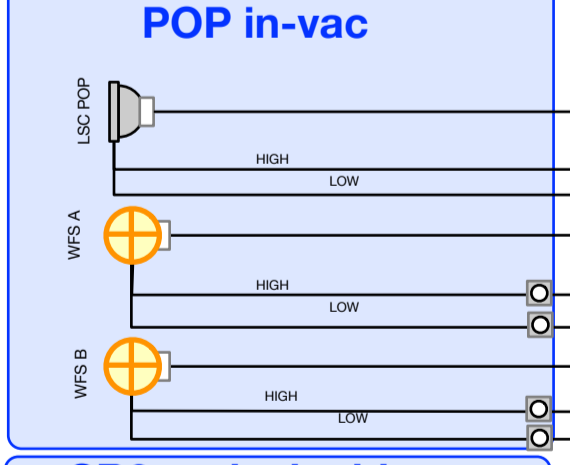
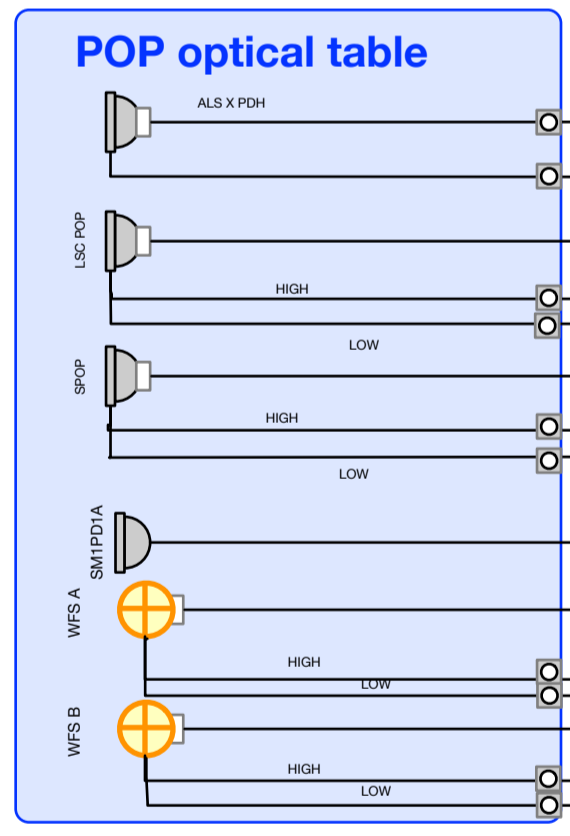
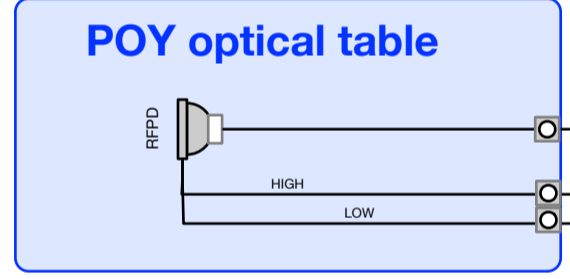
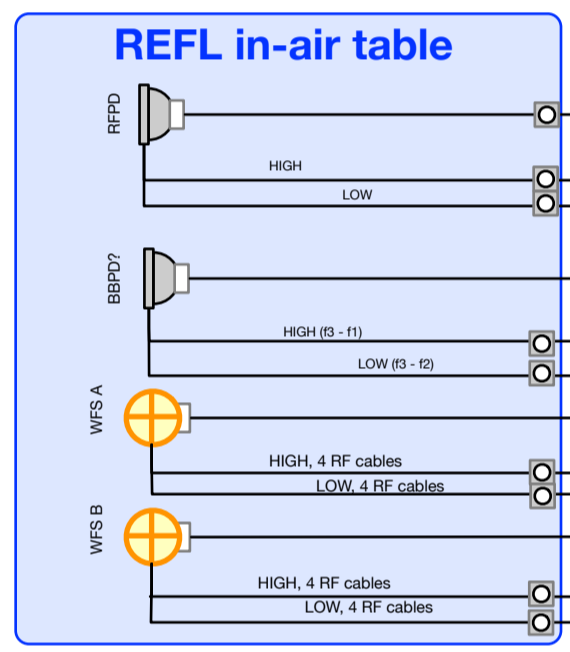
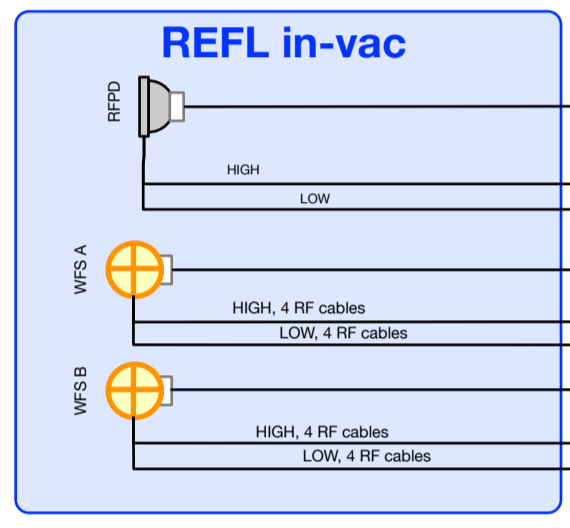

k1ioo

k1als0

- 4 ADCs
- 2 DACs
- 4 BIOS

k1als1

- 3 ADCs
- 0 DACs
- 6 BIOS

k1isc

- 2 ADCs
- 1 DAC
- 3 BIOS
or
- 4 ADCs
- 1 DAC
- 6 BIOS

k1asc0

- 4 ADCs
- 0 DAC
- 0 BIOS

k1asc1

- 2 ADCs
- 0 DAC
- 10 BIOS