

Procedure how to assemble the WAB

(Simon Zeidler)

General Notes

- Please read the section of this document you are going to work on today BEFORE you start the work and remember as much as possible as sometimes the work does not give you time to read this document.
- Clean the clean room everyday.
- Take the log. Leave them on k-log.
- Take many pictures. Leave them on k-log.
- Fix the suspension and cover it when you leave, and when you open the top window of the clean booth.
- When you moved tools, circuits, and so on, which belongs to the other subsystems, please make the log, and be sure to return it when finished. Especially, the information about where the circuits is necessary to be updated on the JGW doc DB.
- Take enough rest. If you feel tired, do not hesitate to go outside and take a rest.
- Wear proper items if necessary (safety gloves, helmets,,)
- You need two people who have crane licenses when you use the crane.
- If you got injured, please tell the responsibility person as soon as possible.
- When you work around/inside the vacuum chamber, wear clean inner wears and class-1 clean wear, which is the blue ones or ones with separated hood. And blow the air to remove your dust when you enter the clean room.
- Bring the clean suits outside for cleaning every Friday. After you brought them to the office, count the number of the suits w/ hood, suits w/o hood, hood, mask, gloves, and shoes.

*** Attention ***

In all steps of working, be advised to take special care of handling the (black-coated) baffle!

The special "solblack" coating is easily scratched or removed when touching it. Pay special attention to the most sensible parts of the baffle in terms of dumping scattered light:

- baffle edges
- The whole inner surface of the baffle

Drawings

To be found at the end of this document and in the JGW document server (Author: Yoshiyuki Obuchi).

List of Items

- BASE PLATE (1x)
- BASE PLATE SIDE + MIRROR (→ 2x)
- BASE PLATE STIFFENER (2x)
- SUSPENSION SUPPORT STRUCTURE PLATE (1x)
- SUSPENSION SUPPORT STRUCTURE BEAM STIFFENER (4x)
- SUSPENSION EQ STOP PLATE (2x)
- SUSPENSION SUPPORT STRUCTURE BEAM (2x)
- SUSPENSION EQ STOP ROD (8x)
- BAFFLE (1x)
- BAFFLE FLANGE (2x)
- BAFFLE FLANGE DISTANCE SPACER (4x)
- BAFFLE WING PLATE (4x)
- BAFFLE FLANGE RETAINER PIN (2x)
- BAFFLE FLANGE RETAINER PIN THREADED (2x)
- SUSPENSION DAMPER PLATE (4x)
- SUSPENSION PLATFORM PLATE STIFFENER (2x)
- SUSPENSION PLATFORM (1x)
- SUSPENSION YAW ADJUSTER BOSS BLOCK (1x)
- SUSPENSION Z-STAGE TOP PLATE (1x)
- SUSPENSION Z-STAGE BOTTOM PLATE (1x)
- SUSPENSION X-Y TRANSLATOR STAGE (1x)
- SUSPENSION BLADE SPRING ANCHOR BLOCK (1x)
- SUSPENSION BLADE SPRING (2x)
- SUSPENSION BLADE SPRING RETAINER PLATE (2x)
- SUSPENSION DAMPER T-BEAM (2x)
- SUSPENSION DAMPER PLATE SPRING (4x)
- SUSPENSION DAMPER PLATE SPRING RETAINER (4x)
- SUSPENSION DAMPER PLATE SPRING RETAINER THREADED (4x)
- SUSPENSION DAMPER MOUNT BRACKET (2x)
- SUSPENSION DAMPER MAGNET BASE PLATE (4x)

- SUSPENSION DAMPER MAGNET (> 8x)
- * JIG SHIPPING LOCK SHIELD PLATE (2x)
- * JIG SHIPPING LOCK T BRACKET (2x)
- * BAFFLE SHIPPING LOCK BRACKET A (2x)
- * JIG WIRE ASSEMBLY TOOL HANDLING PLATE (1x)
- * JIG WIRE ASSEMBLY TOOL BRACKET C (1x)
- * JIG WIRE ASSEMBLY TOOL BASE PLATE (1x)
- * JIG WIRE ASSEMBLY TOOL BRACKET B (1x)
- * SUSPENSION WIRE (4x)
- * SUSPENSION WIRE ANCHOR + MIRROR (→ 4x)
- * SUSPENSION WIRE ANCHOR Y-BRACKET (2x)
- * SUSPENSION WIRE ANCHOR RETAINER (2x)
- * BAFFLE WIRE ANCHOR WASHER (4x)
- Hex socket head cap screws:
 - M8 x 25 (1x)
 - M6 x 25 (4x)
 - ** M6 x 20 [small head] (26x)
 - M6 x 10 (2x)
 - ** M5 x 30 (16x)
 - M5 x 25 (4x)
 - M5 x 20 (8x)
 - M5 x 16 (44x)
 - M5 x 12 (12x)
 - M5 x 10 (8x)
 - ** M4 x 16 (2x)
 - M4 x 10 (8x)
 - M4 x 6 (8x)
 - ** M3 x 16 (6x)
 - M3 x 10 (8x)
 - M3 x 5 (10x)
- Special screws:
 - M5 x 15 (8x) [→ may be substituted by M5 x 16 screws]
 - FABBS6x30 (4x)
 - CBSTSR2.5-4 (8x)

- CBSTSR2.5-8 (8x)
- SFBJ2.5-6 (8x)
- SLXHC10-5-F20-MA8 (2x)
- * SUSPENSION Z-STAGE JACK SCREW (3x)

* New or revised parts after the first assembly test

** Need to count the overall number and set their specifications...

Detailed Description

1. Suspension Base (2 Persons)

- On the prepared table, first set the *{base plate}* in a 90° angle on its front-side* and screw the *{base plate sides}* (there are two of them, one is mirroring the other) on it from the bottom of the *{base plate}*
→ These *{base plate sides}* still have some extended screw-holes for a +Z vertical and tilt adjustment from an earlier version
- Set the *{base plate}* back to its nominal position and screw the *{base-plate-sides}* also from top.
- Screw the *{base plate stiffener}* to the *{base-plate-sides}*.

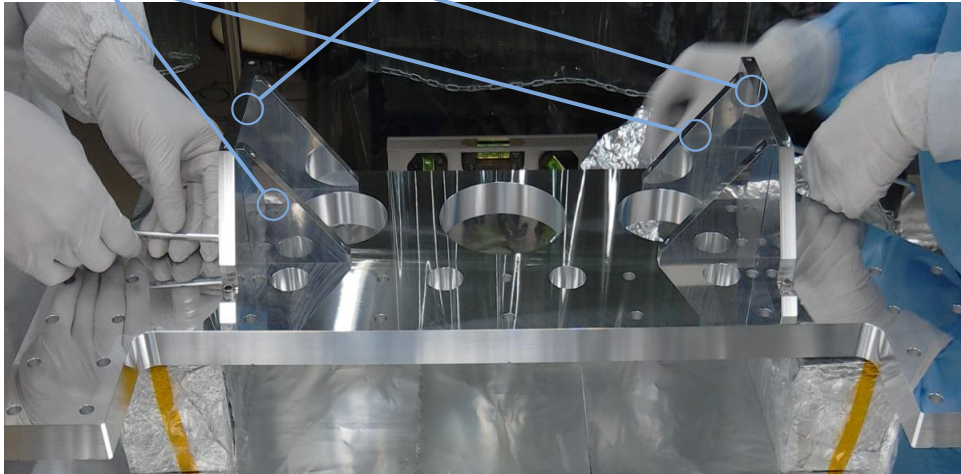

- Put the *{suspension support structure plate}* on top of the base-plate-sides and screw it tight.
- Put the *{suspension EQ stop plate}* and the *{suspension support structure beam stiffener}* on the *{suspension-support-structure-plate}*; screw the stiffeners and the stop-plate (from bottom of the structure-plate) but do not tighten the screws yet.

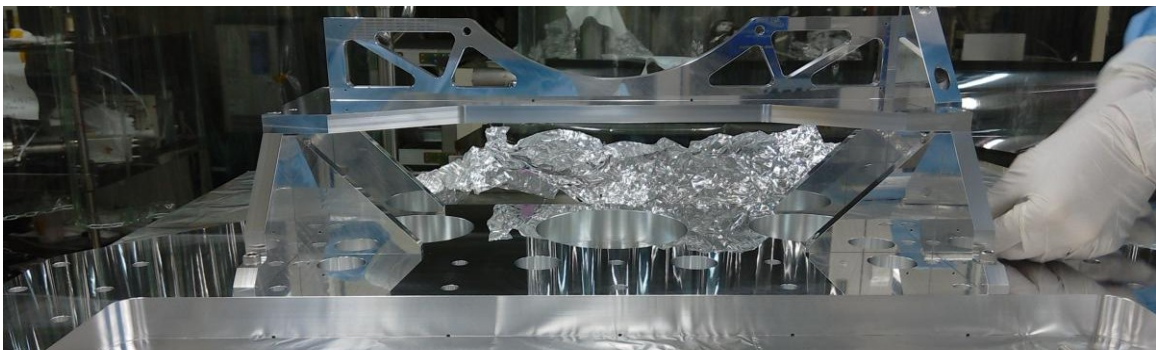

- Put the *{suspension support structure beams}* between the stiffener and the stop-plate and screw them together; start tighten all screws
- Set two pairs of *{suspension EQ stop rods}* on the stop-plate by first inserting a *[FABBS6x30]* into one rod, then inserting the open-end of the *[FABBS6x30]* through the respective holes in the stop-plate, and lastly screwing and tightening the other rod on that open-end.



* without limiting generality, “front-side” is meant to be the side facing the 3km duct in the WAB’s final destination in KAGRA (a.k.a. the smaller edge on the *{base plate}*)

2. Baffle Preparation (2 Persons)

- At first, the two halves of the *{baffle-flange set}* needs to be prepared:
 - Screw the *{baffle flange distance spacers}* on two of the *{baffle flange}* halves
 - Screw another half on the tips of the *{baffle flange distance spacers}*;
 - Mount the *{baffle wing plates}* on the flange-sides (two wings per half-baffle-flange set)
 - On the outer side of each wing, mount a *{baffle shipping lock bracket}*
- The *{baffle}* itself should lay on prepared stoppers (like wheel-stopper covered by Aluminum foil) on top of a plane-parallel table, so that it won't move
 - Set the stoppers so that a free space of >30cm is created around the center of the baffle
- Now, set one half of the *{baffle-flange sets}* sideways around the baffle center and the other half on the other side, so that the ends of both halves are facing each other (distance of the ends may be now ~5mm)
Proof the center position by measuring the distance of each baffle-flange to the ends of the baffle → the nominal distance should be 189mm! **Be careful not to touch/scratch the baffle!**
- Set the *{baffle flange retainer pin}* and the *{baffle flange retainer pin threaded}* on each side of the open end of the flanges and fix them with two *[M5x20 screws]*; Tighten the screws until a distance of ~3mm between the flanges is reached

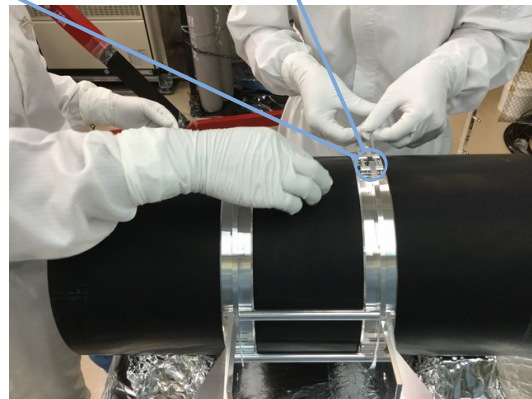
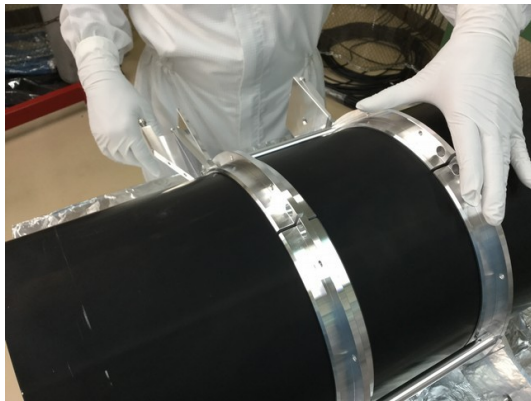

- Turn the baffle carefully around so that the other ends of the flanges are accessible
 - the best measure is to press the flanges together by setting the hands on the distance-spacers from both sides and to lift the baffle up
- Repeat the above mounting of the retainer and tighten the screws until a distance of ~3mm between the flanges is reached
Now, the flanges should be tightly fixed.
- Mount the *{suspension damper plates}* on each *{baffle wing plate}* with a *[Titanium screw*]*

3. Insert Baffle and Mount Suspension Roof (2 Persons)

- Set the baffle carefully inside the (half) assembled suspension structure so that the {EQ stop rods} keep it in position (if properly set, the rods may be even not necessary for that)

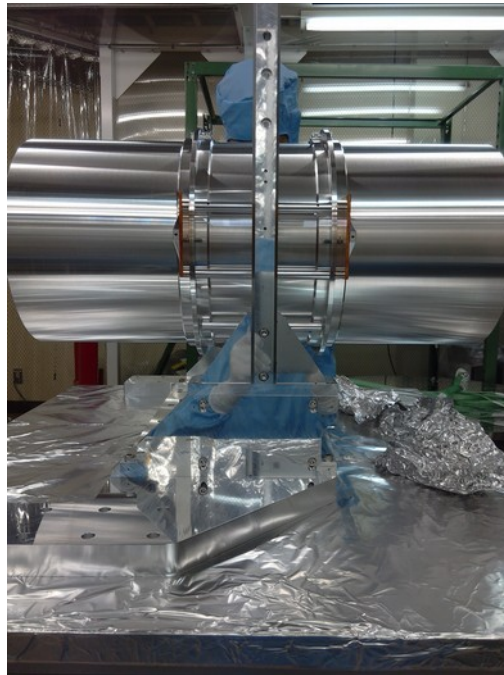

- Set the upper {suspension EQ stop-plate} in between the two {suspension support structure beams} and screw it to them (do not tighten yet!)
- Mount the two {suspension platform plate stiffeners} on the upper {suspension EQ stop-plate} by using the respective screw holes on the stop-plate [M4?]
- Set the {suspension platform} on the top of the {suspension support structure beams} and the {suspension platform plate stiffeners} alike; Screw them tight

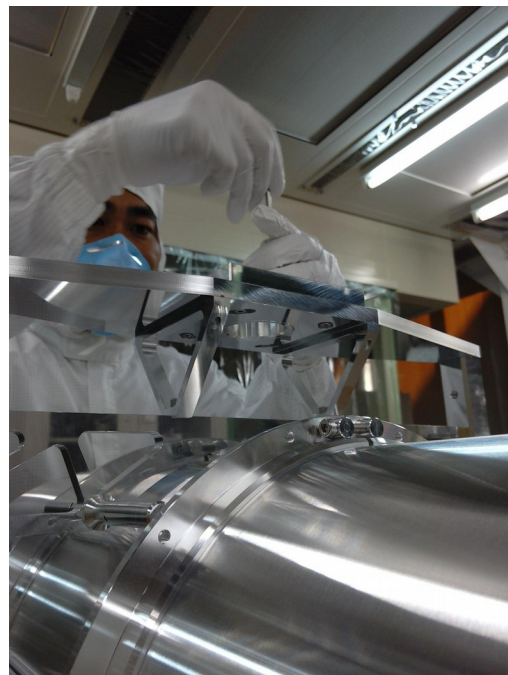
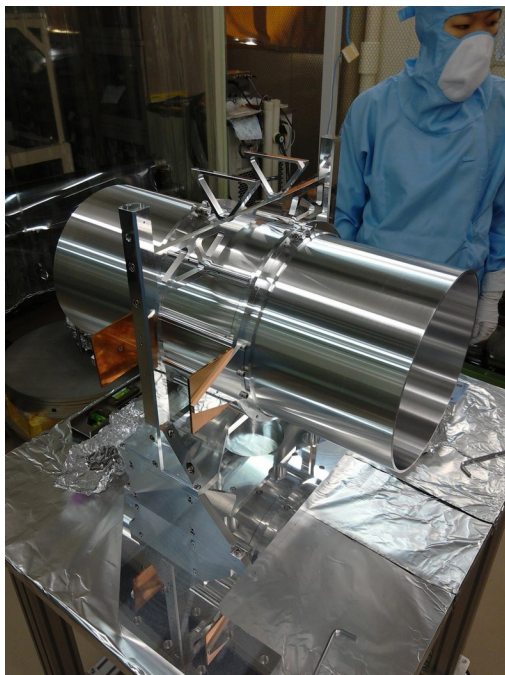

- Set the *{suspension yaw adjuster boss block}* onto the *{suspension platform}* (screw it from the bottom of the platform)

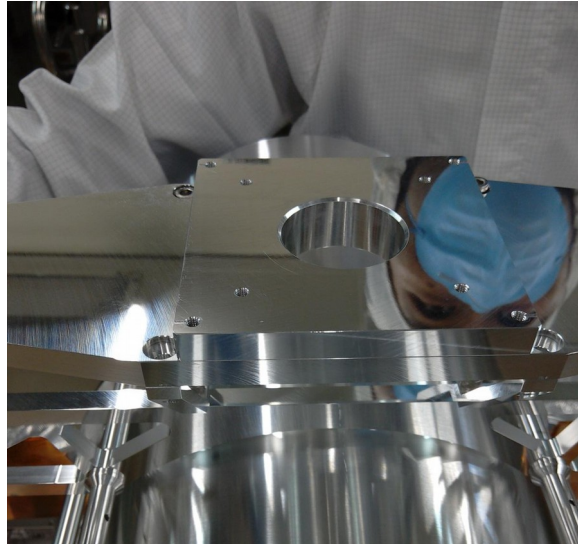

- Mount the *{suspension Z-stage bottom plate}* on the respective *{top plate}* with three *[jack screws]* on the *{suspension yaw adjuster boss block}* with *[M4 screws]*
- Mount the (degreased!*) *{X-Y translator stage}* on the *{Z-translator stage}* with *[M4 screws]*

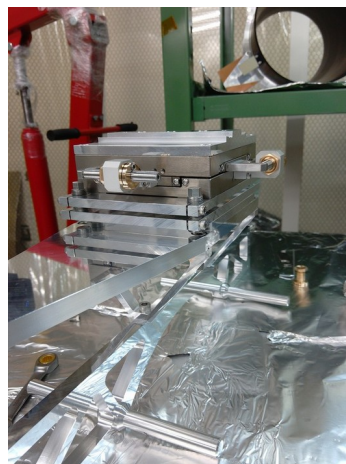

- Mount the *{suspension blade spring anchor block}* on the *{X-Y translator stage}*

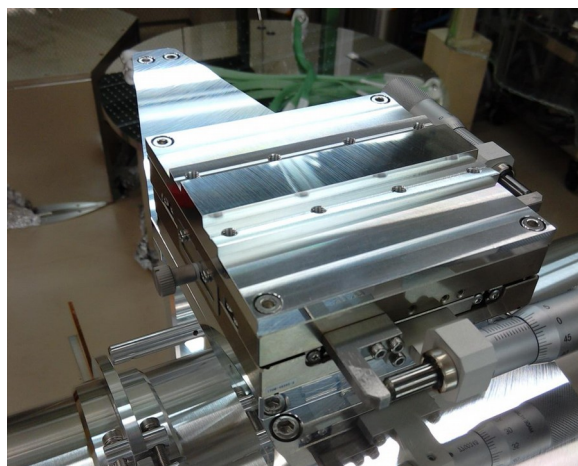

* For degrease a XY-translator stage, see [here](#)

4. Damper (1 Person)

The two damper suspensions have to be assembled outside the WAB suspension first. After that, they can be placed on their positions on the *{suspension support structure beams}*.

The actual assembly of the dampers is relatively simple and straight forward (please refer also to the *{suspension damper assembly}* document):

- Take the *{suspension damper mount bracket}* and screw a *{suspension damper plate spring}* on its bottom side (use *[CBSTSR ultra low head cap screws]* for that)
- Do the same for the *{suspension damper T-beam}* only that the spring-plate needs to be screwed on its top
- Screw the ends of each spring-plate (on the bracket and T-beam) to its respective counterpart; use the *{suspension damper plate spring retainers}* for that by setting them so that the spring-plates are in between them;
Between each end of the spring-plate, set a spacer in form of a *{suspension damper plate retainer}* (for the cooling-test, we are using simple nuts for that purpose) preventing the spring-plates touching each other.
Note: there are two different retainers, one is **threaded** (and bigger) and the other one thinner and non-threaded. The threaded one is to be set on the bottom and the non-threaded one on top and as spacer!
Also here, use the *[CBSTSR ultra low head cap screws]!*
- Screw the two *{suspension damper magnet base plates}* on each side of the “T” with the *[SFBJ flat head screws]*
- Set the magnets to their supposed places on the *{suspension damper magnet base plates}*

After assembly of the dampers, screw them on the *{suspension support structure beams}*.

Note: in the picture below, the magnet-damper is set without the baffle installed for a better view. Also, the magnets are different in the actual cases.

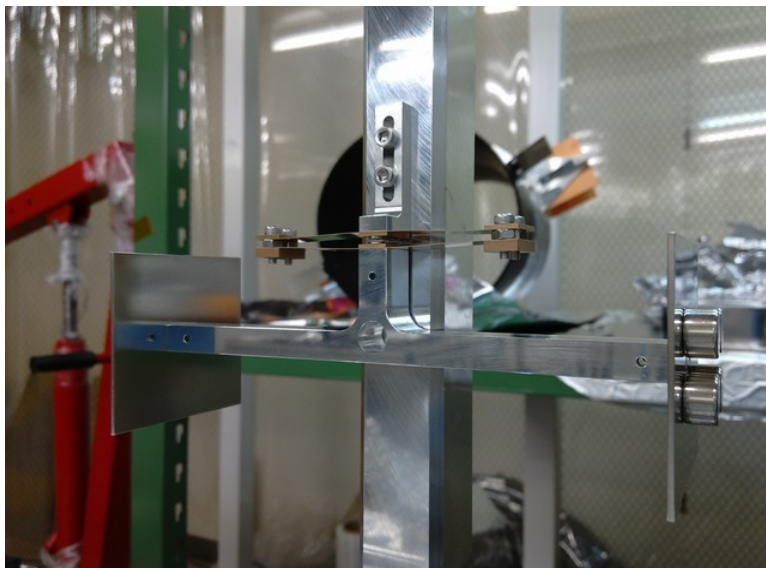

In case the baffle is already suspended, mounting the dampers is a bit more tricky. Try to place the damper from below the baffle wings and do not touch the wires!

5. Hanging (2-3 Persons)

- On the *{suspension blade spring anchor block}*, mount the *{suspension blade springs}* (use *[M5x15 screws]*)
- Set up the winding-jig by taking the *{wire-jig base plate}* and mount the *{suspension wire anchor*}* clamps on the bottom and the *{suspension wire anchor Y-bracket}* on top of it → triangular shape
(the wire grooves of the bottom part should show to the top; those of the Y-bracket should show to the bottom)

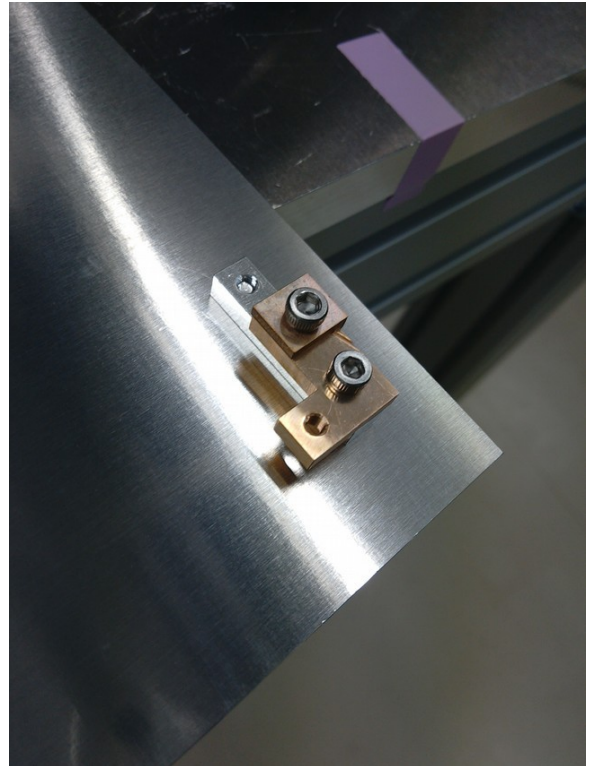
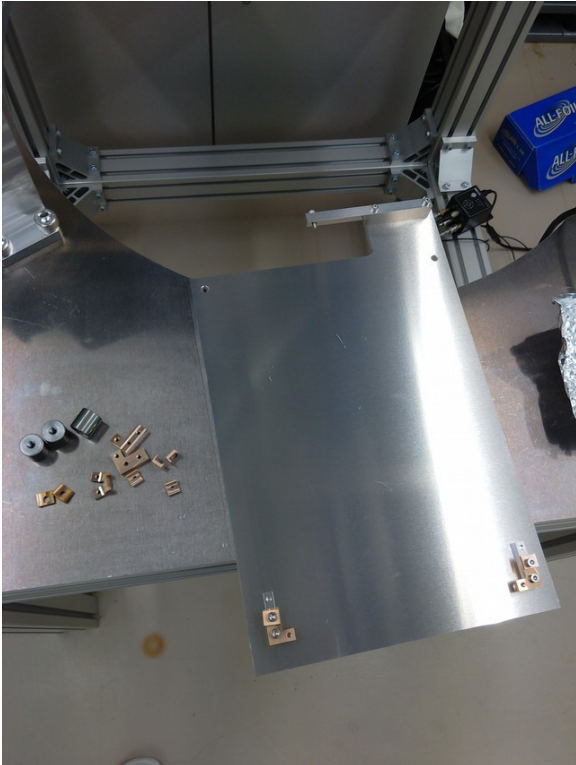

- Cut a *{steel-wire}* into two pieces of ca. 30 cm length and set the end of one of those pieces into the groove of one of the bottom wire-clamps; fix it there with the *{suspension wire anchor retainer}* and a *[M4x8 screw]*
- Set the other end into one of the grooves of the Y-bracket (observe from the bottom side as the groove is upside down) and fix it with another *{suspension wire anchor retainer}* (*[M4x8 screw]*) (Note: hold the wire tight before fixing it)

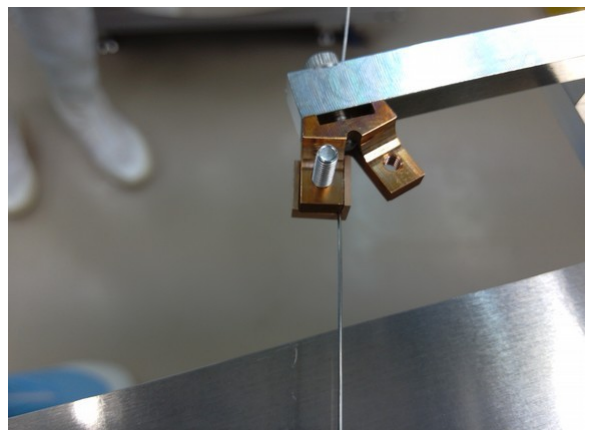
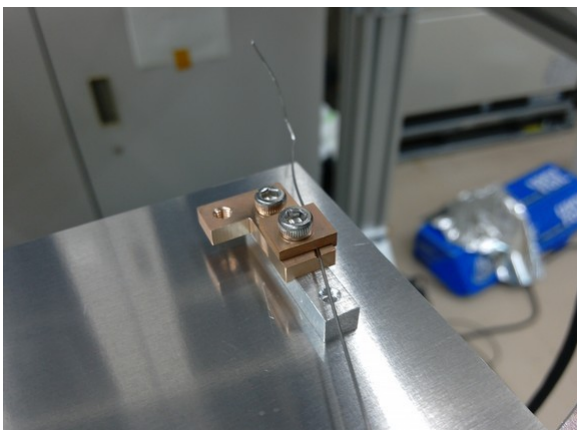

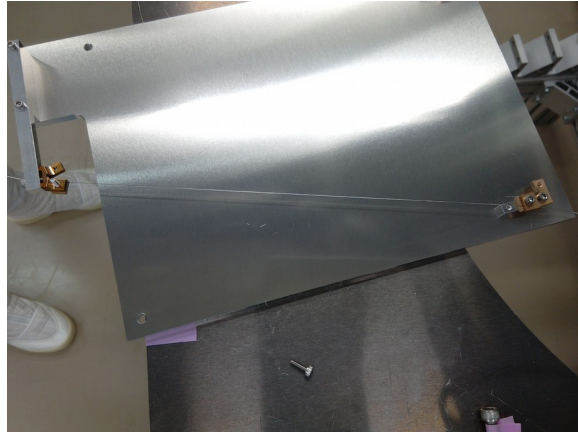

- Do the same for the other side
- For additional security, wind the ends of the wires around the head of the fixing screws on the retainers

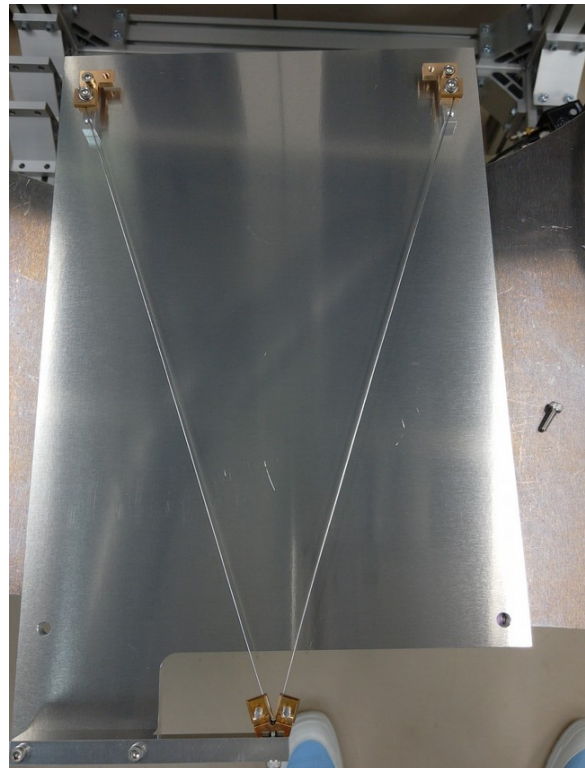
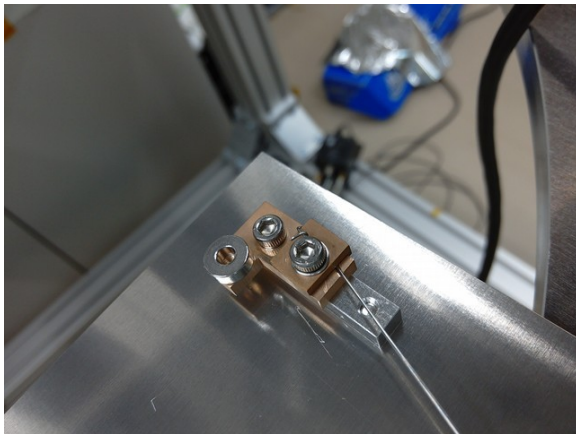

- The result is a triangular shaped setup of two wires clamped together
- Put a 3mm** thick washer on the open screw hole of each of the bottom wire-clamp
- Put the *{wire assembly support shield}* on the fixed wire assembly so that the screw holes are fitting with the top M4 screws and the screw holes of the bottom wire-anchors
- Screw them together by using nuts and *[M4x8 screws]*



- Unscrew the anchors from the *{wire-jig base plate}* and take the *{wire assembly support shield}* with the now mounted wire assembly to the WAB (use the two holes in the shield for holding it)
- Mount the *{suspension wire anchor Y-bracket}* to the end point of the *{suspension blade spring}* (use the *[M4 screw]*) and the bottom anchors to the two *{baffle wing plates}*; unscrew the *{wire assembly support shield}* from the Wire-Anchors
Note: it is necessary to lift the whole baffle structure for that or to push the wing blades down until the hanging is finished! → special clamps for the blades or another person is needed!
- Prepare the second wire assembly with the same steps as above and mount it to the other side of the WAB
- Release the baffle or the *{suspension blade springs}*, respectively
- In order to keep the wires protected during transport or installation into the test-mass chamber, mount a the triangular shaped *{protection shield}* on each site of the WAB (see bottom picture)

* This is part is not included in the attached drawings

** 3mm or 2.5mm

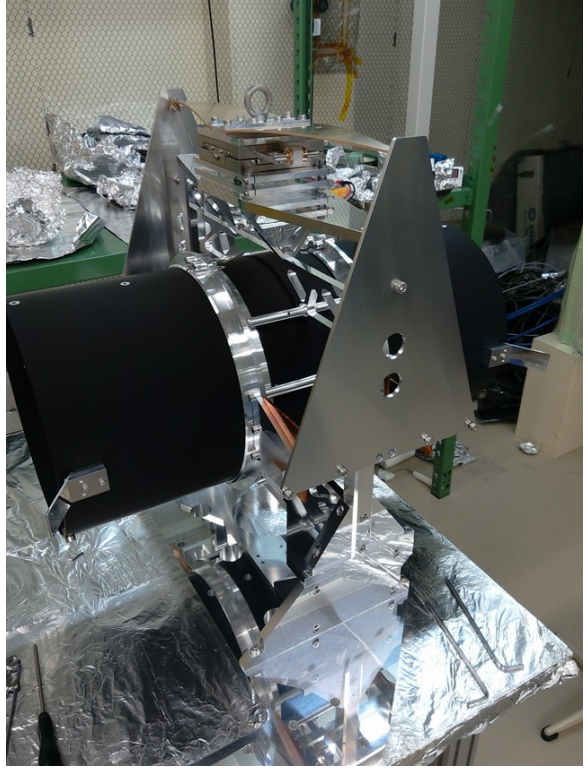
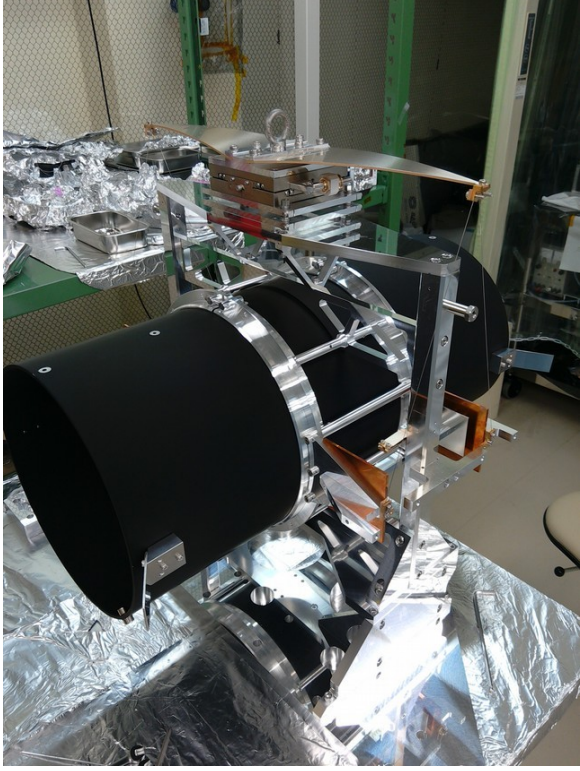

6. Adjustment

Setting-up the adjustment of the WAB is one of the most crucial things as a misaligned baffle may reduce significantly the purpose of the WAB.

However, not all of the degrees of freedom (DoF) are equally crucial to the influence of back-scattering or diffraction of the main-beam in KAGRA.

The most important DoF are the “Yaw”, the X- and the Z-direction (Y marks the direction of the main-beam [[referring to the WAB cooling test in IYC](#)], Z is vertical).

Note:

- If we stick to Obuchi-san’s new design of how to hang the baffle, the “Roll” and especially the “Pitch” DoF may be not significantly misaligned as the length of each wire cannot vary as much as it would before.
- In the current design (if the wires are all of the same length), the X and Y position of the baffle is not a real DoF. Instead, there are a X- and Y-pendulum DoF because of the stiffness of the wires.

Alignment of the baffle should be finished if the center of the baffle is 26.8cm (considering 27cm as working-height in the cryostat @20K) above the ground with the EQ-stopper in equal distance to the flanges around the baffle and the baffle itself.

An Offset in the Y-pendulum-, Pitch-, Roll-, and Z DoF can be set with the three-head adjustment stage on the *{suspension yaw adjuster boss block}* which itself controls the offset in Yaw.

The X-Y translator stage controls the X- and Y-position’s offset of the baffle itself.

How to Adjust

1. Set up a laser leveler on one side of the open chamber to measure the Pitch
 - a) Use the baffle wing plates for these measurement!
2. Set up a laser leveler inside the chamber (center-line along the main-beam direction) to measure Yaw and Roll
 - a) Also here, use the baffle wing plates for the Roll-measurement*
 - b) For Yaw it is important to know the actual center-line (or main-beam line) inside the chamber!
Once known, the laser leveler needs to be adjusted to this line
 - c) Use the baffle-flange lids for the Yaw-measurement (laser-line needs to go through both, then the maximum angular error is limited to 0.5° [assuming the laser-leveler beam is $\sim 1.5\text{mm}$ in diameter])

* One issue found is that the correct adjustment of the laser-leveler inside the chamber is a bit difficult without a good tripod. Especially setting it even to the chamber ground. That makes it difficult to measure the Roll precisely (\rightarrow need a smaller tripod for measurements inside the chamber!).
Alternative: measure the height of the baffle wing plates above the ground with a vertical ruler and compare both sides.

7. Drawings

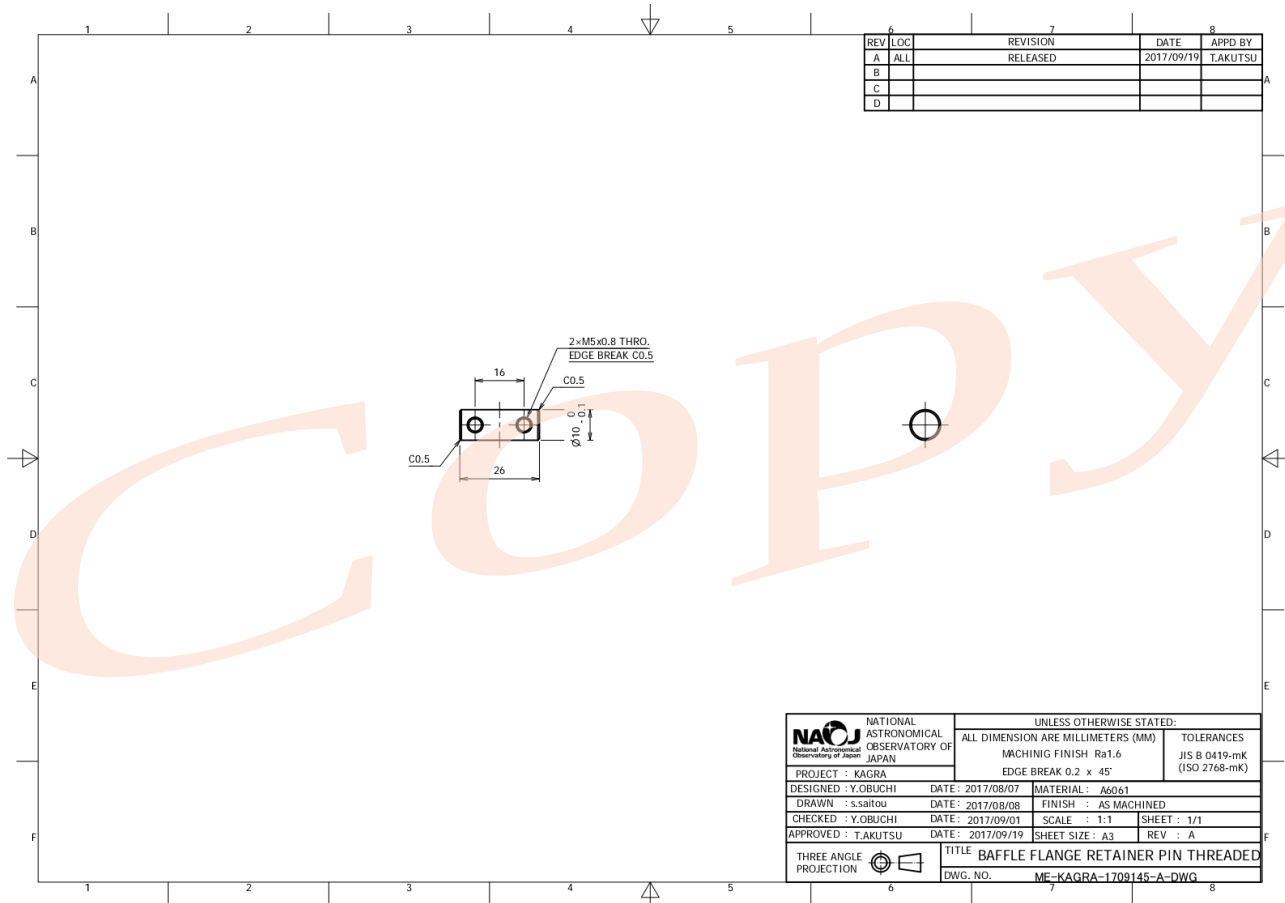
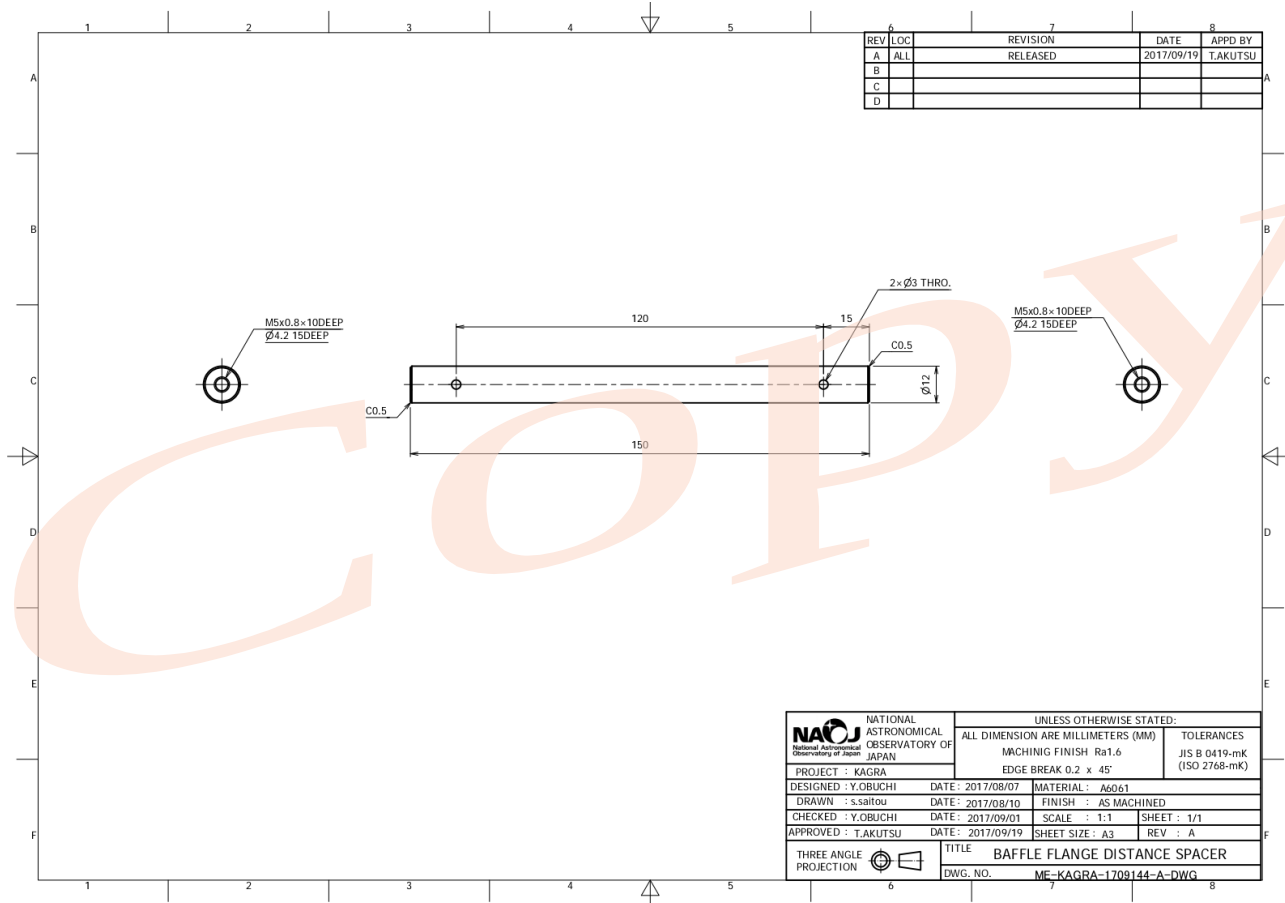

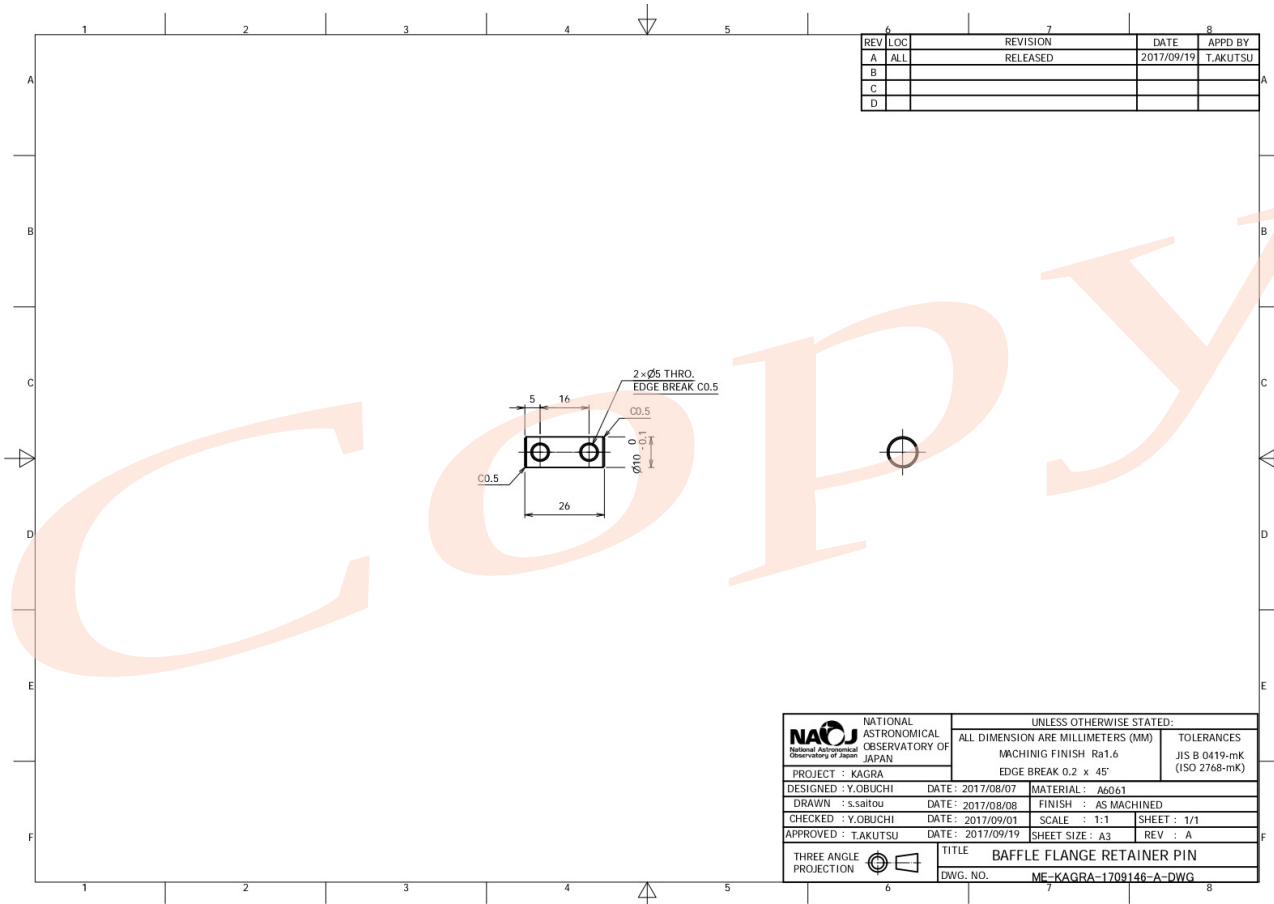

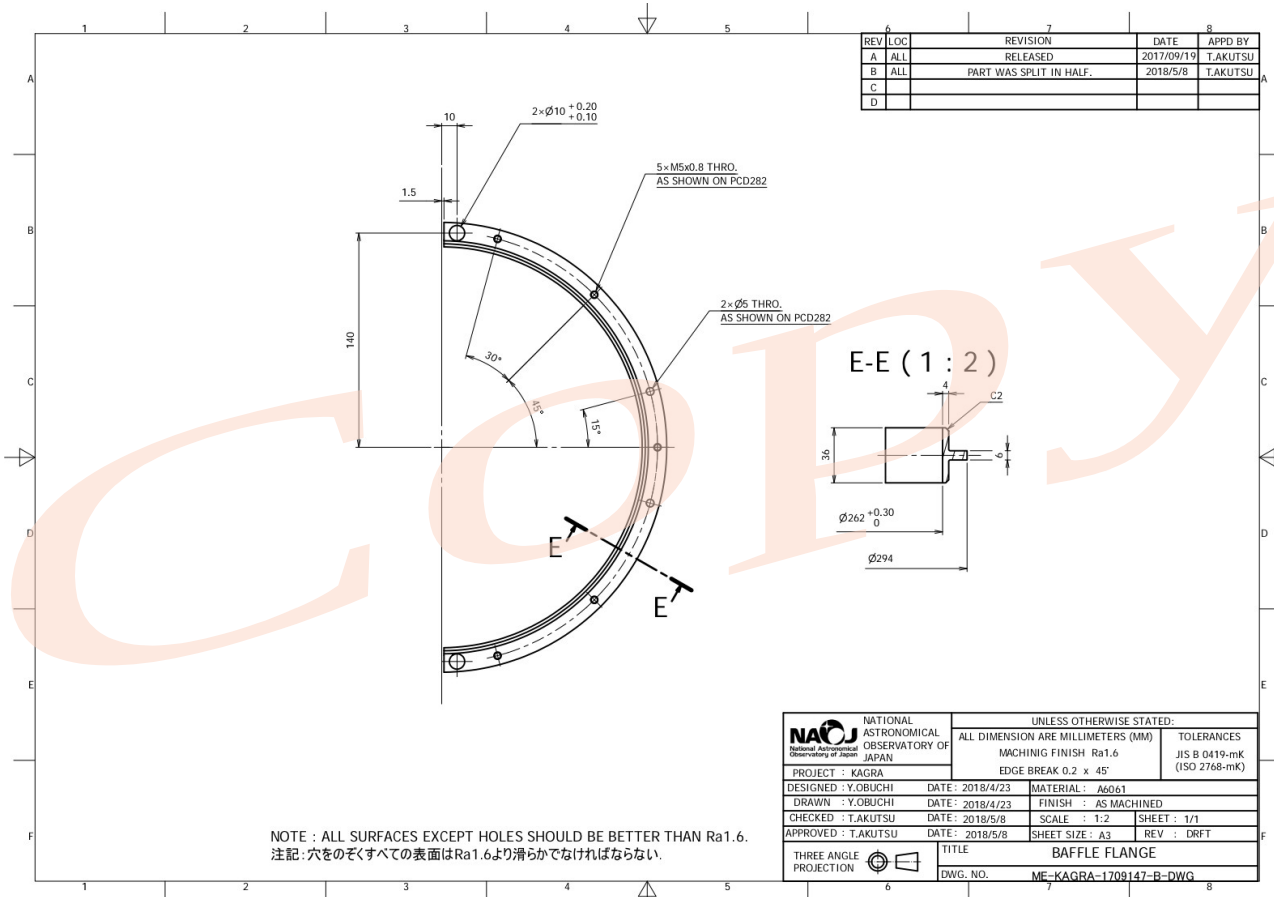

NATIONAL ASTRONOMICAL OBSERVATORY OF JAPAN		UNLESS OTHERWISE STATED:	
PROJECT : KAGRA		ALL DIMENSION ARE MILLIMETERS (MM)	TOLERANCES
DESIGNED : Y.OBUCHI DATE : 2017/08/07		MACHINING FINISH Ra1.6	JIS B 0419-mK (ISO 2768-mK)
DRAWN : s.saitou DATE : 2017/08/08		EDGE BREAK 0.2 x 45°	
CHECKED : Y.OBUCHI DATE : 2017/09/01		FINISH : AS MACHINED	
APPROVED : TAKUTSU DATE : 2017/09/19		SCALE : 1:1	SHEET : 1/1
THREE ANGLE PROJECTION		TITLE	BAFFLE FLANGE RETAINER PIN
		DWG. NO.	ME-KAGRA-1709146-A-DWG



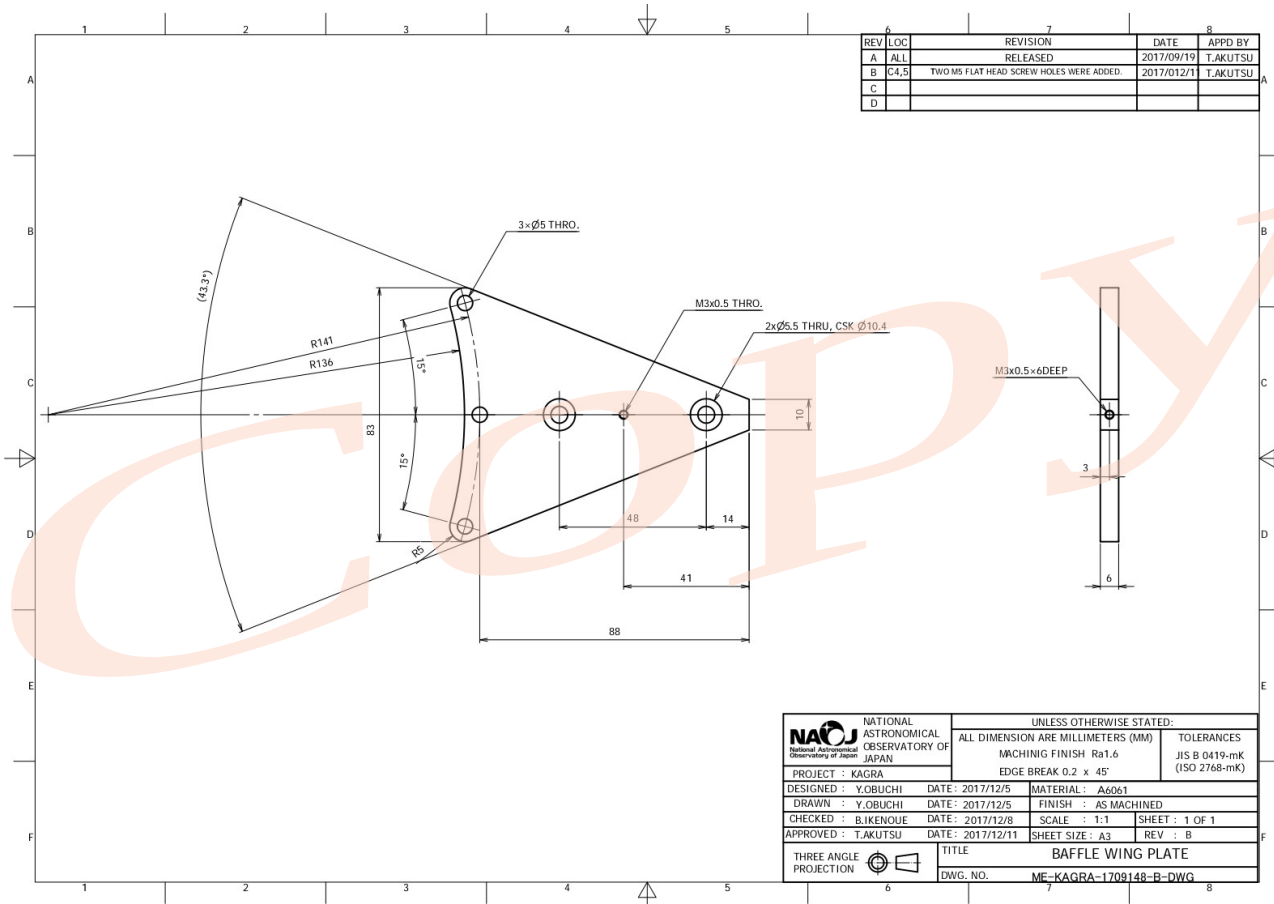

NATIONAL ASTRONOMICAL OBSERVATORY OF JAPAN		UNLESS OTHERWISE STATED:	
PROJECT : KAGRA		ALL DIMENSION ARE MILLIMETERS (MM)	TOLERANCES
DESIGNED : Y.OBUCHI DATE : 2018/4/23		MACHINING FINISH Ra1.6	JIS B 0419-mK (ISO 2768-mK)
DRAWN : Y.OBUCHI DATE : 2018/4/23		EDGE BREAK 0.2 x 45°	
CHECKED : T.KAUTSU DATE : 2018/5/8		FINISH : AS MACHINED	
APPROVED : TAKUTSU DATE : 2018/5/8		SCALE : 1:2	SHEET : 1/1
THREE ANGLE PROJECTION		TITLE	BAFFLE FLANGE
		DWG. NO.	ME-KAGRA-1709147-R-DWG

NOTE : ALL SURFACES EXCEPT HOLES SHOULD BE BETTER THAN Ra1.6.
 注記 : 穴をのぞくすべての表面はRa1.6より滑らかでなければならない。



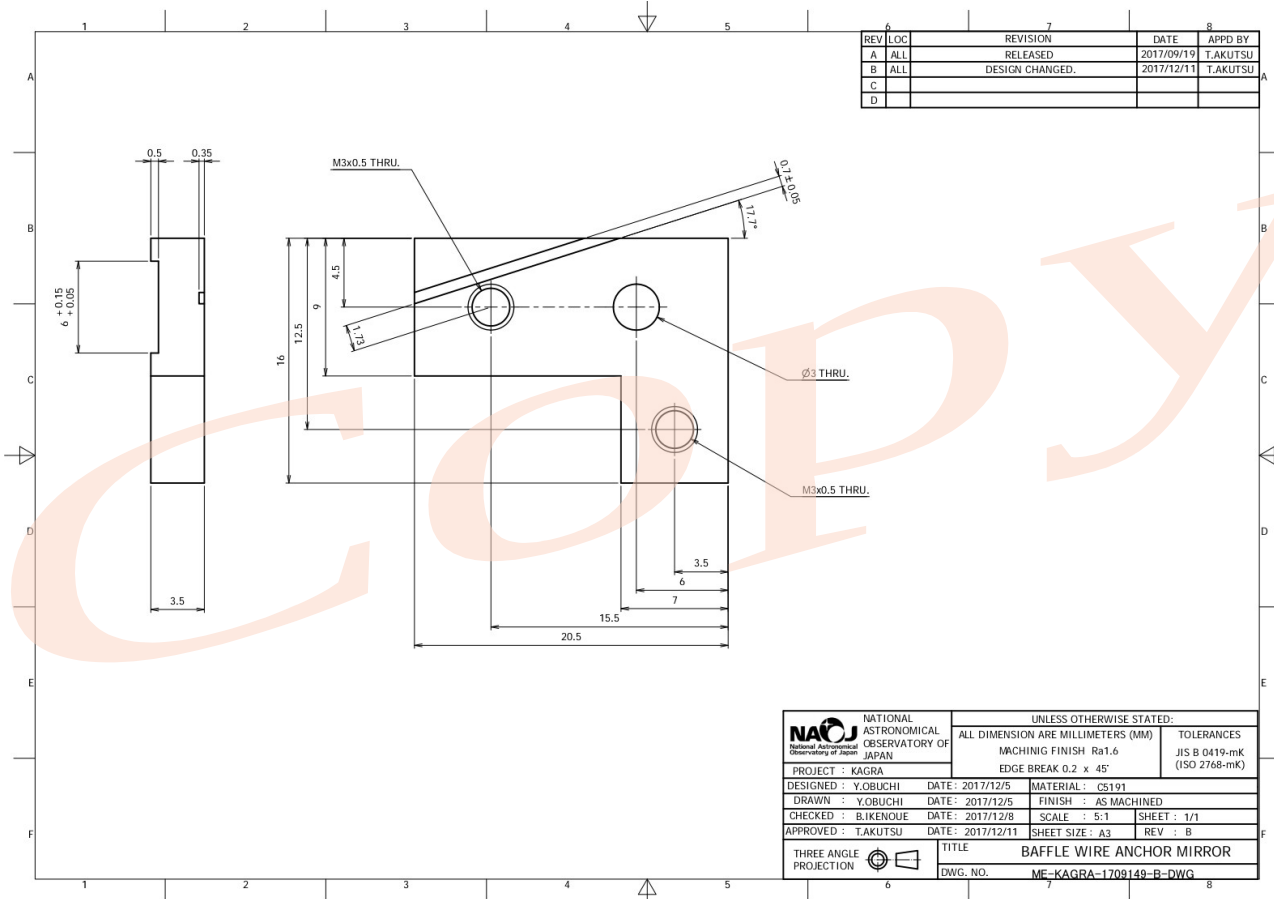

 NATIONAL ASTRONOMICAL OBSERVATORY OF JAPAN <small>National Astronomical Observatory of Japan</small>	UNLESS OTHERWISE STATED:	
	ALL DIMENSION ARE MILLIMETERS (MM)	TOLERANCES JIS B 0419-mK (ISO 2768-mK)
PROJECT : KAGRA	DATE : 2017/12/5	MATERIAL : A6061
DESIGNED : Y.OBUCHI	DATE : 2017/12/5	FINISH : AS MACHINED
DRAWN : Y.OBUCHI	DATE : 2017/12/8	SCALE : 1:1
CHECKED : B.IKENOUE	DATE : 2017/12/11	SHEET SIZE : A3
APPROVED : T.AKUTSU	DATE : 2017/12/11	REV : B
THREE ANGLE PROJECTION	TITLE : BAFFLE WING PLATE	
	DWG. NO.	ME-KAGRA-1709148-B-DWG



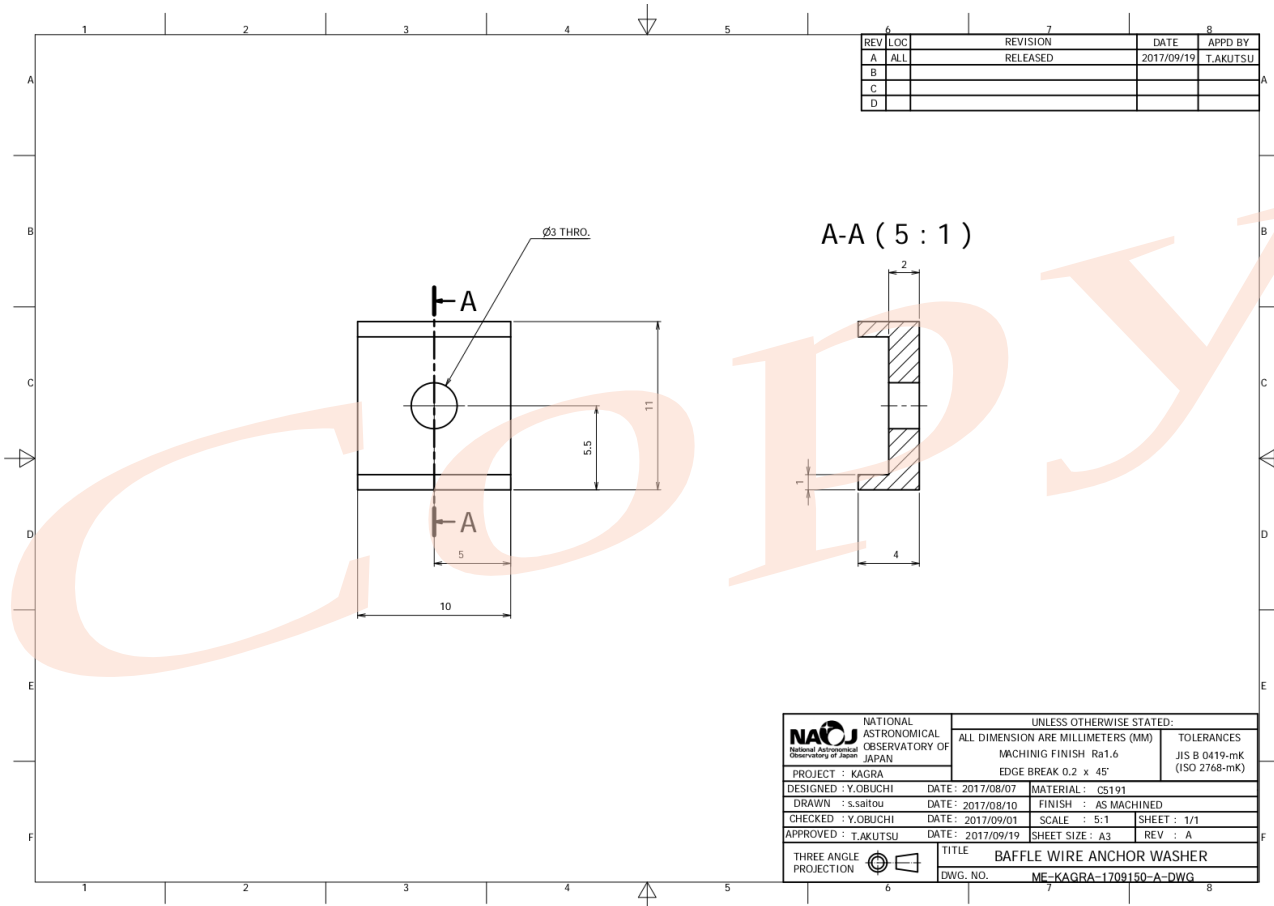

 NATIONAL ASTRONOMICAL OBSERVATORY OF JAPAN <small>National Astronomical Observatory of Japan</small>	UNLESS OTHERWISE STATED:	
	ALL DIMENSION ARE MILLIMETERS (MM)	TOLERANCES JIS B 0419-mK (ISO 2768-mK)
PROJECT : KAGRA	DATE : 2017/12/5	MATERIAL : C5191
DESIGNED : Y.OBUCHI	DATE : 2017/12/5	FINISH : AS MACHINED
DRAWN : Y.OBUCHI	DATE : 2017/12/8	SCALE : 5:1
CHECKED : B.IKENOUE	DATE : 2017/12/11	SHEET SIZE : A3
APPROVED : T.AKUTSU	DATE : 2017/12/11	REV : B
THREE ANGLE PROJECTION	TITLE : BAFFLE WIRE ANCHOR MIRROR	
	DWG. NO.	ME-KAGRA-1709149-R-DWG

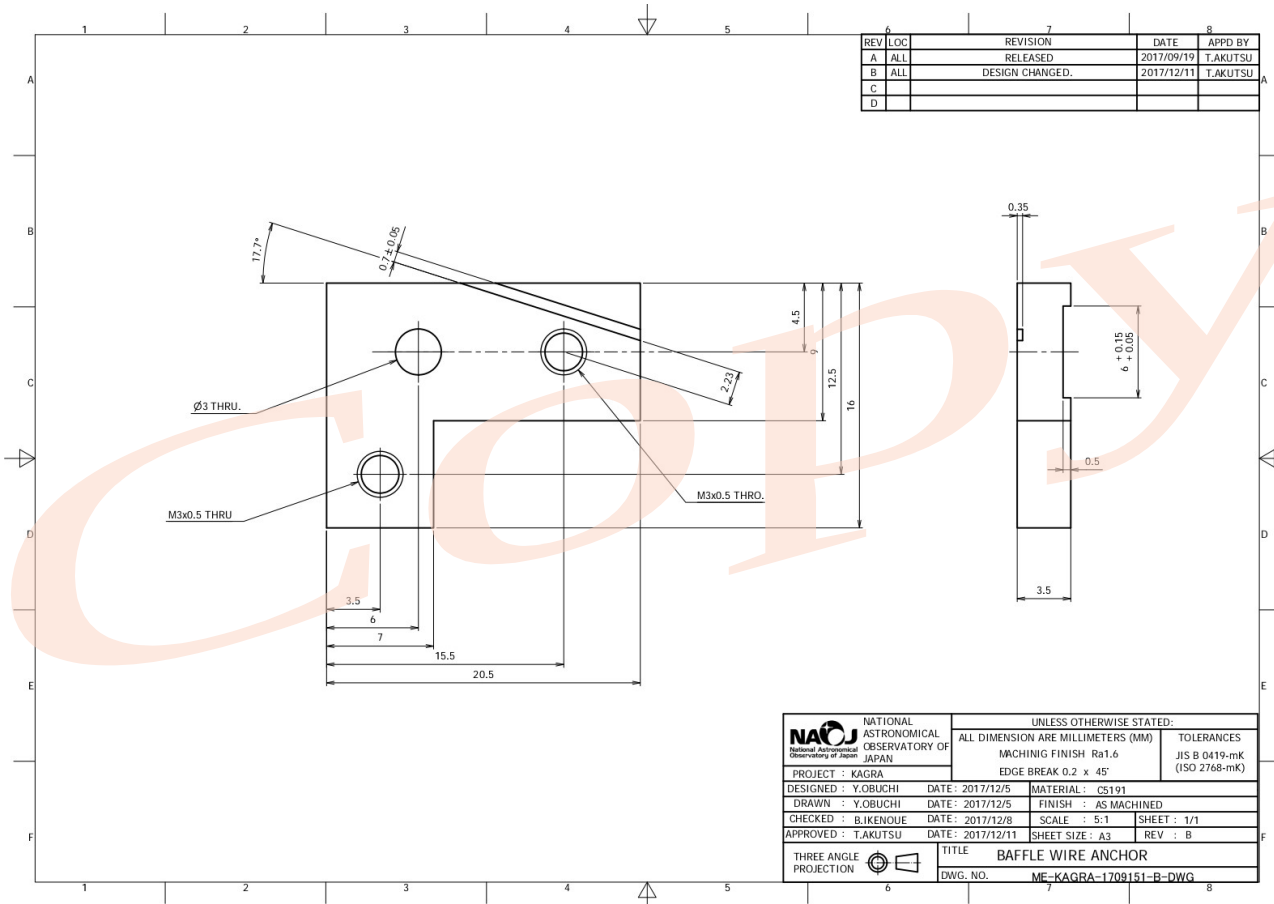

 NATIONAL ASTRONOMICAL OBSERVATORY OF JAPAN <small>National Astronomical Observatory of Japan</small>	UNLESS OTHERWISE STATED:	
	ALL DIMENSION ARE MILLIMETERS (MM)	TOLERANCES
PROJECT : KAGRA	MACHINING FINISH Ra1.6	JIS B 0419-mK (ISO 2768-mK)
DESIGNED : Y.OBUCHI	DATE : 2017/08/07	MATERIAL : C5191
DRAWN : s.saitou	DATE : 2017/08/10	FINISH : AS MACHINED
CHECKED : Y.OBUCHI	DATE : 2017/09/01	SCALE : 5:1 SHEET : 1/1
APPROVED : T.AKUTSU	DATE : 2017/09/19	SHEET SIZE : A3 REV : A
THREE ANGLE PROJECTION 	TITLE Baffle Wire Anchor Washer	
	DWG. NO.	ME-KAGRA-1709150-A-DWG



 NATIONAL ASTRONOMICAL OBSERVATORY OF JAPAN <small>National Astronomical Observatory of Japan</small>	UNLESS OTHERWISE STATED:	
	ALL DIMENSION ARE MILLIMETERS (MM)	TOLERANCES
PROJECT : KAGRA	MACHINING FINISH Ra1.6	JIS B 0419-mK (ISO 2768-mK)
DESIGNED : Y.OBUCHI	DATE : 2017/12/5	MATERIAL : C5191
DRAWN : Y.OBUCHI	DATE : 2017/12/5	FINISH : AS MACHINED
CHECKED : B.IKENOUE	DATE : 2017/12/8	SCALE : 5:1 SHEET : 1/1
APPROVED : T.AKUTSU	DATE : 2017/12/11	SHEET SIZE : A3 REV : B
THREE ANGLE PROJECTION 	TITLE Baffle Wire Anchor	
	DWG. NO.	ME-KAGRA-1709151-R-DWG

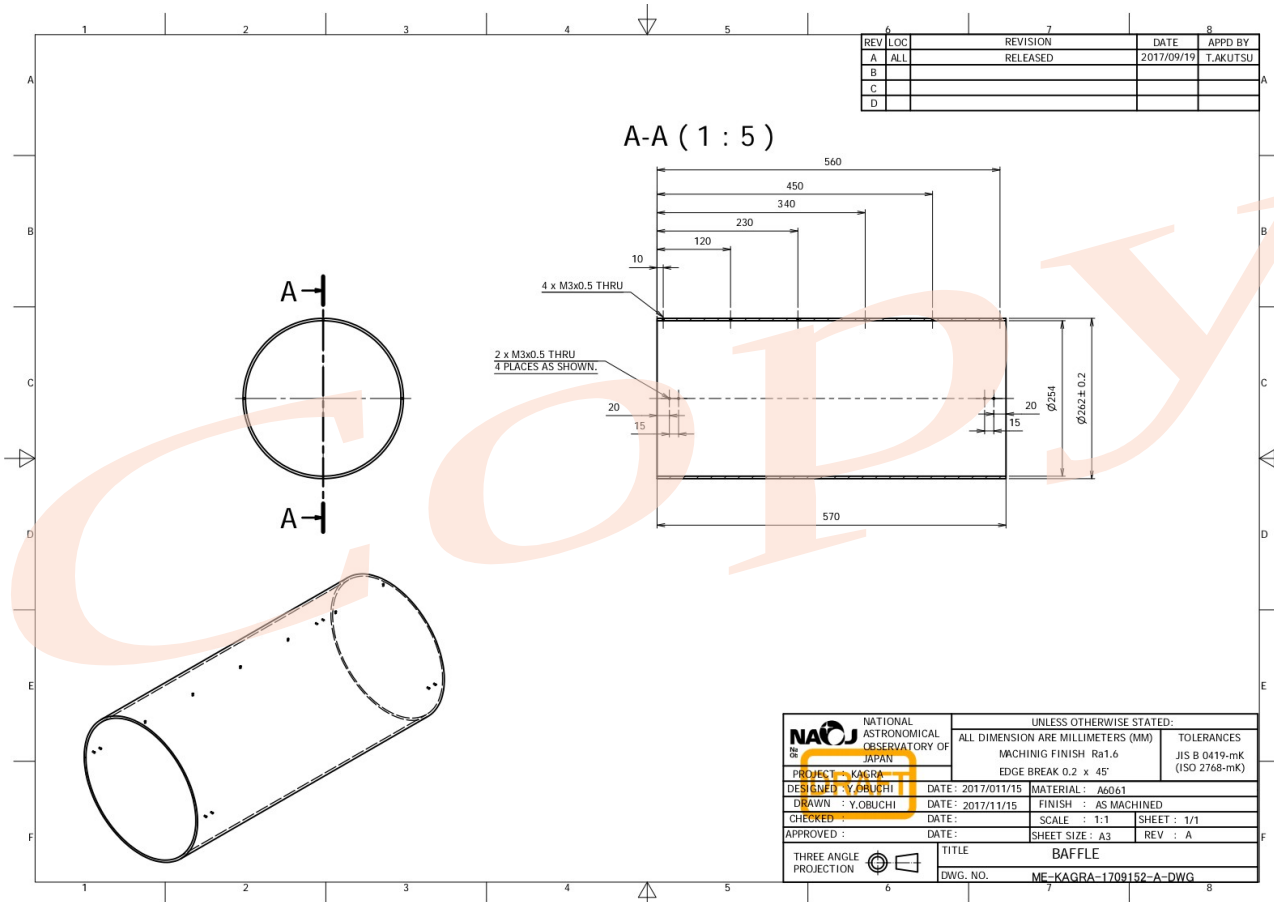
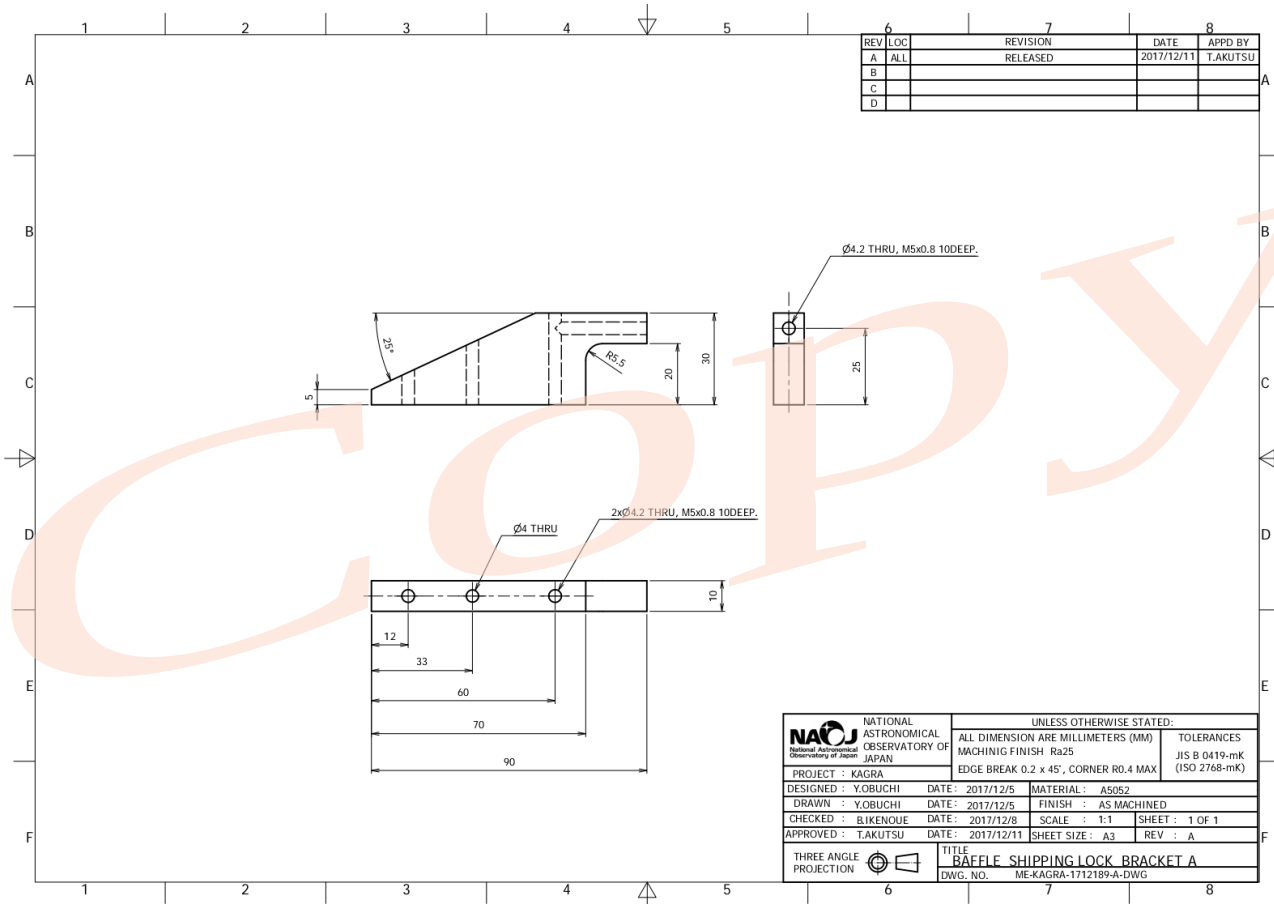

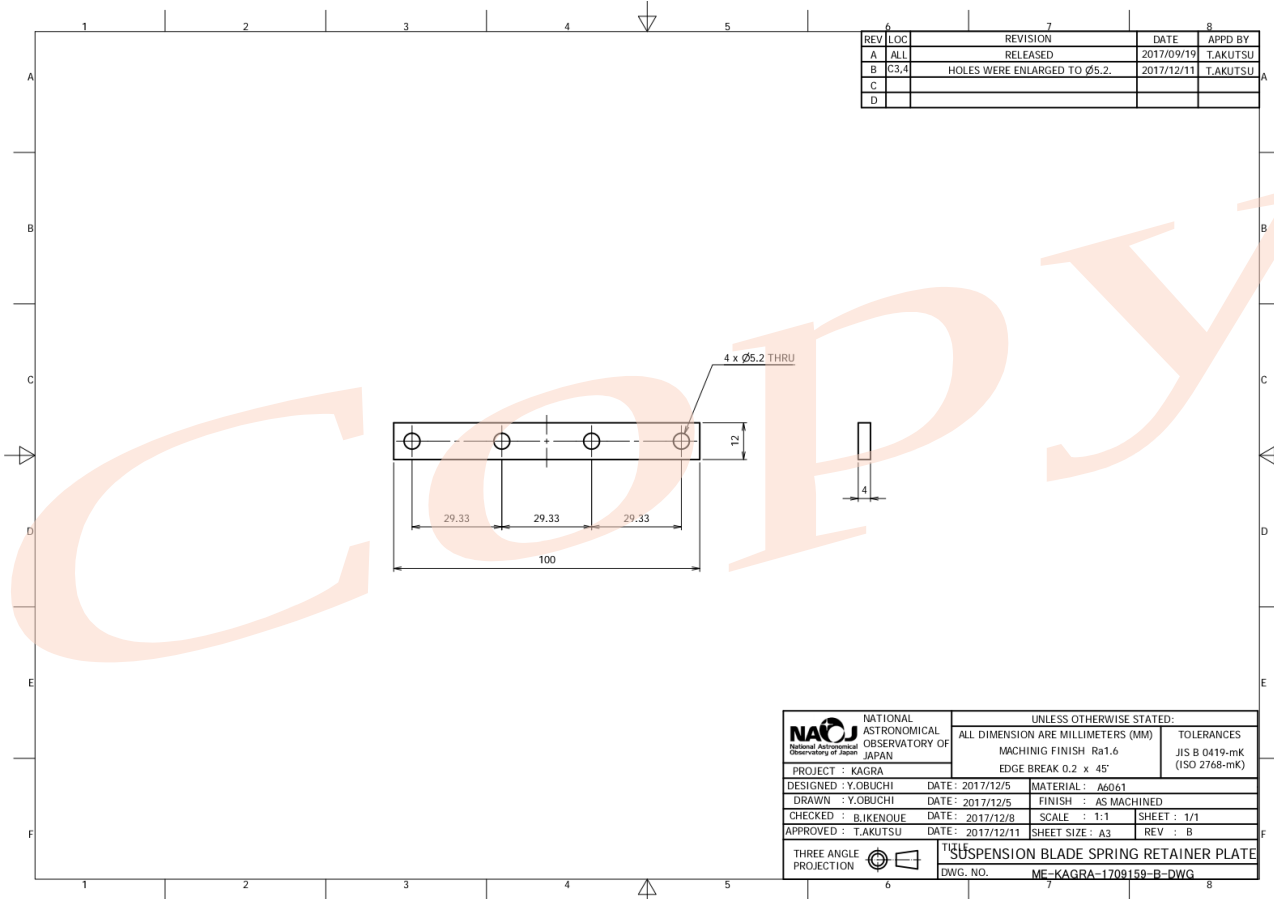
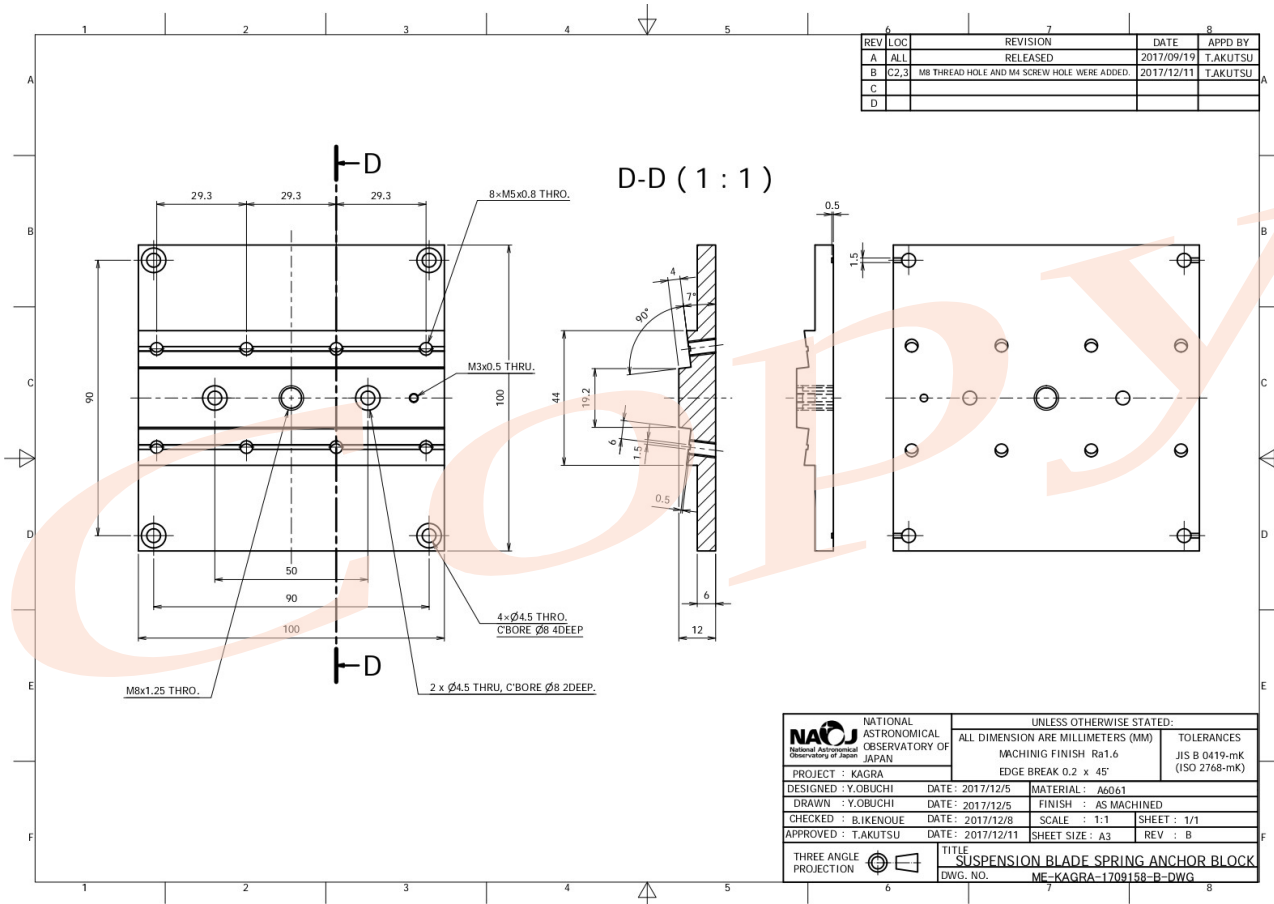

NATIONAL ASTRONOMICAL OBSERVATORY OF JAPAN National Astronomical Observatory of Japan	UNLESS OTHERWISE STATED:	
	ALL DIMENSION ARE MILLIMETERS (MM)	TOLERANCES
PROJECT : KAGRA	MACHINING FINISH Ra1.6	JIS B 0419-mK (ISO 2768-mK)
DESIGNED : Y.OBUCHI	DATE : 2017/12/5	MATERIAL : A6061
DRAWN : Y.OBUCHI	DATE : 2017/12/5	FINISH : AS MACHINED
CHECKED : B.IKENOUE	DATE : 2017/12/8	SCALE : 1:1 SHEET : 1/1
APPROVED : T.AKUTSU	DATE : 2017/12/11	SHEET SIZE : A3 REV : B
THREE ANGLE PROJECTION	TITLE : SUSPENSION BLADE SPRING ANCHOR BLOCK DWG. NO. : ME-KAGRA-1709158-B-DWG	

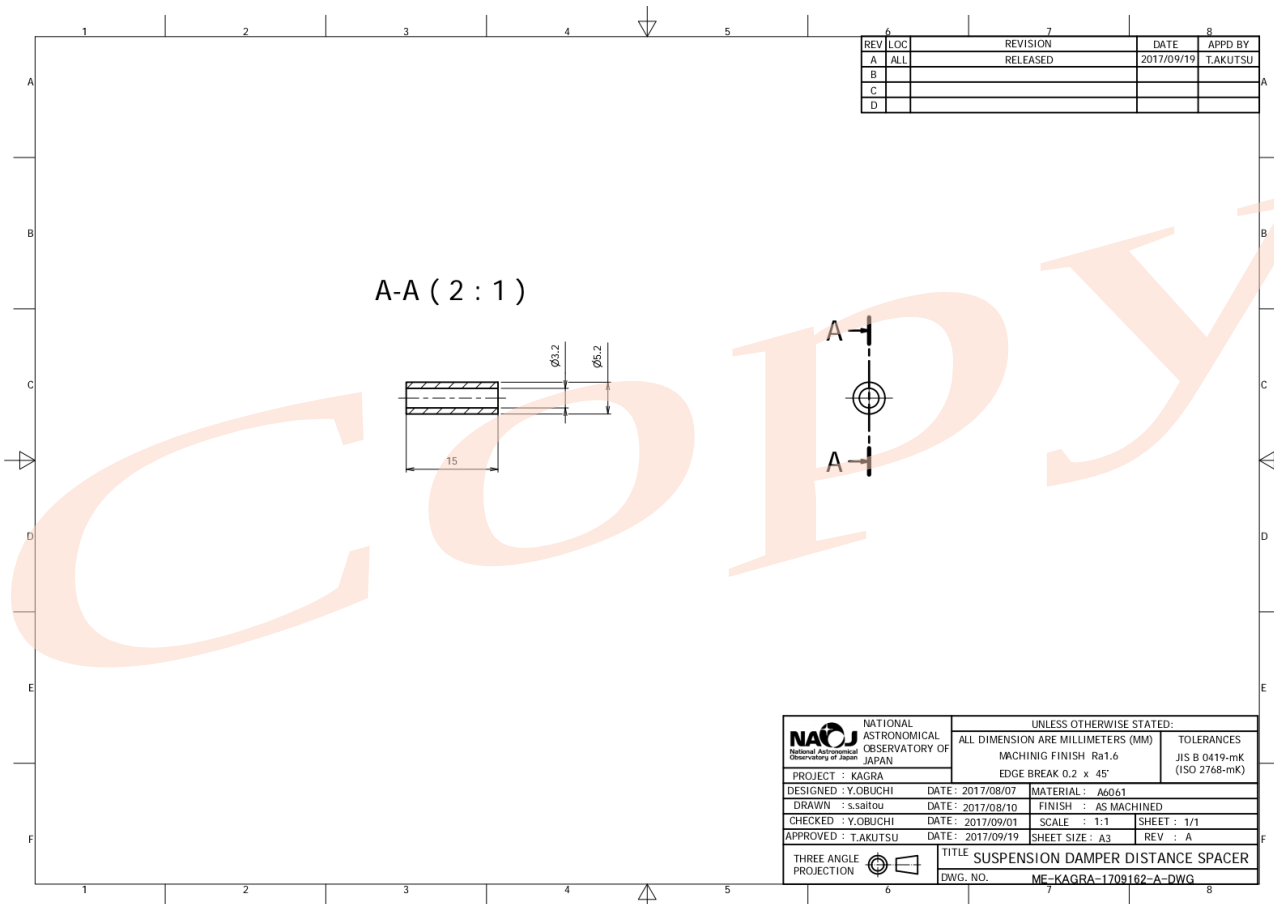
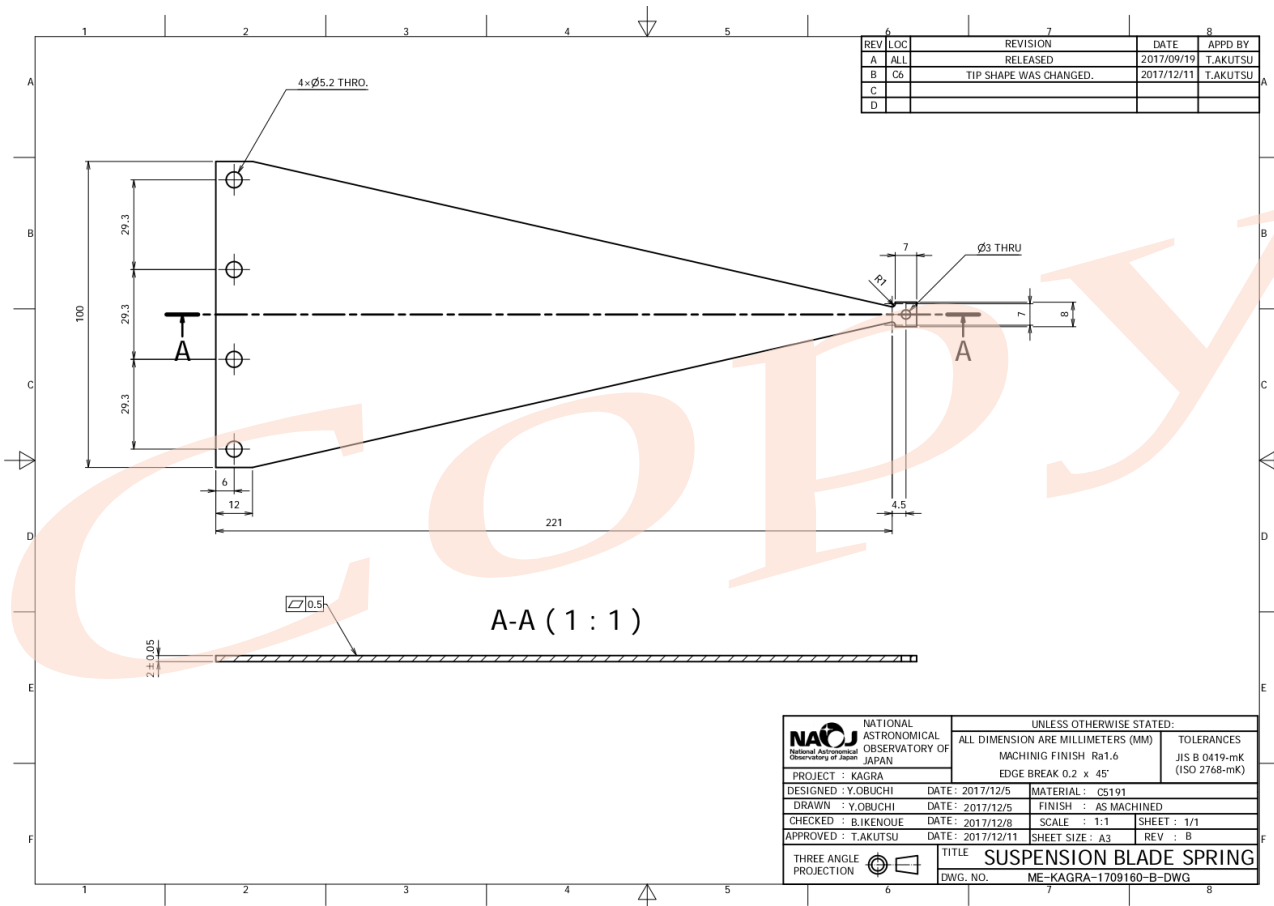

NATIONAL ASTRONOMICAL OBSERVATORY OF JAPAN National Astronomical Observatory of Japan	UNLESS OTHERWISE STATED:	
	ALL DIMENSION ARE MILLIMETERS (MM)	TOLERANCES
PROJECT : KAGRA	MACHINING FINISH Ra1.6	JIS B 0419-mK (ISO 2768-mK)
DESIGNED : Y.OBUCHI	DATE : 2017/12/5	MATERIAL : A6061
DRAWN : Y.OBUCHI	DATE : 2017/12/5	FINISH : AS MACHINED
CHECKED : B.IKENOUE	DATE : 2017/12/8	SCALE : 1:1 SHEET : 1/1
APPROVED : T.AKUTSU	DATE : 2017/12/11	SHEET SIZE : A3 REV : B
THREE ANGLE PROJECTION	TITLE : SUSPENSION BLADE SPRING RETAINER PLATE DWG. NO. : ME-KAGRA-1709159-R-DWG	

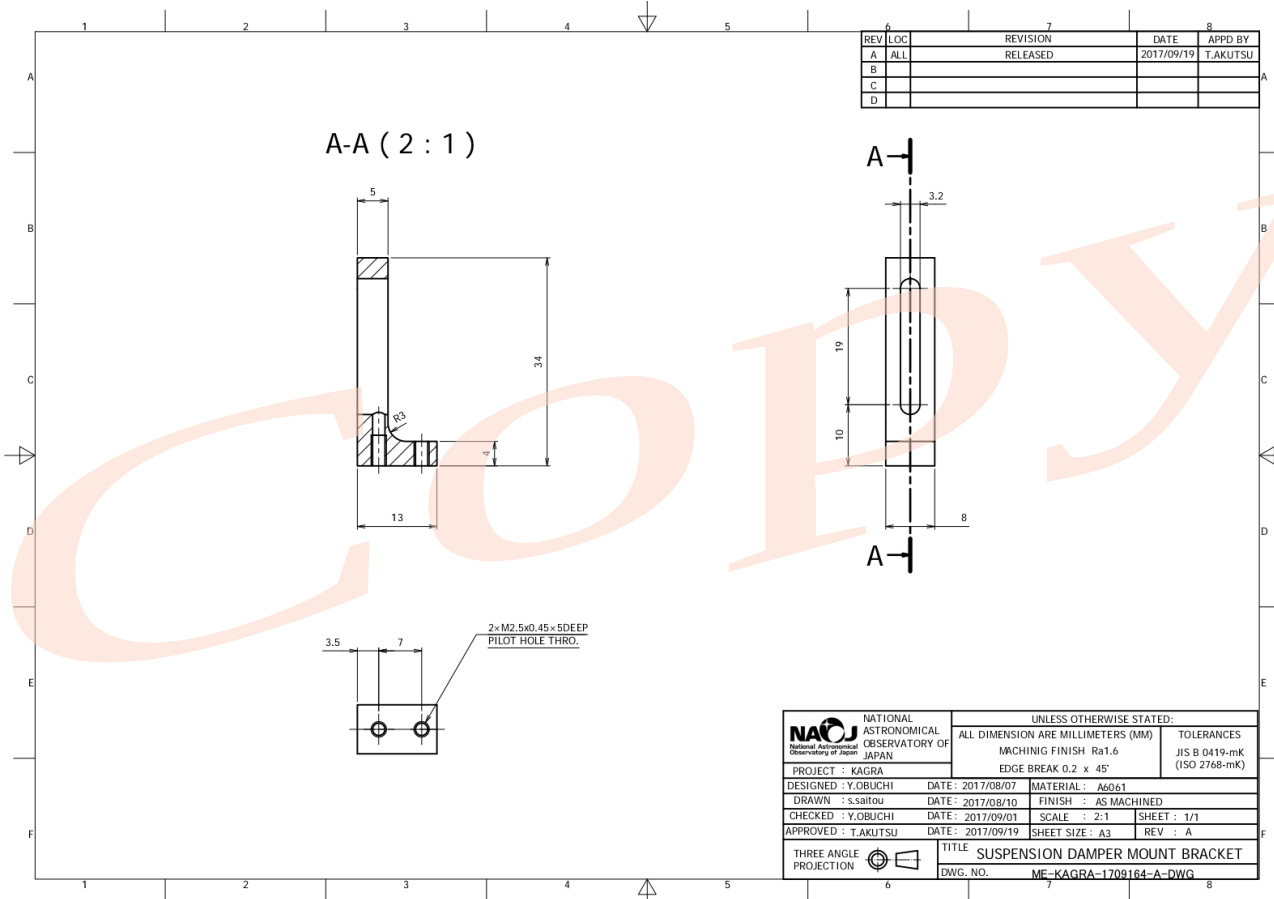
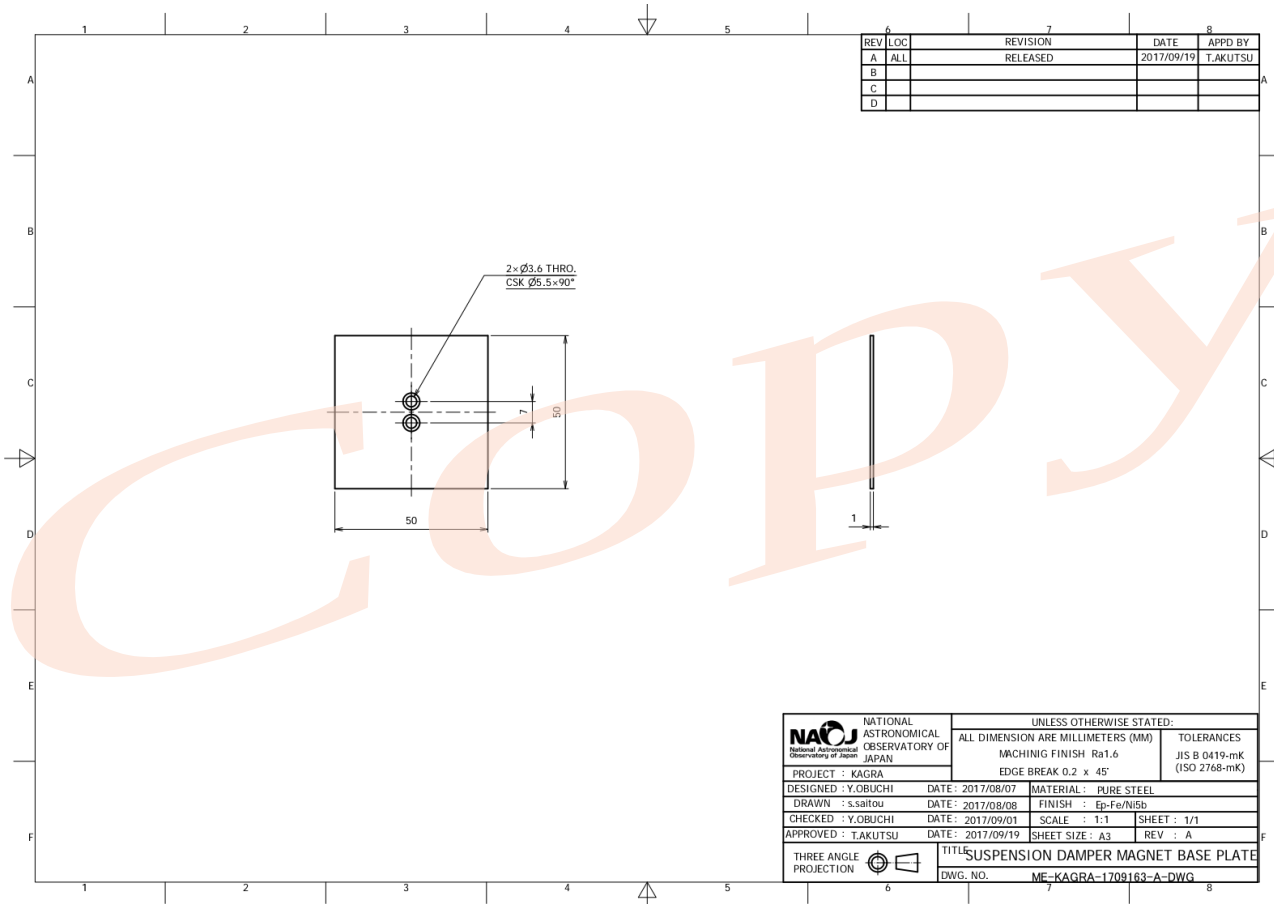

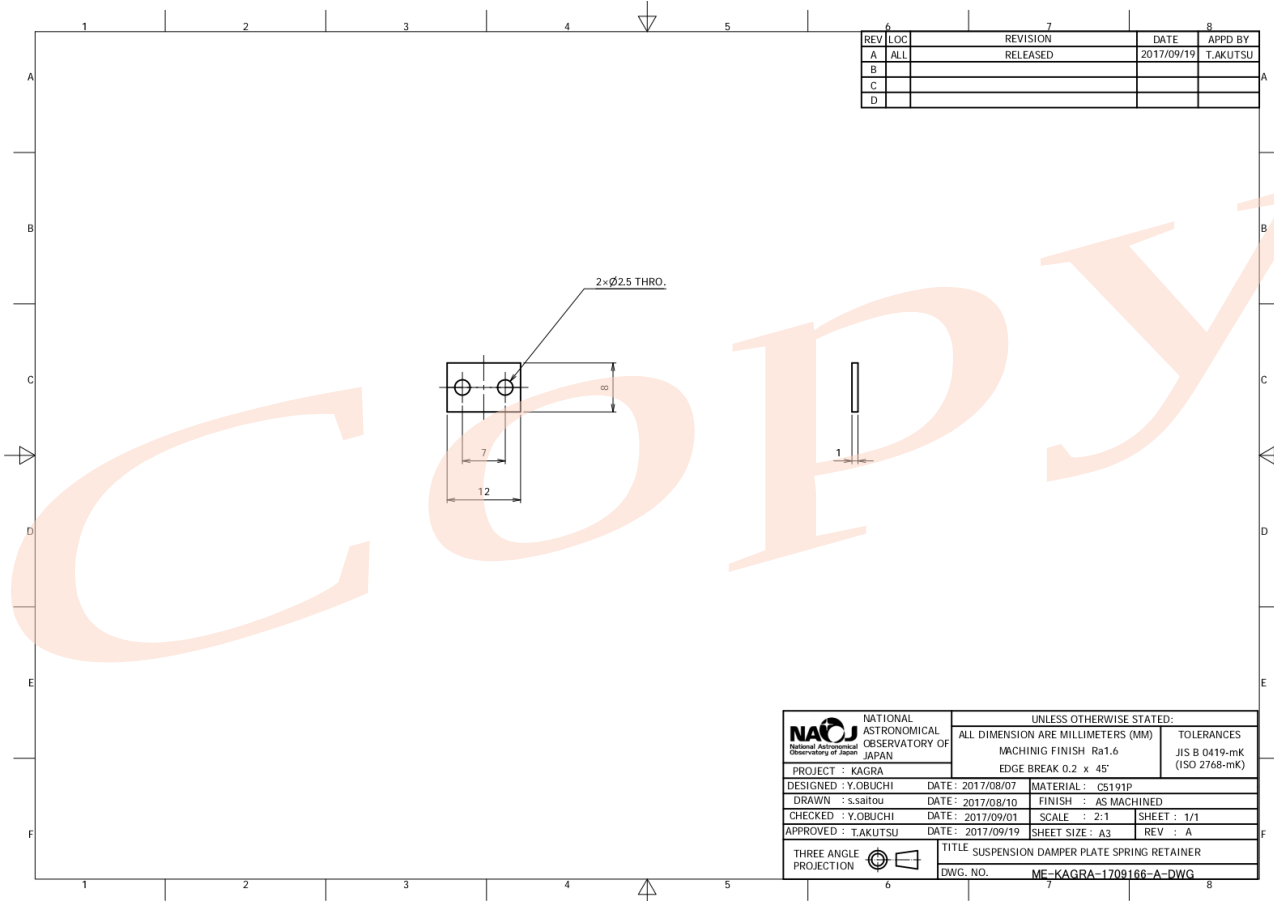
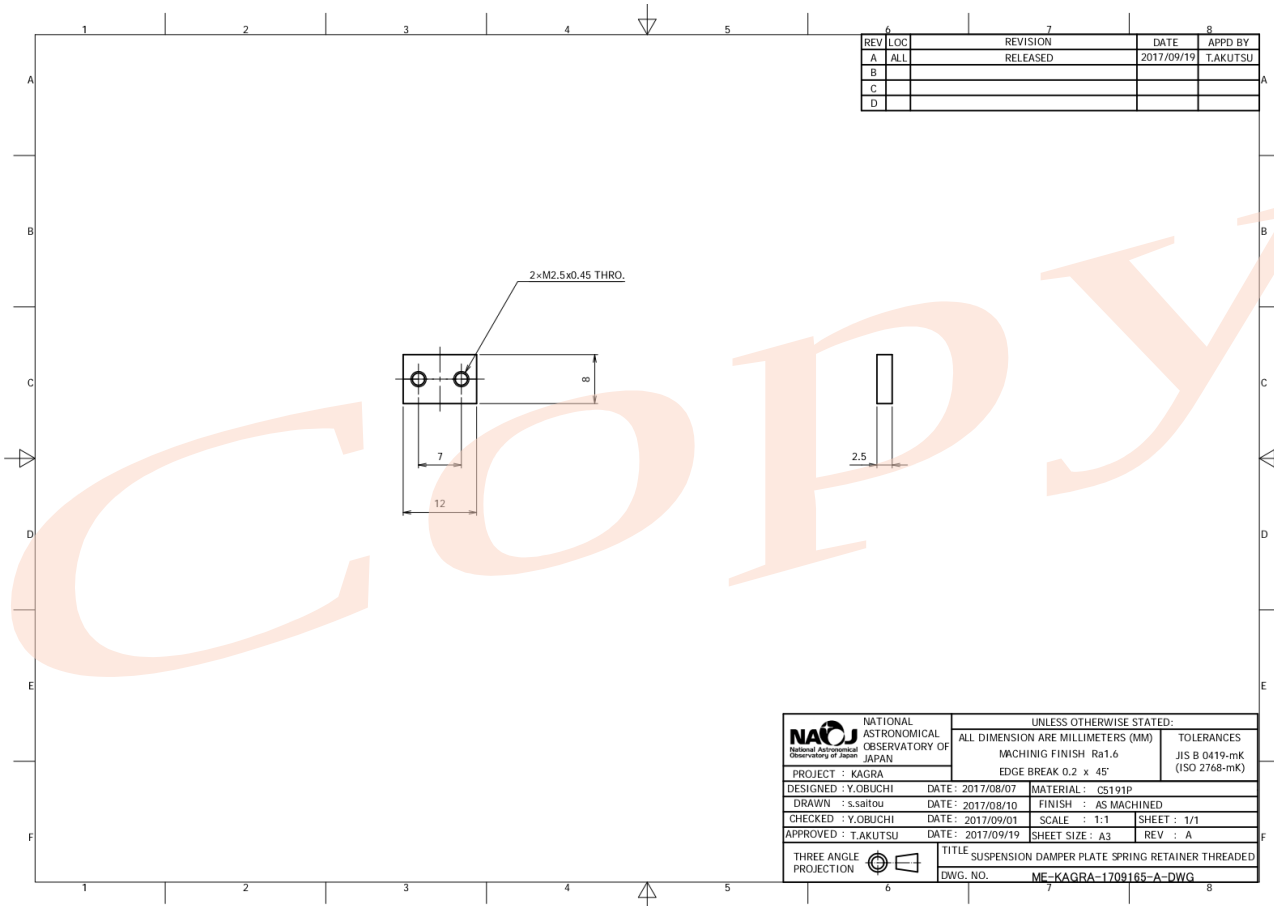

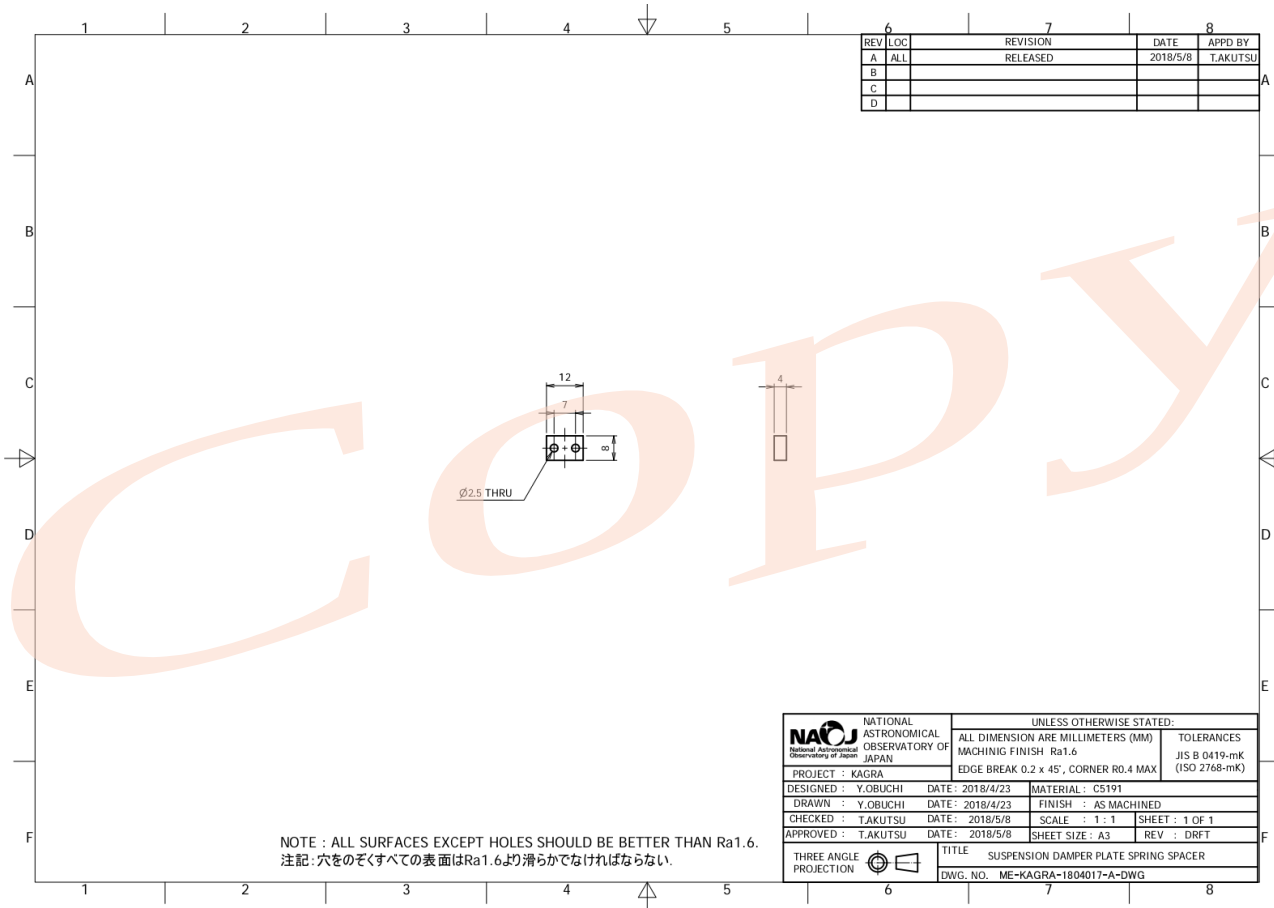



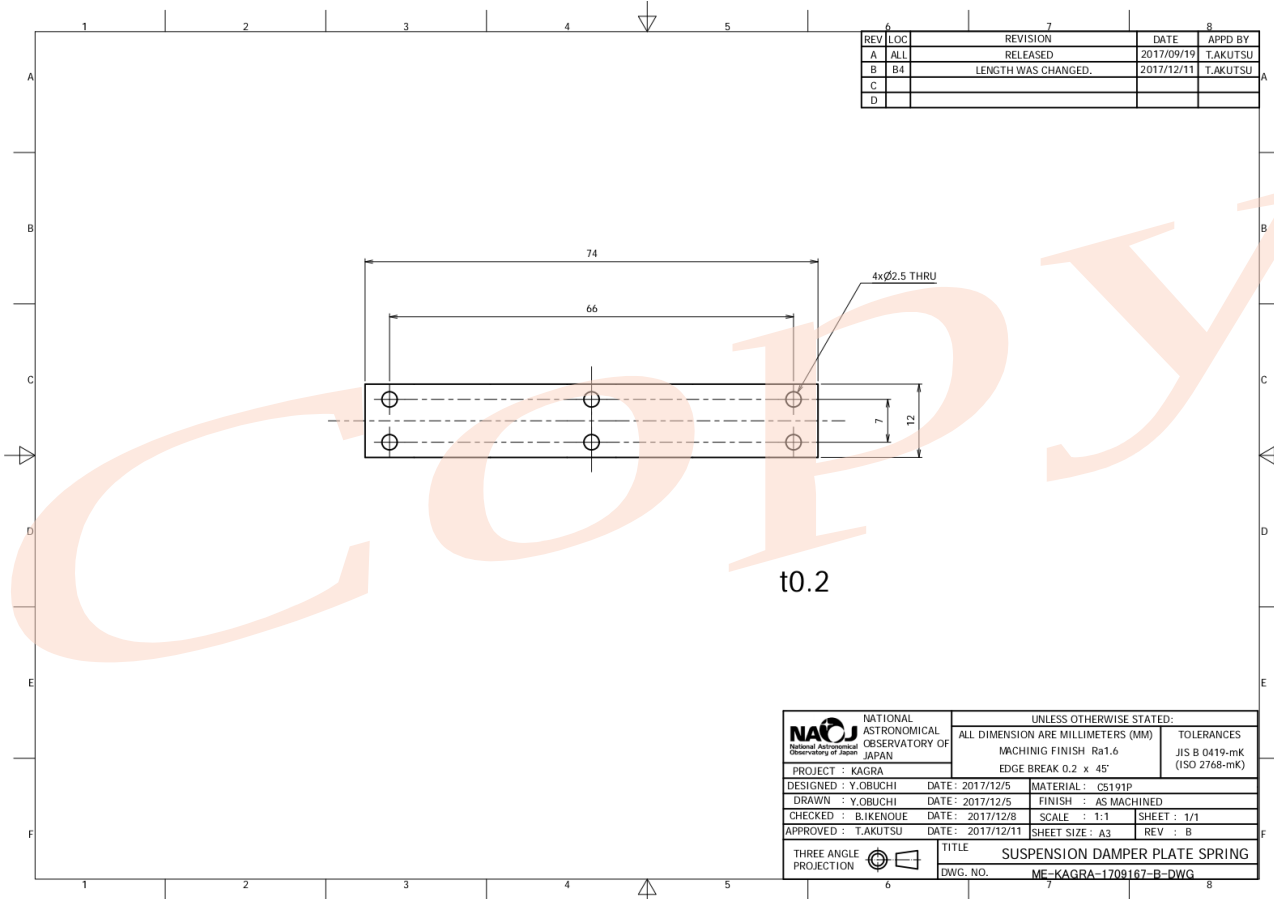

 NATIONAL ASTRONOMICAL OBSERVATORY OF JAPAN <small>National Astronomical Observatory of Japan</small>	UNLESS OTHERWISE STATED:	
	ALL DIMENSION ARE MILLIMETERS (MM)	TOLERANCES
PROJECT : KAGRA	EDGE BREAK 0.2 x 45°, CORNER R0.4 MAX	JIS B 0419-mK (ISO 2768-mK)
DESIGNED : Y.OBUCHI	DATE : 2018/4/23	MATERIAL : C5191
DRAWN : Y.OBUCHI	DATE : 2018/4/23	FINISH : AS MACHINED
CHECKED : TAKUTSU	DATE : 2018/5/8	SCALE : 1 : 1 SHEET : 1 OF 1
APPROVED : TAKUTSU	DATE : 2018/5/8	SHEET SIZE : A3 REV : DRFT
THREE ANGLE PROJECTION 	TITLE SUSPENSION DAMPER PLATE SPRING SPACER	
	DWG. NO. ME-KAGRA-1804017-A-DWG	



 NATIONAL ASTRONOMICAL OBSERVATORY OF JAPAN <small>National Astronomical Observatory of Japan</small>	UNLESS OTHERWISE STATED:	
	ALL DIMENSION ARE MILLIMETERS (MM)	TOLERANCES
PROJECT : KAGRA	EDGE BREAK 0.2 x 45°	JIS B 0419-mK (ISO 2768-mK)
DESIGNED : Y.OBUCHI	DATE : 2017/12/5	MATERIAL : C5191P
DRAWN : Y.OBUCHI	DATE : 2017/12/5	FINISH : AS MACHINED
CHECKED : B.IKENOUE	DATE : 2017/12/8	SCALE : 1:1 SHEET : 1/1
APPROVED : T.AKUTSU	DATE : 2017/12/11	SHEET SIZE : A3 REV : B
THREE ANGLE PROJECTION 	TITLE SUSPENSION DAMPER PLATE SPRING	
	DWG. NO. ME-KAGRA-1709167-R-DWG	

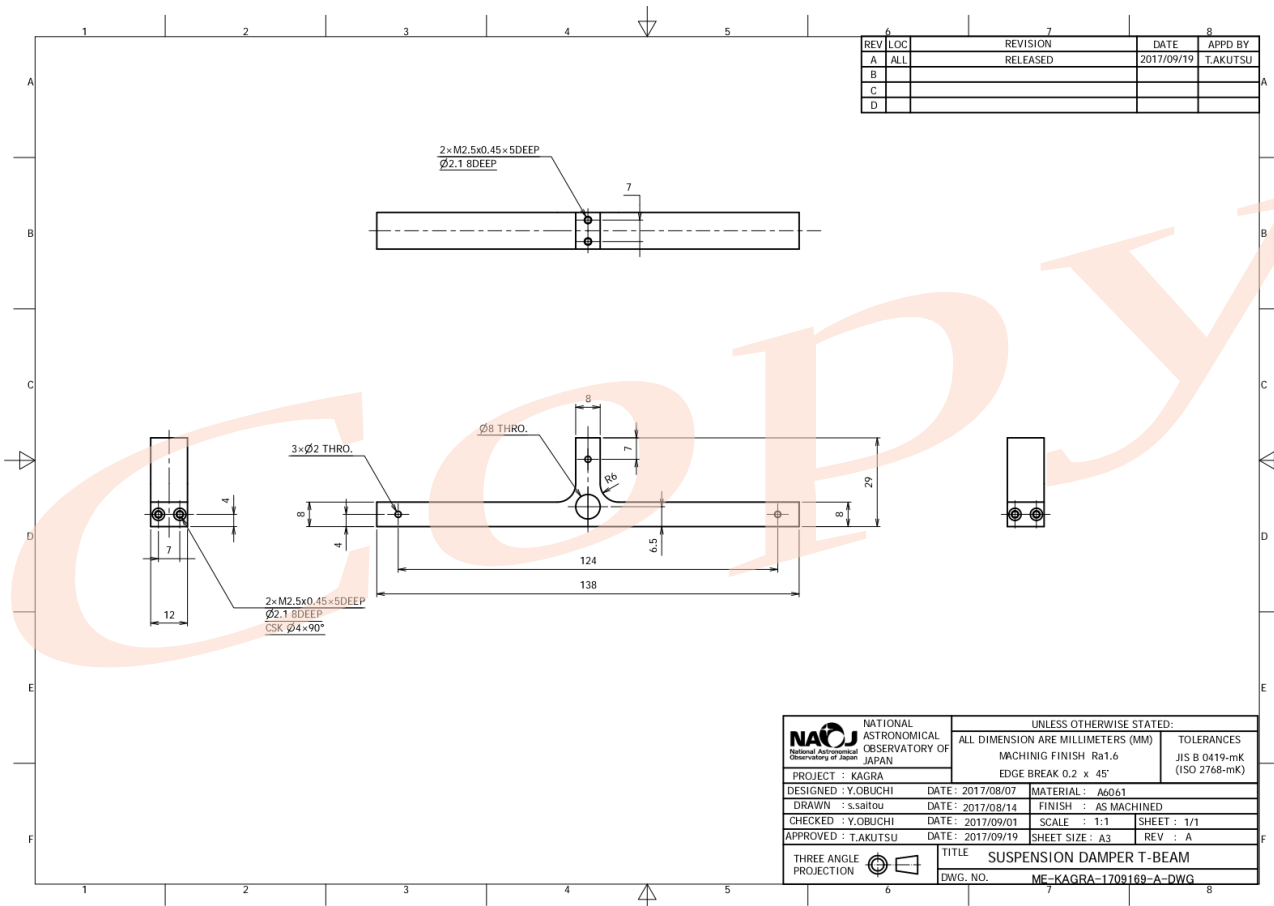
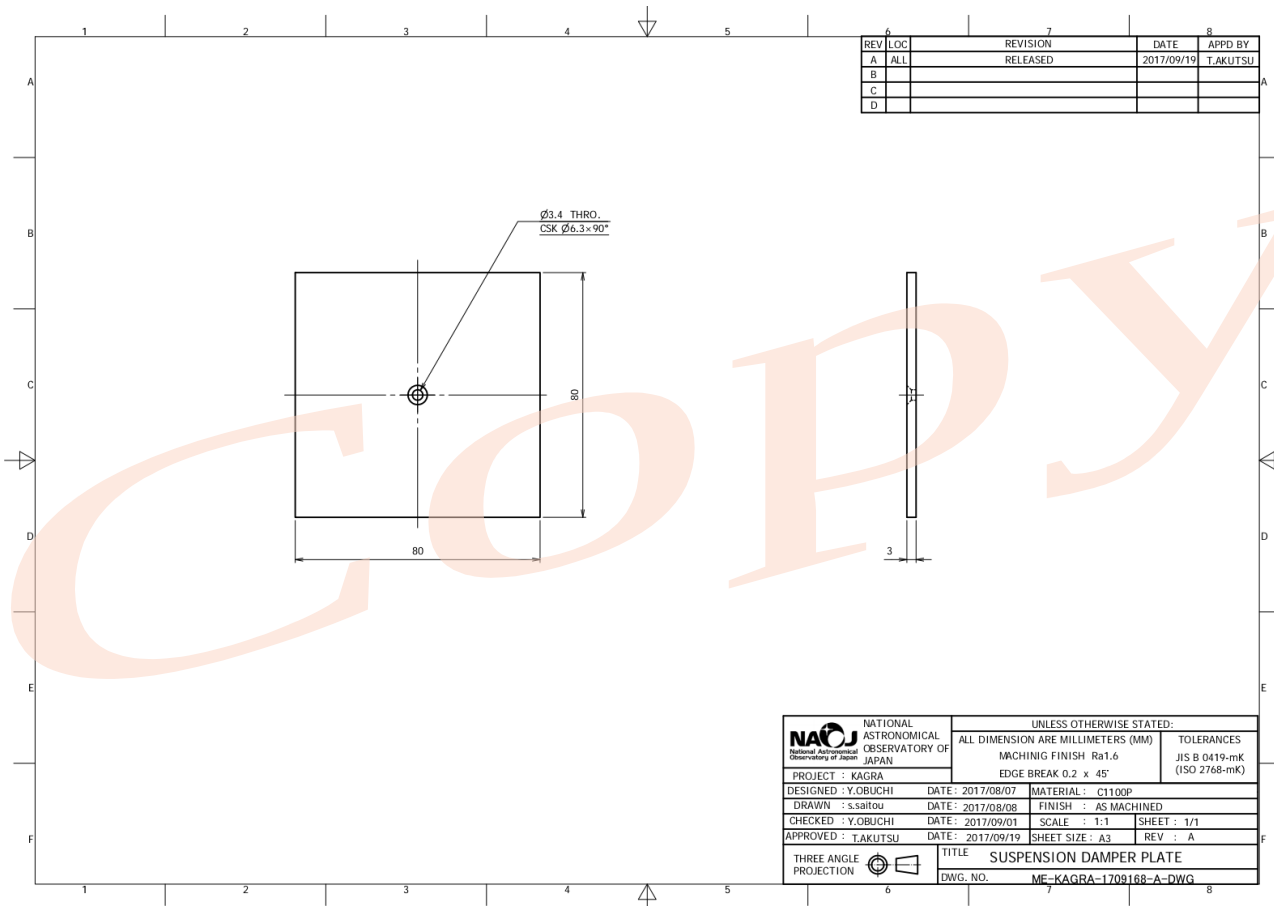

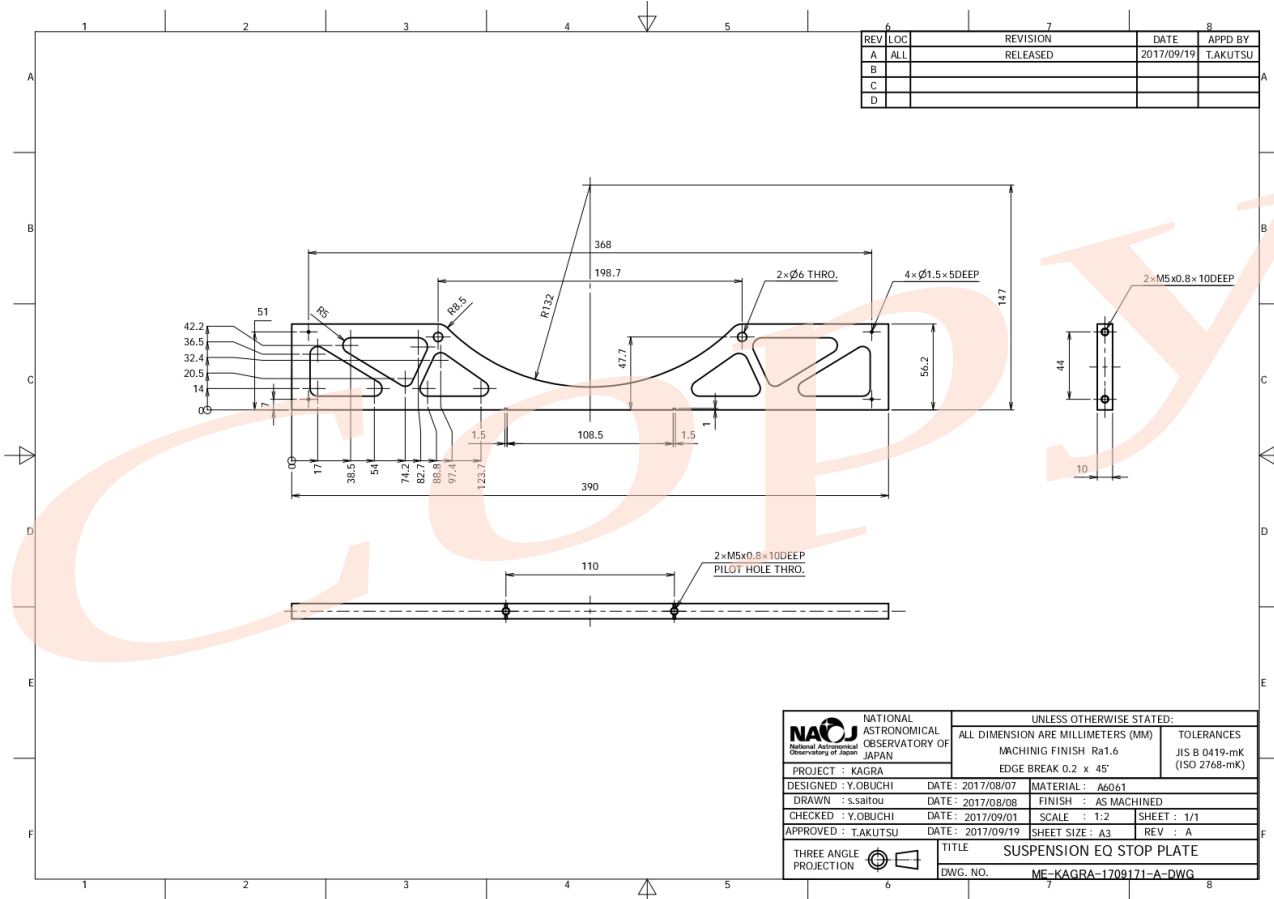
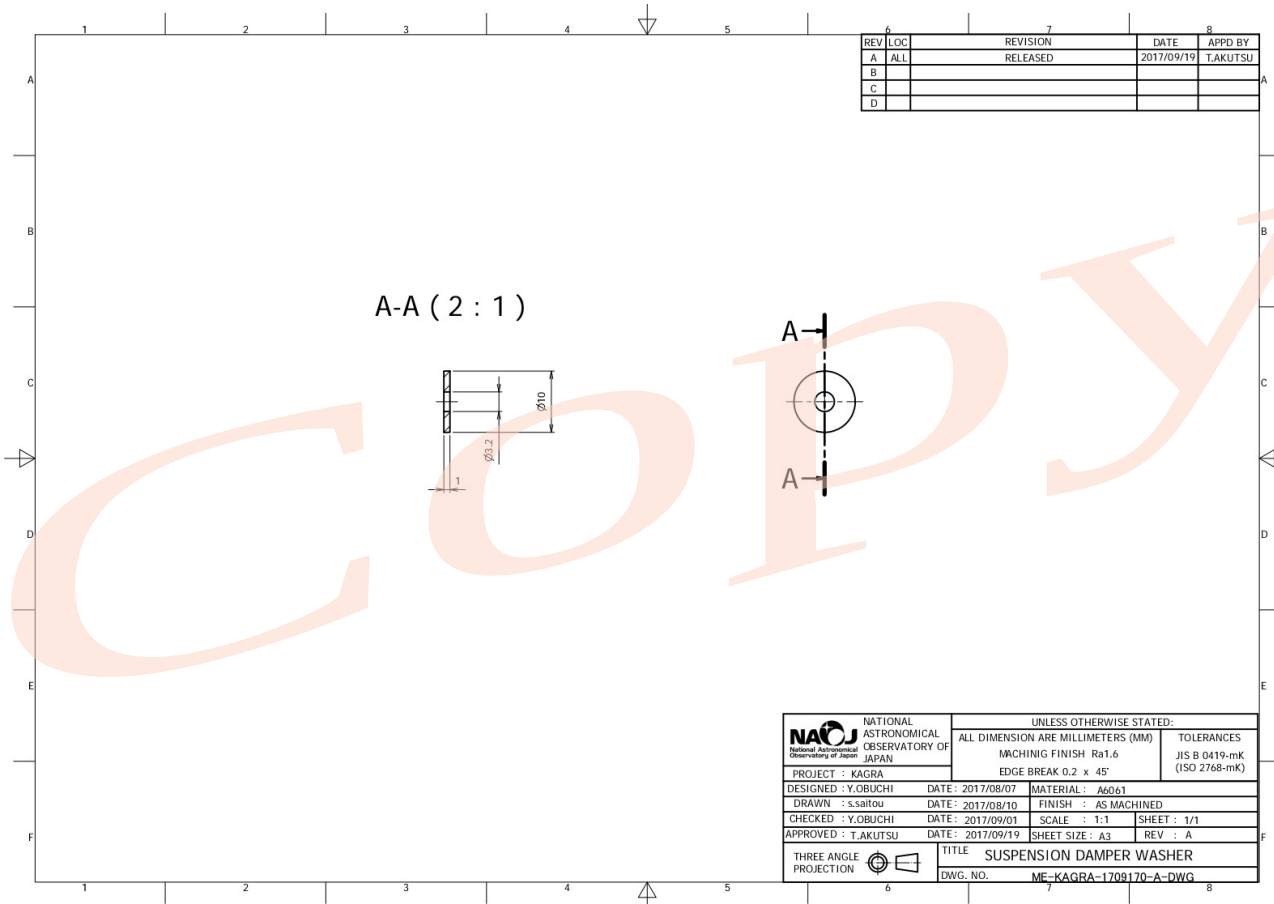

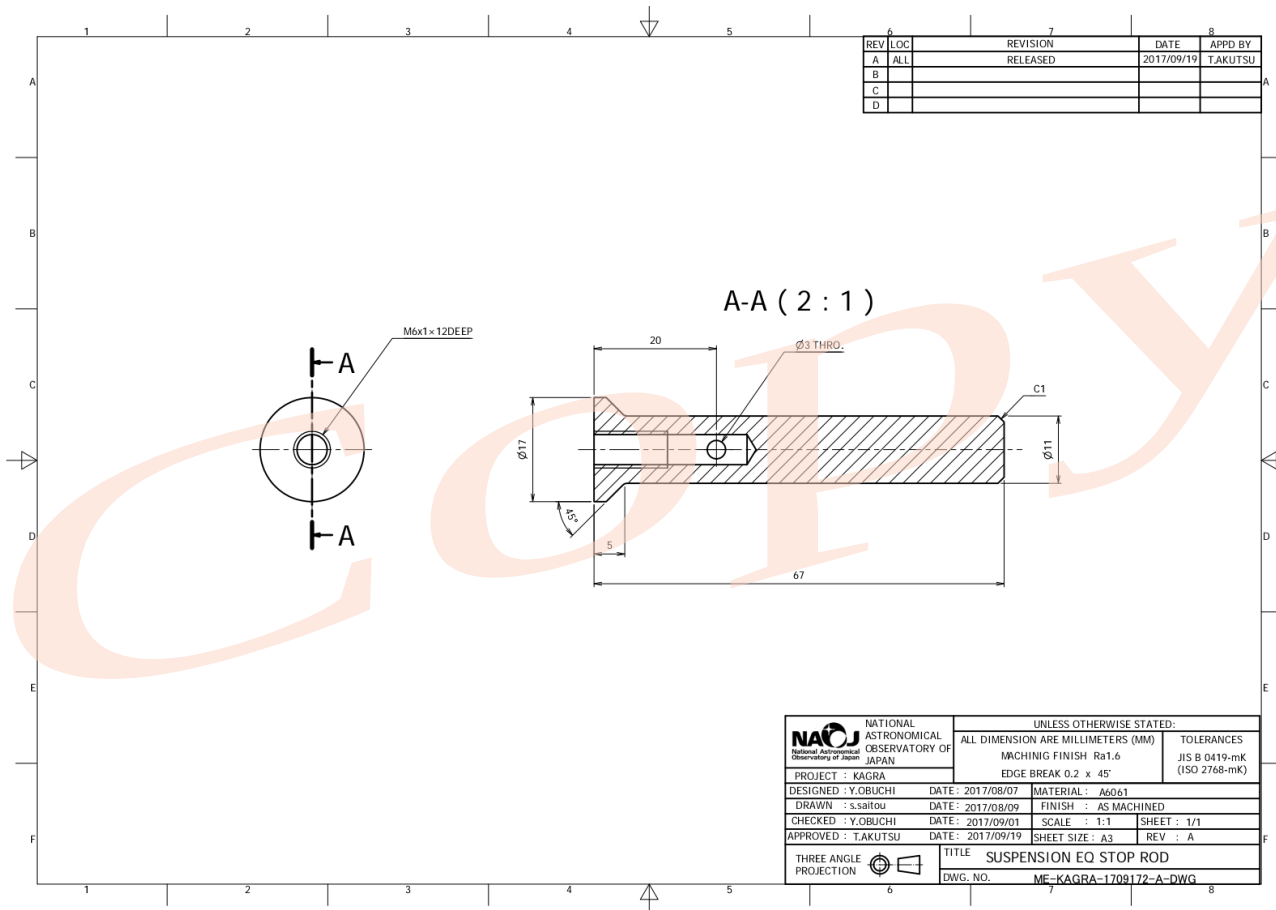

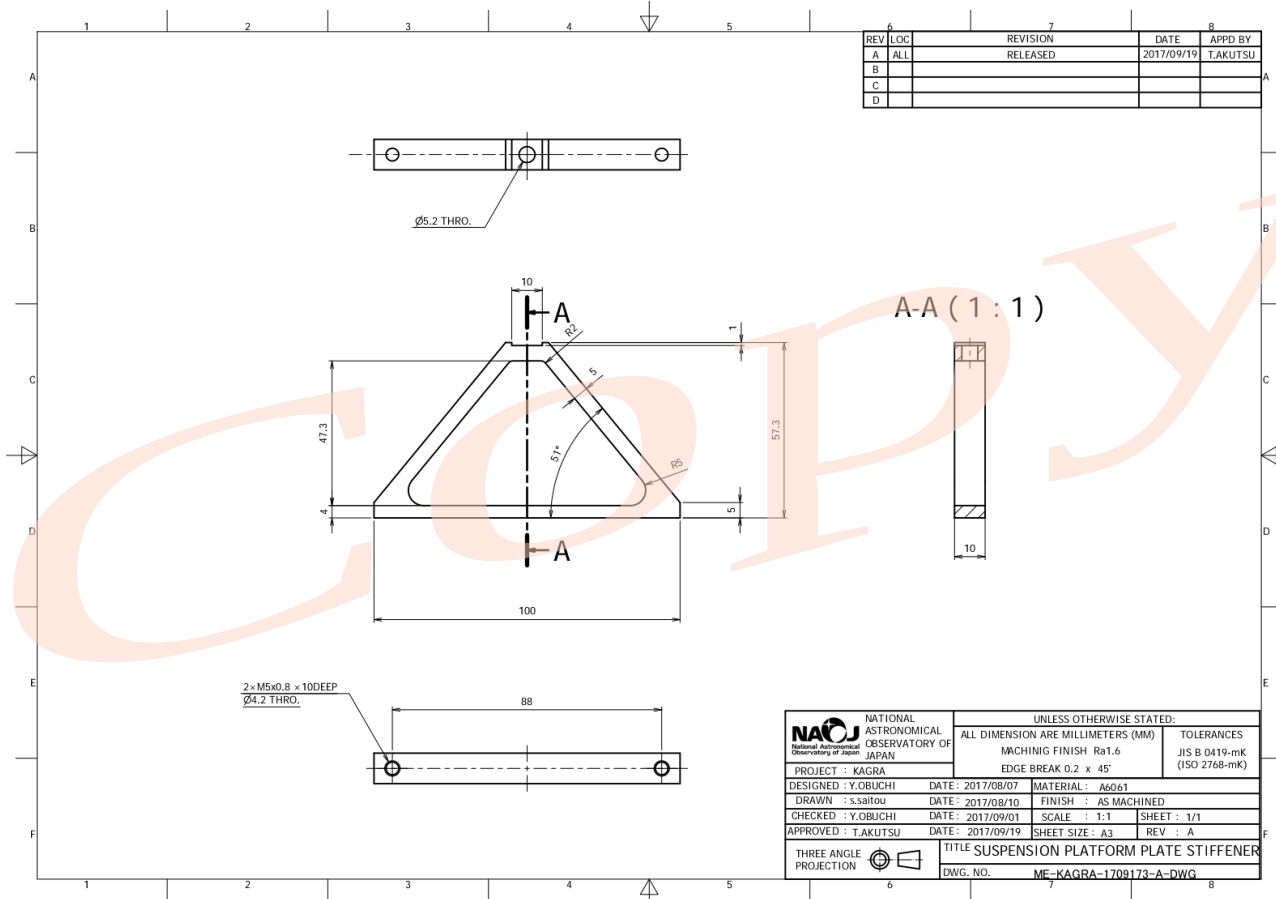

 NATIONAL ASTRONOMICAL OBSERVATORY OF JAPAN <small>National Astronomical Observatory of Japan</small>	UNLESS OTHERWISE STATED:		
	ALL DIMENSION ARE MILLIMETERS (MM)	TOLERANCES	
PROJECT : KAGRA	MACHINING FINISH Ra1.6	JIS B 0419-mK (ISO 2768-mK)	
DESIGNED : Y.OBUCHI	DATE : 2017/08/07	MATERIAL : A6061	
DRAWN : s.saitou	DATE : 2017/08/09	FINISH : AS MACHINED	
CHECKED : Y.OBUCHI	DATE : 2017/09/01	SCALE : 1:1	SHEET : 1/1
APPROVED : TAKUTSU	DATE : 2017/09/19	SHEET SIZE : A3	REV : A
THREE ANGLE PROJECTION	TITLE SUSPENSION EQ STOP ROD		
	DWG. NO.	ME-KAGRA-1709172-A-DWG	



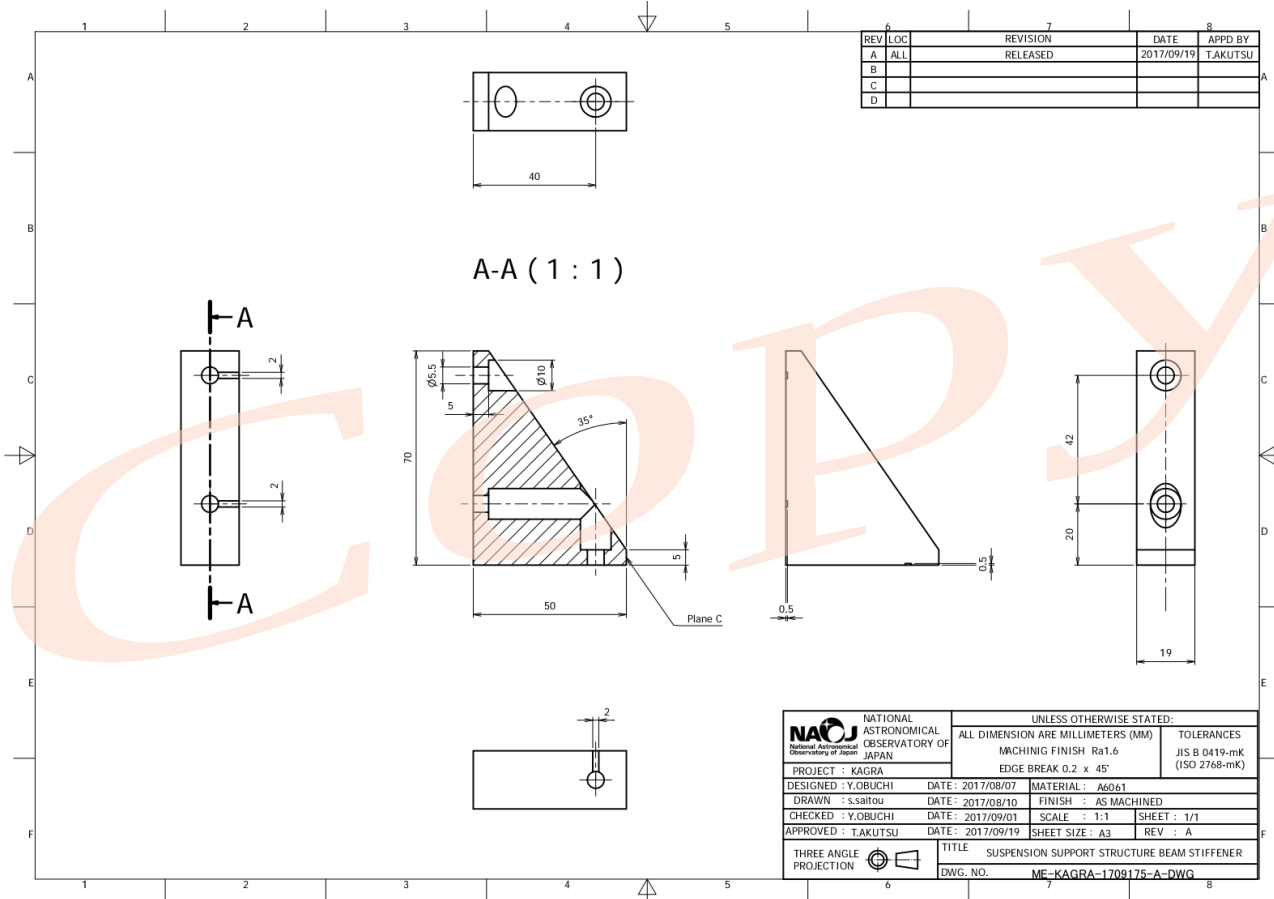
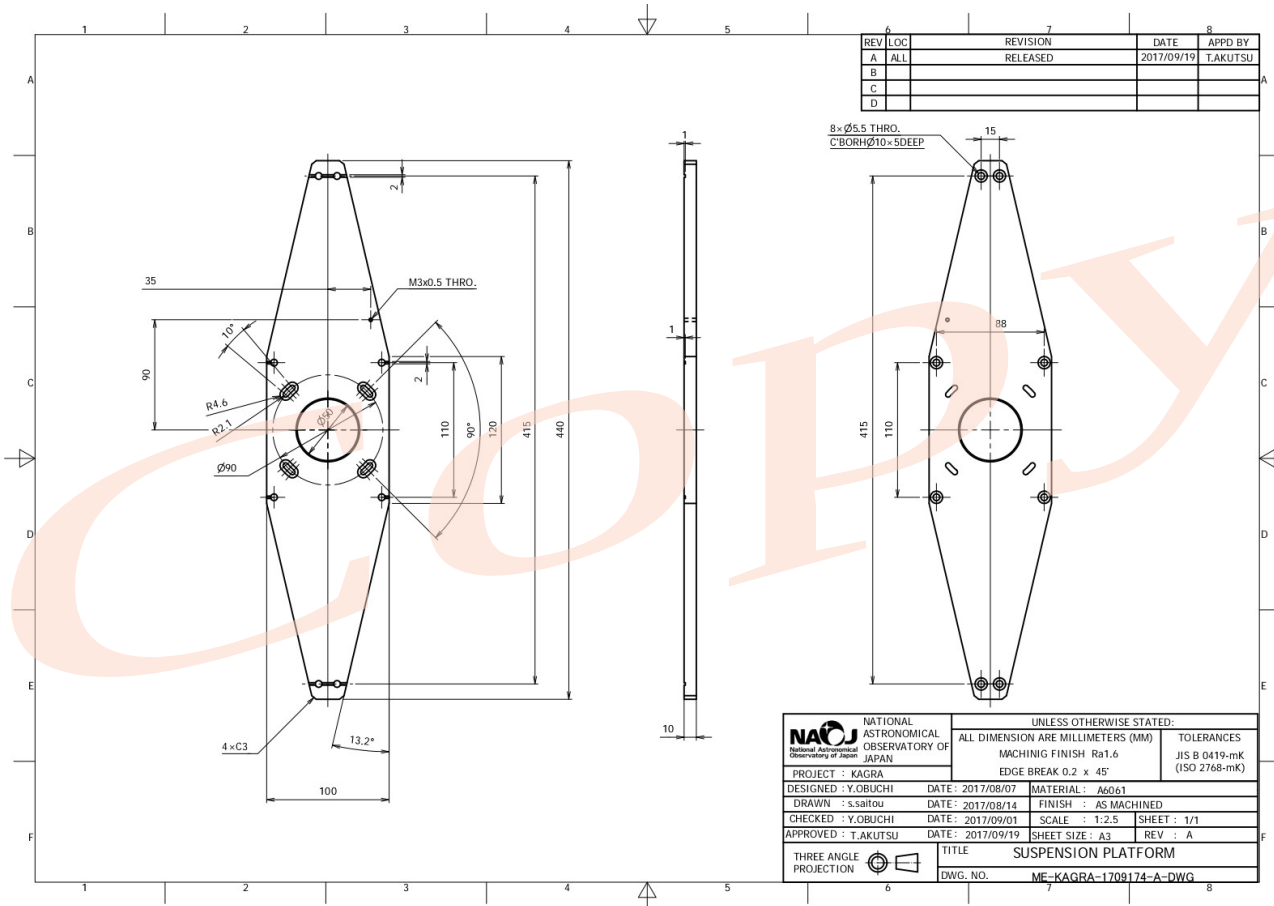

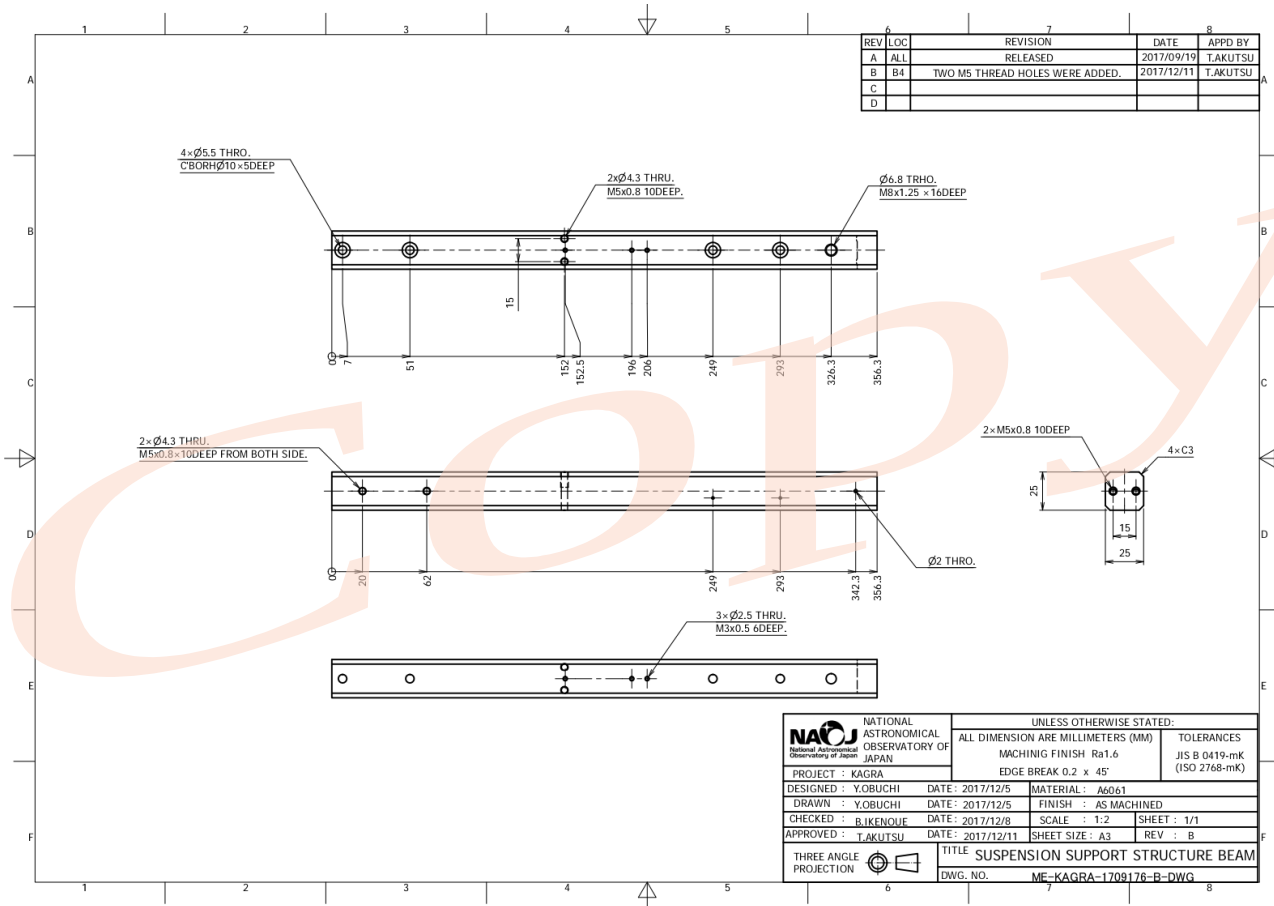
 NATIONAL ASTRONOMICAL OBSERVATORY OF JAPAN <small>National Astronomical Observatory of Japan</small>	UNLESS OTHERWISE STATED:		
	ALL DIMENSION ARE MILLIMETERS (MM)	TOLERANCES	
PROJECT : KAGRA	MACHINING FINISH Ra1.6	JIS B 0419-mK (ISO 2768-mK)	
DESIGNED : Y.OBUCHI	DATE : 2017/08/07	MATERIAL : A6061	
DRAWN : s.saitou	DATE : 2017/08/10	FINISH : AS MACHINED	
CHECKED : Y.OBUCHI	DATE : 2017/09/01	SCALE : 1:1	SHEET : 1/1
APPROVED : T.AKUTSU	DATE : 2017/09/19	SHEET SIZE : A3	REV : A
THREE ANGLE PROJECTION	TITLE SUSPENSION PLATFORM PLATE STIFFENER		
	DWG. NO.	ME-KAGRA-1709173-A-DWG	



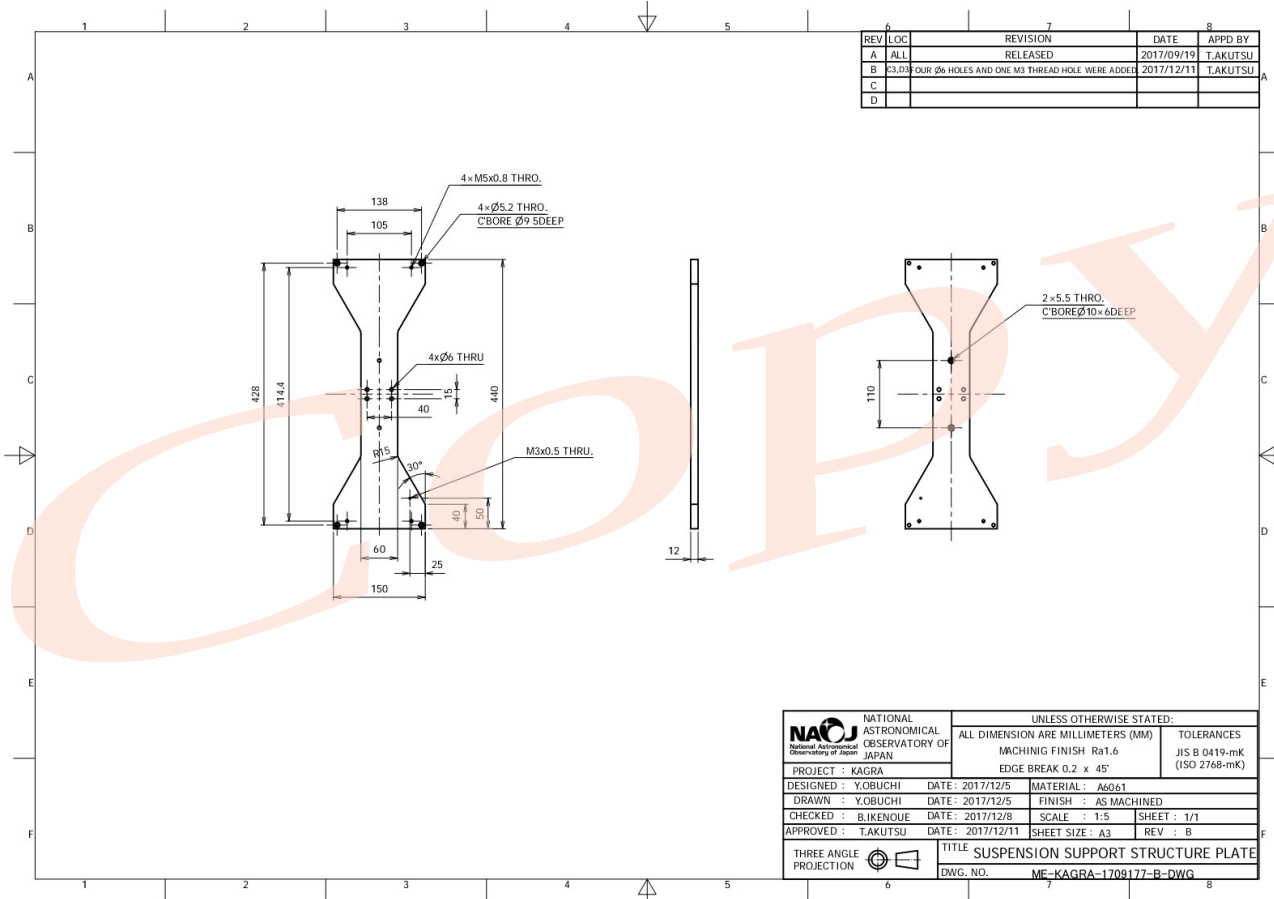

 NATIONAL ASTRONOMICAL OBSERVATORY OF JAPAN <small>National Astronomical Observatory of Japan</small>	UNLESS OTHERWISE STATED:	
	ALL DIMENSION ARE MILLIMETERS (MM)	TOLERANCES JIS B 0419-mK (ISO 2768-mK)
PROJECT : KAGRA	DATE : 2017/12/5	MATERIAL : A6061
DESIGNED : Y.OBUCHI	DATE : 2017/12/5	FINISH : AS MACHINED
CHECKED : B.IKENOUE	DATE : 2017/12/8	SCALE : 1:2 SHEET : 1/1
APPROVED : T.AKUTSU	DATE : 2017/12/11	SHEET SIZE : A3 REV : B
THREE ANGLE PROJECTION	TITLE SUSPENSION SUPPORT STRUCTURE BEAM	
	DWG. NO. MF-KAGRA-1709176-B-DWG	



 NATIONAL ASTRONOMICAL OBSERVATORY OF JAPAN <small>National Astronomical Observatory of Japan</small>	UNLESS OTHERWISE STATED:	
	ALL DIMENSION ARE MILLIMETERS (MM)	TOLERANCES JIS B 0419-mK (ISO 2768-mK)
PROJECT : KAGRA	DATE : 2017/12/5	MATERIAL : A6061
DESIGNED : Y.OBUCHI	DATE : 2017/12/5	FINISH : AS MACHINED
CHECKED : B.IKENOUE	DATE : 2017/12/8	SCALE : 1:5 SHEET : 1/1
APPROVED : T.AKUTSU	DATE : 2017/12/11	SHEET SIZE : A3 REV : B
THREE ANGLE PROJECTION	TITLE SUSPENSION SUPPORT STRUCTURE PLATE	
	DWG. NO. MF-KAGRA-1709177-R-DWG	

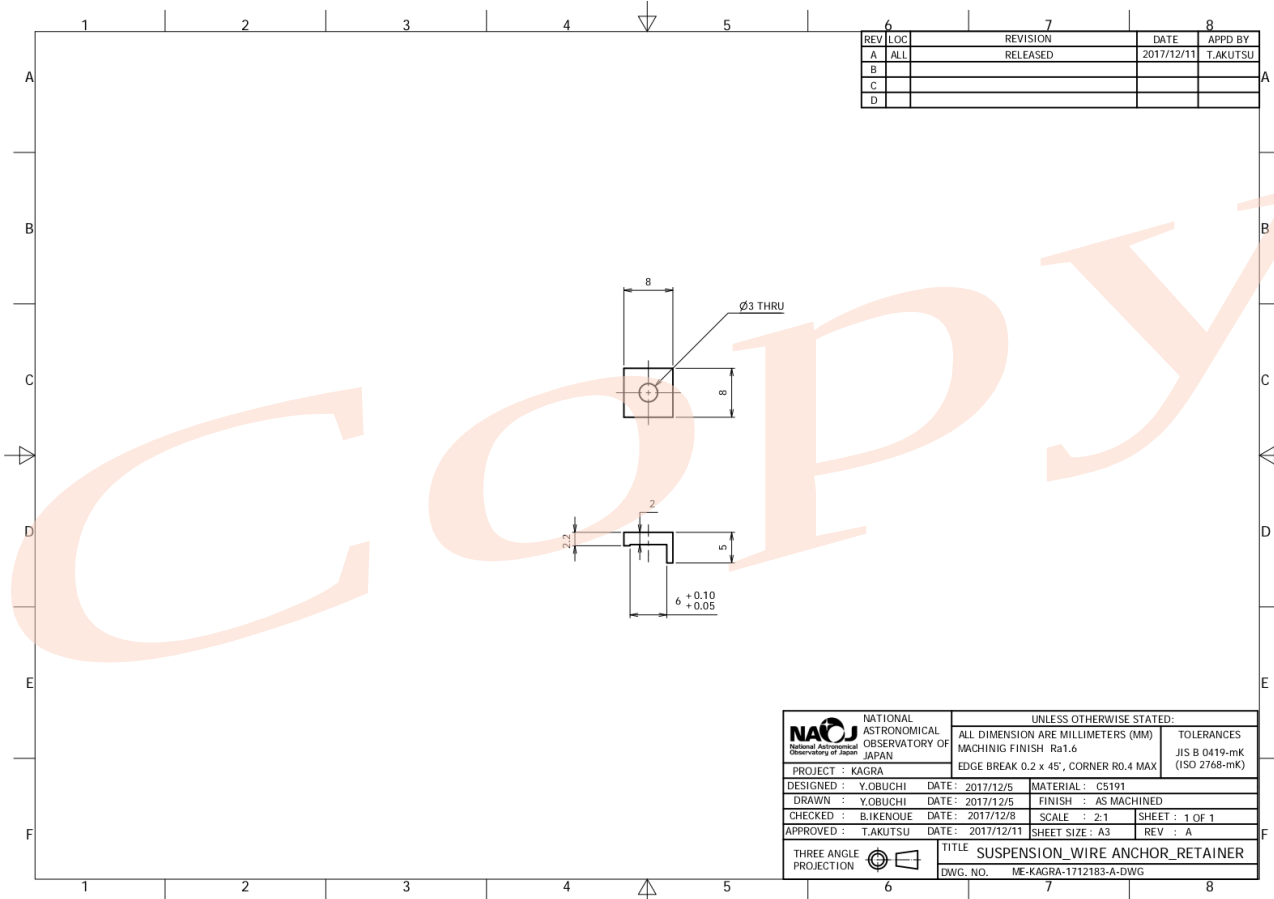
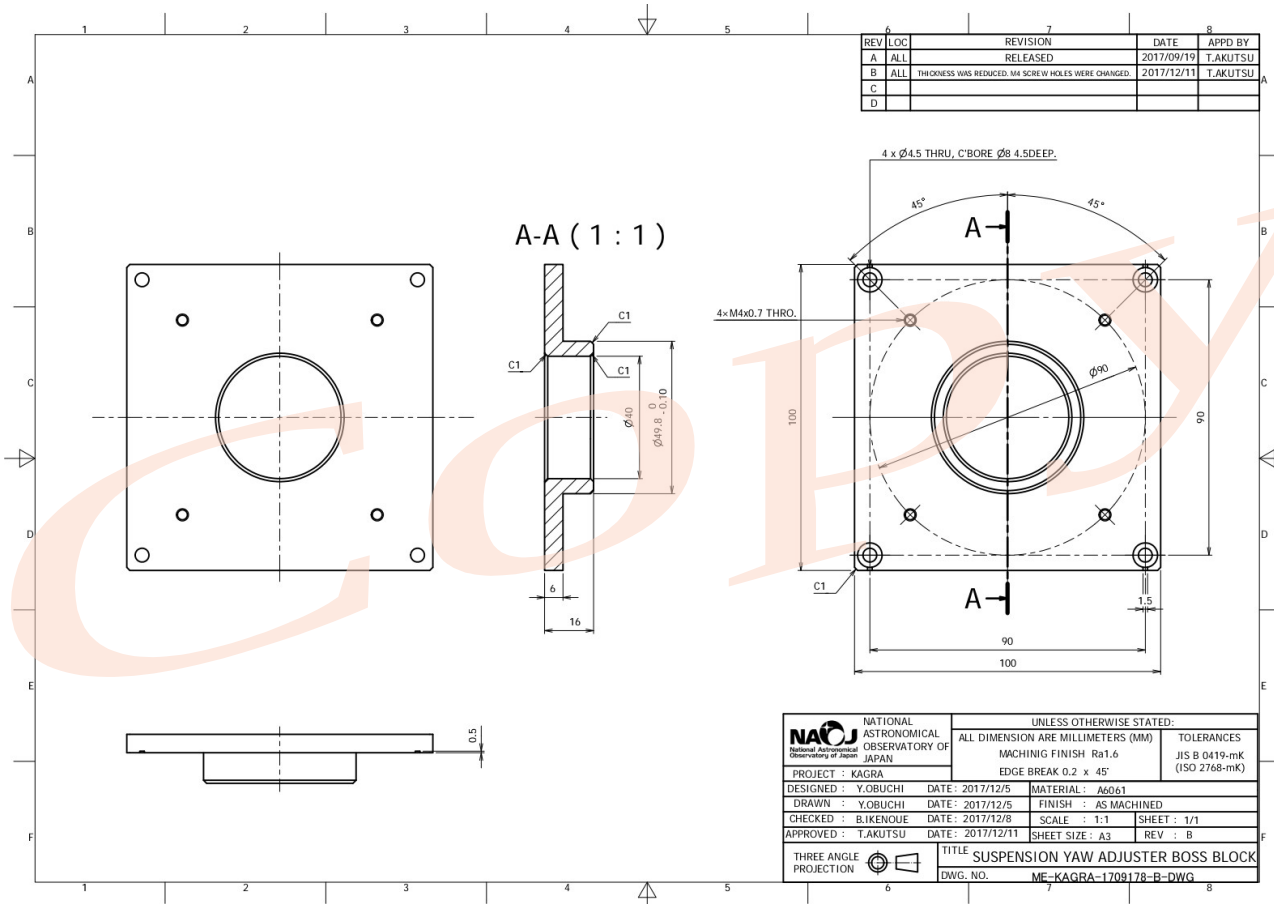

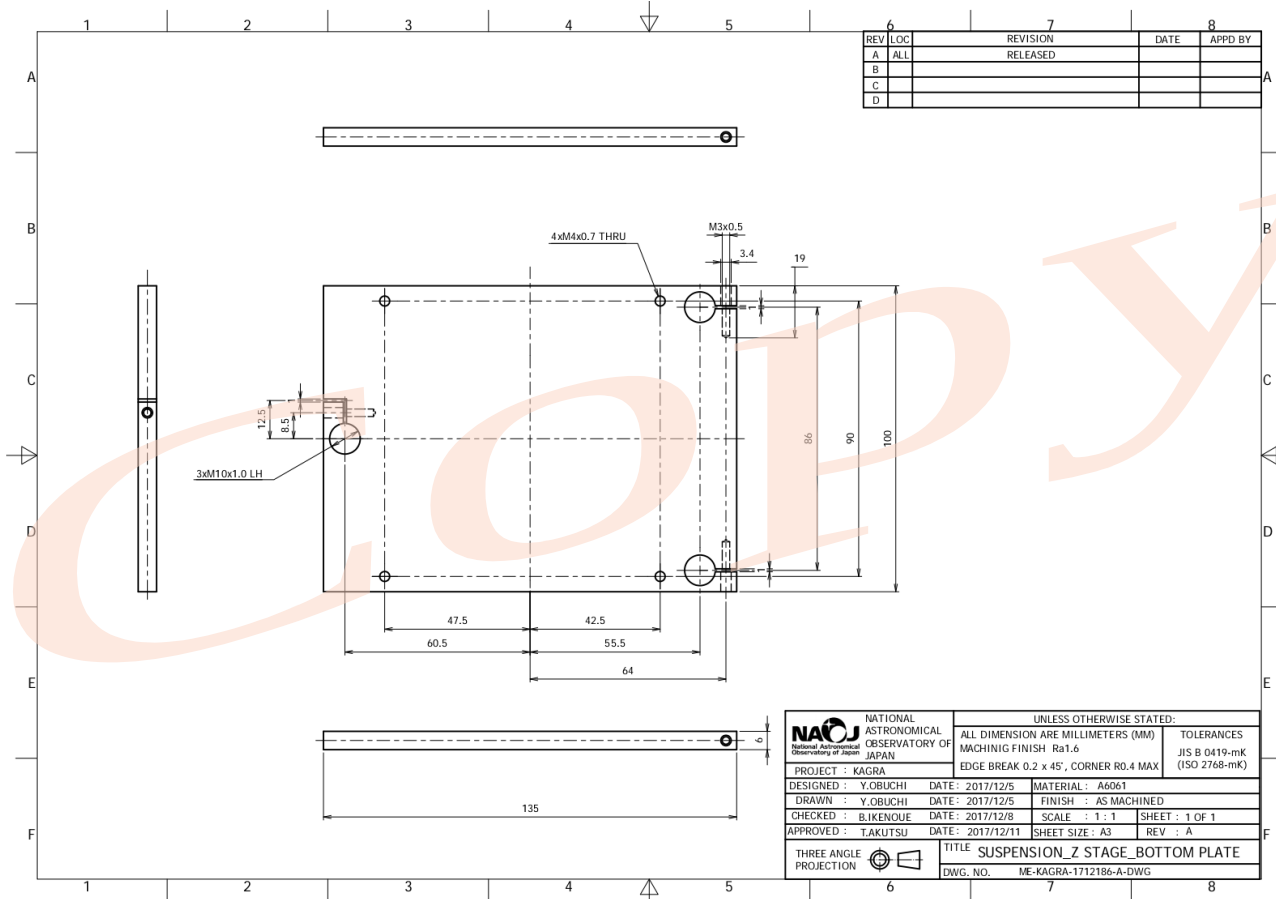
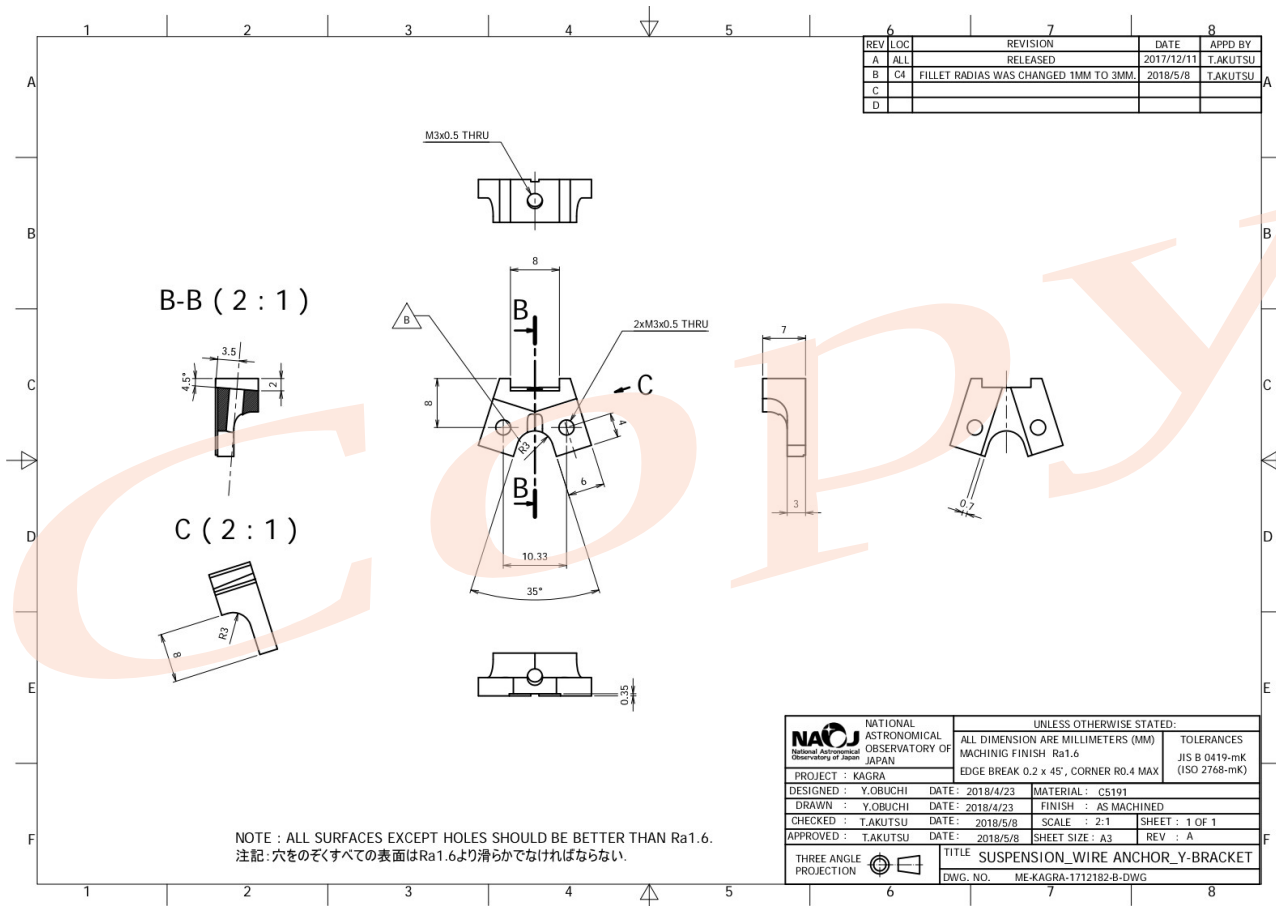

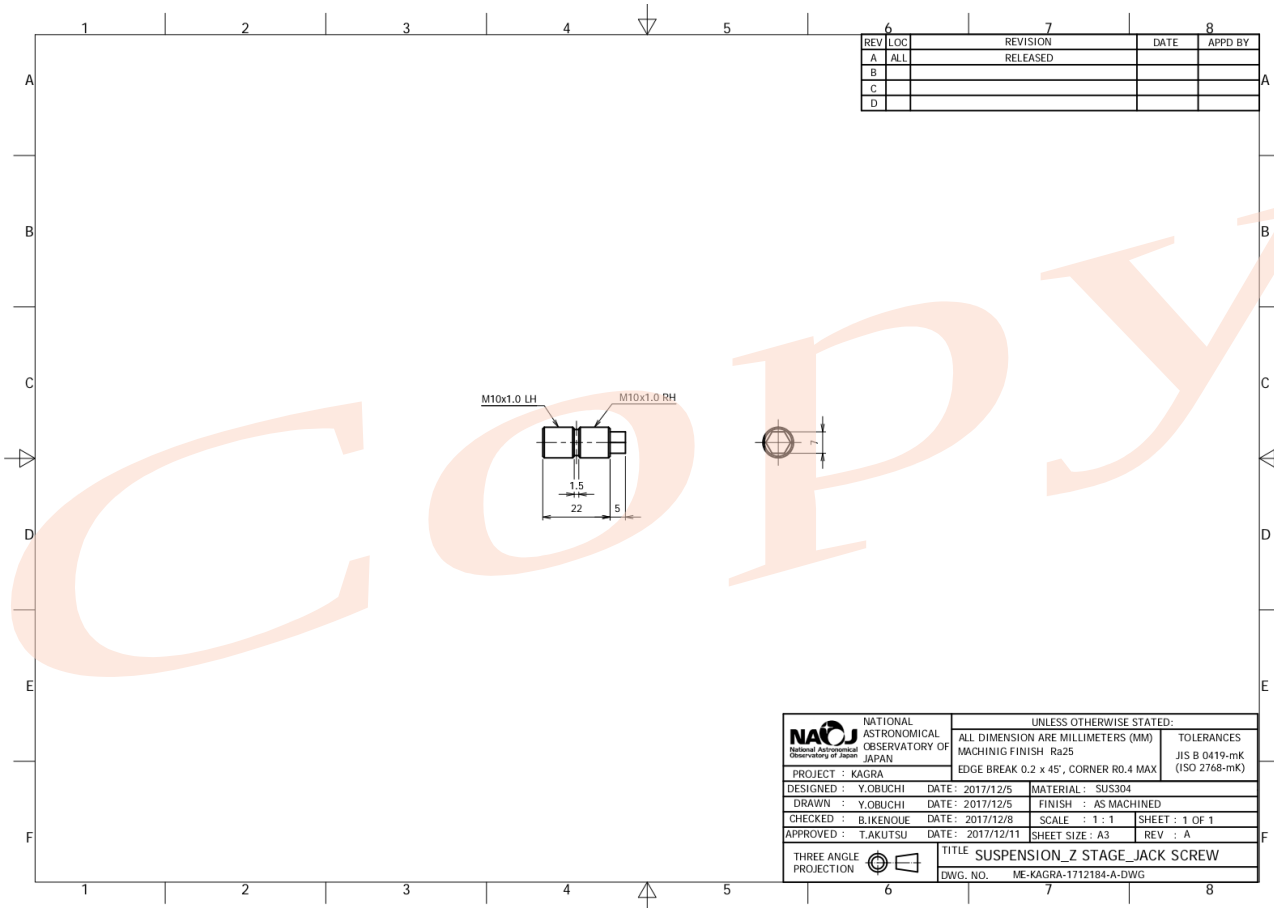

REV	LOC	REVISION	DATE	APPD BY
A	ALL	RELEASED		
B				
C				
D				

NATIONAL ASTRONOMICAL OBSERVATORY OF JAPAN National Astronomical Observatory of Japan	UNLESS OTHERWISE STATED:	
	ALL DIMENSION ARE MILLIMETERS (MM) MACHINING FINISH Ra25	TOLERANCES JIS B 0419-mK (ISO 2768-mK)
PROJECT : KAGRA	EDGE BREAK 0.2 x 45°, CORNER R0.4 MAX	
DESIGNED : Y.OBUCHI	DATE : 2017/12/5	MATERIAL : SUS304
DRAWN : Y.OBUCHI	DATE : 2017/12/5	FINISH : AS MACHINED
CHECKED : B.IKENOUE	DATE : 2017/12/8	SCALE : 1 : 1 SHEET : 1 OF 1
APPROVED : T.AKUTSU	DATE : 2017/12/11	SHEET SIZE : A3 REV : A
THREE ANGLE PROJECTION	TITLE SUSPENSION_Z STAGE JACK SCREW	DWG. NO. ME-KAGRA-1712184-A-DWG

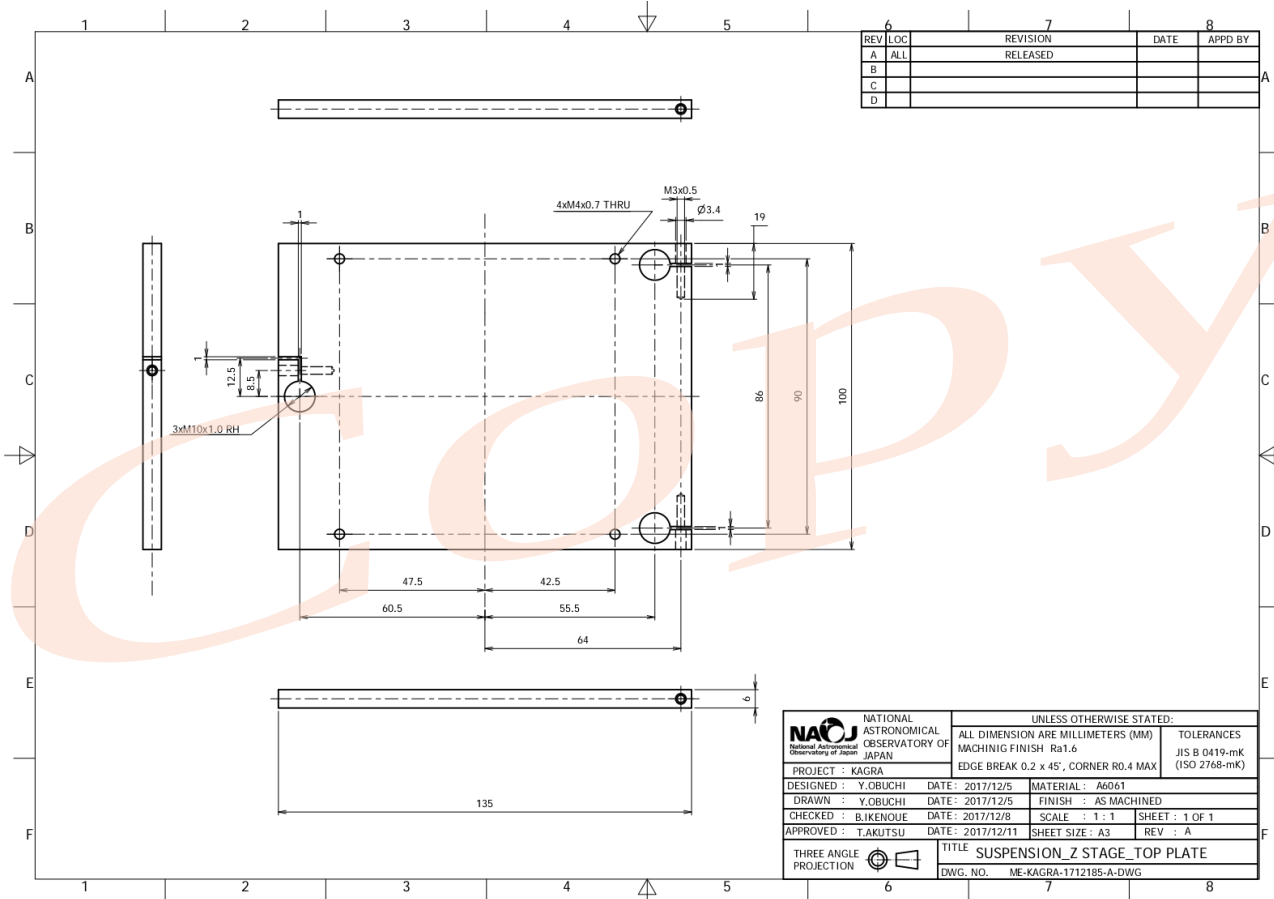

REV	LOC	REVISION	DATE	APPD BY
A	ALL	RELEASED		
B				
C				
D				

NATIONAL ASTRONOMICAL OBSERVATORY OF JAPAN National Astronomical Observatory of Japan	UNLESS OTHERWISE STATED:	
	ALL DIMENSION ARE MILLIMETERS (MM) MACHINING FINISH Ra1.6	TOLERANCES JIS B 0419-mK (ISO 2768-mK)
PROJECT : KAGRA	EDGE BREAK 0.2 x 45°, CORNER R0.4 MAX	
DESIGNED : Y.OBUCHI	DATE : 2017/12/5	MATERIAL : A6061
DRAWN : Y.OBUCHI	DATE : 2017/12/5	FINISH : AS MACHINED
CHECKED : B.IKENOUE	DATE : 2017/12/8	SCALE : 1 : 1 SHEET : 1 OF 1
APPROVED : T.AKUTSU	DATE : 2017/12/11	SHEET SIZE : A3 REV : A
THREE ANGLE PROJECTION	TITLE SUSPENSION_Z STAGE TOP PLATE	DWG. NO. ME-KAGRA-1712185-A-DWG