

KAGRA Overview for Commissioning Workshop

Keiko Kokeyama

November 27, 2017

KAGRA Observatory, Kamioka

Contents

1. KAGRA Quick Overview

2. Input Optics Overview for Workshop

Optical Configuration and Suspensions

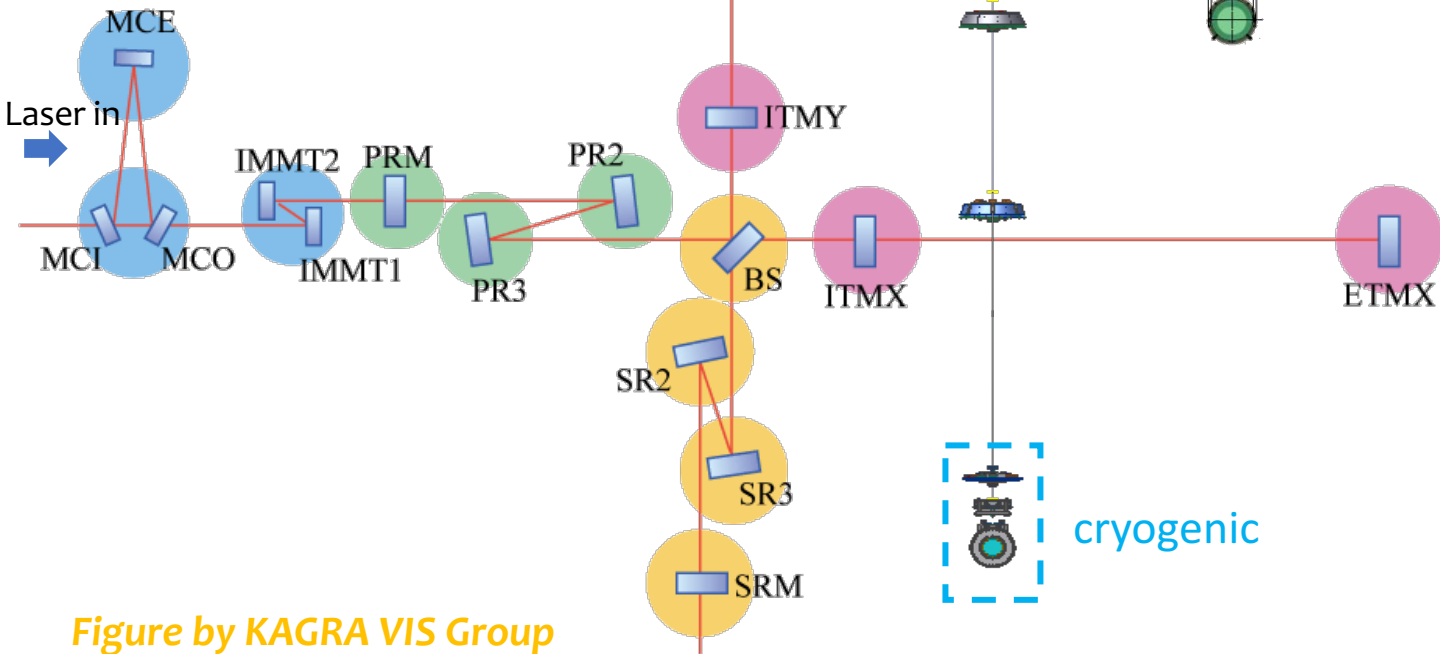

Type-A

Type-B

Type-Bp

Type-C

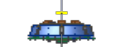
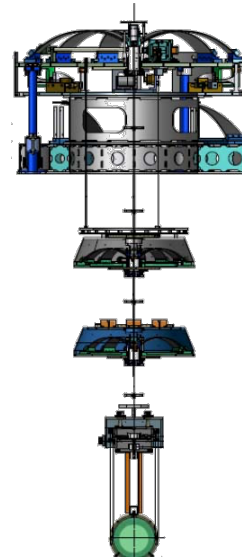
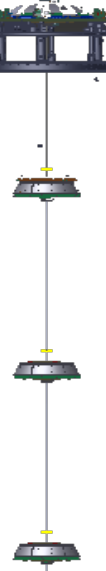
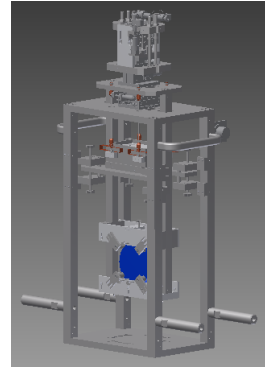
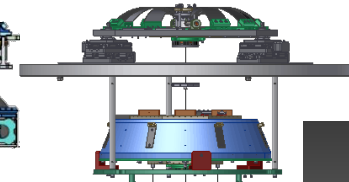
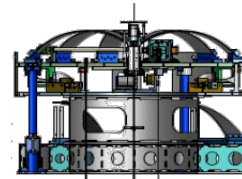
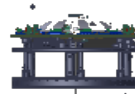

cryogenic

TypeA Requirement
 $1e-19m/rtHz$ @ 10HZ
 0.1 $\mu m/sec$

Figure by KAGRA VIS Group

Status of the Installations

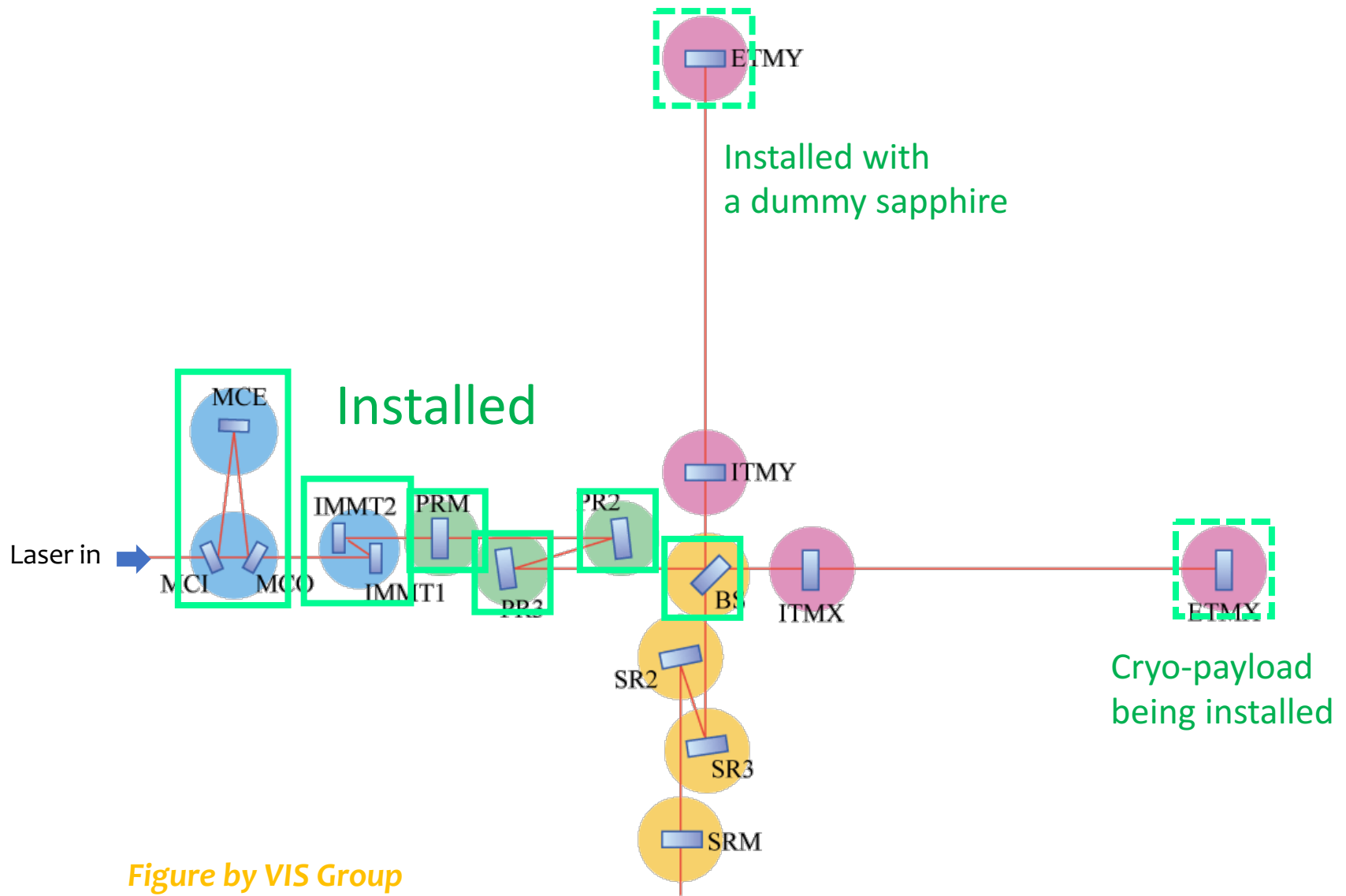

Figure by VIS Group

27 November, 2017

JGW-G1707450

FSY 2016-2017 : Phase I

Cryogenic Simple Michelson Interferometer

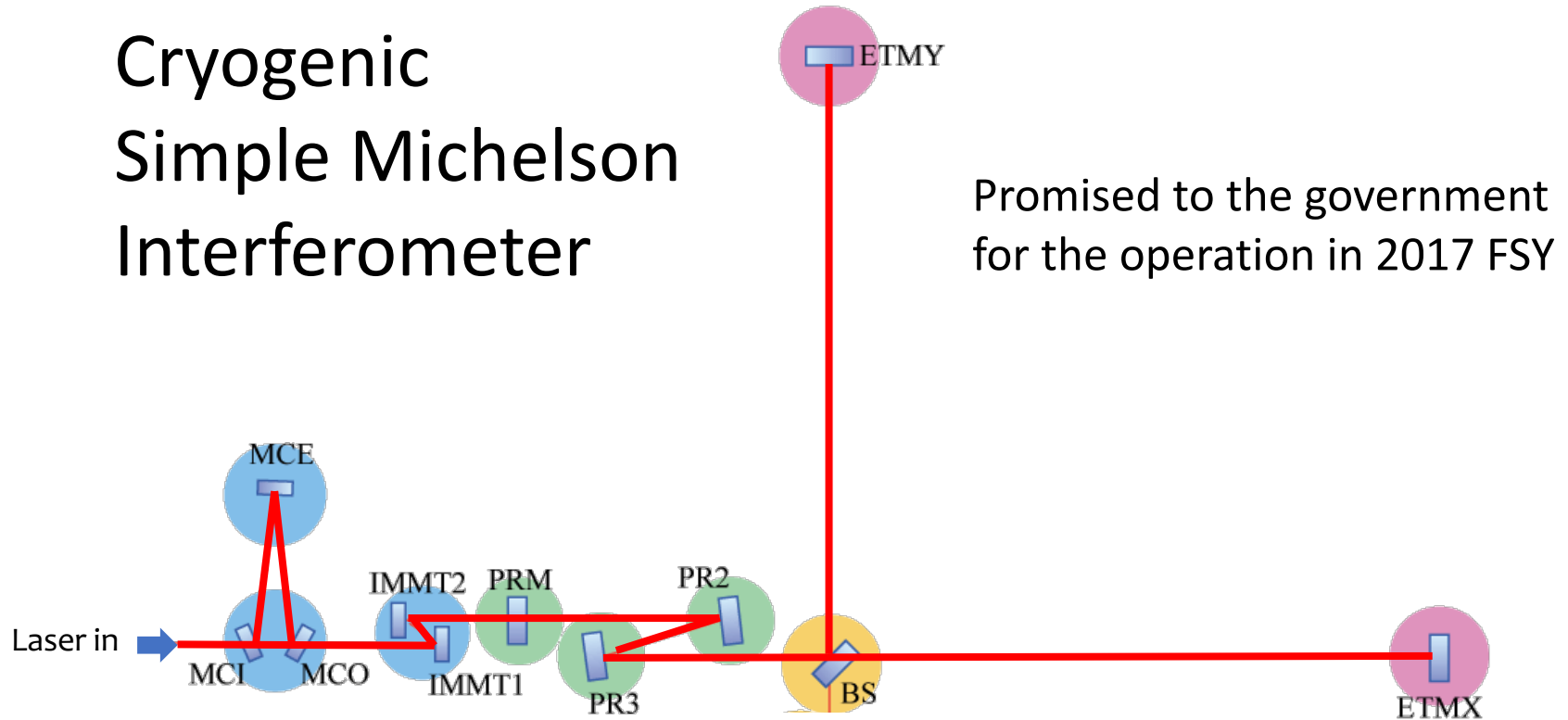

FSY 2018-2019? : Phase II

Full Configuration Interferometer

- Laser 40W max
- Output mode cleaner
- Green laser lock system

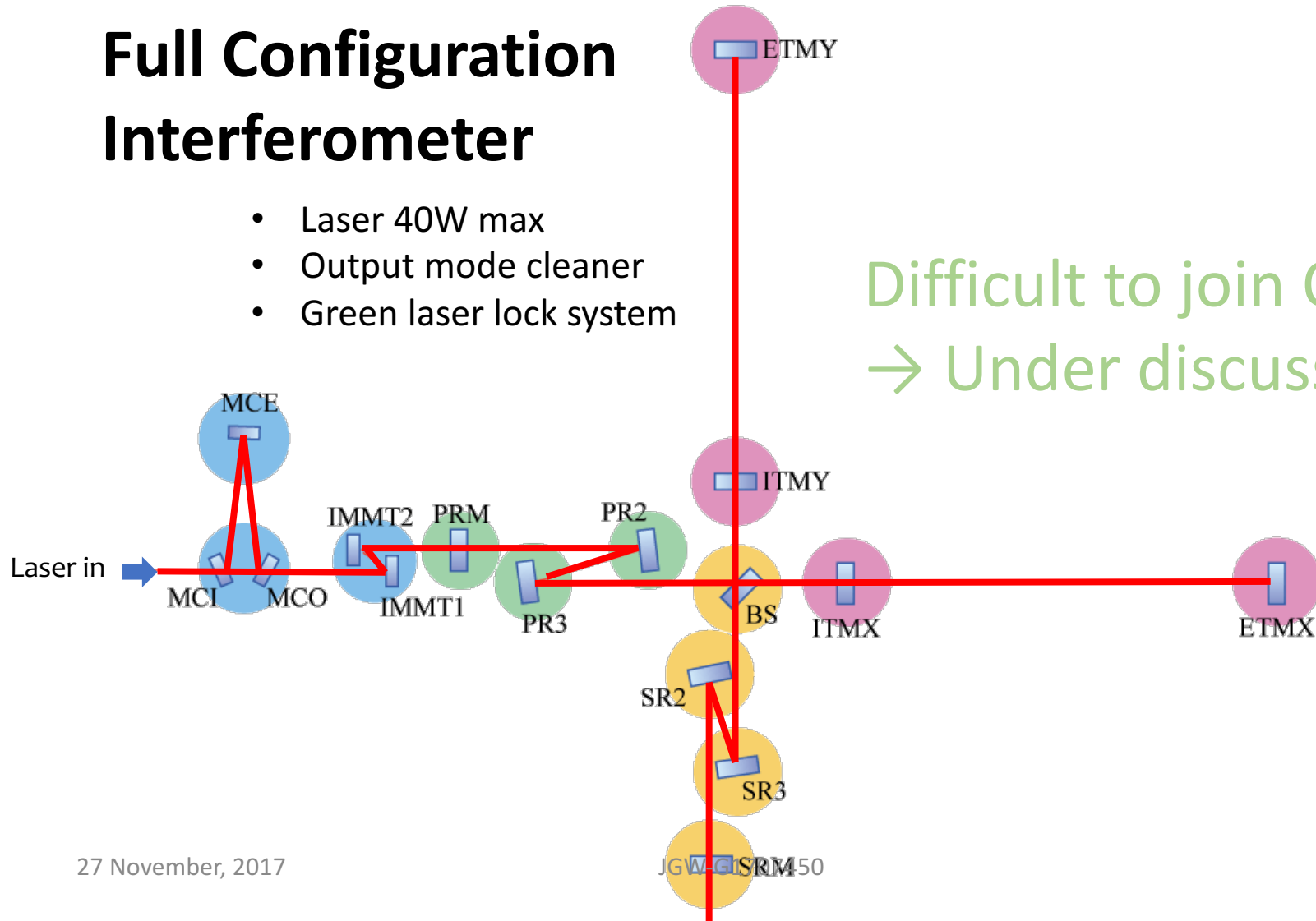

2020 - : Phase III

Full Configuration Interferometer

- Higher laser power (180W)

Noise Hunting

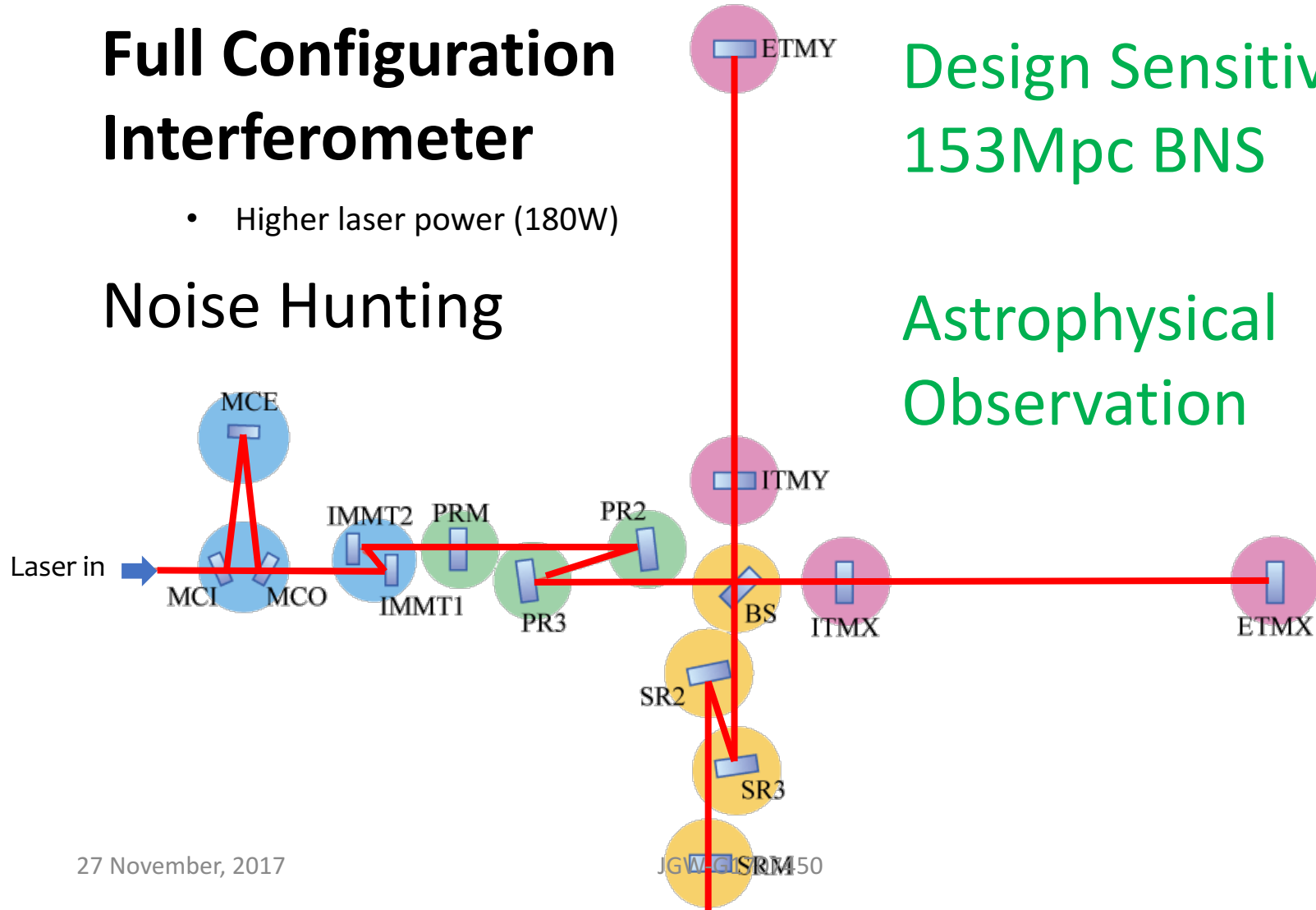

Design Sensitivity
153Mpc BNS

Astrophysical
Observation

BS



27 November, 2017

W-61-07450



8

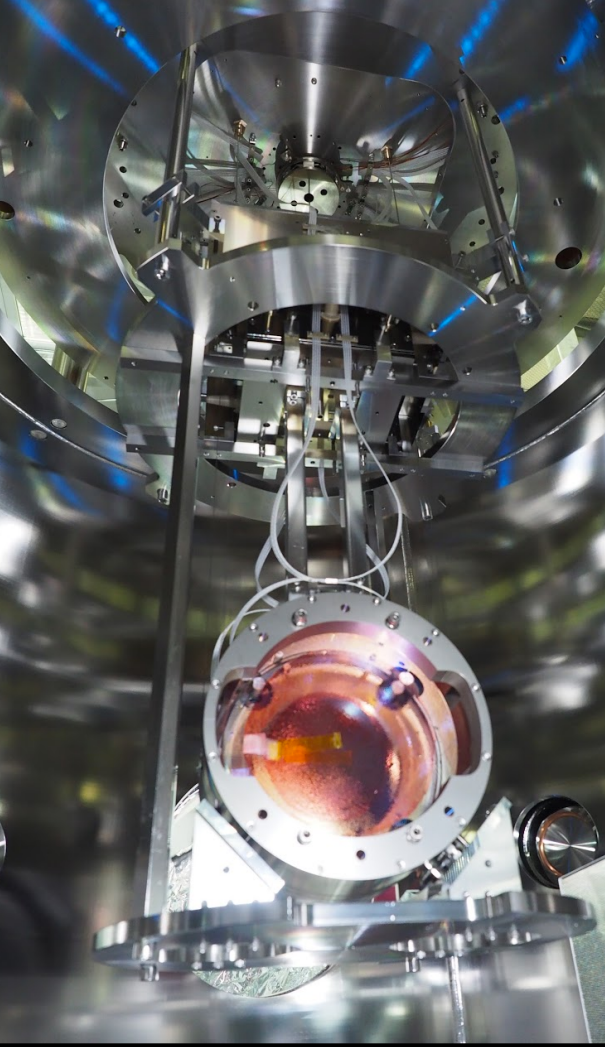

PRM KAGRA log 3446
(Oct 2017)

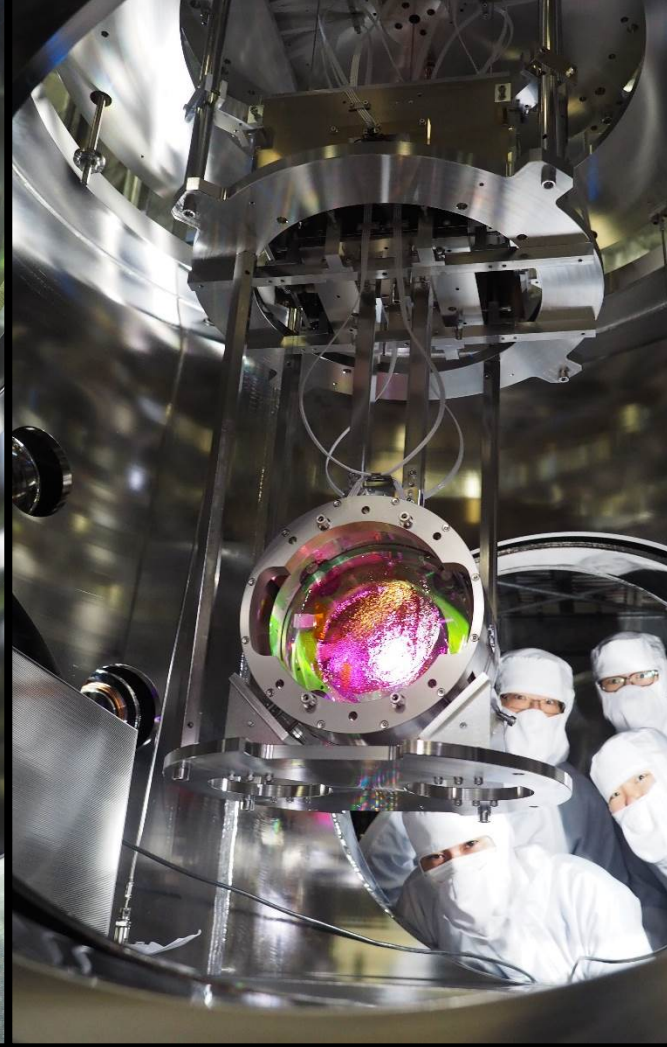

PR3 May 2017

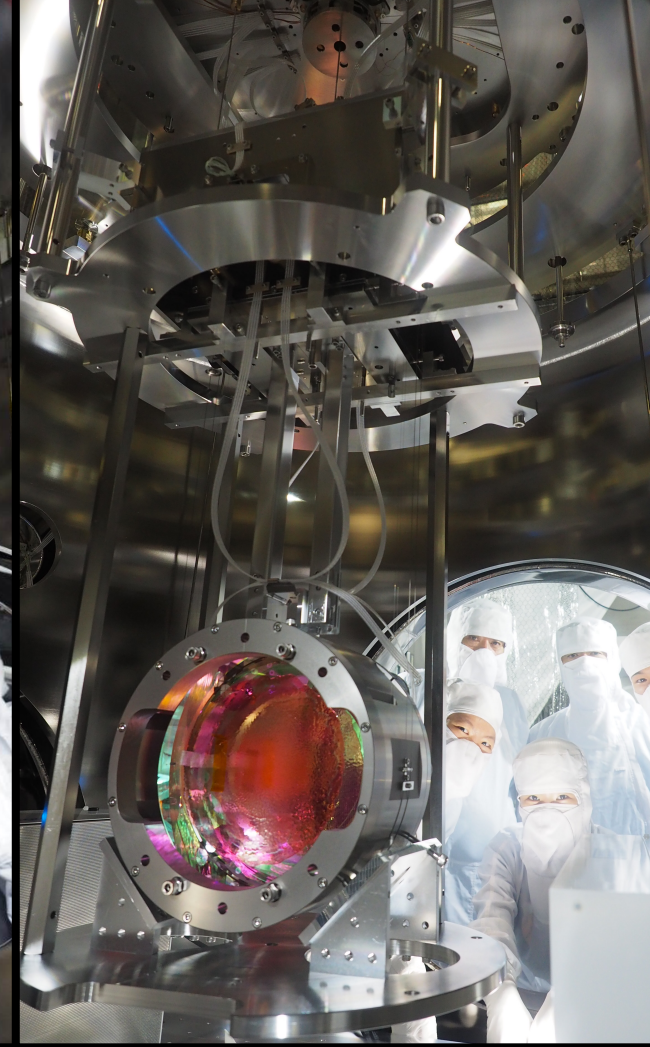

PR2 KAGRA log 3193
(Aug 2017)

All Power-recycling mirrors

Type-A Suspensions



27 November, 2017

Cryo-payload (Y end)

Tomaru, JGW-G1707020

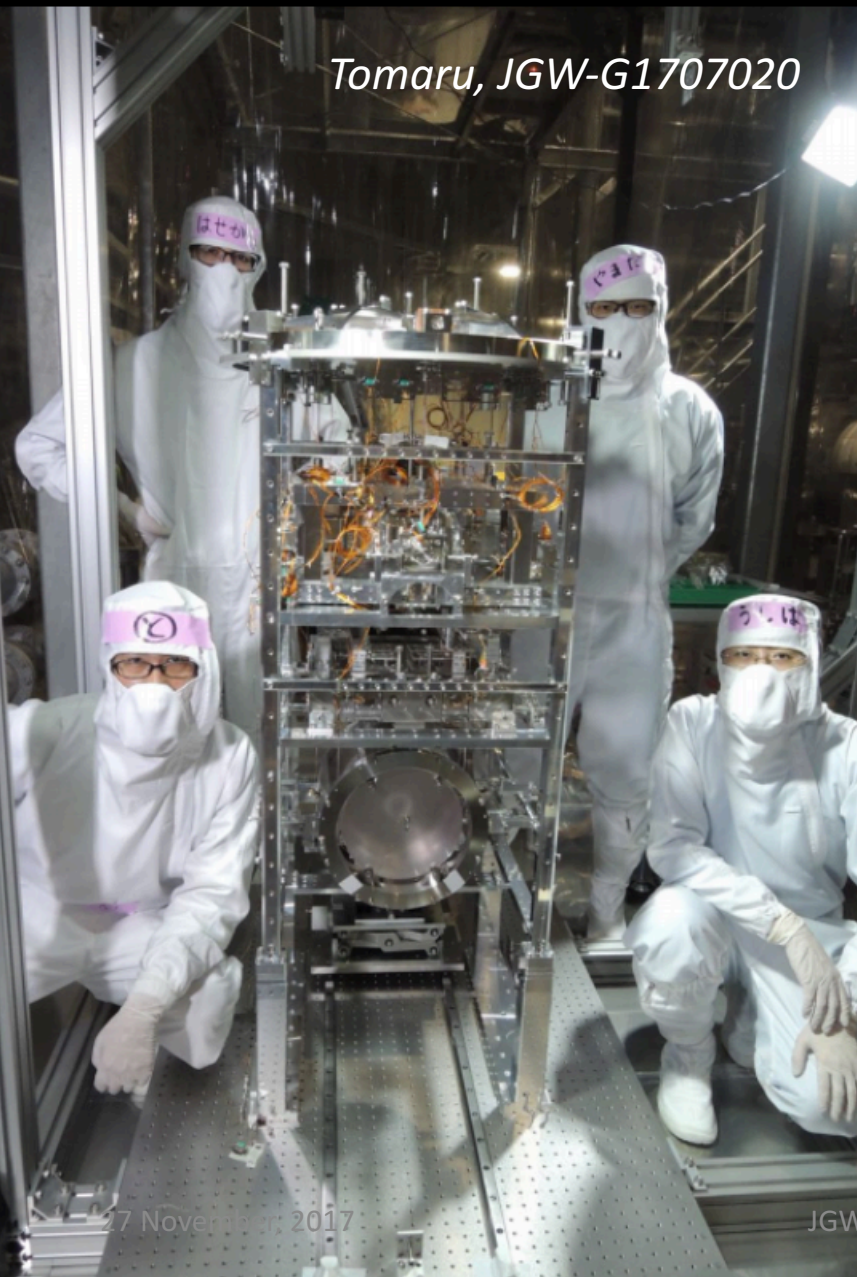

Kumar, JGW-G1706923

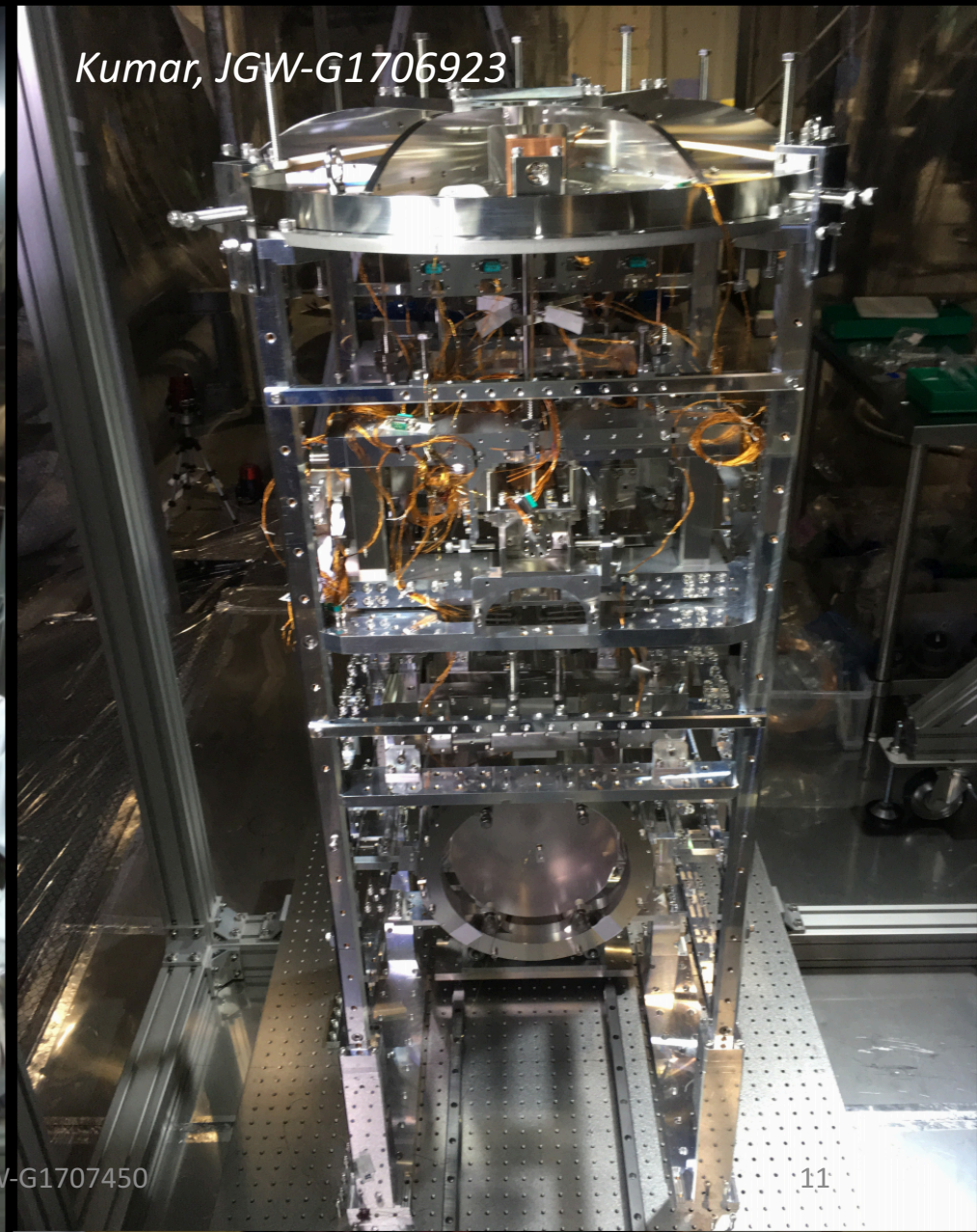

Cooling Test (Dummy Bulk)

Cooling Tests are Done at Yend – Aug 2017

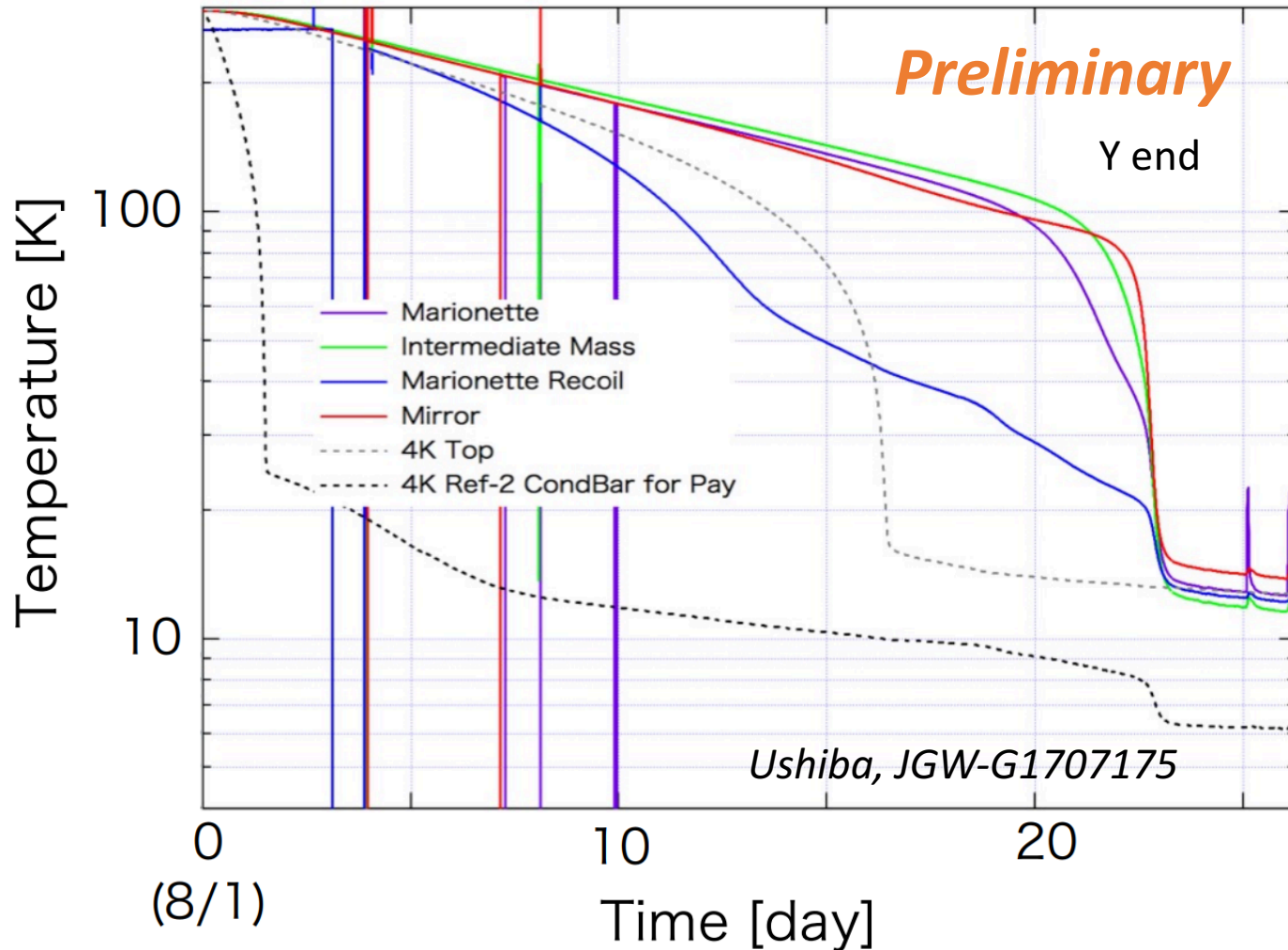

Status of the Sapphire Mirrors

- Y end cooling test – HCB-ed Sapphire bulk
- Xend Spare Mirror is at Toyama University (bonding lab), HCB-ed 4 weeks ago. Strength test started.
- Real mirrors will be delivered soon
- In phase-1, the spare mirrors will be cooled down
- Real mirrors will be installed in (before) phase-2

To be updated from Yamaguen

Possible Topics for this Workshop

1. PEM injection
2. Adaptive Feedforward
3. IMC ASC Commissioning

Using only the "working system" in KAGRA,
PSL and the input mode cleaner

PSL (Phase-1)

Laser

RefCav

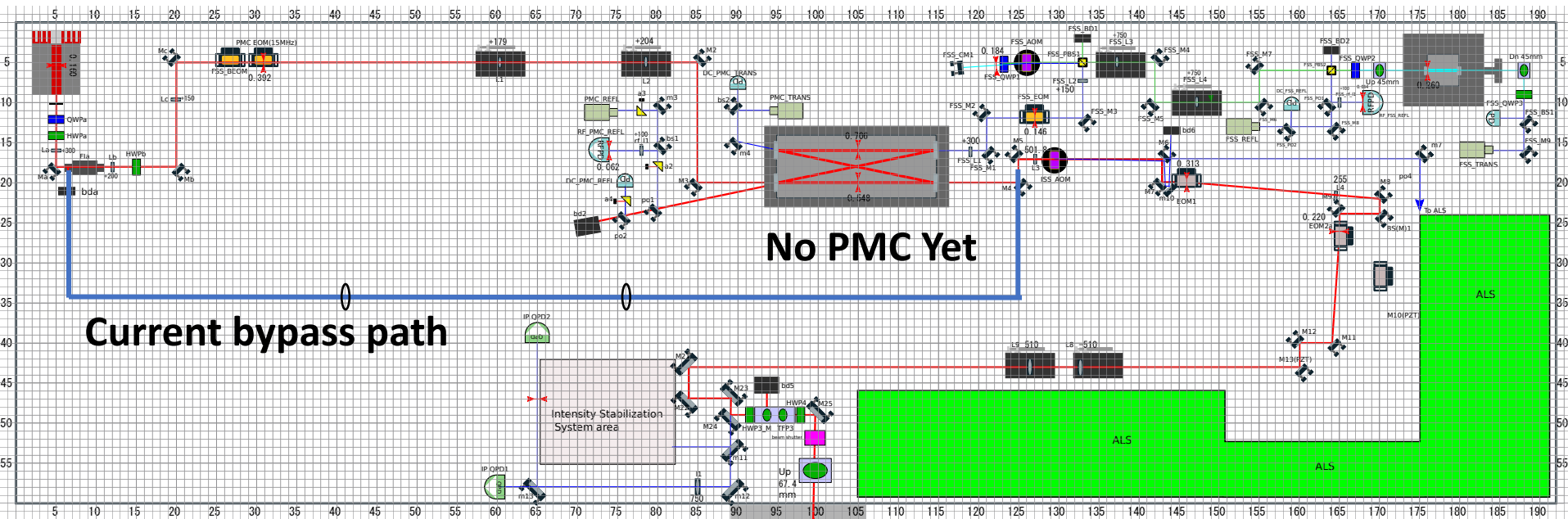

- ISS is coming soon
- PMC is delivered soon

To IMC

Input Mode Cleaner

Round trip: 53.3m
Finesse: ~ 500 (S-pol)

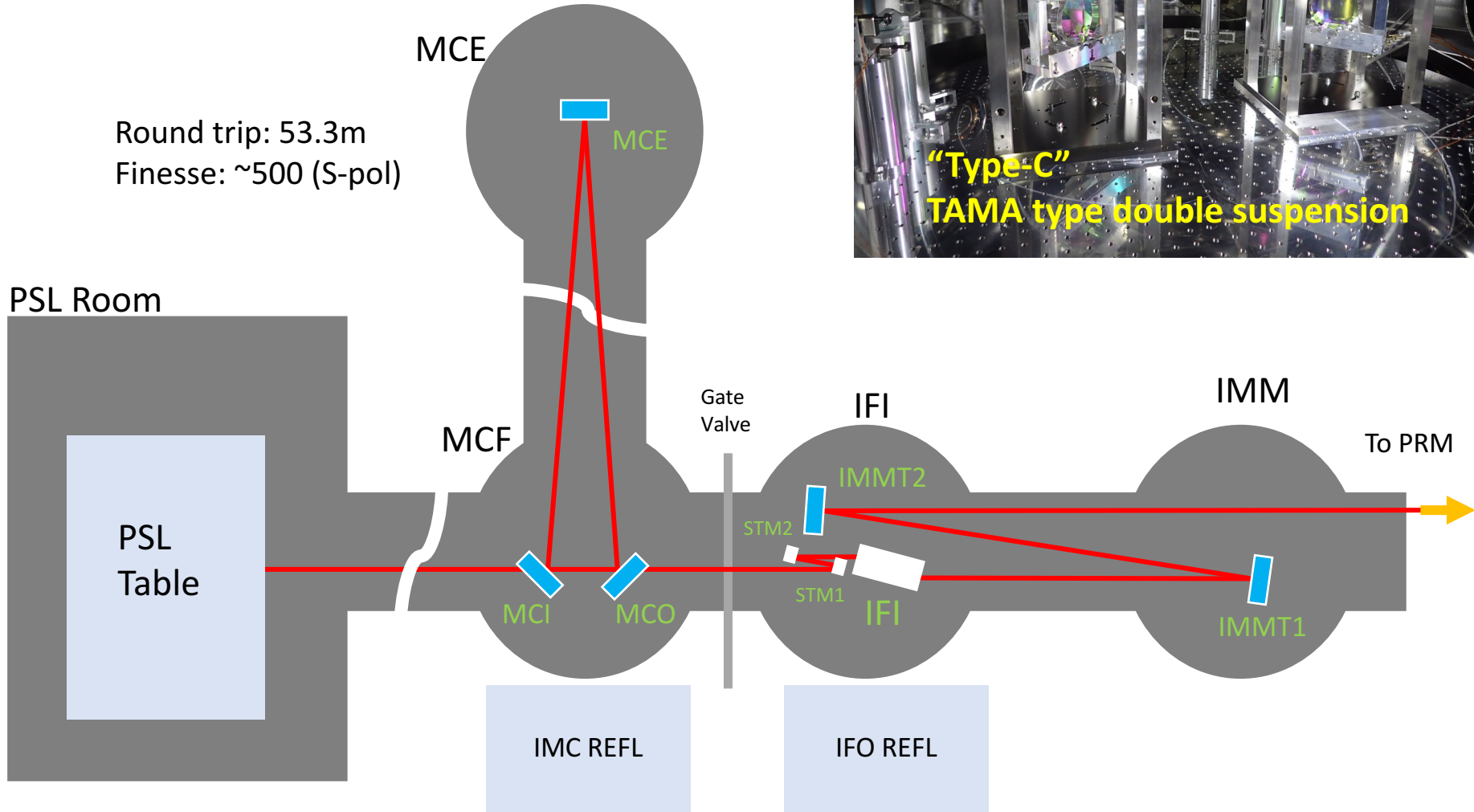

Optical Parameters

See,

<http://gwwiki.icrr.u-tokyo.ac.jp/JGWwiki/KAGRA/Subgroups/IOO/OptParam>

Control Topology

See, JGW-G1707105 by Nakano and klogs

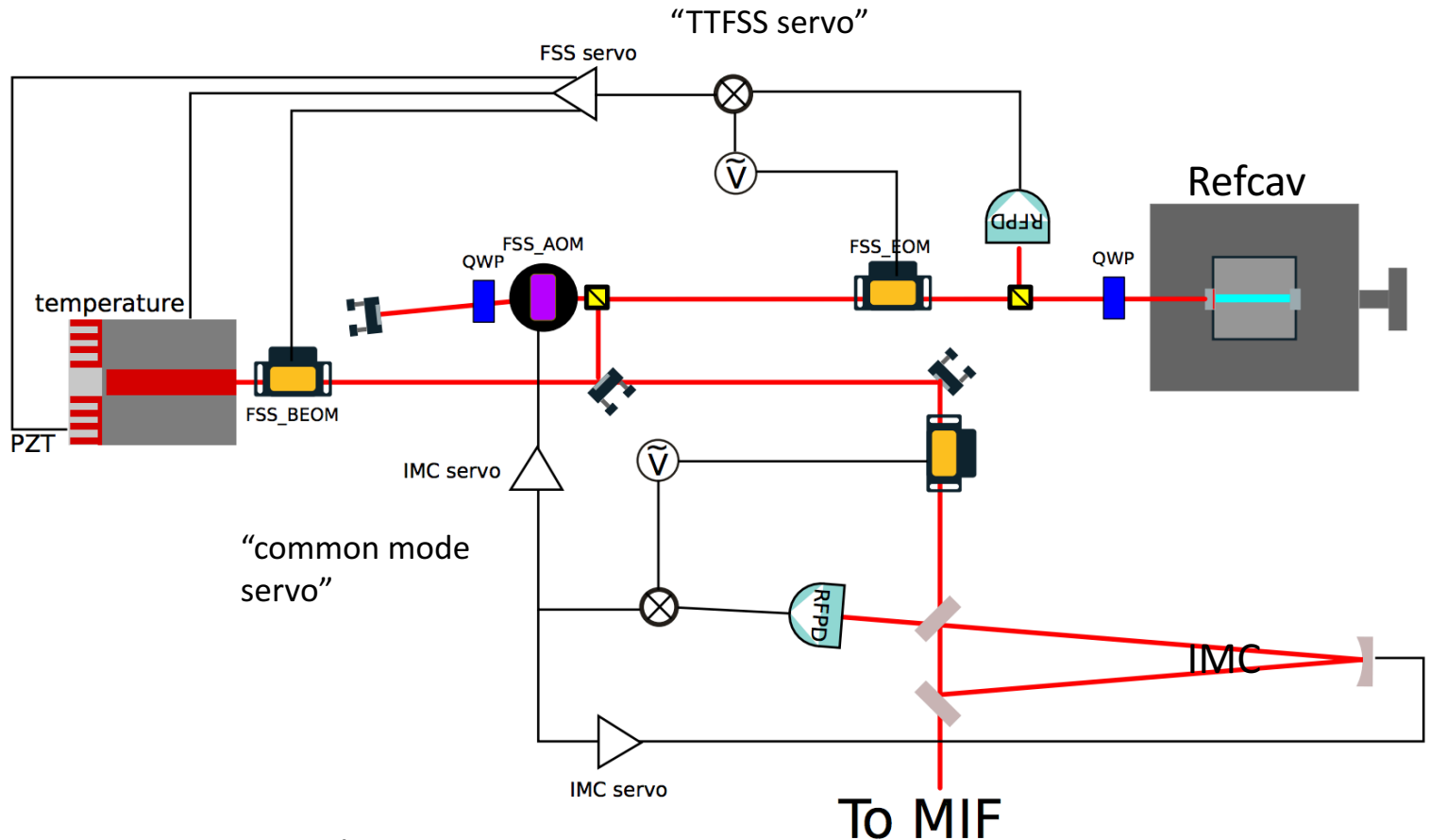

FSS:
cross over 20kHz (laser PZT/EOM), UGF 120kHz

IMC:
cross over 3Hz (AOM/Suspension), UGF 30kHz

Available Angular Sensors

Angular control doesn't work well: see many klog entries

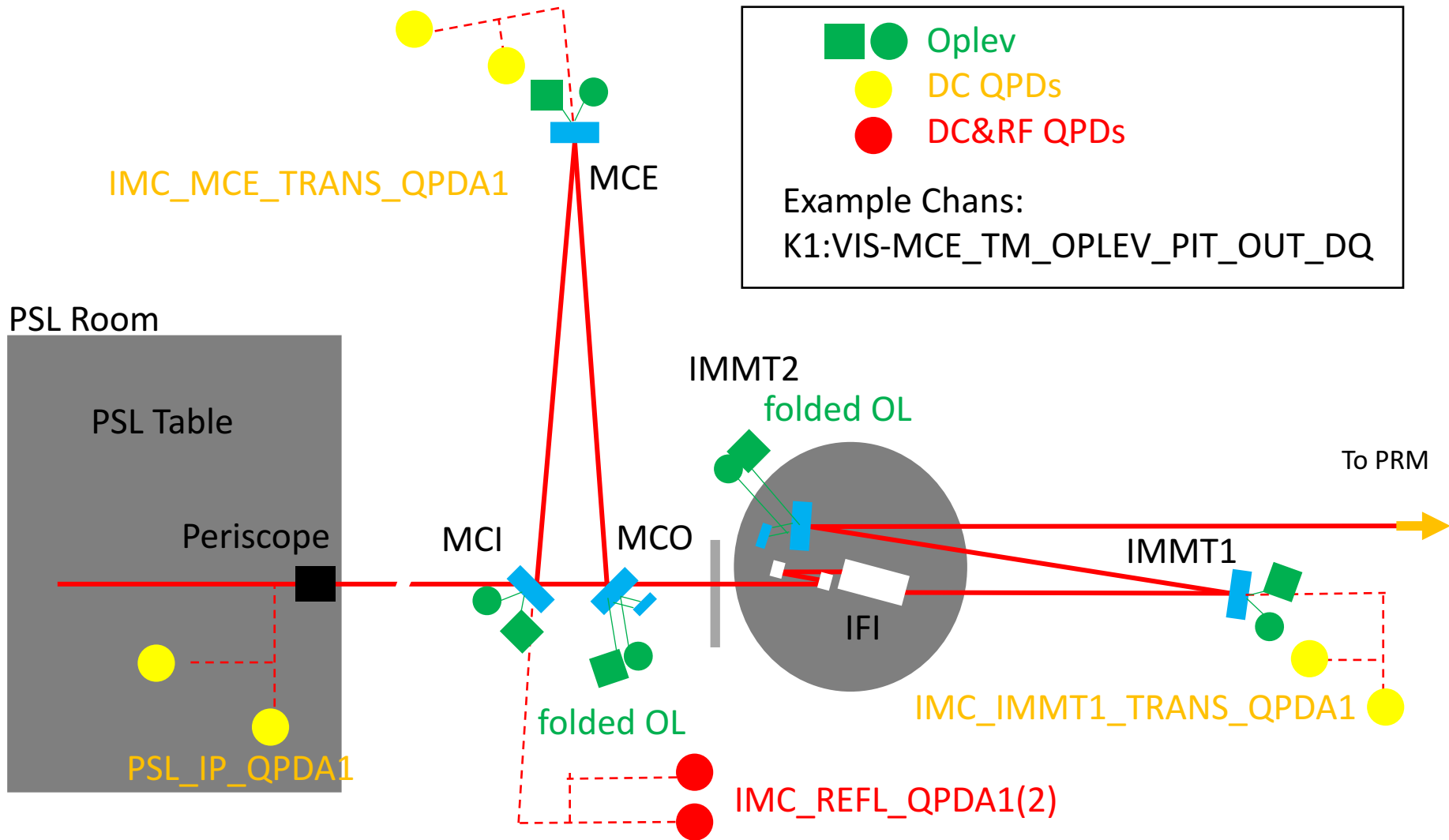

Resources

- **klog**

- <http://klog.icrr.u-tokyo.ac.jp/osl/>

- **KAGRA wiki**

- <http://gwwiki.icrr.u-tokyo.ac.jp/JGWwiki/KAGRA>

- **Bugzilla (ICRR network internal)**

- <http://172.16.33.20/bugzilla/>

- **JGW-document**

- <https://gwdoc.icrr.u-tokyo.ac.jp/JGWDoc/Welcome.html>