

Installation of OpLevs in KAGRA - Manual -

Simon Zeidler

For the Japanese version, please see here: []

In this manuscript, “OpLev” is used to describe both the regular (tilt-sensing) and length-sensing OpLev. Although the term “OpLev” literally comes from optical lever, meaning it is for tilt-sensing, we use it thus in a more general way.

1. Preparations

1.1. List of Materials

Independent on the individual configuration, the following items and their least quantity are needed:

- 2 x Breadboard
Standard breadboard for AOS is made of black-coated Aluminum(?) and has a size of 300 x 400 x 15(?) mm
- 2 x Pylons
Individual height for different systems but both pylons need to have equal heights (exception: BS)
<https://gwdoc.icrr.u-tokyo.ac.jp/cgi-bin/private/DocDB/ShowDocument?docid=2974>
- 4-6 x Anchor Clamps (+ screws)
Heavy steel-clamps with a blue stripe painted on them, fixing the pylons to the ground via anchor holes (2-3 per pylon + M20(?) screws)
- 6 x Screw Adapter for Breadboard (+ screws)
4 x big and 2 x small adapters are required. The adapters are fixed to the breadboard (with M6x15(?) screws) so that their position correlates to the M12 screw holes on top of the pylons
The assembly of the pylons and the breadboard is descriptively drawn here:
<https://gwdoc.icrr.u-tokyo.ac.jp/cgi-bin/private/DocDB/ShowDocument?docid=3317>
- 1 x OpLev laser source (+ clamp and power supply)
The clamp is fixed to the top of the breadboard holding the laser-source-box tight to it

- 1 x Collimator-Holder Assembly (+ pillar-clamp)
The holder is to be assembled separately by using a pillar (9954-M) and two spacer (9950_3.3 and 9950_6.4) from “Newport/New Focus”, a 1 inch mirror holder (Thorlabs KM100T), and a collimator-holder (Thorlabs AD8F)
- 1 x Collimator
The collimators are delivered in three different focal lengths and come together with a connecting-fiber which is to be plugged into a fiber-connector together with the fiber coming from the laser-source-box
The fiber connector is to be fixed onto the breadboard (with M6 screws)
For a list of the available types of collimators, see the table on page number 2 on the bottom left:
<https://gwdoc.icrr.u-tokyo.ac.jp/cgi-bin/private/DocDB/ShowDocument?docid=3565>
- 1 x Fiber Cleaner
- 2 x QPD Stages (1 x regular and 1 x LS type)
For the assembly, see below
- 1 x Beam Splitter
1 inch BBAR coated (Thorlabs BSW26)
- 1 x Lens
1 inch coated bi-convex lens F=300 (Thorlabs LB1779-A)
- 1-2 x Mirror
1 inch protected silver mirrors (Thorlabs PF10-03-P01-10)
- 1 x XY Translator Stage
1 inch diameter with micrometer drivers (Thorlabs ST1XY-S/M)
- 2-3 x Kinematic Mirror Mounts
1 inch (Thorlabs KM100)
- 2-3 x Centering Plate Mirror Mounts
(Thorlabs KCP1/M)
- 3-4 x Post Holder
40mm universal post holders (Thorlabs UPH40/M) + M6 screws for fixing the holders to the breadboard
- 3-4 x Posts
40mm long (Thorlabs TR40/M-P5)

1.2. Assembly of Components

1.2.1 Collimator-Holder

In the drawing below, the basic assembly of the collimator-holder is shown. The items are: 1 – mirror holder KM100T; 2 – collimator holder AD8F; 3 – Spacer 9950_3.3; 4 – Spacer 9950_6.4; 5 – Pillar 9954-M; 6 – M4x25 hex cap socket screw

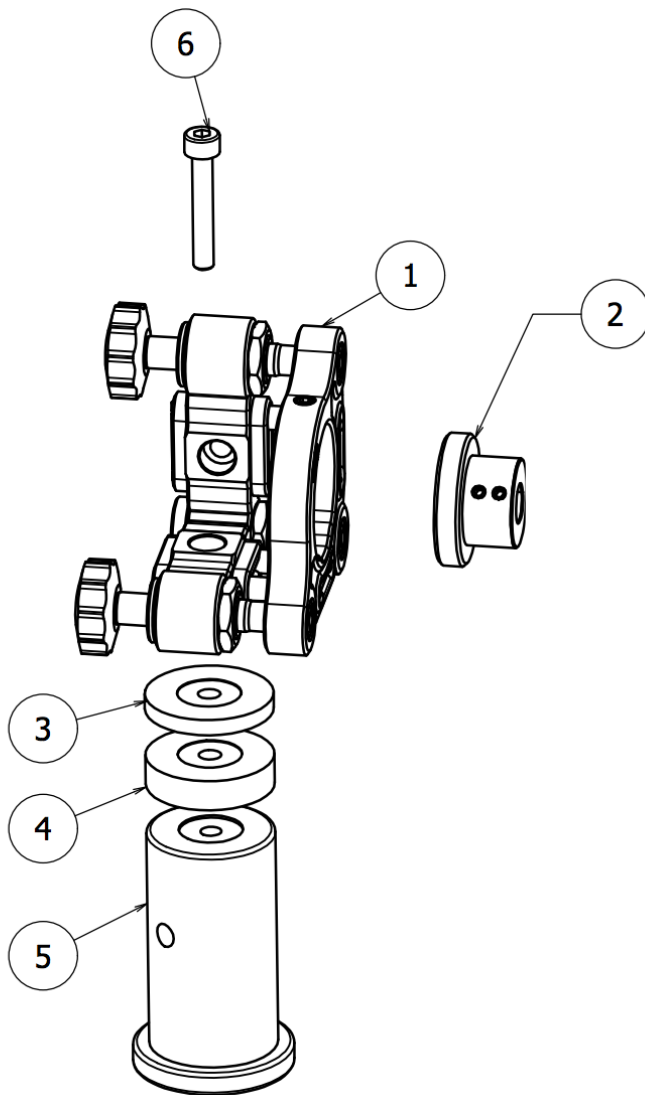

1.2.2 Regular QPD Stage

For the assembly of the regular QPD stage, we need the following additional items:

- QPD Circuit Board (1)
- Rectangular Spacer (2)
- Circular Spacer (3)
- x-Translator (4)
- z-Translator (5)
- Angular Holder (6)
- 12 x M4x6 Screws (7)
- 4 x M4x8 Screws (8)
- 4 x M4x12 Screws (9)
- Hexagonal Spacer Screws (10)
- Cup-Point Screws (11)

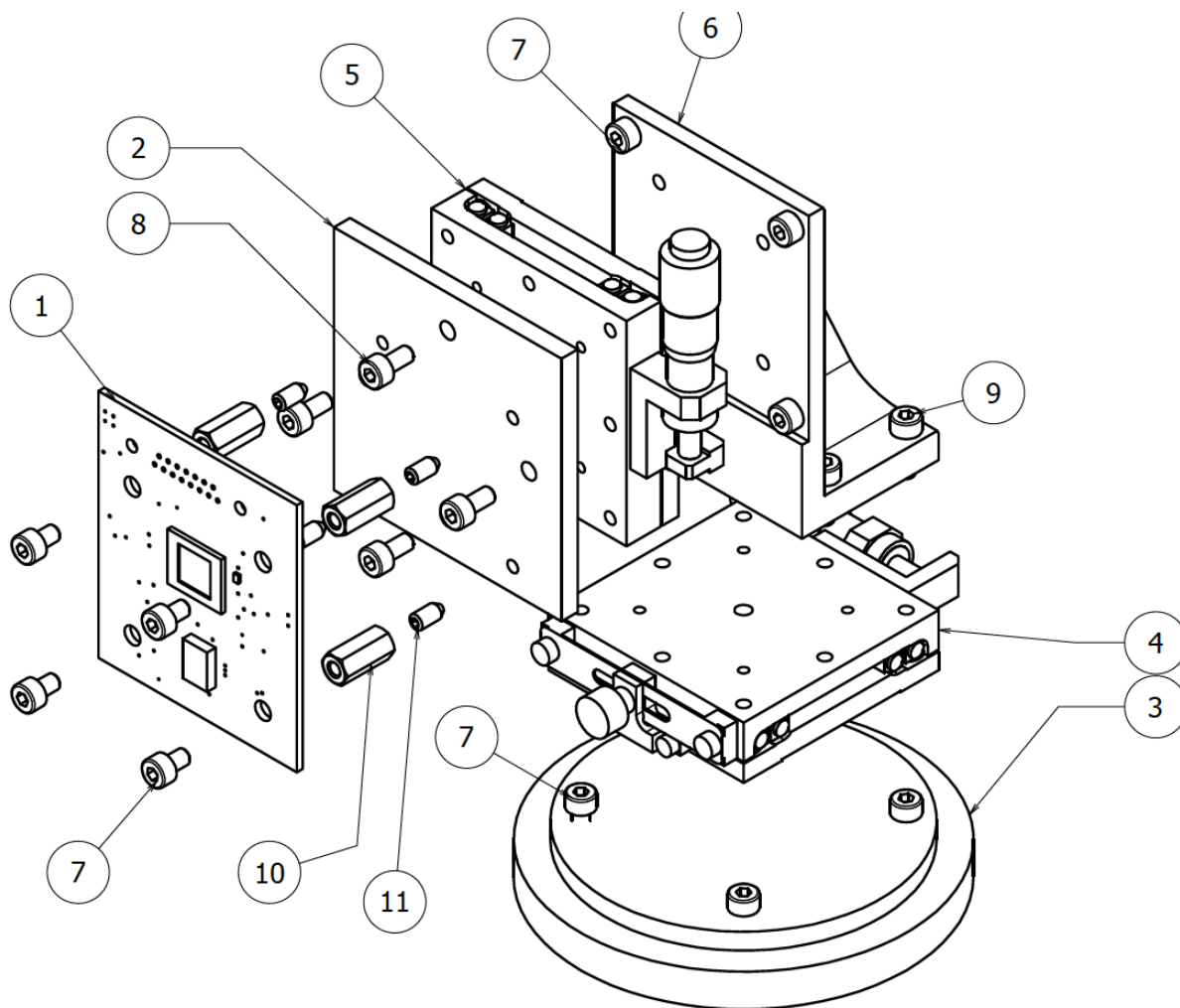

1.2.3 LS QPD stage

For the assembly of the LS QPD stage, we need the following additional items:

- QPD Circuit Board (1)
- Rectangular Spacer (2)
- Circular Spacer (3)
- x-Translator (4)
- z-Translator (5)
- Angular Holder (6)
- 12 x M4x6 Screws (7)
- 4 x M4x8 Screws (8)
- 4 x M4x12 Screws (9)
- Hexagonal Spacer Screws (10)
- Cup-Point Screws (11)

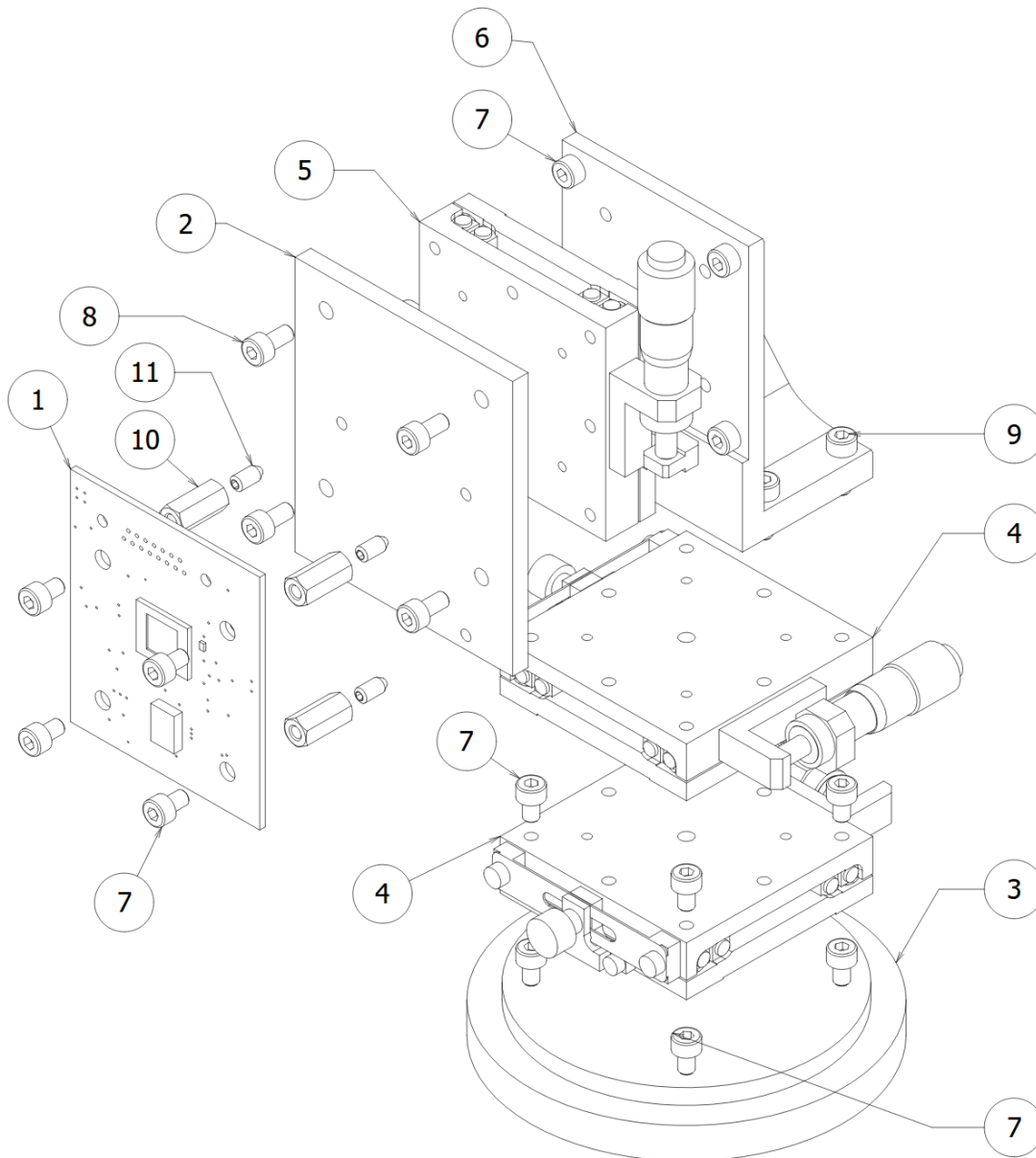

1.2.4 Beam-Splitter Holder Assembly

1. Set the beam splitter into the mirror holder and tighten the screw for fixing the mirror in its position
2. Fix the mirror holder with a M4x8 screw on the centering plate. Fix it so that the reflecting surface of the mirror is centered above the second screw-hole of the centering plate
3. Screw the post to the centering plate
4. Set the hole assembly into the post holder and tighten the fixing-screw on its side

1.2.5 Mirror Holder Assembly

Follow the same steps as for the beam splitter but use a protected silver mirror instead of the beam splitter.

1.2.6 Lens Holder Assembly

1. Take the XY-translator stage and unscrew one of the ring-holders from the center-hole
2. Insert the lens into the center-hole
3. Screw the ring-holder back into the center-hole and tighten it gently so that the lens is fixed in the center of the hole
4. Screw the post to the translator
5. Set the hole assembly into the post holder and tighten the fixing-screw on its side

2. Setup

2.1. Light-Source

Usually, the light-source and the QPD stages are placed on different breadboards. The only exception for this configuration is PR2 (see also here: <https://gwdoc.icrr.u-tokyo.ac.jp/cgi-bin/private/DocDB/ShowDocument?docid=5788>), where we have space for only one breadboard.

1. The light-source-box and the collimator-holder assembly are to be placed on the breadboard and should be fixed (temporarily).
2. Fix a fiber-connector to the breadboard so that it can easily be reached by the fibers of both the collimator and the light-source-box

Important:

Do not bend the fibers too much!! They have a core of glass inside!

Keep them slightly enrolled with a circular diameter of more than 10cm!

3. Remove the caps from both the connector and the first fiber you want to connect
4. Take a fiber cleaner and streak the end of the bare fiber (a white, specially formed cap) on one of the cleaner's tissue openings only once in one direction. Then, do it in the other direction on the other tissue opening
5. Once the fiber-end is cleaned, insert it into the connector. Take care that the flute is properly directed to the respective notch on the connector
6. Repeat steps 3 to 5 for the second fiber
7. Connect the light-source-box with the power supply and activate the light-source
8. Align the collimator-holder assembly so that the beam is properly injected through the viewport and toward the mirror inside the chamber. The beam should hit the center of the mirror and the reflected beam should go through the opposite viewport to reach the QPDs
9. fix both the light-source-box and the collimator-holder assembly to the breadboard

2.2. QPD Breadboard

2.2.1 Regular (Tilt) QPD

The regular – meaning tilt-sensing – OpLev is simply being set by placing the QPD stage in the out-coming beam of the viewport on the opposite side of the light-source-viewport. Its meaning is to sense mainly the yaw of the mirror relative to the environment outside the chamber. So, basically, as longer the path of the reflected beam (“lever”) is, as more sensitive the regular QPD will become.

However, there are things to be kept in mind also here:

- Put the QPD close to a position where the beam has the collimated focus. A focused beam is increasing the signal to noise ratio
- Keep space for additional items from the LS QPD
- fix the QPD stage with a clamp to the breadboard. Use the structure of the circular spacer for that

2.2.2 LS QPD

The correct setup of the LS QPD is strongly related to the individual properties of each chamber and the needs of the VIS group. A summary with all the parameters needed for a LS OpLev setup (especially the distance of the QPD to the beam splitter for each mirror) and the theoretical background are given in <https://gwdoc.icrr.u-tokyo.ac.jp/cgi-bin/private/DocDB/ShowDocument?docid=5788>. The main task for the LS QPD is to sense only the movement of the beam's position which is not related to a yaw movement but to a shift of the mirror along the path of the main beam of the interferometer.

Points to be kept in mind are:

- Set the beam splitter in between the exit-viewport and the regular QPD
- Set the XY-translator stage with the lens right after the beam splitter, so that the beam is passing the lens in its center. Use the space wisely!
- Fix the holders of both the beam splitter and the lens to the breadboard
- Adjust the XY-translator stage for a further centering of the beam on the lens. Use the micrometer screws on the translator
- Depending on the size of the breadboard and the distance the LS QPD should have from the lens, one needs to place probably a folding mirror on the breadboard to keep the beam on the area covered by the breadboard. For that purpose, place the respective silver-mirror with its holder on a suitable position

Important: There are already drawings in the JGW document server about the best placing of all items for each mirror (author: Simon Zeidler)!

- Place the LS QPD stage in the beam's path in the same way as described for the regular QPD stage, but in any case: mind the correct distance to the lens as given in the document <https://gwdoc.icrr.u-tokyo.ac.jp/cgi-bin/private/DocDB/ShowDocument?docid=5788>
- (→ For further adjusting the distance, a second x-translator has been implemented on the LS QPD stage)

After the QPDs are set, they can be connected to the Dsub-cables in order to receive a signal. For all the QPDs, then, the fine-tuning can start, meaning that the position of the beam may be centered by using the respective data-models where an image of the position is created on the PC. These images are very useful (not to say necessary) for a good position tuning.

3. Adjustment