

A photo sensor to monitor the motion of the recoil mass during the suspension assembly

Since we do not have OSEM sensors on the mirrors, we do not have any local sensor for the last stage until the suspension system is installed into the chamber, where the length sensing OpLev can be used.

This document describe a photo sensor to monitor the recoil mass motion during the assembly work so that we can measure transfer functions to the last stage of the suspension to confirm nothing is touching

Mechanical Design

Overview of the system

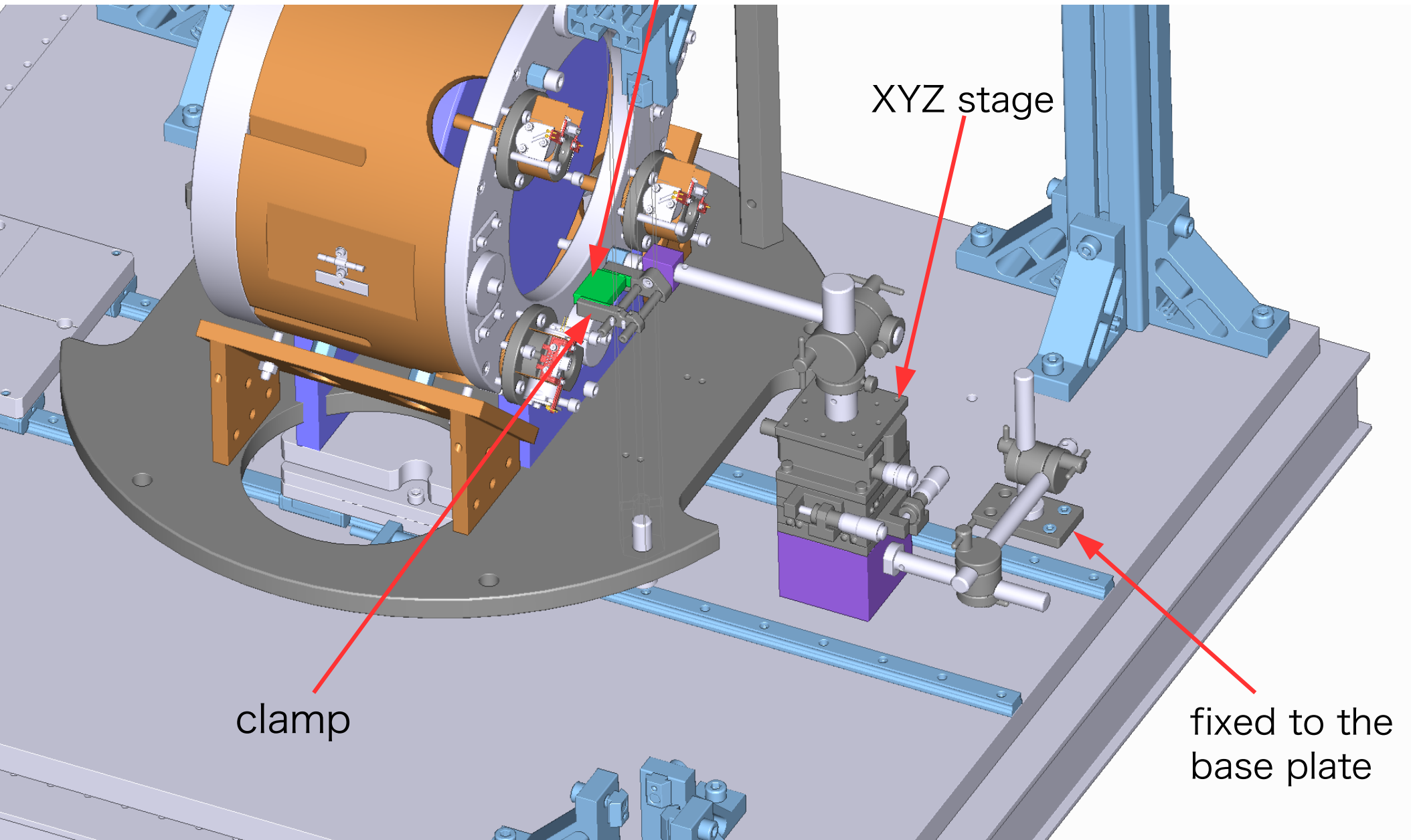

photo sensor

XYZ stage

clamp

fixed to the base plate

Purple colored parts need to be manufactured

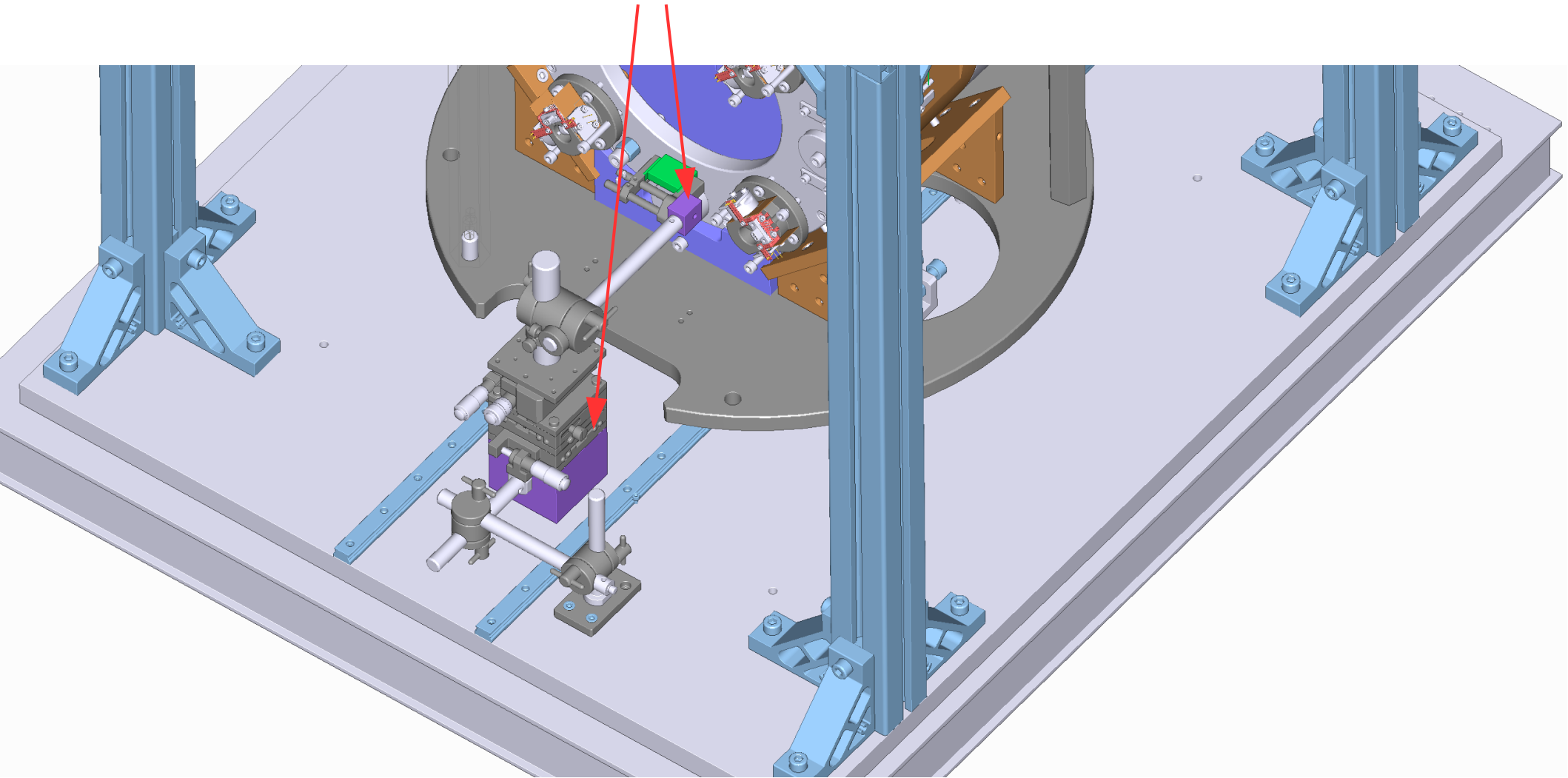

Everything else are off-the-shelf opto-mechanical parts

Installation Procedure 1

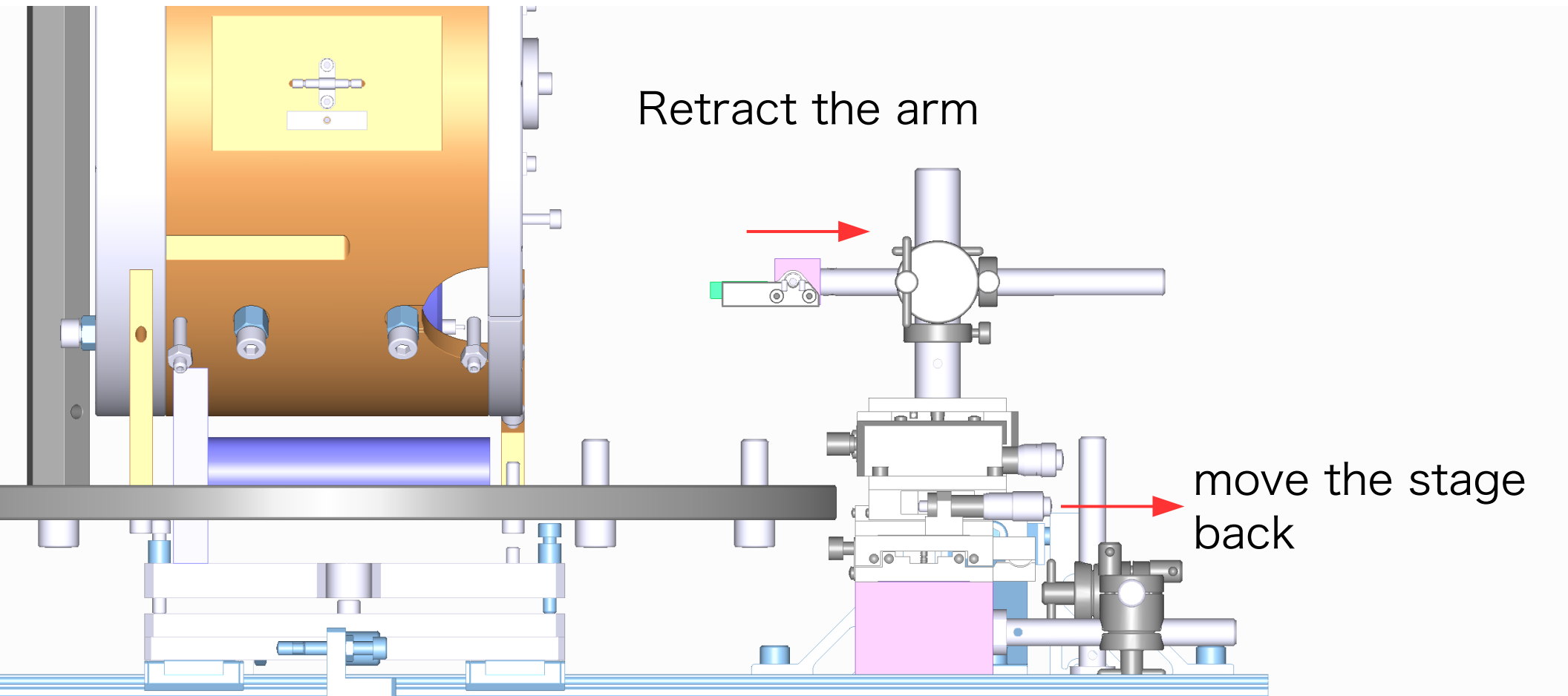

Installation Procedure 2

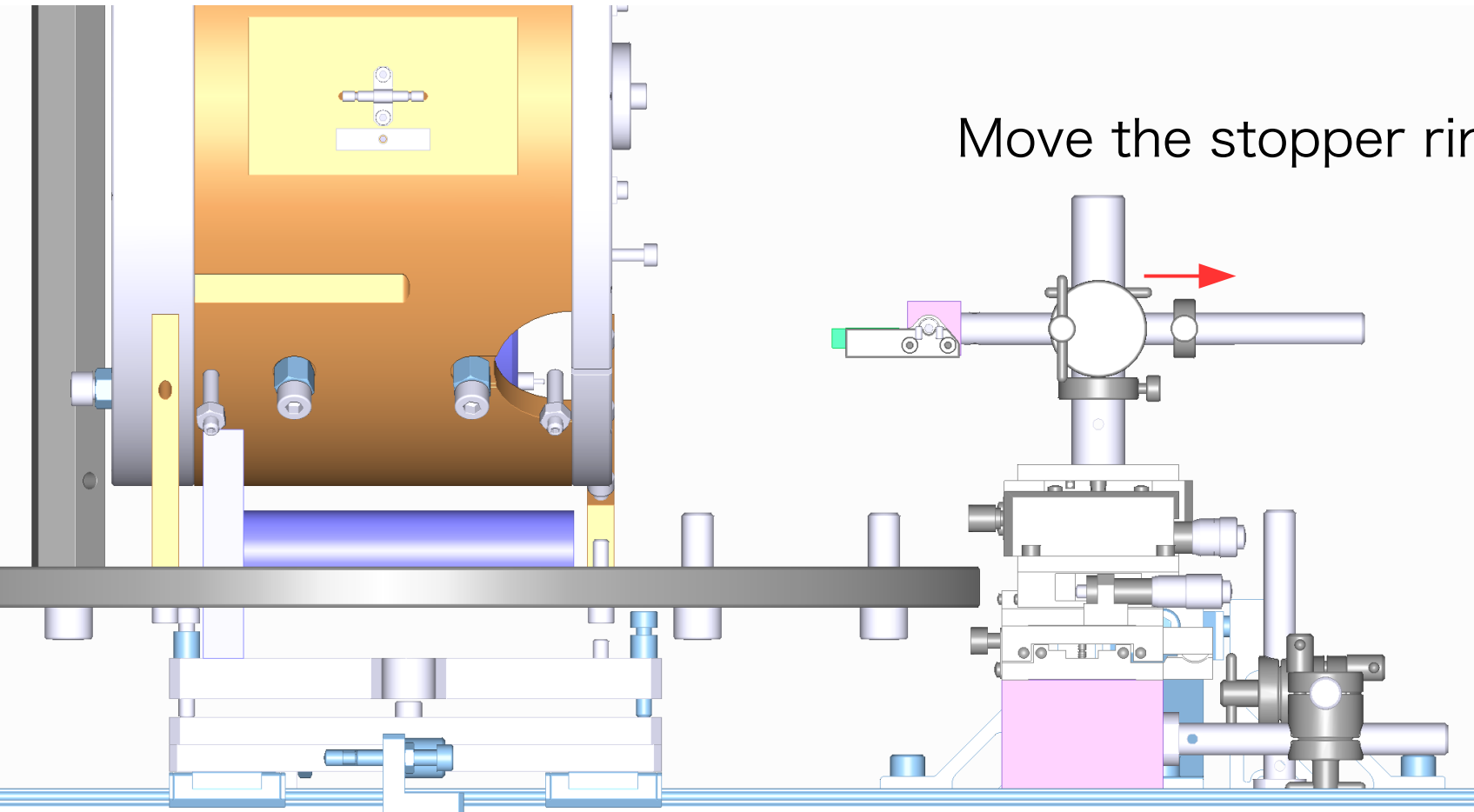

Move the stopper ring

Installation Procedure 3

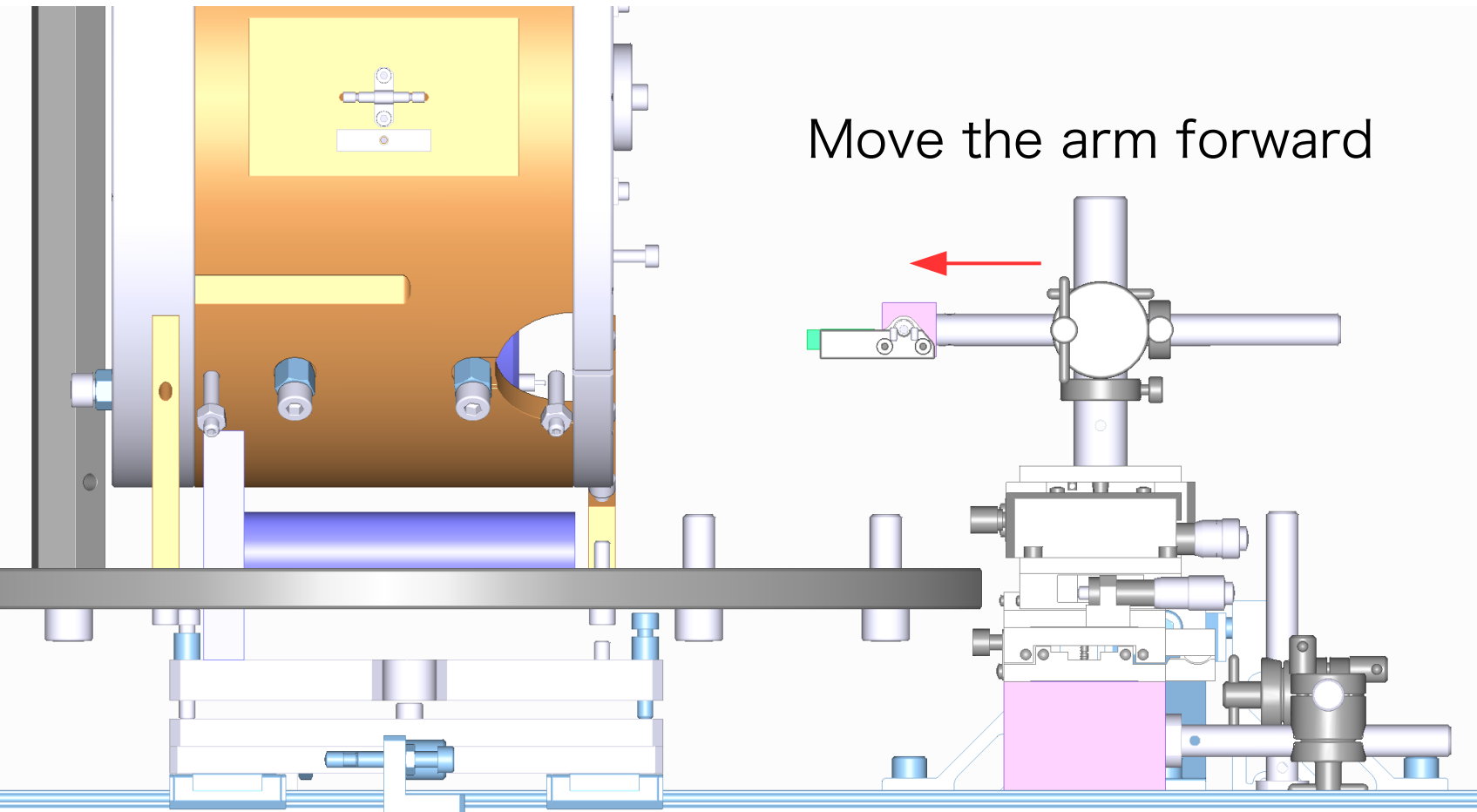

Installation Procedure 4

Repeat the step 2 and 3 many times until the photo sensor head gets roughly 1 cm from the recoil mass

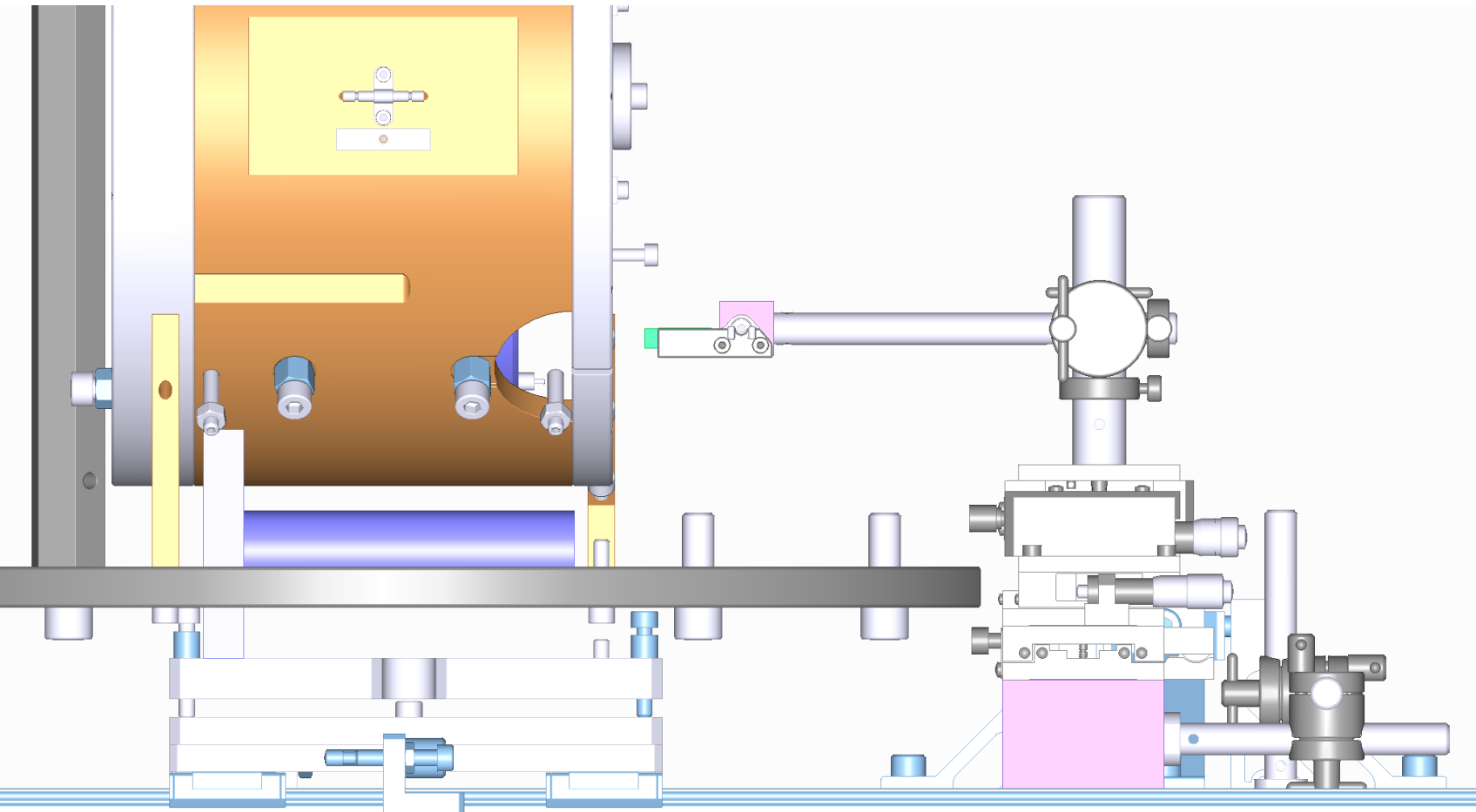

Installation Procedure 5

Use the micro-meter to put the sensor head very close to the recoil mass surface

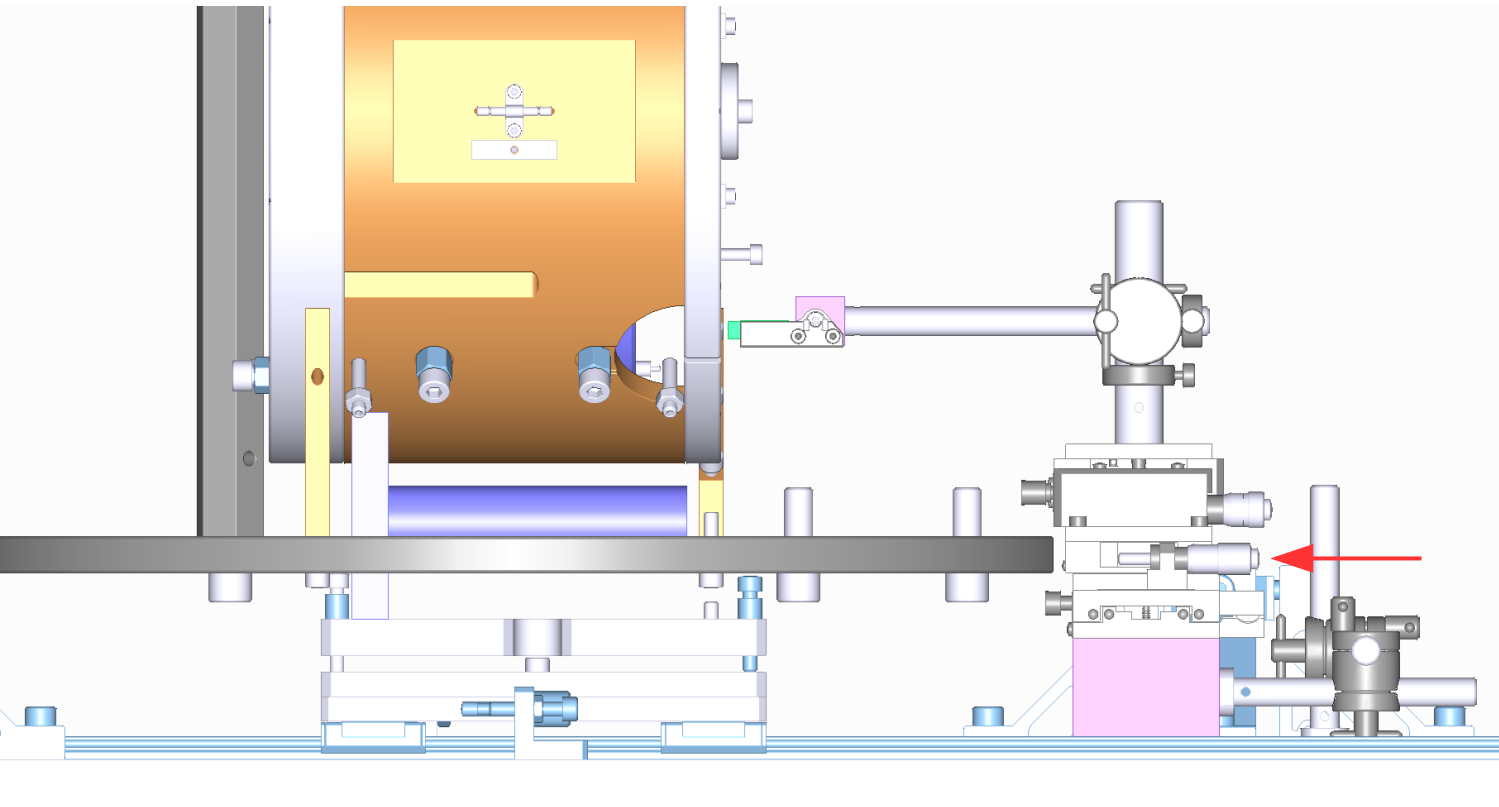

Two Photo-Sensor Configuration

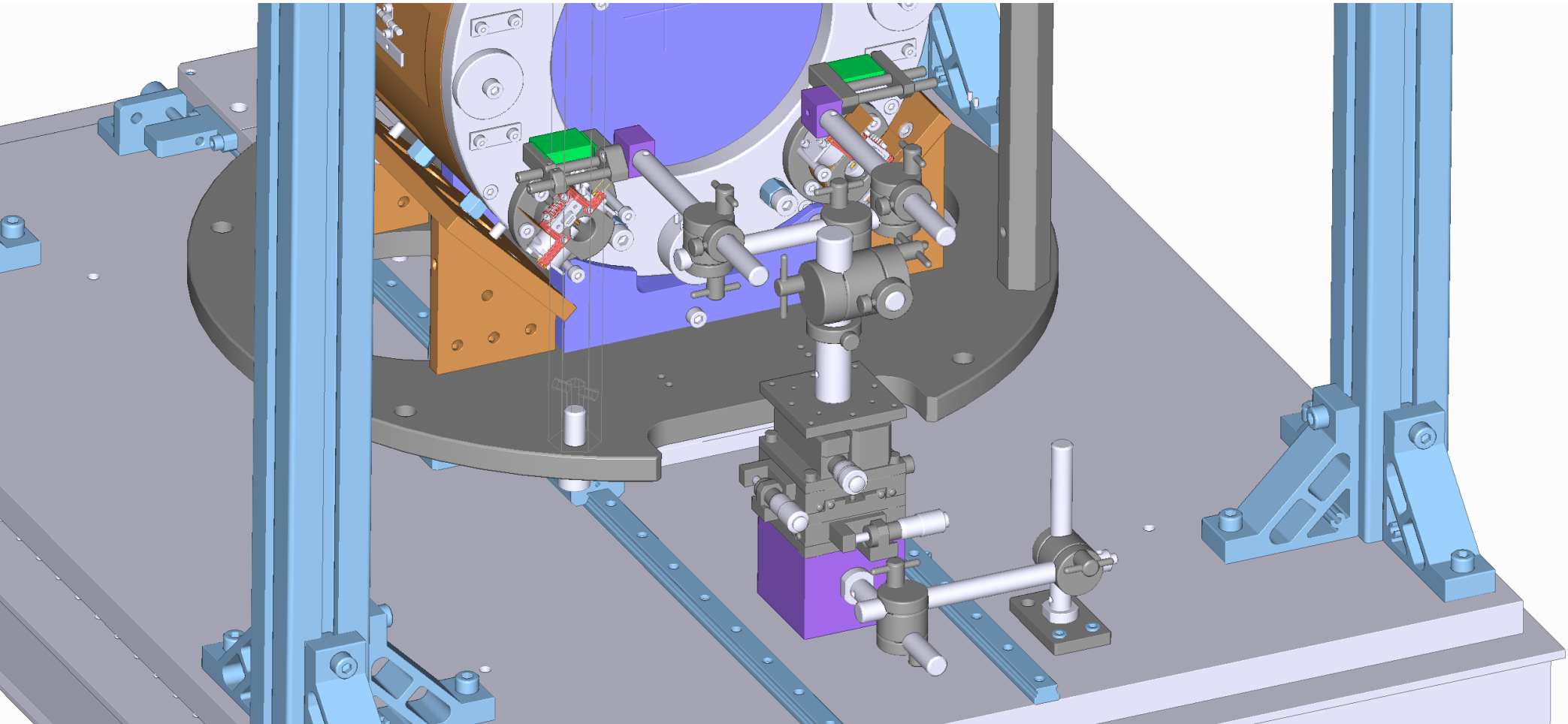

Two Photo-Sensor Configuration

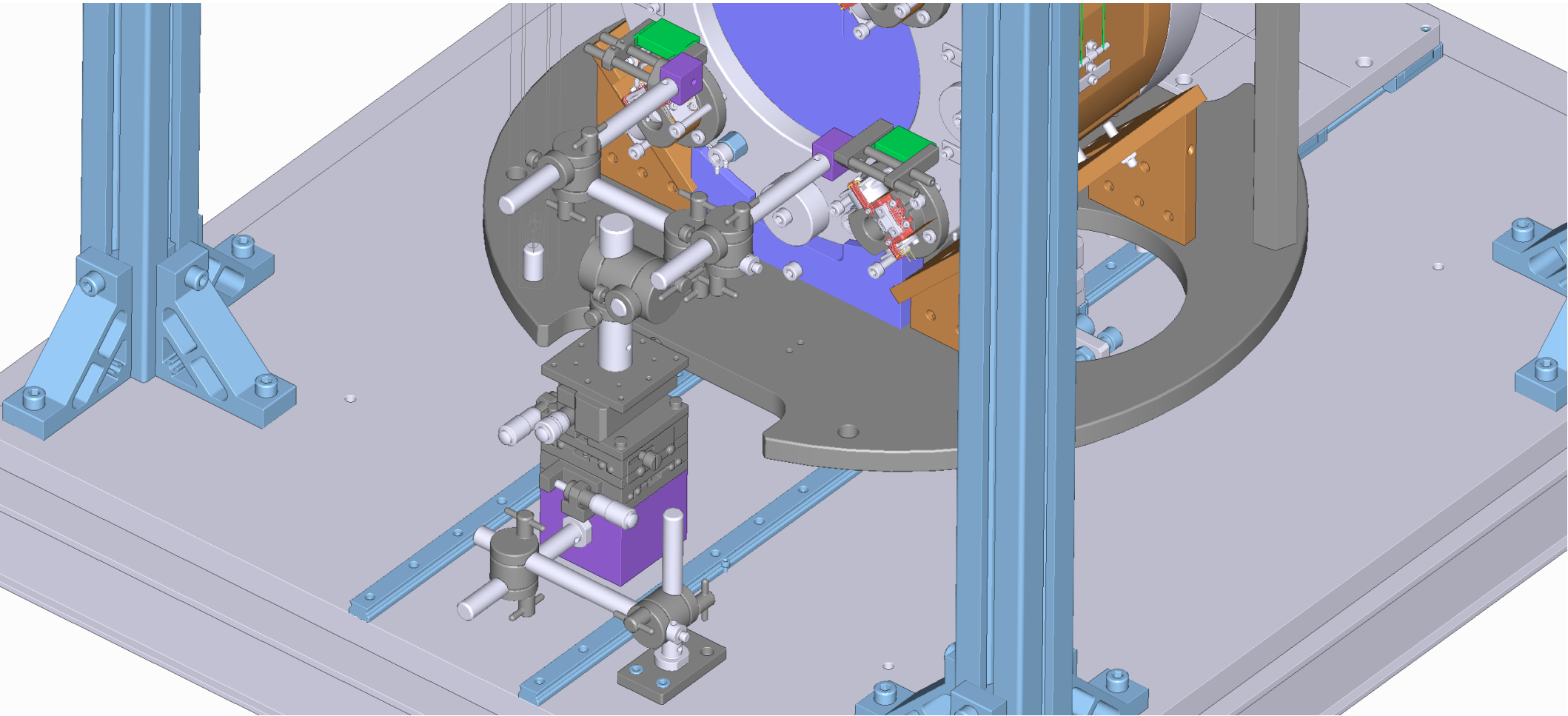

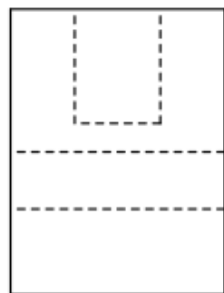
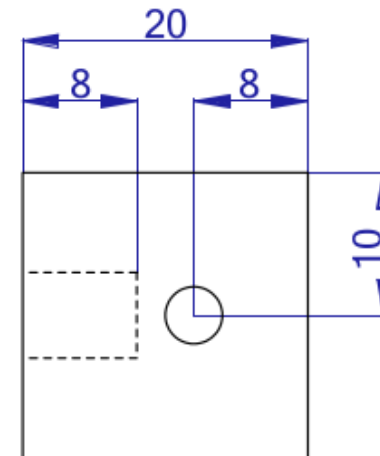
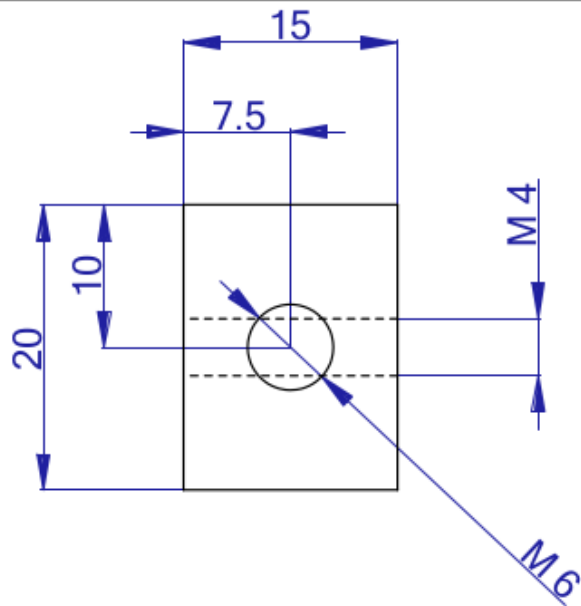

Drawing #	JGW-D1605845 part 1		Description	
Material	Aluminum (AI5052)	Tolerance	JISB0405-1991 m	
Quantity	2	Assembly No.		
Author	Yoichi Aso	Date	11/15/16	
Scale	5:1		Name Photo Sensor Mount	

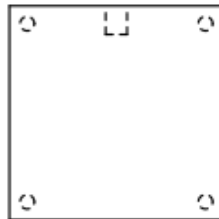
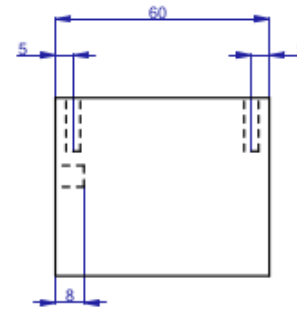
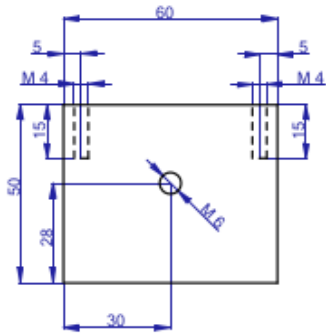

Drawing #	JGW-D1605845 part 2		Description	
Material	Aluminum (Al5052)	Tolerance	JIS B0405-1991 m	
Quantity	1	Assembly No.		
Author	Yoichi Aso	Date	11/16/16	
Scale	3:1		Name Stage base	

Off the shelf components

XYZ stage

駿河精機 B76-60C

Photo sensor clamp

Thorlabs CH1A

Other components from SIGMA Koki

PO-20-100

PO-12-100

CCHN-12-12 x 2

CCHN-20-12

RO-12-150 x 2

TR-12

TR-20

SP-109-1

Circuit Design

Original Photo Sensor Driving Topology

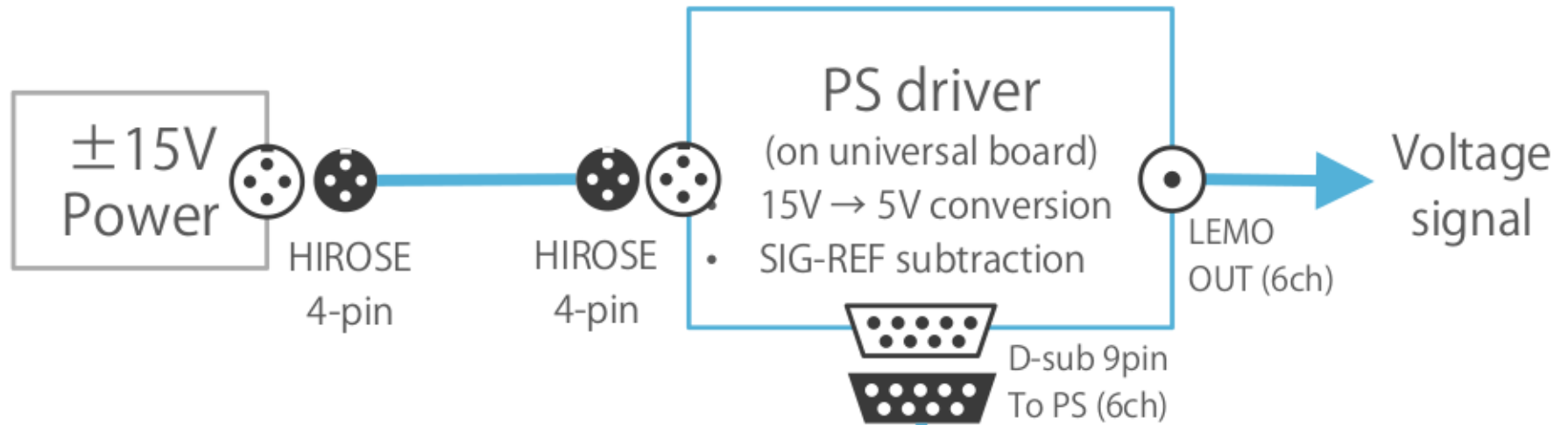
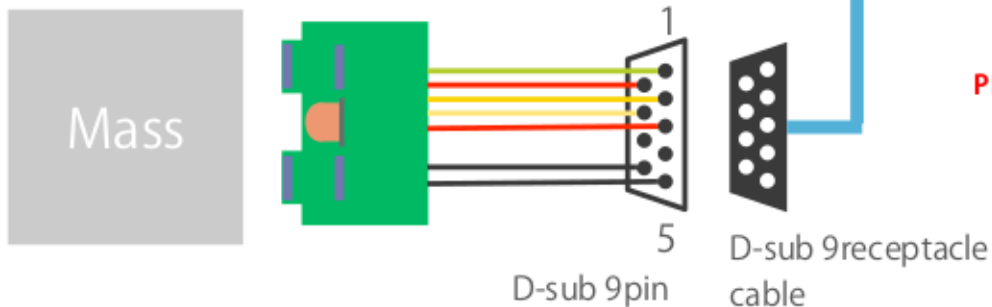
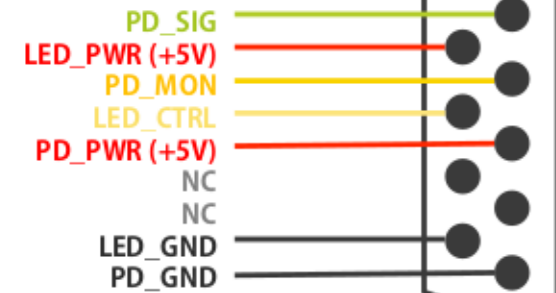

Photo-reflective sensor

- LED
- 2 x PD (SIG) + 2x PD (REF)
- Trans-impedance opamp



*PS pin assignment



We need to make an interface box for KAGRA

