

部品表						
項目	部品番号	部品名	材料	数量	表面处理	履歴番号
1	JGW-D1605462-1	Bottom Disk	SUS304	1		
2	JGW-D1605462 /2	Assembly Hat	Polycarbonate (clear)	1		
3	JGW-D1605462 /3	Welding Assembly	SUS304	1		
4	JGW-D1605462-4	Thread Rod	SUS304	1		
5	JGW-D1605462-5	Spacer	A6061	1		
6	JIS B 1169	Eye-nut M36	SUS304	2		
7	JIS B 1169	Eye-nut M20	SUS304	3		
8	JIS B 1169	Eye-nut M18	SUS304	3		
9	JIS B 1169	Eye-nut M8	SUS304	6		
10	JIS B 1176	Hexagon socket head cap screw M18x80	SUS304	9		
11	JIS B 1176	Hexagon socket head cap screw M20x80	SUS304	3		
12	JIS B 1176	Hexagon socket head cap screw M8x65	SUS304	6		
13	JIS B 1181	Hexagon nut M18	SUS304	6		

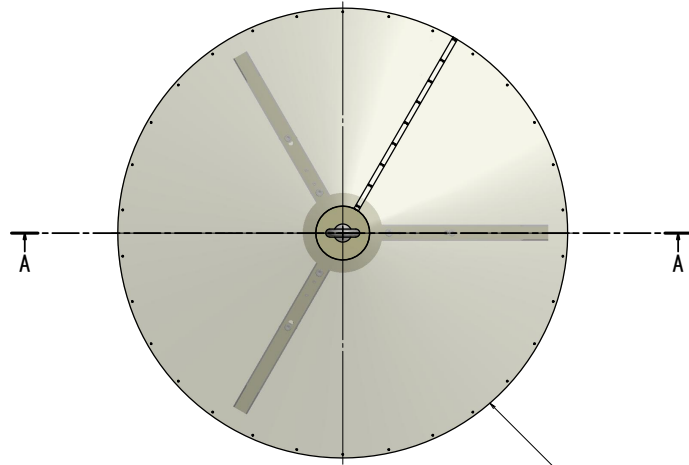

2

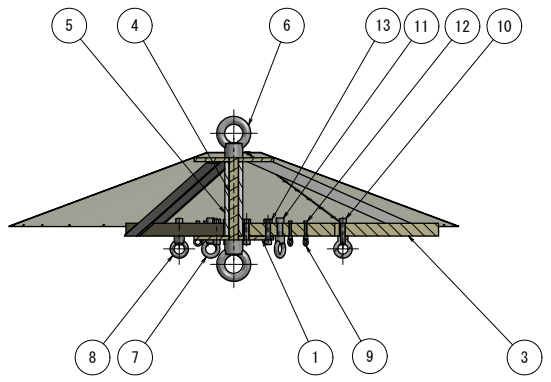

A-A

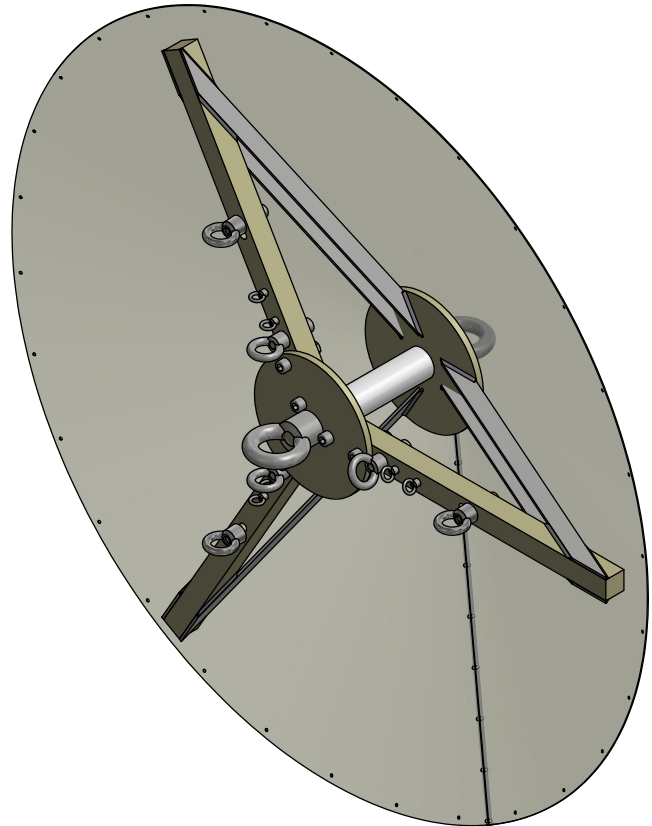

Unless otherwise specified:
 All dimensions are in millimeters (mm).
 Tolerances: JIS B 0419-mK
 Machining finish: Ra25
 Edge breaks: 0.2x45°

Name		KAGRA Type-A VIS	
Drawn		Assembly_HoistTool.iam	
Title		Hoist Tool	
Drawing No.		JGW-D1605462	
Sheet		1	
Designed		Ishizaki	
Drawn		Ishizaki	
Date		2016/10/12	
Checked		Sato	
Approved		Takahashi	
Projection		THIRD ANGLE PROJECTION	
Scale		1 : 10	
Material		A1	
Organization		National Astronomical Observatory of Japan	
Page		1 / 1	

部品表						
項目	部品番号	部品名	材料	数量	表面処理	変更履歴
1	JGW-D160652-7	Hat Disk	Polycarbonate clear	1		
2	JGW-D160652-8	Hat Joint	Polycarbonate clear	1		
3	JIS B 1213 - 4 x 10	丸リベット	A6061	18		

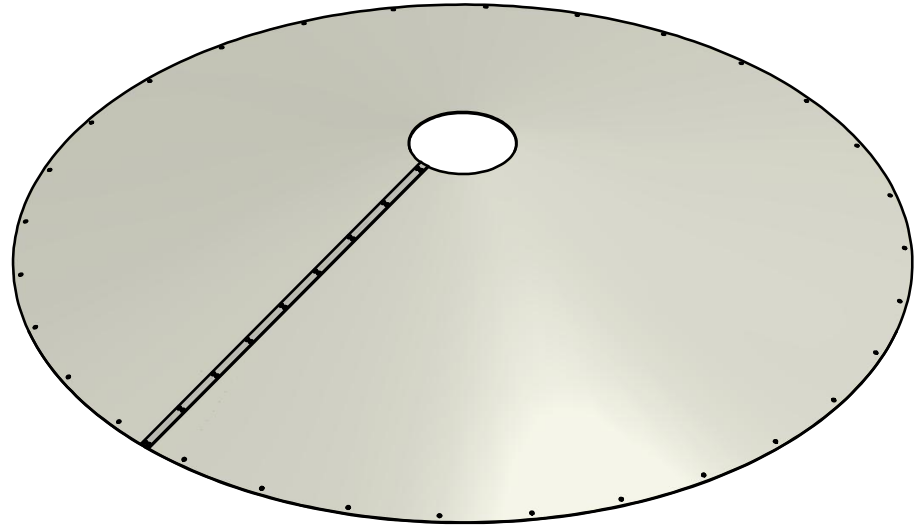
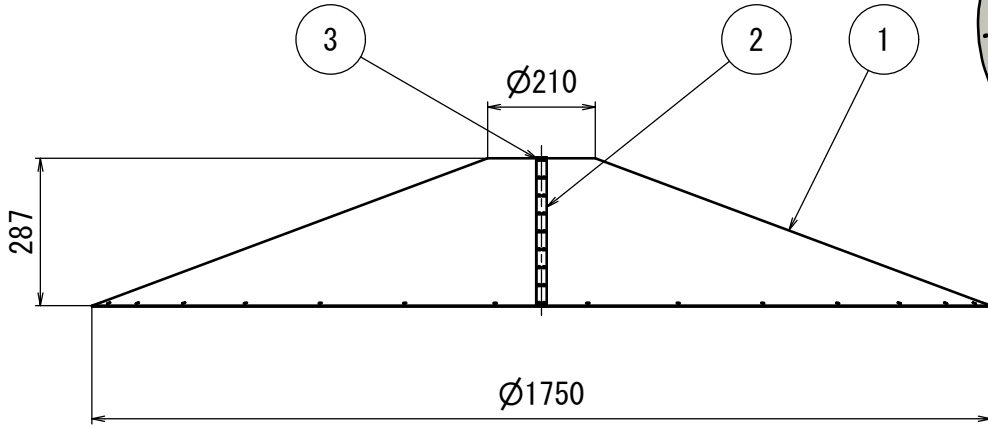

Unless otherwise specified:
 All dimensions are in millimeters (mm).
 Tolerances: JIS B 0419-mK
 Machining finish: Ra25
 Edge breaks: 0.2x45°

Project
 KAGRA Type-A VIS

Material Polycarbonate (clear)		Source Assembly_HoistTool_Hat.iam	
FINISH		Title Assembly Hat	
	NAME	DATE	Drawing No. JGW-D1605462 /2
Designed	ishizaki		Rev. 1
Drawn	ishizaki	2016/10/12	Scale 1 : 10
Checked	Sato		THIRD ANGLE PROJECTION
Approved	Takahashi		1 / 1

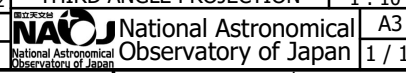

部品表						
項目	部品番号	部品名	材料	数量	表面処理	履歴番号
4	JGW-D1605462-2	Main Rod	SUS304	3		
5	JGW-D1605462-3	Tie Plate	SUS304	6		
6	JGW-D1605462-6	Top Disk	SUS304	1		

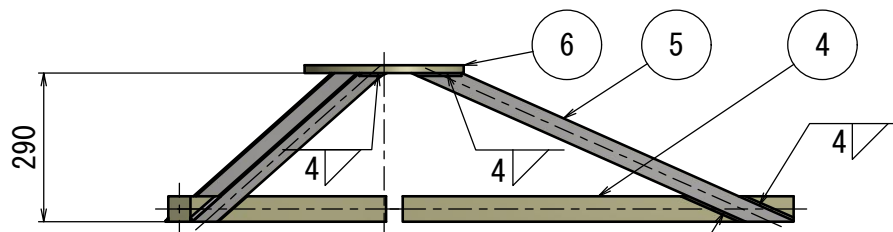

隅肉溶接は、サイズ4、(円周上の)6か所

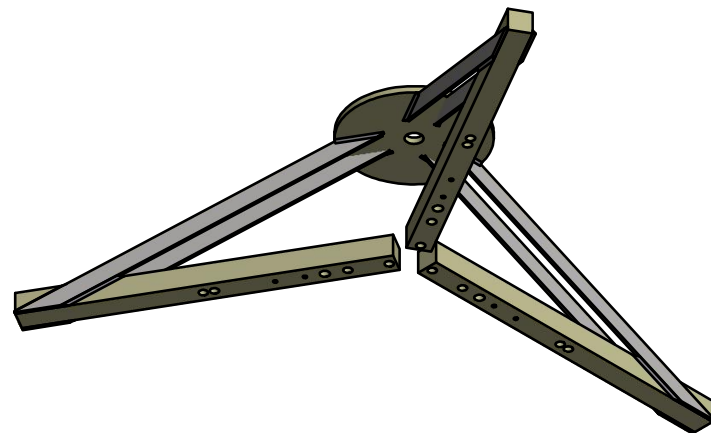
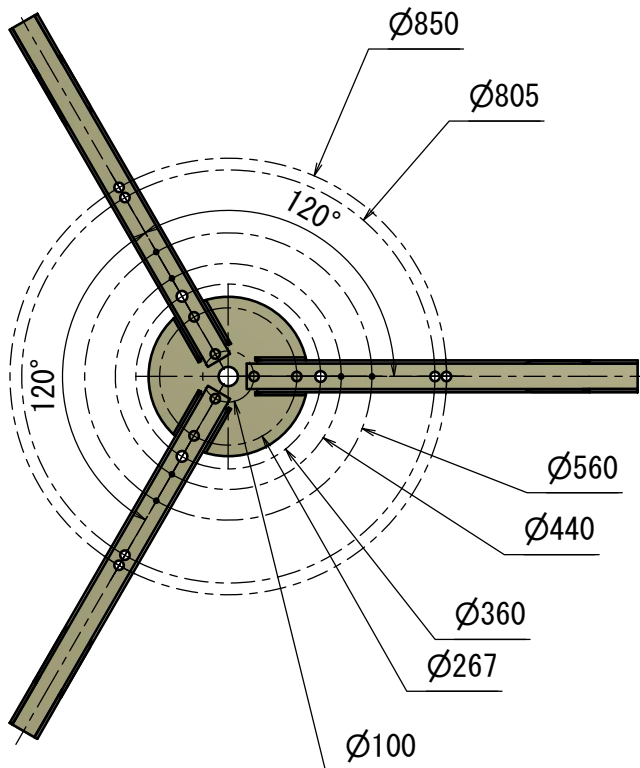

Unless otherwise specified:
 All dimensions are in millimeters (mm).
 Tolerances: JIS B 0419-mK
 Machining finish: Ra25
 Edge breaks: 0.2x45°

Project
 KAGRA Type-A VIS

Material	SUS304		Source	Assembly_WeldingParts.iam	
FINISH	電解研磨		Title	Welding Assembly	
	NAME	DATE	Drawing No.	JGW-D1605462 /3	Rev. 1
Designed	ishizaki		THIRD ANGLE PROJECTION		
Drawn	ishizaki	2016/10/12	Scale	1 : 10	
Checked	Sato		 National Astronomical Observatory of Japan		
Approved	Takahashi		1 / 1		

部品表 (1 set分)						
項目	部品番号	部品名	数量	材料	表面処理	履歴番号
1	JGW-D1605462-9	Anchor Plate for SF	1	SS400		
2	JIS B 1176	Hexagon socket head cap screw M6x20	1	SUS304		
3	JIS B 1176	Hexagon socket head cap screw M5x16	4	SUS304		
4	JIS B 1169	Eye-nut M6	1	SUS304		

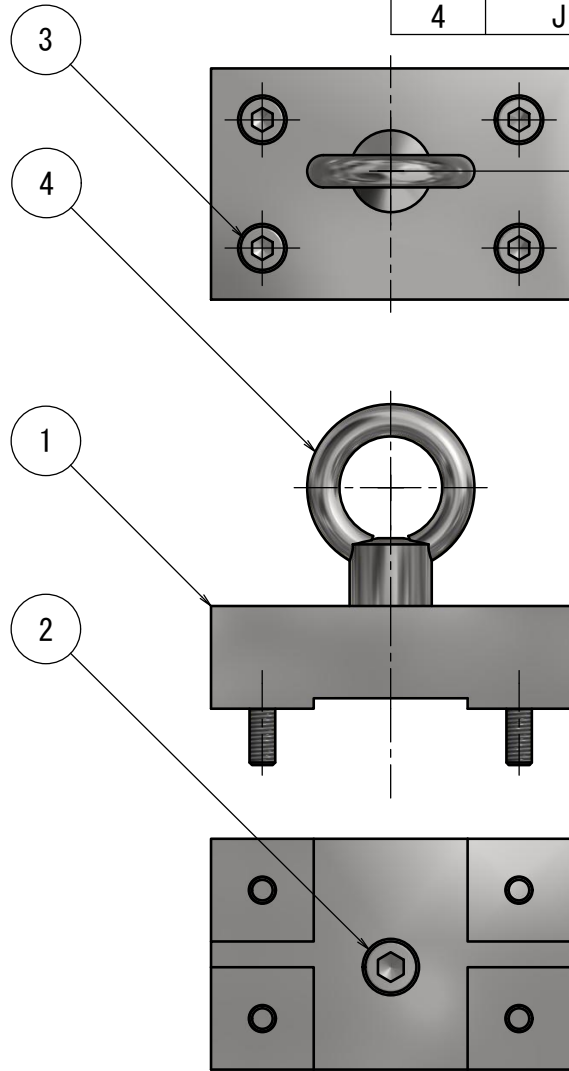

Standard Filterの中心から220

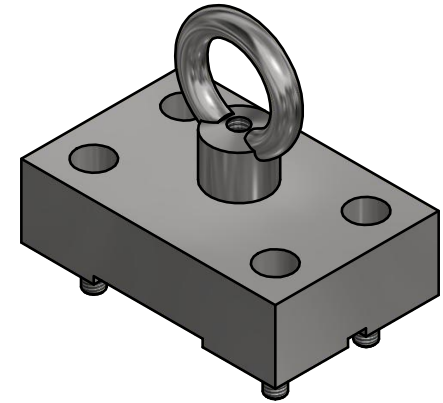

3 setで1組

Unless otherwise specified:
 All dimensions are in millimeters (mm).
 Tolerances: JIS B 0419-mK
 Machining finish: Ra25
 Edge breaks: 0.2x45°

Project
 KAGRA Type-A VIS

Source
 Assembly_SF_hangingJig.iam

Title
 SF hanging jig

Material			Source	
FINISH			Title	
			SF hanging jig	
			Drawing No.	
			JGW-D1605462 /4	
			Rev.	
			1	
Designed	ishizaki	DATE	THIRD ANGLE PROJECTION	
Drawn	ishizaki	2016/10/13	Scale	
Checked	Sato		1 : 1	
Approved	Takahashi		A3	
			1 / 1	

National Astronomical Observatory of Japan