

部品表						
項目	部品番号	部品名	材料	数量	表面処理	履歴番号
1	JGW-D1605460-1	Frame Lock	SUS304	1	電解研磨	
2	JGW-D1605460-2	Top Ring Security Structure	SUS304	1	電解研磨	
3	JGW-D1605460-3	End Plate 1	SUS304	4	電解研磨	
4	JGW-D1605460-4	End Plate 2	SUS304	1	電解研磨	
5-1	JGW-D1605460-5-1	First Rod 1	SUS304	6	バフ研磨	1
5-2	JGW-D1605460-5-2	First Rod 2	SUS304	6	バフ研磨	1
6	JGW-D1605460-6	Second Rod	SUS304	6	バフ研磨	1
7	JGW-D1605460-7	Third Rod	SUS304	6	バフ研磨	1
8	JGW-D1605460-8	Fourth Rod	SUS304	3	バフ研磨	
9	JGW-D1605460-9	Heat Shield 1	A6061	1	化学研磨	2
10	JGW-D1605460-10	Heat Shield 2	A6061	3	化学研磨	2
11	JGW-D1605460-11	Frame Lock Pin	SUS304	10		
12	JGW-D1605460-12	Stopper Filter	A6061	15		

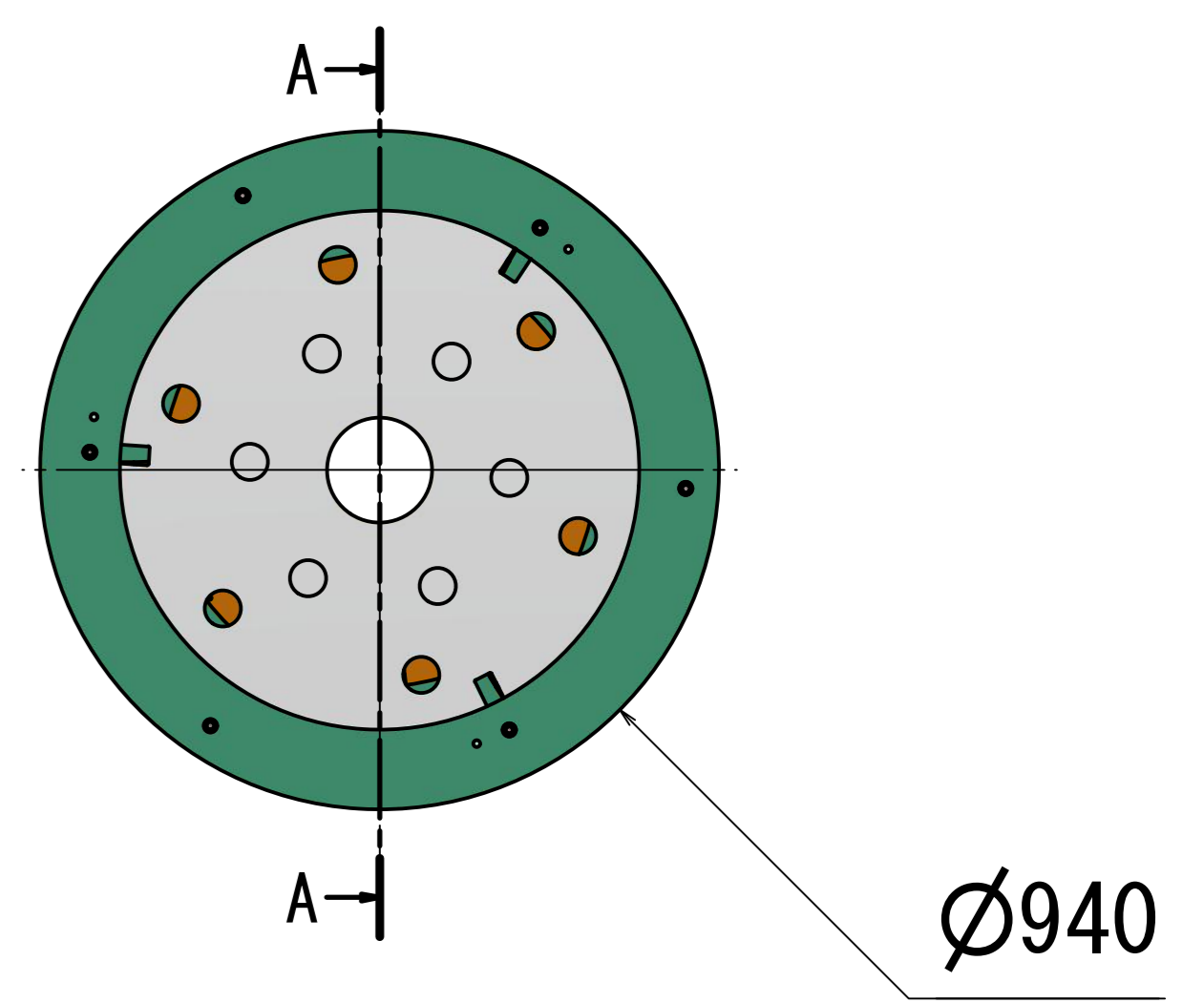

変更履歴				
ゾーン	履歴	説明	日付	認可
3-14 D	1	長さ改訂	2016/09/05	
3-14 D	2	穴加工追加	2016/10/05	

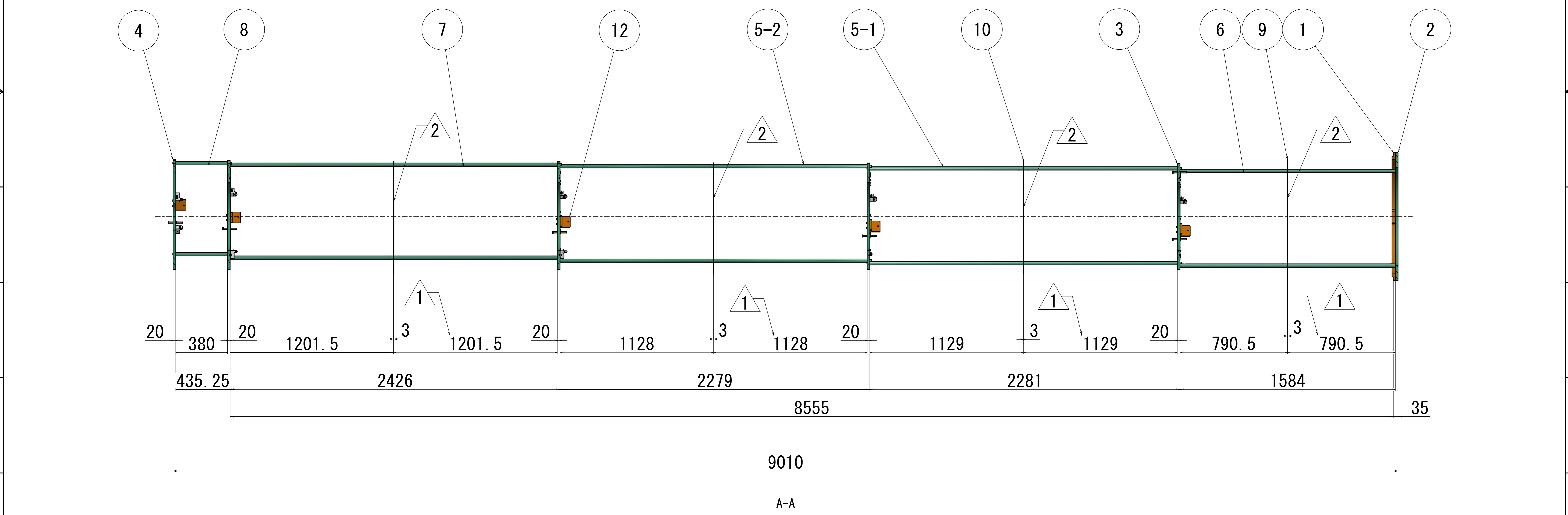

Unless otherwise specified:  
 All dimensions are in millimeters (mm).  
 Tolerances: JIS B 0419-mK  
 Machining finish: Ra25  
 Edge breaks: 0.2x45°

Name		KAGRA Type-A VIS	
Title		Assembly_new_EarthquakeStop_wholeiam	
Part No.		Earth Quake Stop of Type-A	
Design	NAME	DATE	REV
Designed	Ishizaki Sato		JGW-D1605460 1
Drawn	Ishizaki Sato	2016/08/10	THIRD ANGLE PROJECTION 1/10
Checked	Sato		NAC National Astronomical Observatory of Japan A0
Approved	Takahashi		1/1

・ PROMEC No. \_0004-03