

Arm Length Stabilization Conceptual Configuration

Yuta Michimura

Department of Physics, University of Tokyo

Candidate (aLIGO-like)

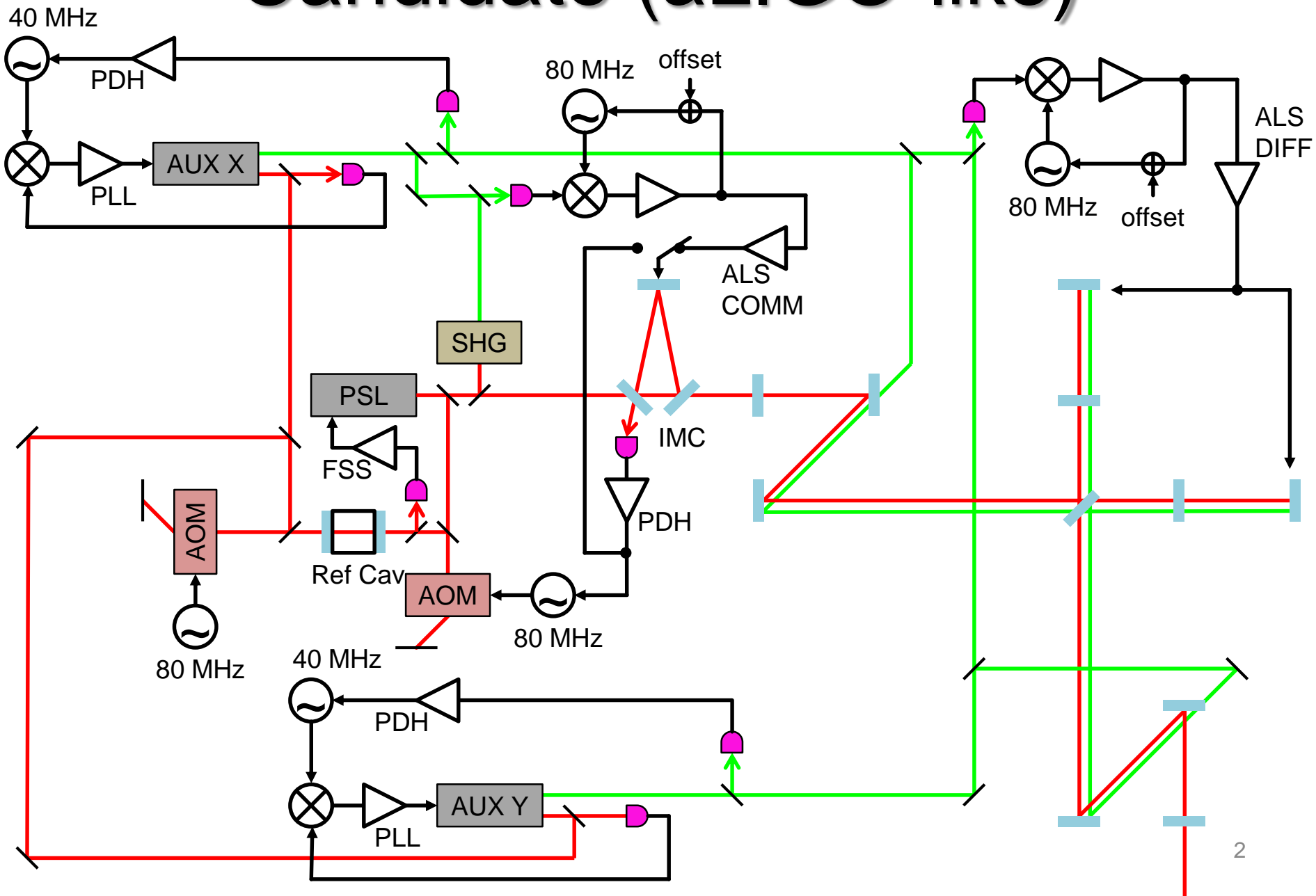

Considerations

- Where to put PLL setup for PSL vs AUX X/Y
- Where to put green beat setup for ALS COMM
- Where to put green beat setup for ALS DIFF

- Plan 1: All at PSL clean booth
 - need two fibers to send AUX green to POS/POP table
 - enough space for optics at PSL table? [Nakano]
 - enough space for electronics at IOO racks? [Michimura]
 - > yes

- Plan 2: AUX X at POP, AUX Y at POS
 - need two fibers to send PSL green to POS/POP table
beat for PLL also with green?
 - need one fiber to send AUX X green to POS
 - enough space for electronics at ISC racks? [Michimura]
 - > yes

Setup for Table-Top Experiment?

- Conceptual drawing made by Kambara
- to be fixed [Kambara]

Schedule

- to be fixed [Matsushima]
- very rough schedule
 - 2016.7-10: ALS design
 - 2016.10-2017.9: Table-top experiment at Univ. Toyama
 - 2017.10-2018.3: Installation at Kamioka
 - 2018.8: ITM/ETM CRYp installation complete
 - 2018.9-: ALS experiment at Kamioka

Releated References

- aLIGO configuration
<https://alog.ligo-wa.caltech.edu/aLOG/index.php?callRep=11083>
<http://gwdoc.icrr.u-tokyo.ac.jp/cgi-bin/private/DocDB/ShowDocument?docid=1895>
- Study by Tasumi-san *et al.* in 2011-2012
<https://granite.phys.s.u-tokyo.ac.jp/svn/Private/trunk/LCGTbackup/GreenLock/>