

bKAGRA

Vibration Isolation Systems

2016/6/21@PAB
Y. Aso (NAOJ)

VIS Overview

KAGRA Vibration Isolation Systems

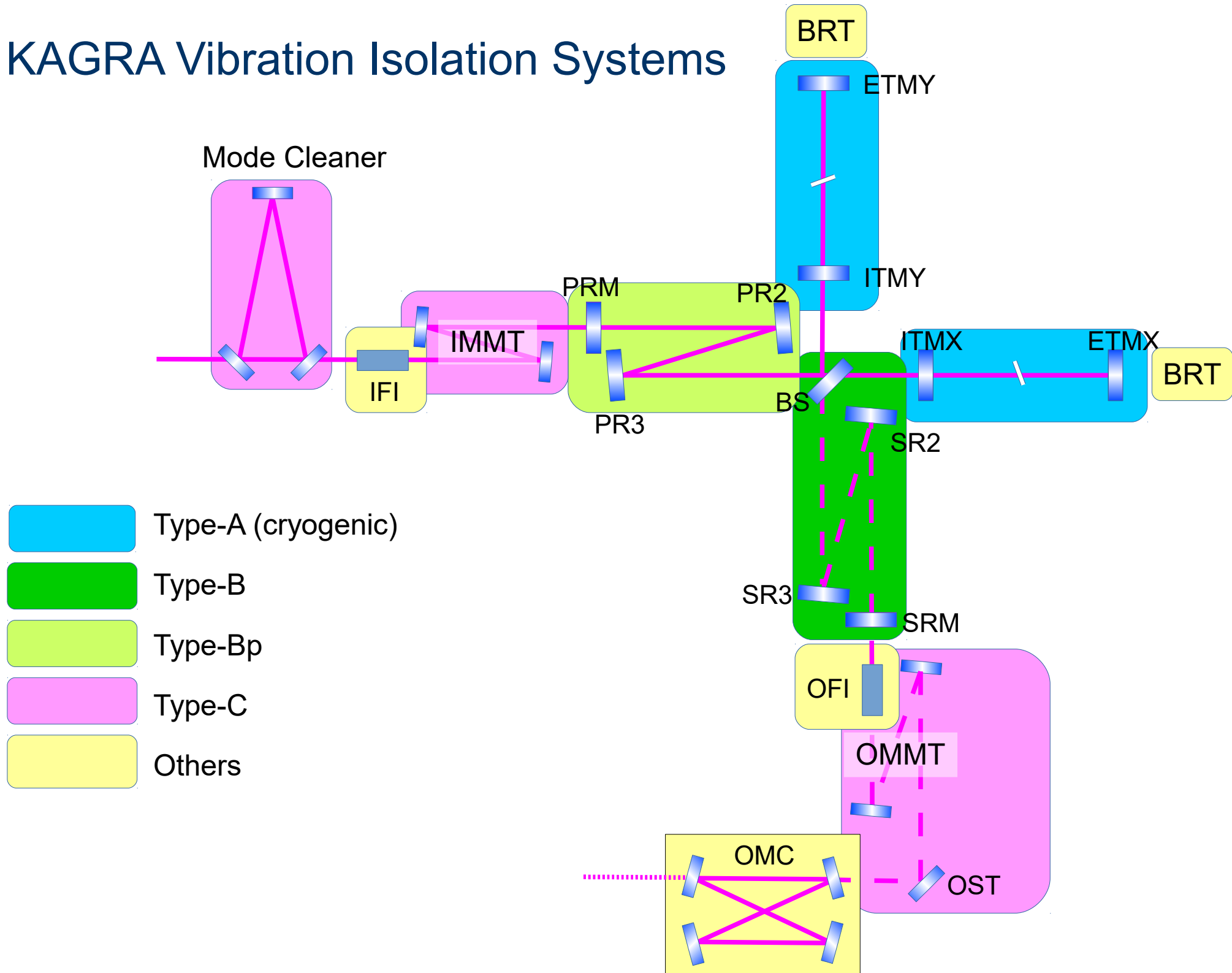

Suspensions need to be installed from **Now**

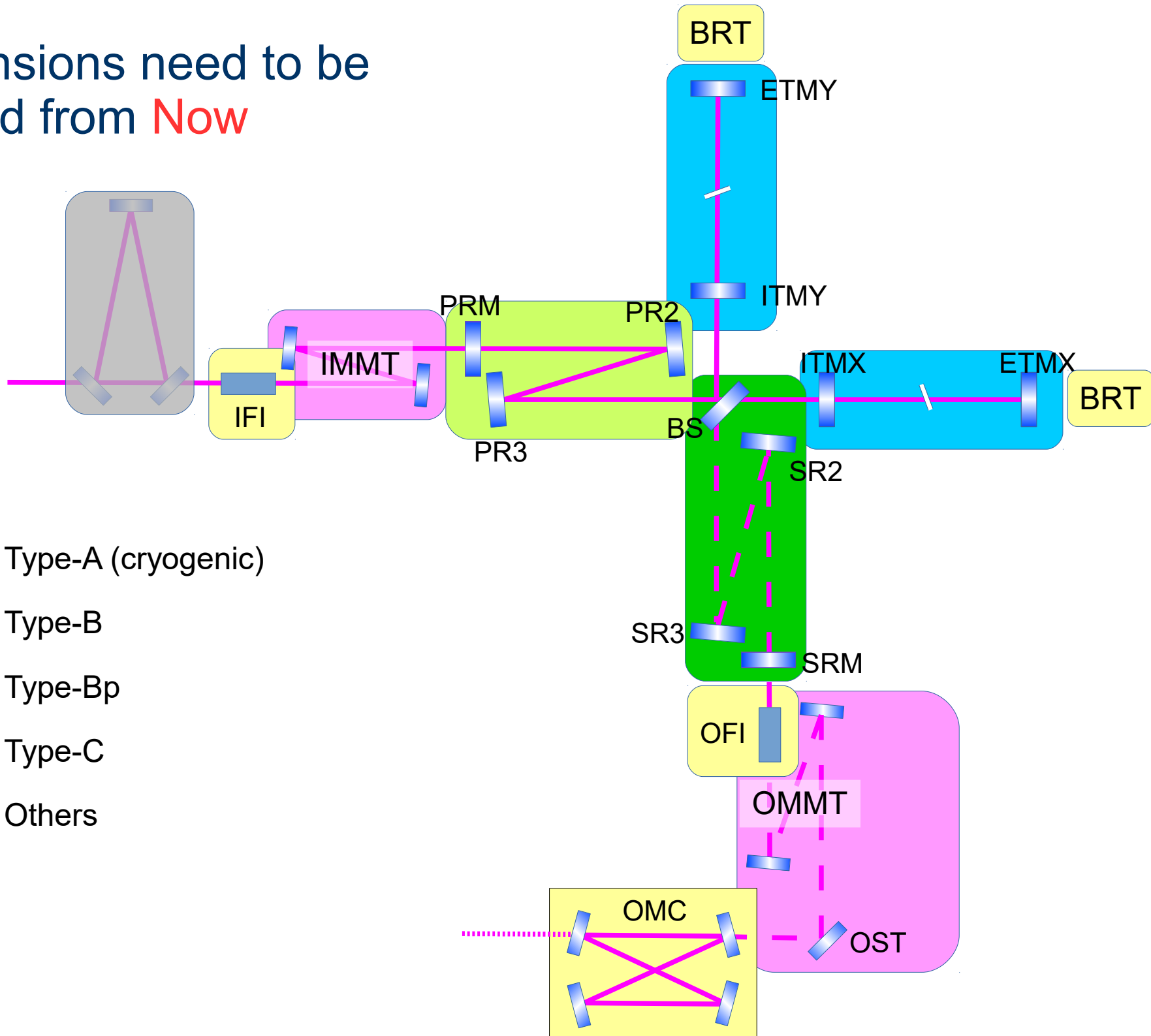

Three types of large suspensions

Type-Bp

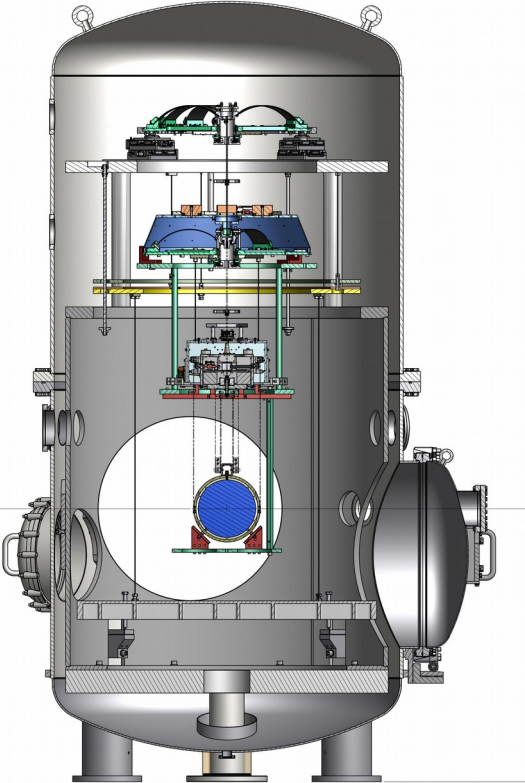

Type-B

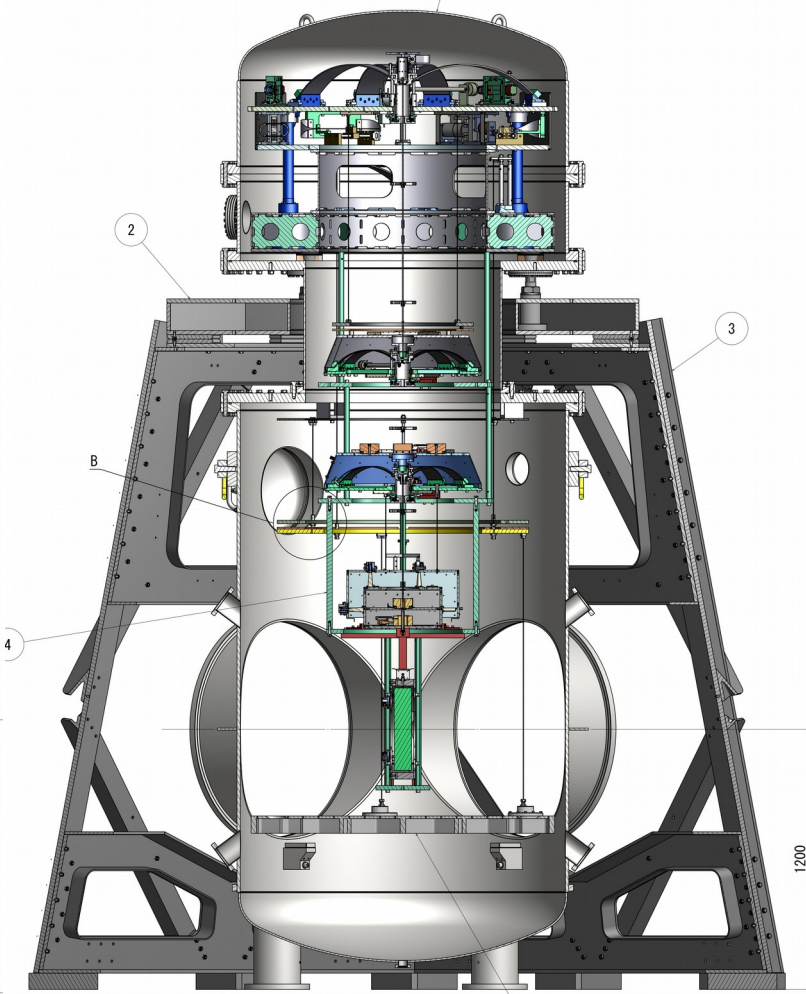

Type-A



Other vibration isolation systems

- MC (TAMA suspensions, installed)
- IMMT (TAMA suspensions)
- Output optics
 - OFI (modified TAMA suspension ?)
 - OMMT (newly built TAMA like suspension)
 - OST (newly built TAMA like suspension)
 - OMC (custom made one)
- BRT
 - Custom made one

Who is responsible for what ?

Large suspension systems + IMMT

(Type-A w/o cryo payload, Type-B, Type-Bp, Type-C)

→ VIS subsystem (NAOJ)

Cryogenic Payload

→ CRY (KEK)

Beam Reducing Telescope Suspensions

→ AOS (NAOJ)

Output Optics Suspensions

(OFI, OMMT, OST, OMC + IFI?)

→ IOO ?

What happened in iKAGRA ?

iKAGRA VIS: Original Plan

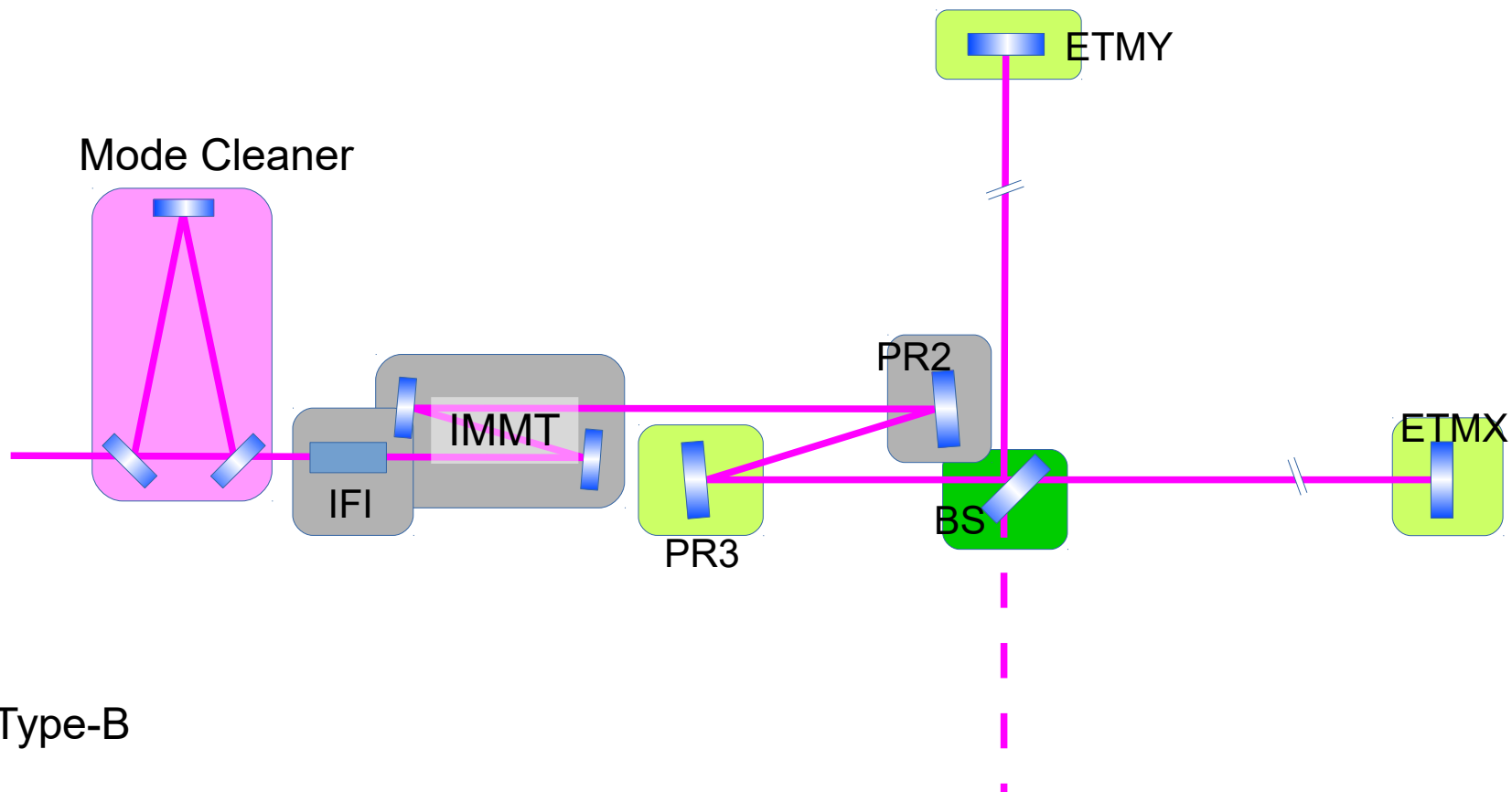

Type-B



Type-Bp'



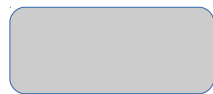

Type-C

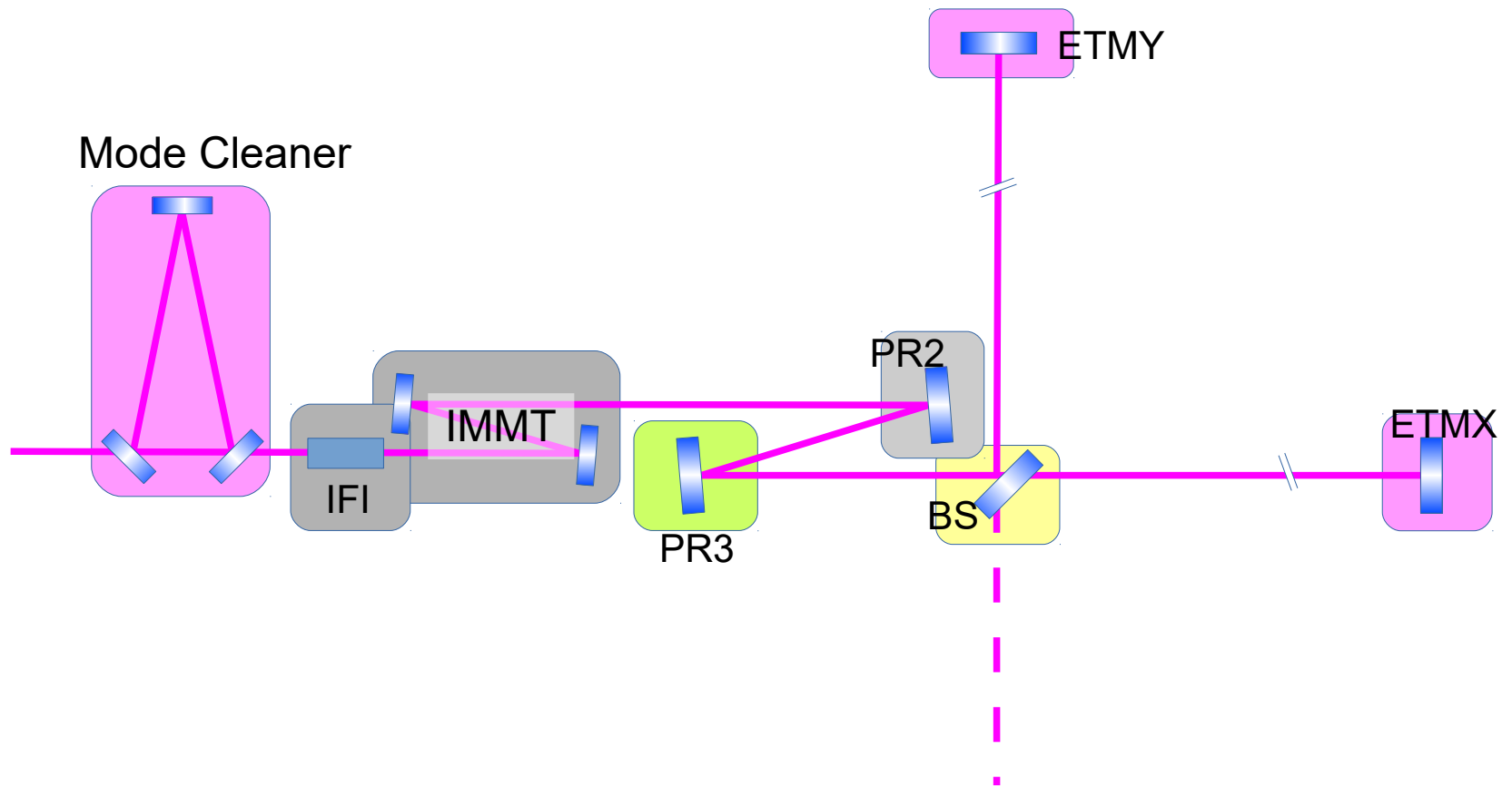

Fixed to the ground

iKAGRA VIS: What happened

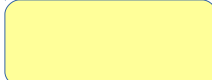
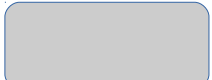

-  Type-Bp'
-  Type-C
-  CLIO Suspension
-  Fixed to the ground

VIS installation took much longer than expected

PR3 was the only large suspension installed

- Tunnel environment
- Insufficient preparation
 - Parts missing
 - Not-well-established installation procedure
 - Incorrect drawings
 - Tools missing
- Troubles
 - Cracks in the sapphire prisms
 - Broken OSEM flags
 - Wrong cables
 - Screw galling

Original estimate of installation work duration

1 month for PR3

Actually happened

3 months for test installation, 1.5 months for the actual installation.

PR2 wire breaker developed cracks

- Small size (2mm height)
- Rough surface finish
- No annealing (!)

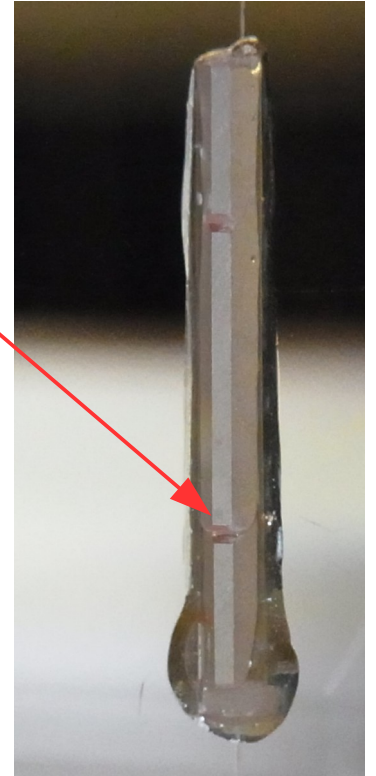

Operation of iKAGRA by the end of 2016 March
was a strict requirement

We needed to do something about it

Fixed PR2

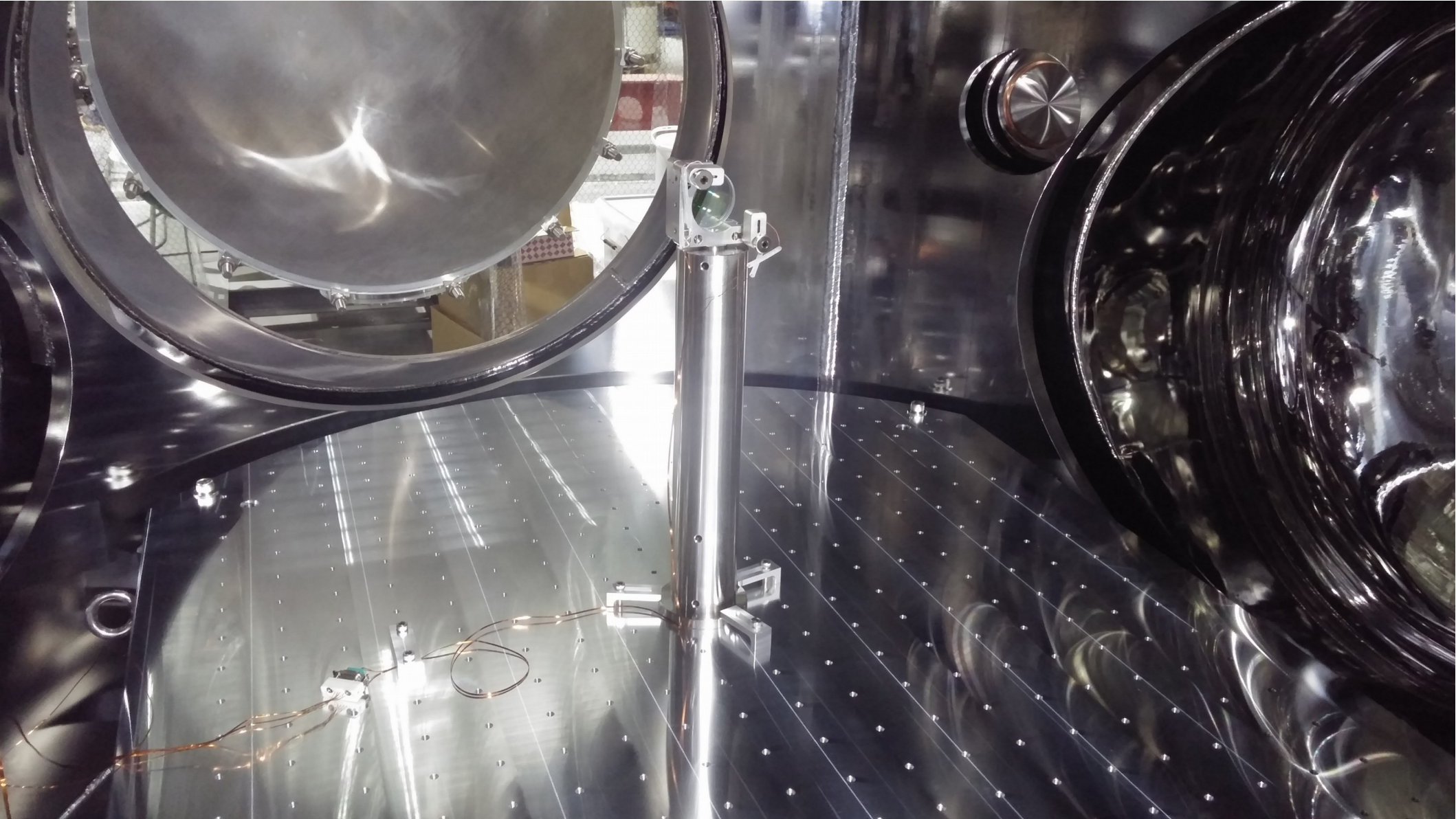

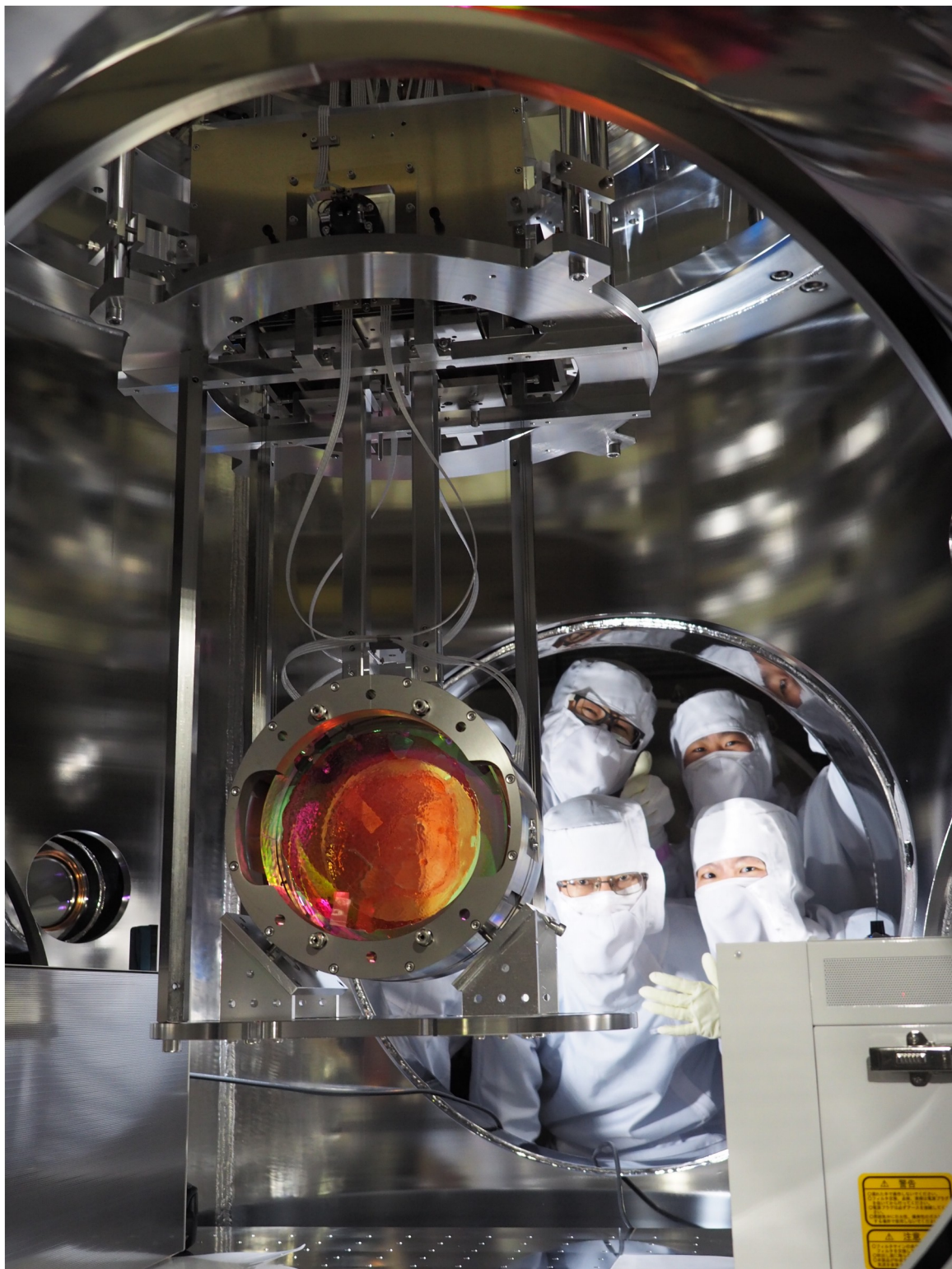

Plan for bKAGRA

Suspensions need to be installed from **Now**

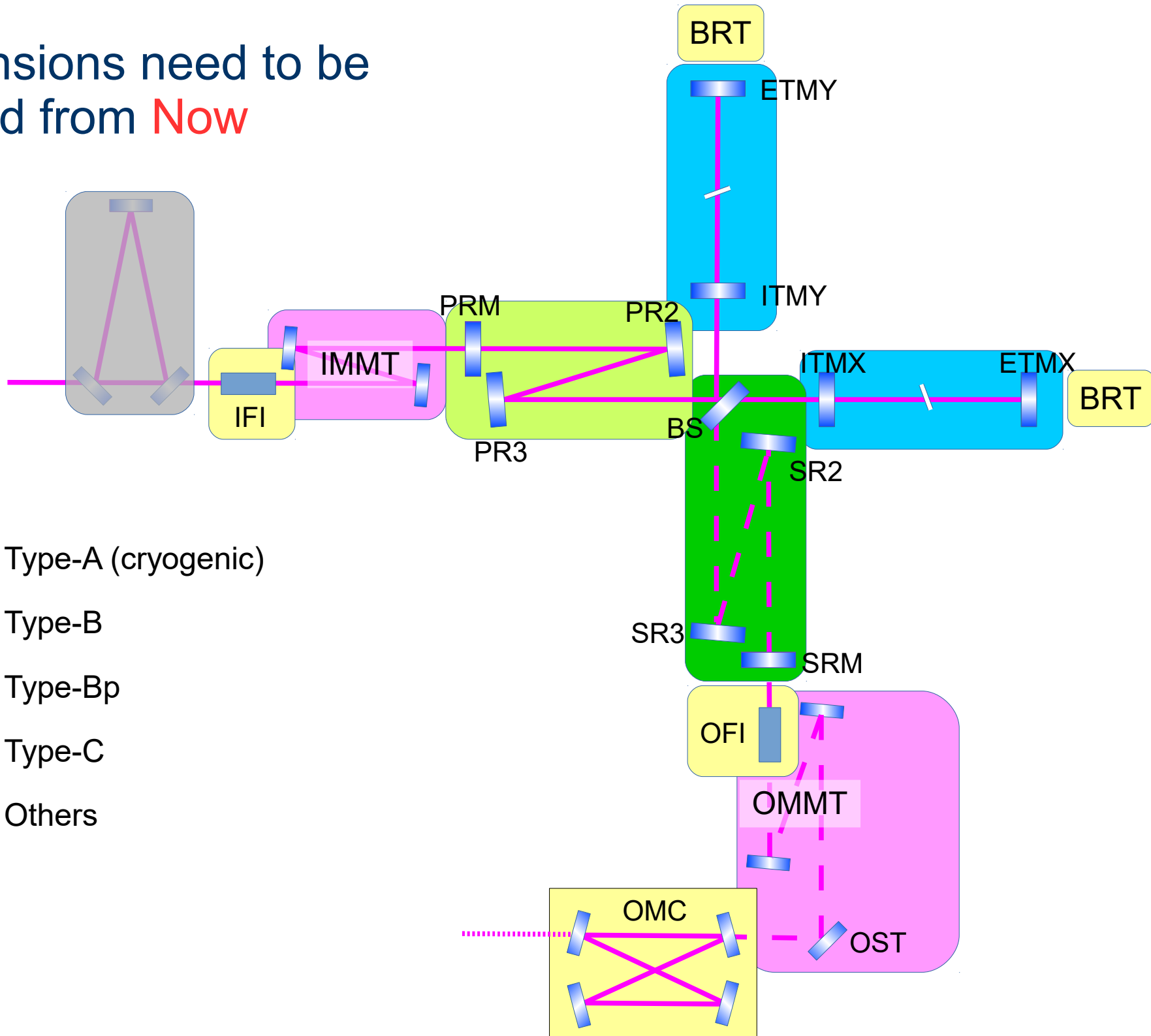

I will focus on the large suspensions

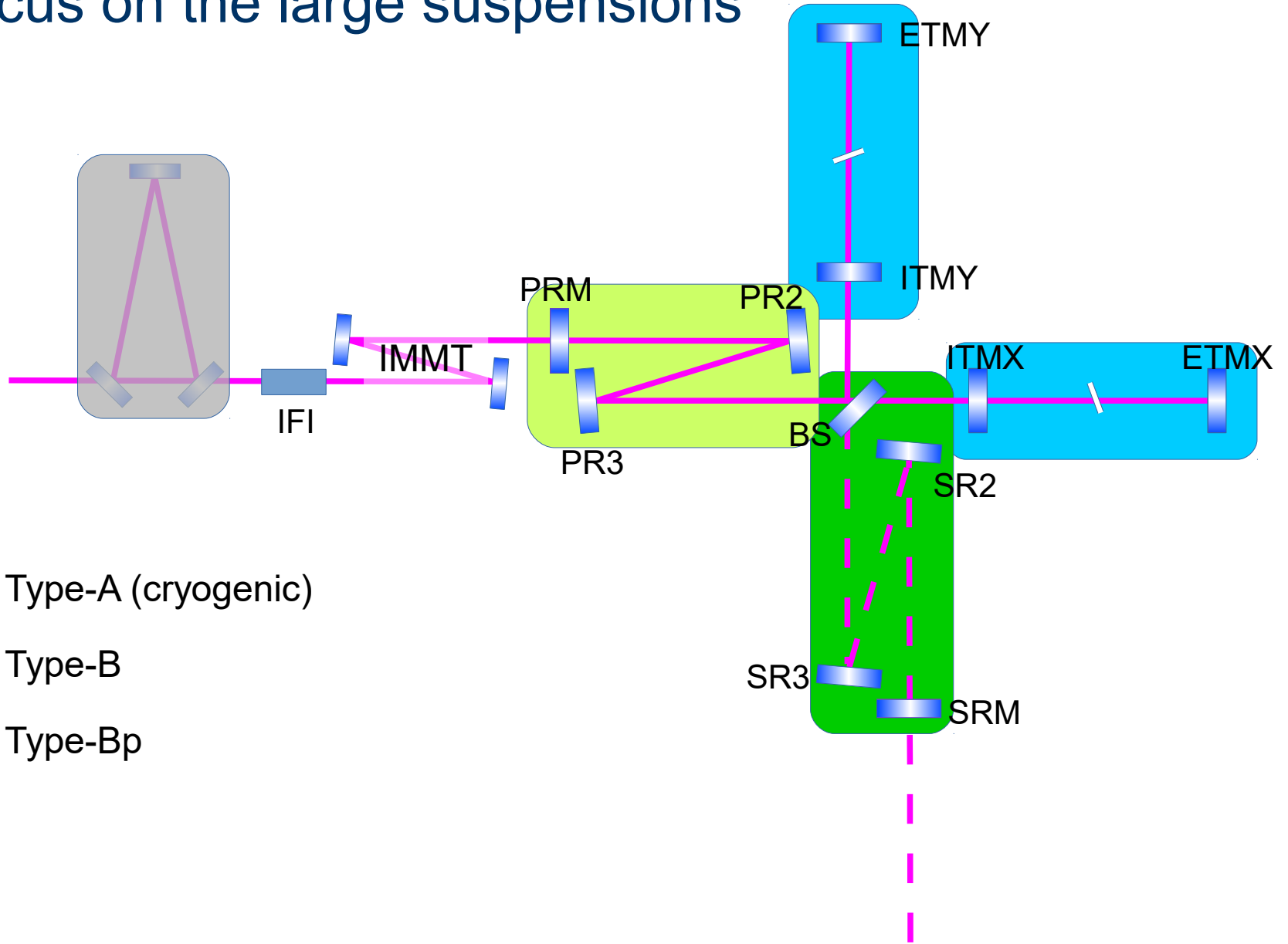

- Type-A (cryogenic)
- Type-B
- Type-Bp

Overall Schedule

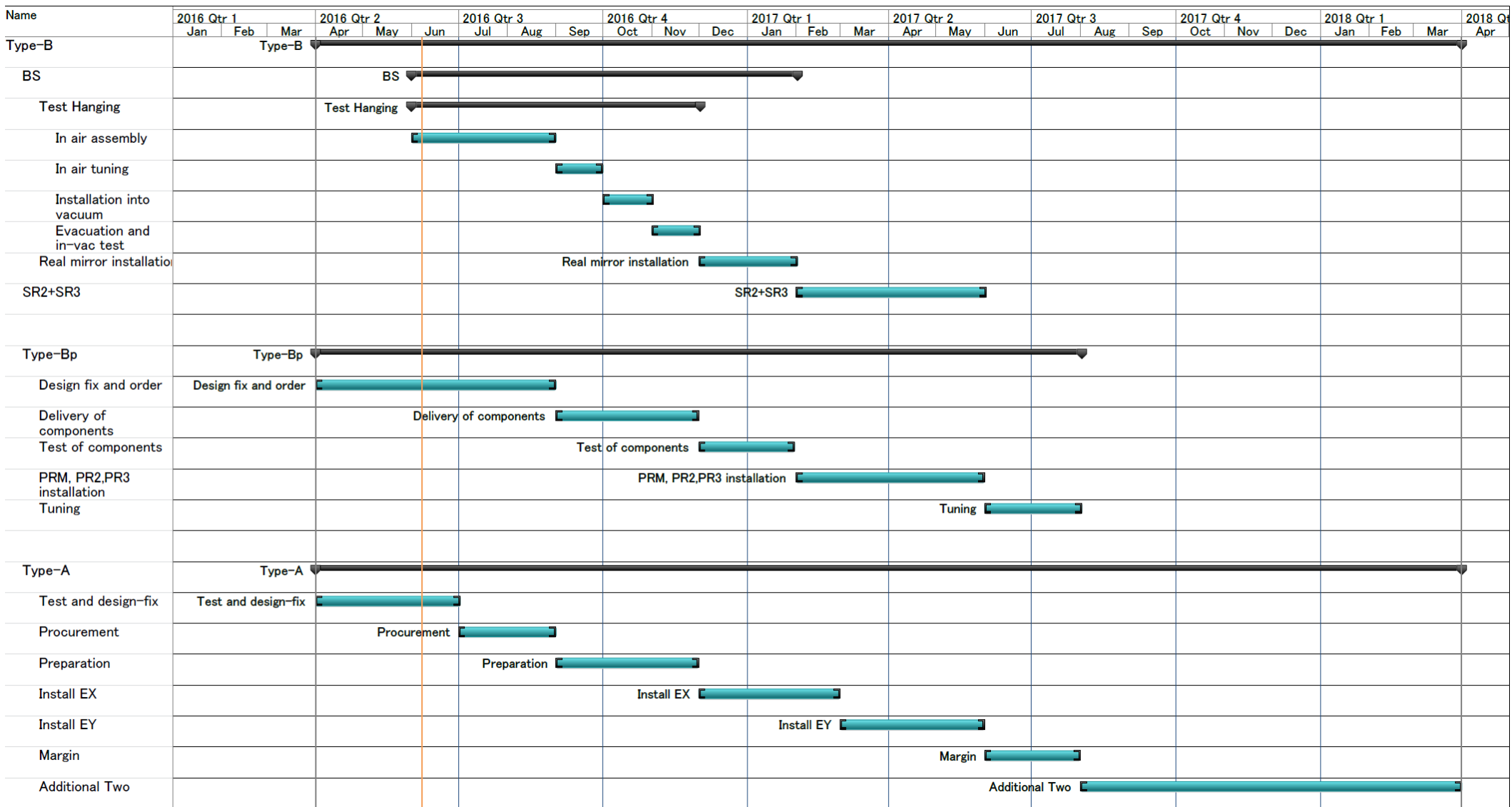

VIS team organization

Three teams

Type-A: 1 scientist, 2 engineers, 1 student

Type-B: 2 scientist, 1 engineer

Type-Bp: 1(+1) scientist, 1 student, (1 engineer)

Preparation status

Type-A

- Suspension components are mostly ready
- Installation procedure is being tested
- Some local sensors needs to be added
- Installation will start from Dec. 2016

Type-B

- Most of the components are ready except for two additional payloads
- Installation procedure is being finalized
- Start the test installation from July

Type-Bp

- Additional sensors/actuators need to be retrofitted to damp some resonances
- Except for the modifications above, most of the suspension components are ready
- Installation will start from Feb. 2017

Technical Issues

Type-Bp damping issue

- No inverted pendulum
- A high Q mode survives

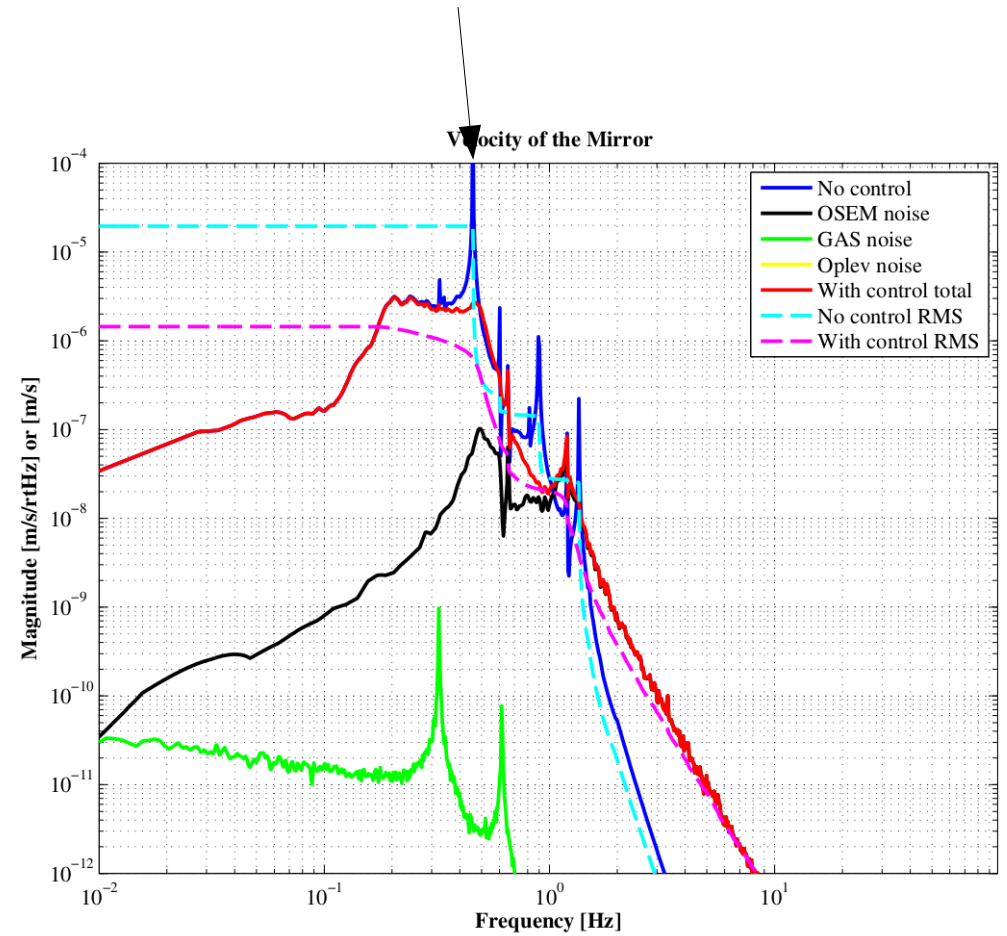
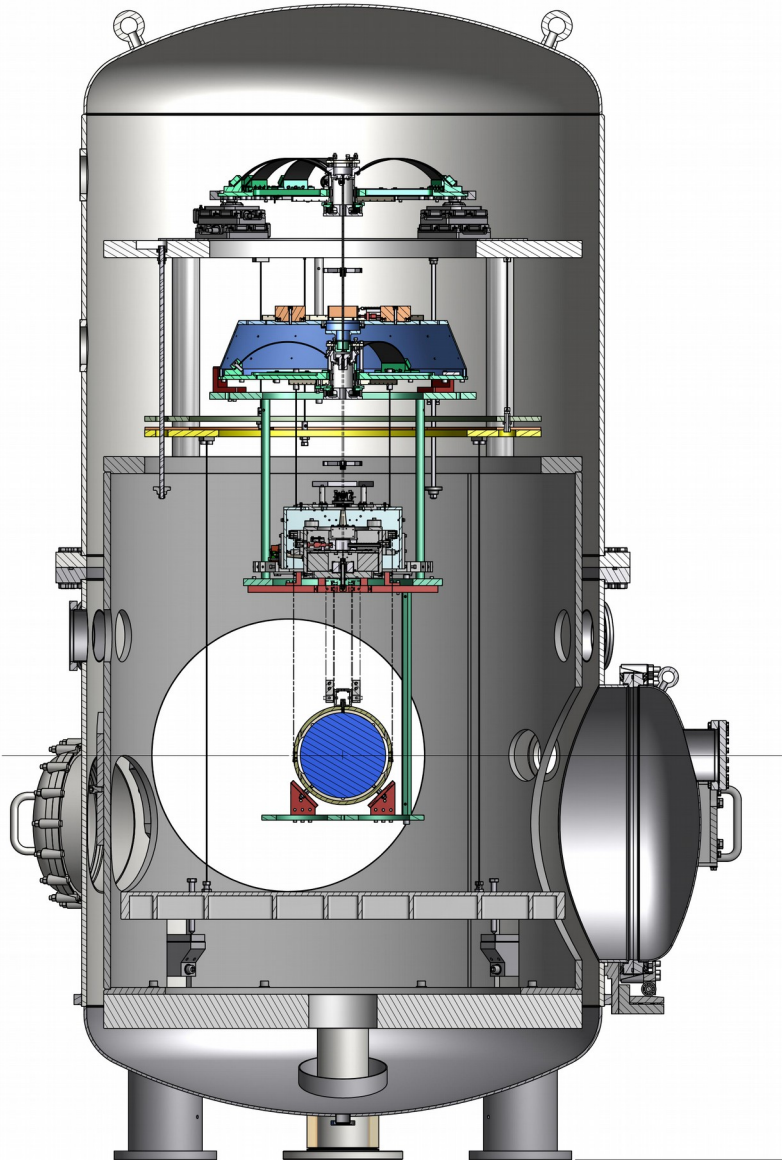

Type-Bp damping issue

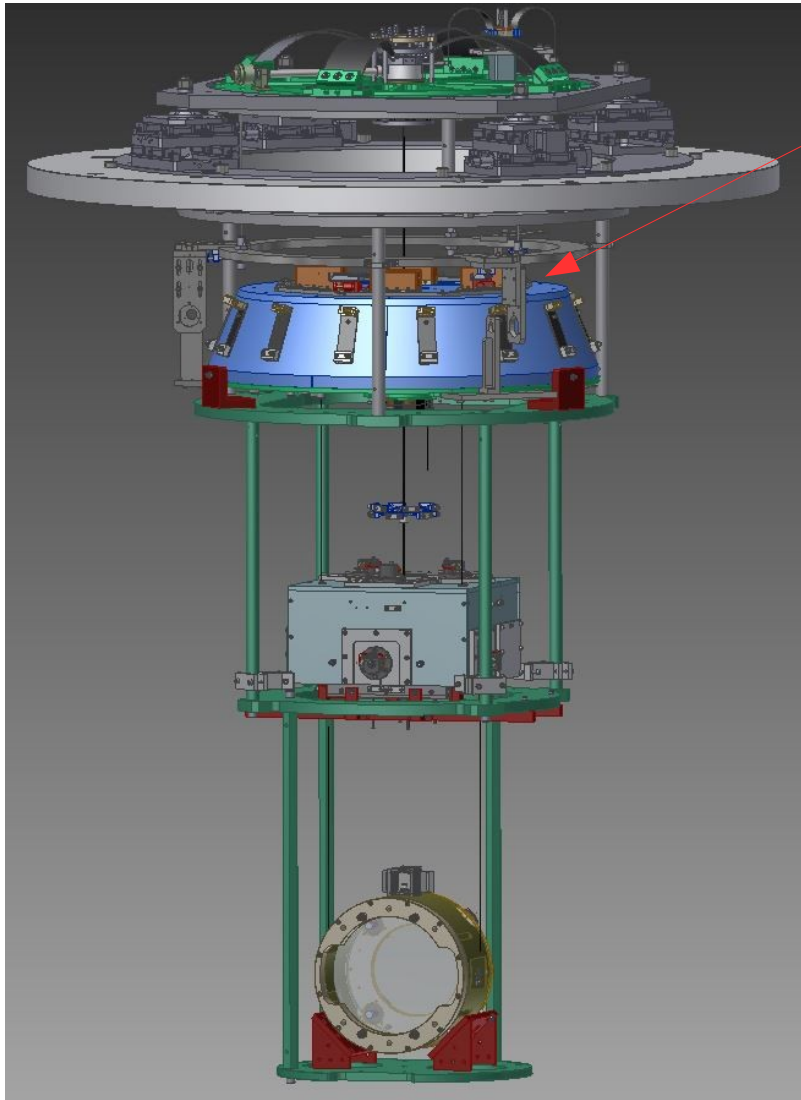

- Additional sensors/actuators
- Active damping on the bottom filter
- Reduced RMS

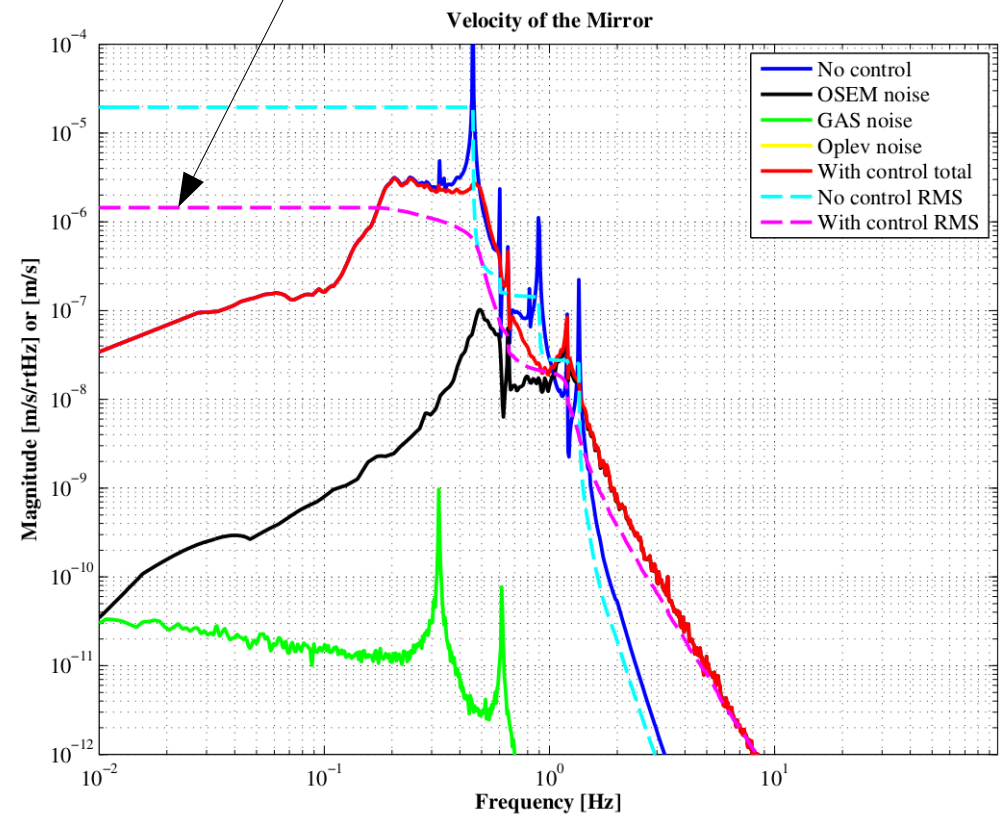

Better inertial sensors for the pre-isolators ? (Type-B and Type-A)

- Original plan: Use Geophones
 - The noise may not be good enough
- Alternative options: Accelerometers by NIKHEF
 - Being tested with BS

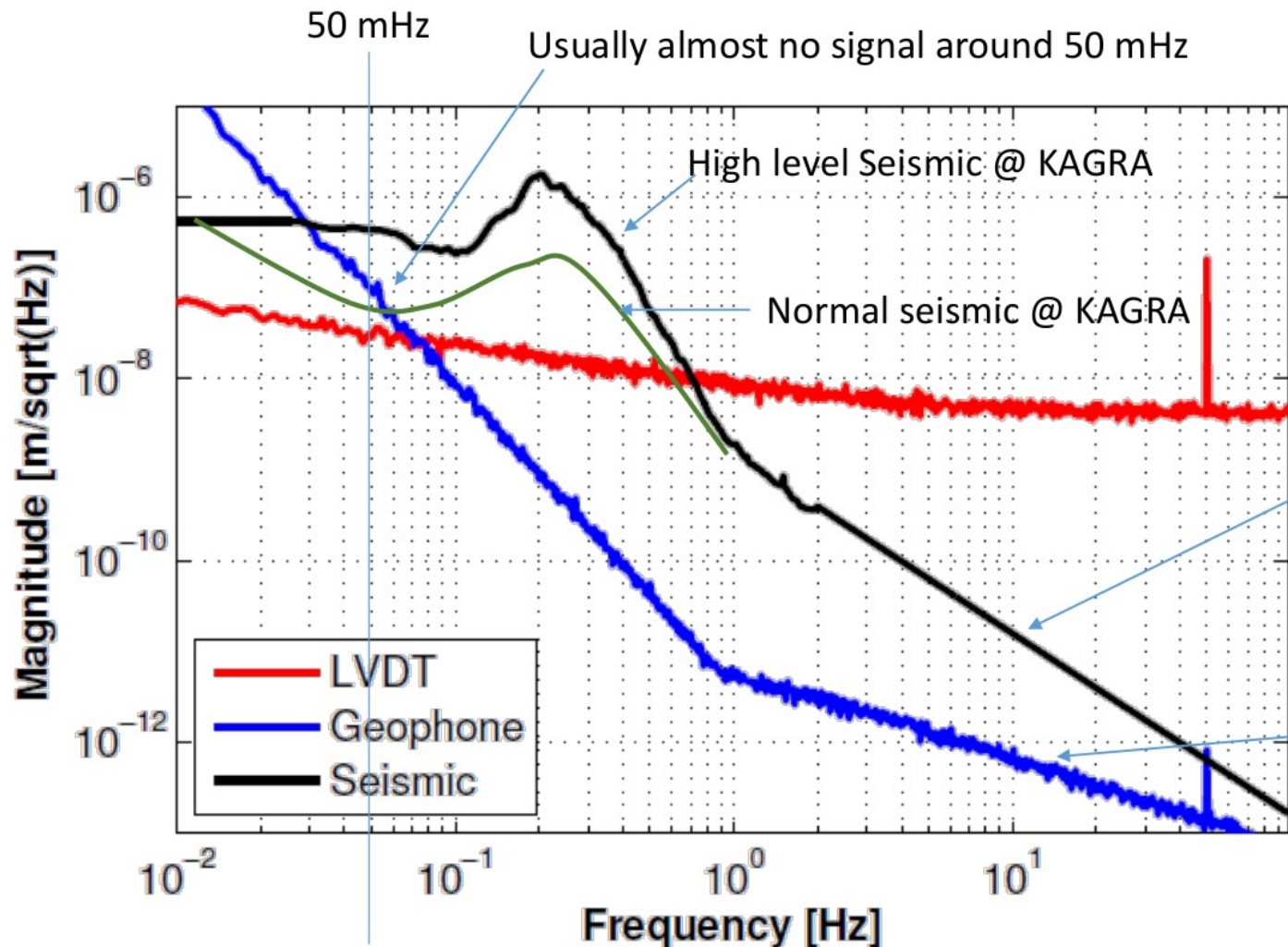

OSEM flags are huge

- We broke them during the suspension assembly work
- Thermal noise concern
-> calculation says barely OK

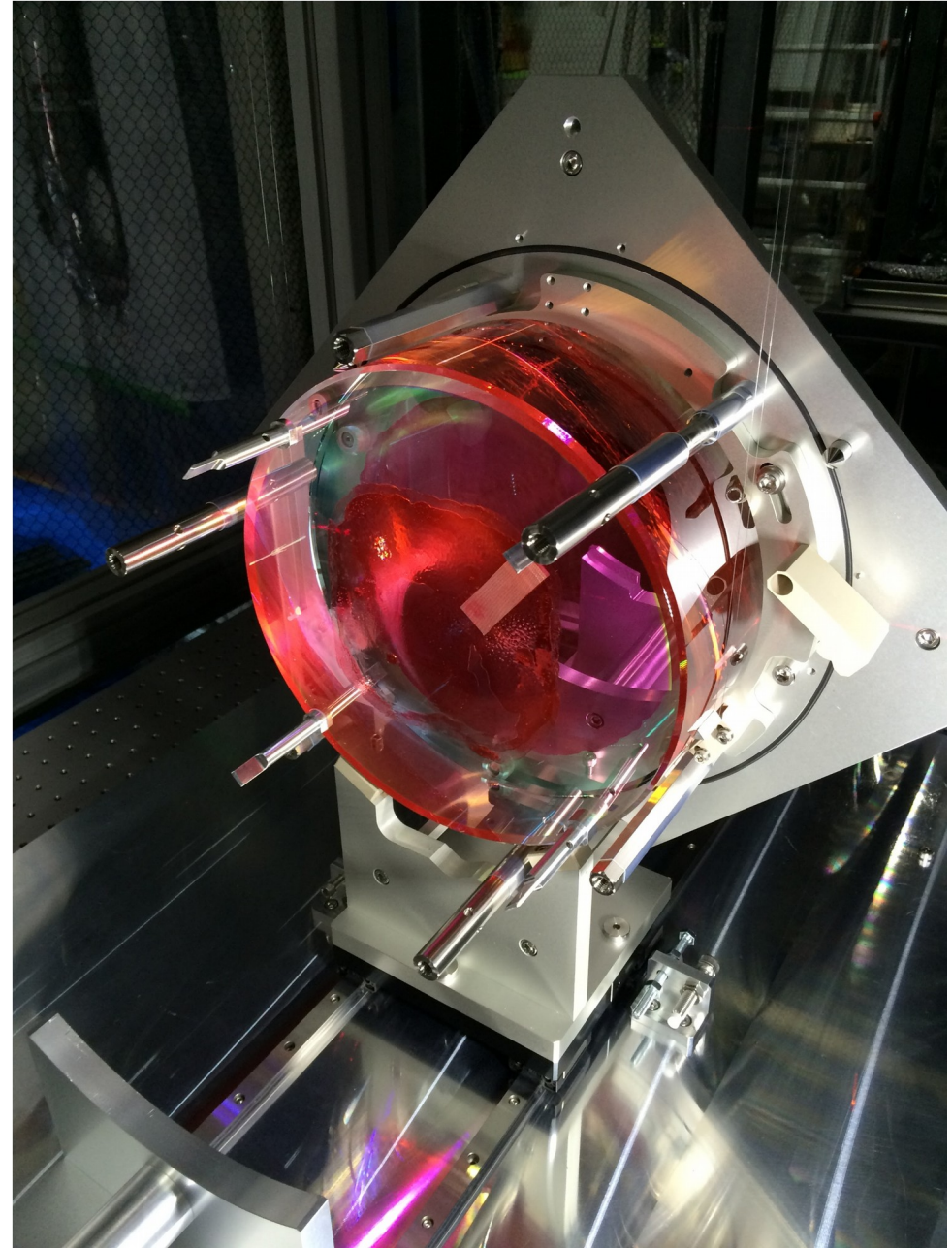

Decided to remove the flags from the optics

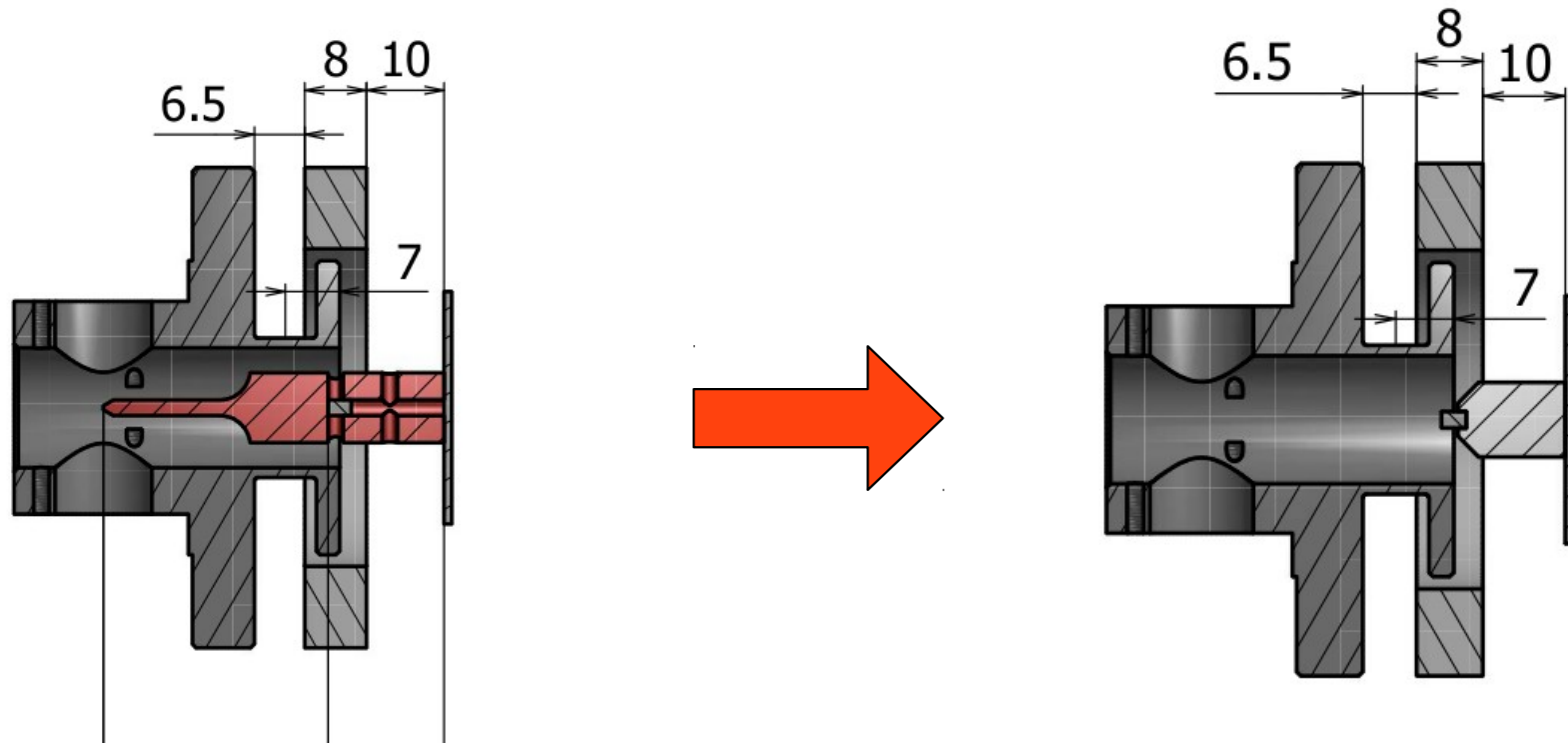

- No sensing. Only actuation.
- Use an optical lever instead
 - Two QPDs at different Gouy phases to sense the longitudinal motion

Wider gap OSEMs for IM

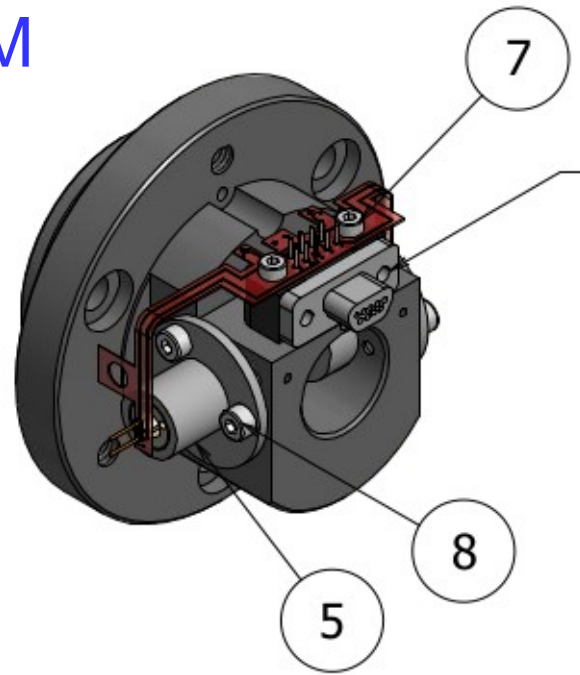

Narrow

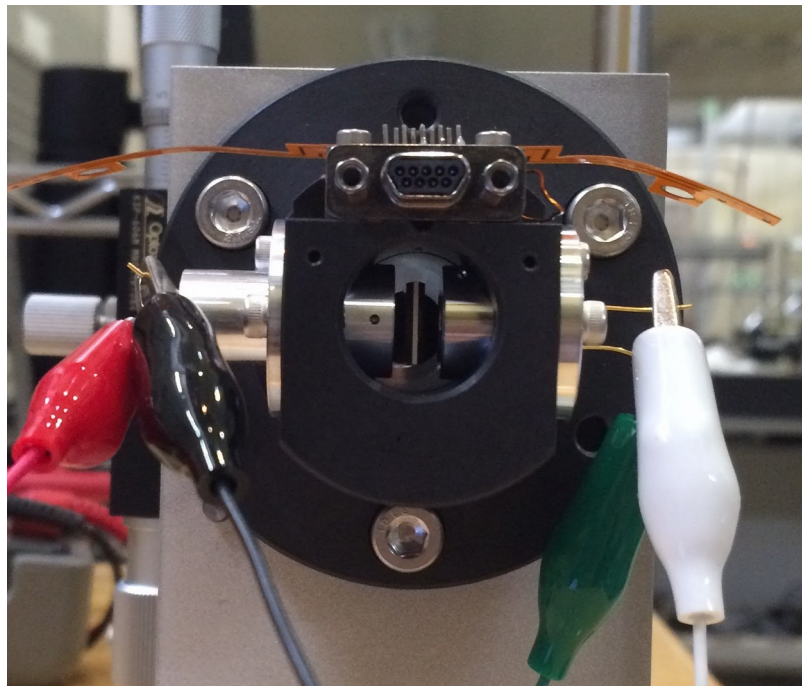

Wide

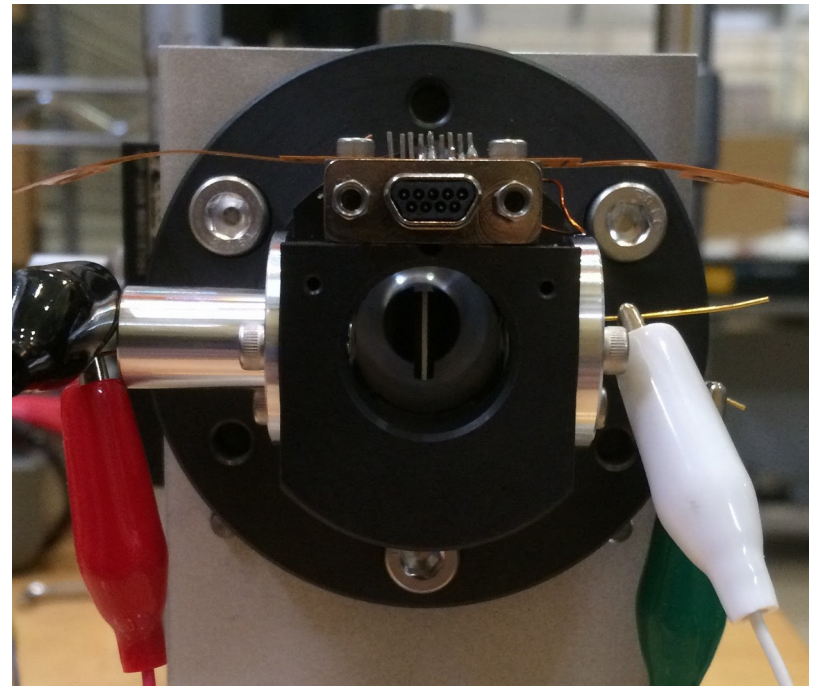

bKAGRA phase 1

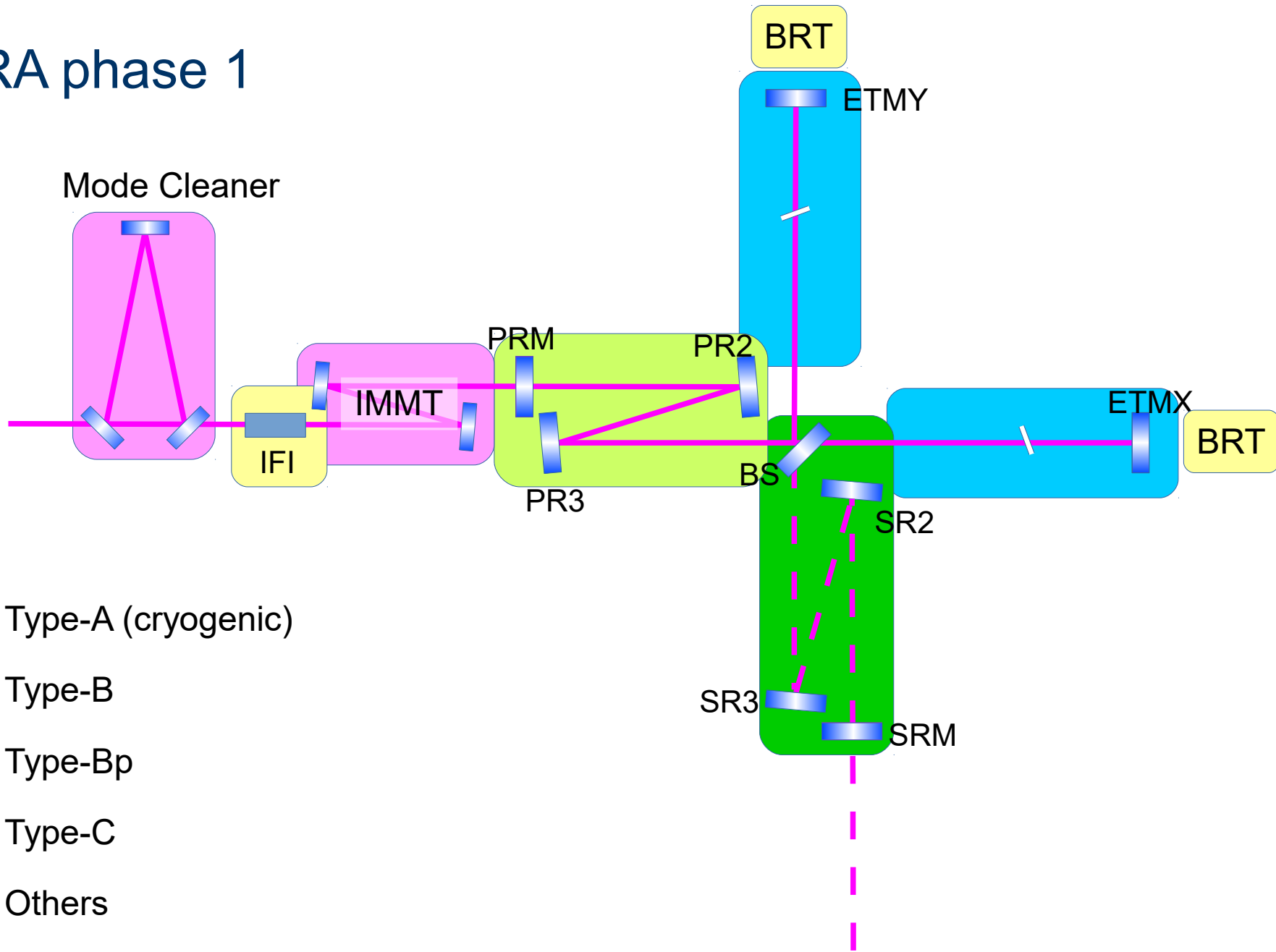

Before bKAGRA phase 1

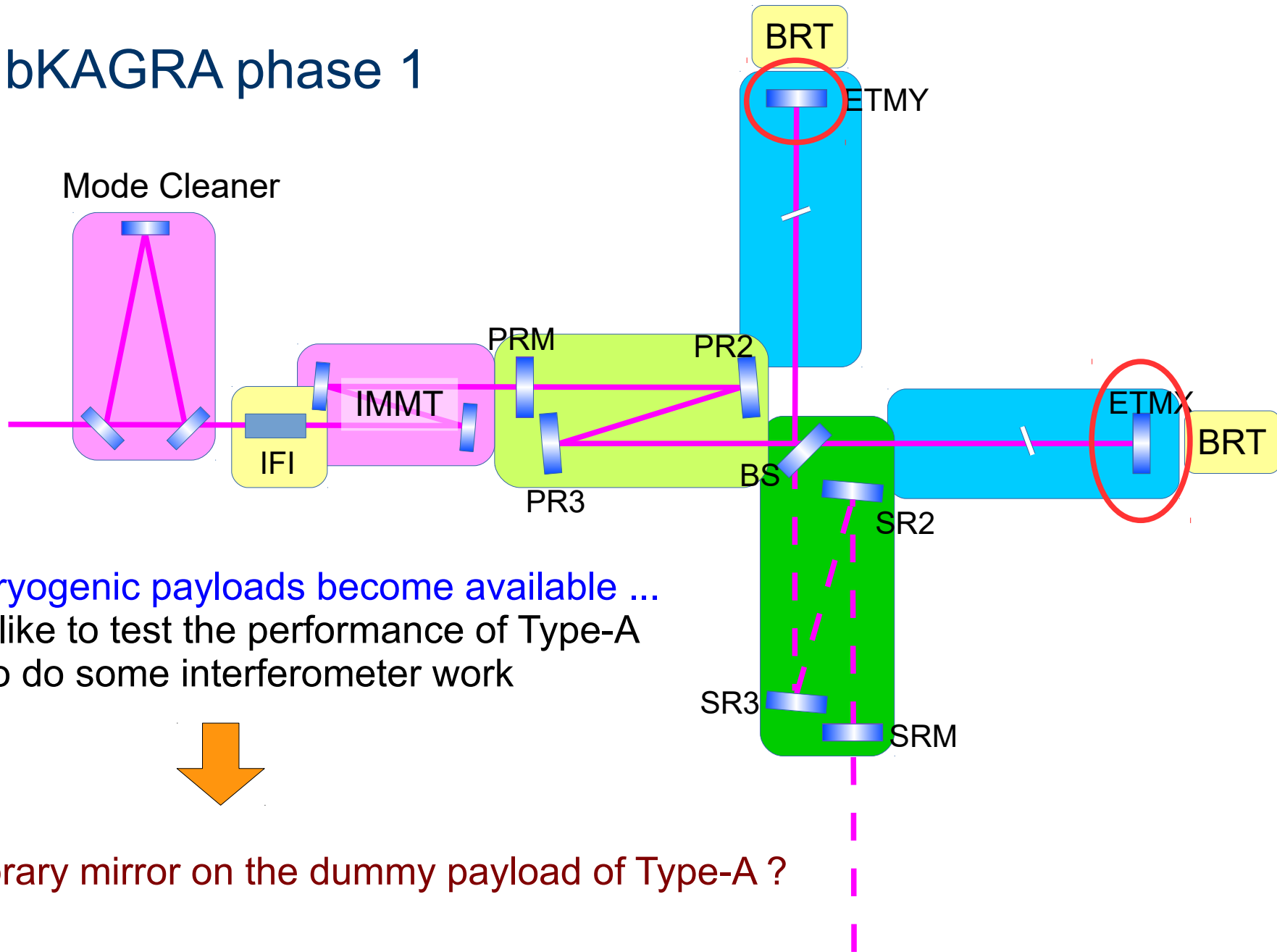

Before the cryogenic payloads become available ...

- We would like to test the performance of Type-A
- We want to do some interferometer work

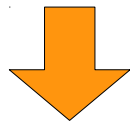

Put a temporary mirror on the dummy payload of Type-A ?