

TypeBp with IP, MD

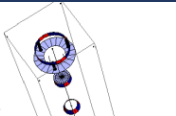

Mechanical response

Calculated by SUMCON (and Simulink)

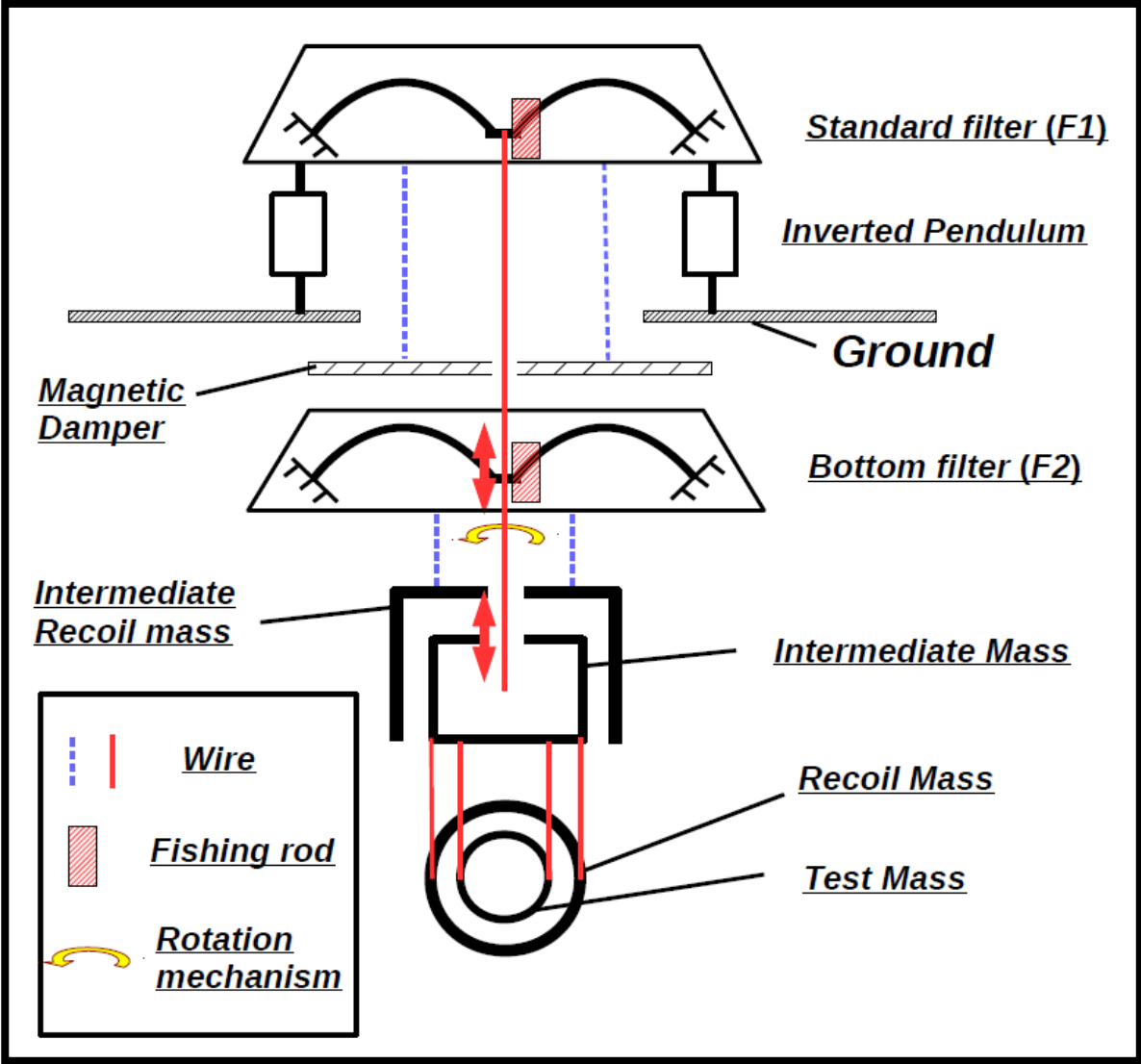
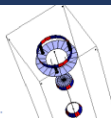



TypeBp with IP, MD 160328

Model Basic Information

Degrees of Freedom:

39 State Variables
6 Input Variables
2 Float Variables

Ground Position:

$x_g \rightarrow 0.$ $y_g \rightarrow 0.$ $z_g \rightarrow 0.$ $pitch_g \rightarrow 0.$ $yaw_g \rightarrow 0.$ $roll_g \rightarrow 0.$

Equilibrium Point:

$x_{F2} \rightarrow 0.$	$y_{F2} \rightarrow -0.1444$	$z_{F2} \rightarrow 0.$	$pitch_{F2} \rightarrow 0.$	$yaw_{F2} \rightarrow 0.$	$roll_{F2} \rightarrow 0.$
$x_{IR} \rightarrow 0.$	$y_{IR} \rightarrow -0.647$	$z_{IR} \rightarrow 0.$	$pitch_{IR} \rightarrow 0.$	$yaw_{IR} \rightarrow 0.$	$roll_{IR} \rightarrow 0.$
$x_{IM} \rightarrow 0.$	$y_{IM} \rightarrow -0.6977$	$z_{IM} \rightarrow 0.$	$pitch_{IM} \rightarrow 0.$	$yaw_{IM} \rightarrow 0.$	$roll_{IM} \rightarrow 0.$
$x_{RM} \rightarrow 0.$	$y_{RM} \rightarrow -1.2847$	$z_{RM} \rightarrow 0.$	$pitch_{RM} \rightarrow 0.$	$yaw_{RM} \rightarrow 0.$	$roll_{RM} \rightarrow 0.$
$x_{TM} \rightarrow 0.$	$y_{TM} \rightarrow -1.2848$	$z_{TM} \rightarrow 0.$	$pitch_{TM} \rightarrow 0.$	$yaw_{TM} \rightarrow 0.$	$roll_{TM} \rightarrow 0.$
$x_{F1} \rightarrow 0.$	$z_{F1} \rightarrow 0.$	$yaw_{F1} \rightarrow 0.$	$x_{MD} \rightarrow 0.$	$y_{MD} \rightarrow 0.0399$	$z_{MD} \rightarrow 0.$
$pitch_{MD} \rightarrow 0.$	$yaw_{MD} \rightarrow 0.$	$roll_{MD} \rightarrow 0.$	$h_{GAS2} \rightarrow 0.0259$	$h_{GAS1} \rightarrow -0.0839$	

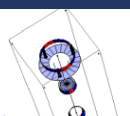
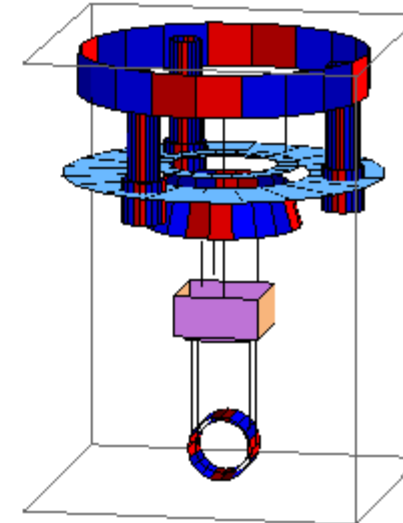

Eigen Mode List

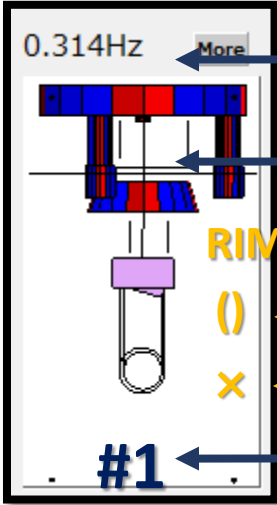

Resonance frequency

Eigen mode shape

Sensing / Excitation point

Hardly seen/excited

Cannot be seen/excited

Eigen mode number

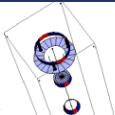

Eigen Mode Shape

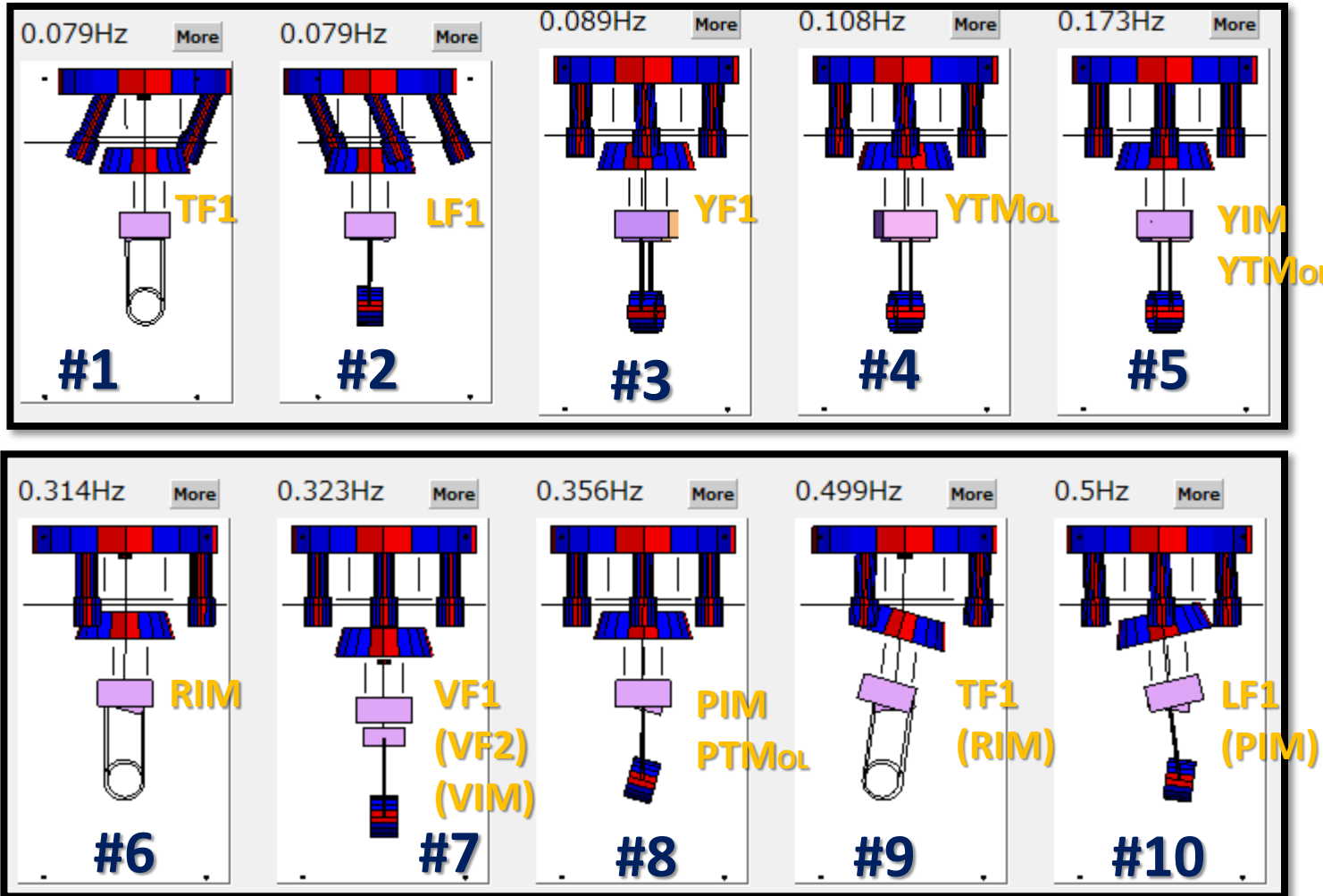

#1 : TF0

#2 : LF0

#3 : YF0

#4 : YWholeChain

#5 : YPayload

#6 : RPayload

#7 : VPayload

#8 : PPayload

#9 : TPendulum

#10 : LPendulum

Eigen Mode Shape

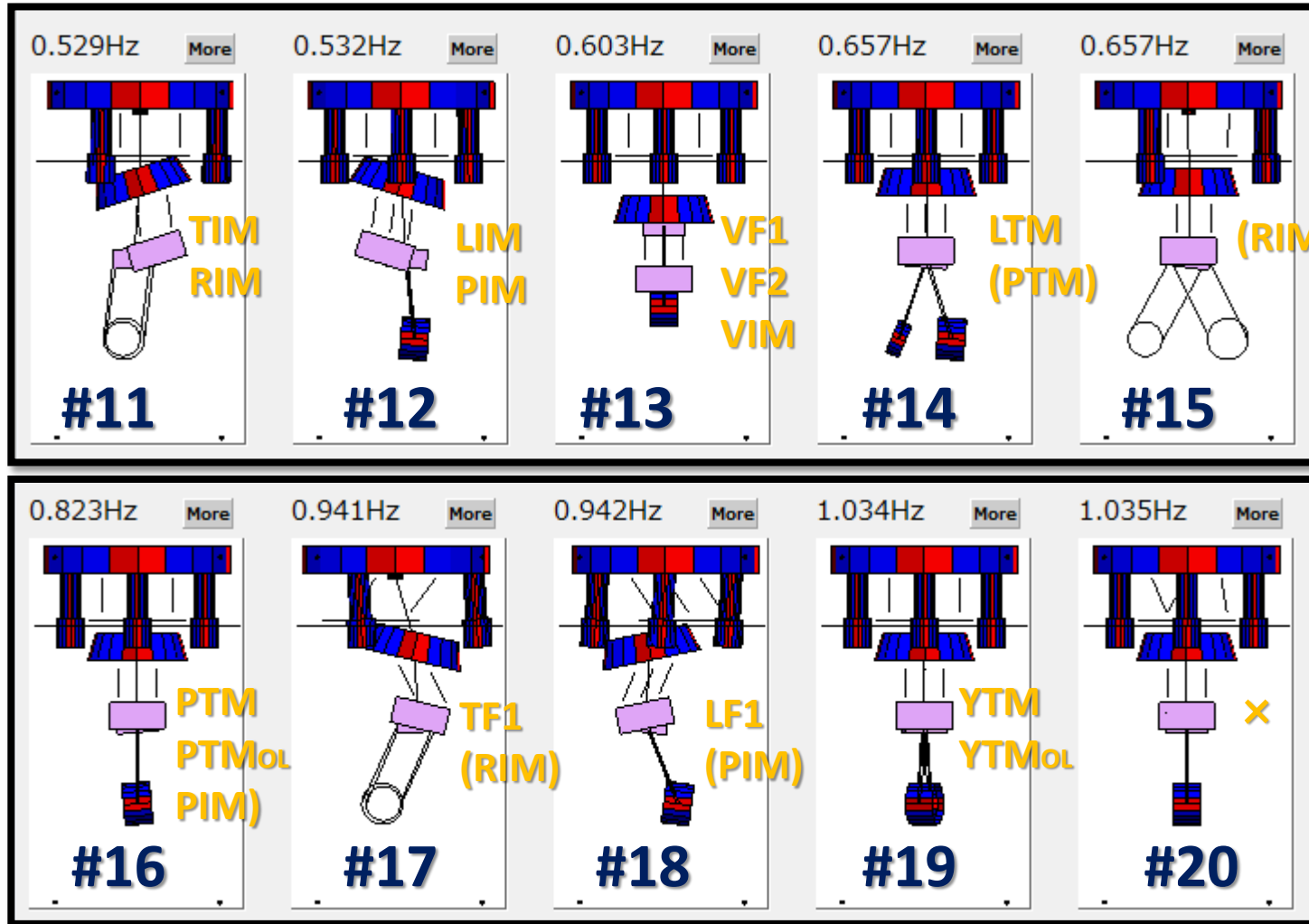

#11 : RF2

#12 : PF2

#13 : GAS

#14 : LTM

#15 : TTM

#16 : PTM

#17 : TPendulum

#18 : LPendulum

#19 : YTM, YRM
(YTM, -YRM)

#20 : YMD

Eigen Mode Shape

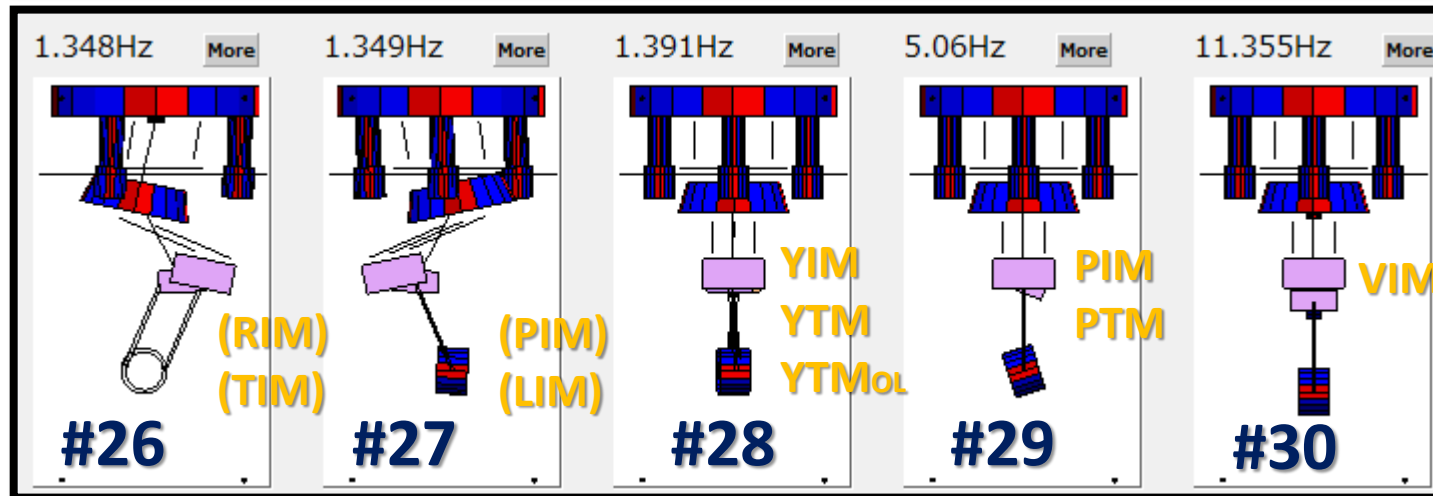
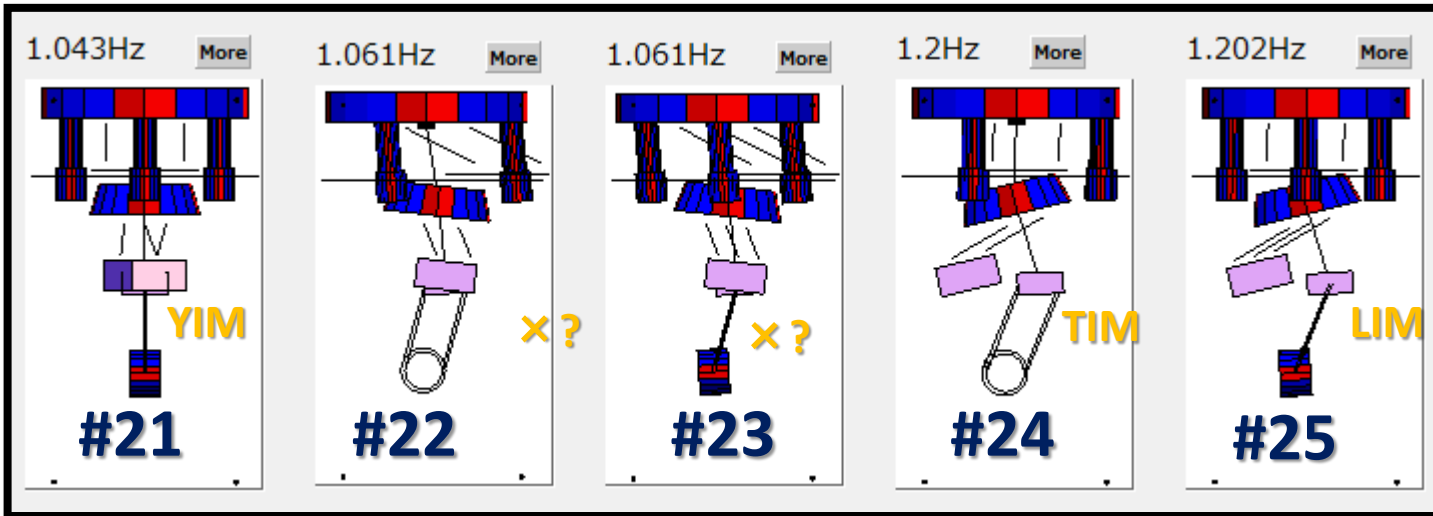

#21 : YIR

#22 : TMD

#23 : LMD

#24 : TIR

#25 : LIR

#26 : TPendulum

#27 : LPendulum

#28 : YTM

#29 : PIM, PRM

#30 : VTM

Eigen Mode Shape

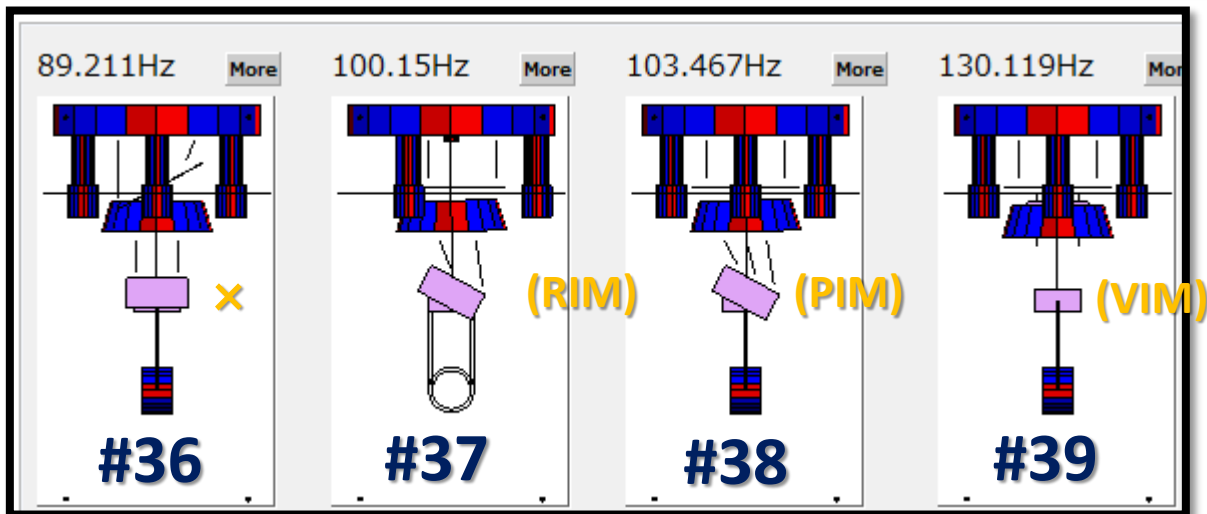
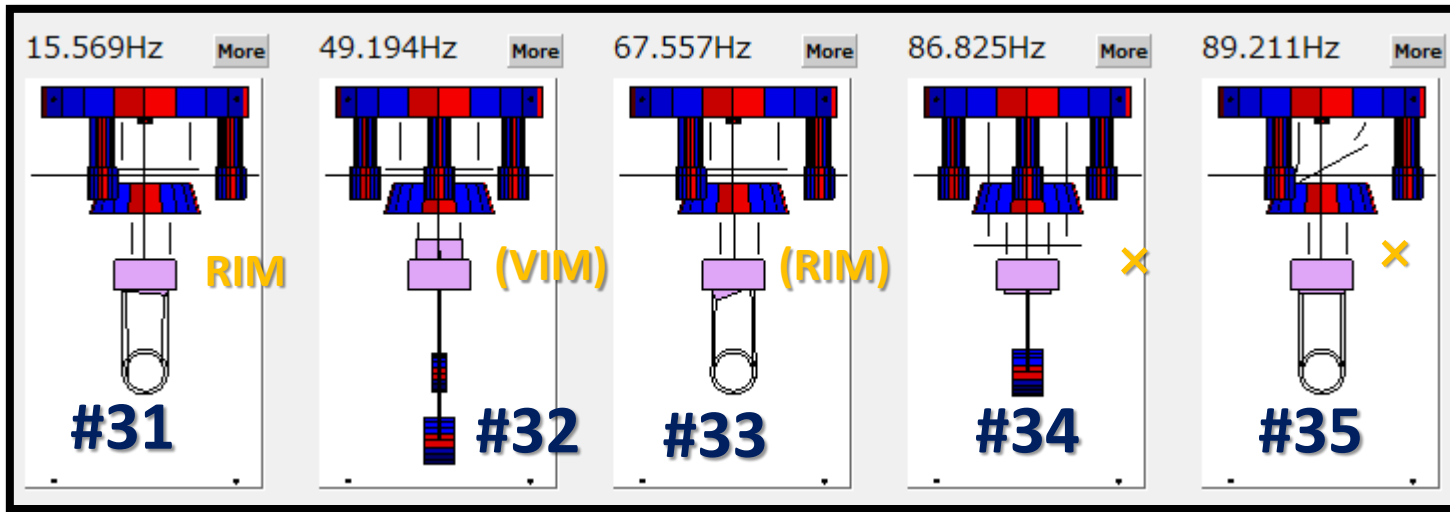

#31 : RTM

#32 : VRM

#33 : RIM, RRM
(RIM, -RRM)

#34 : VMD

#35 : RMD

#36 : PMD

#37 : RIR

#38 : PIR

#39 : VIR

Force Transfer Functions

(, which can be measured, with No ctrl)

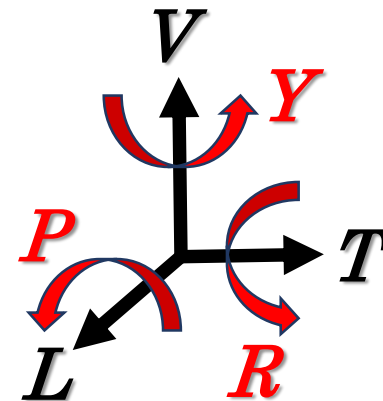
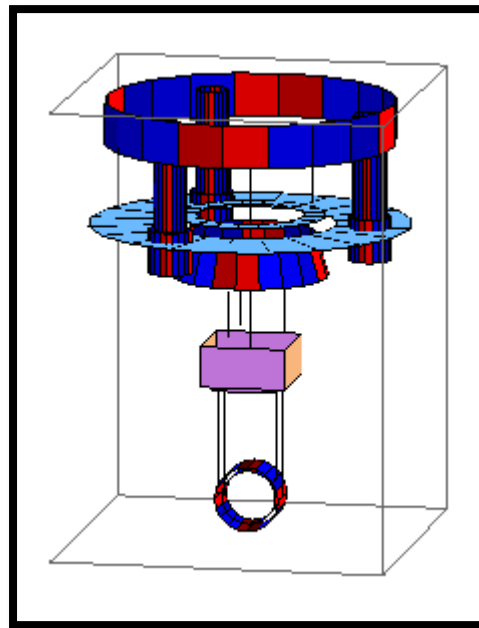

Force Transfer Function

LVDT_LF1 / actLF1

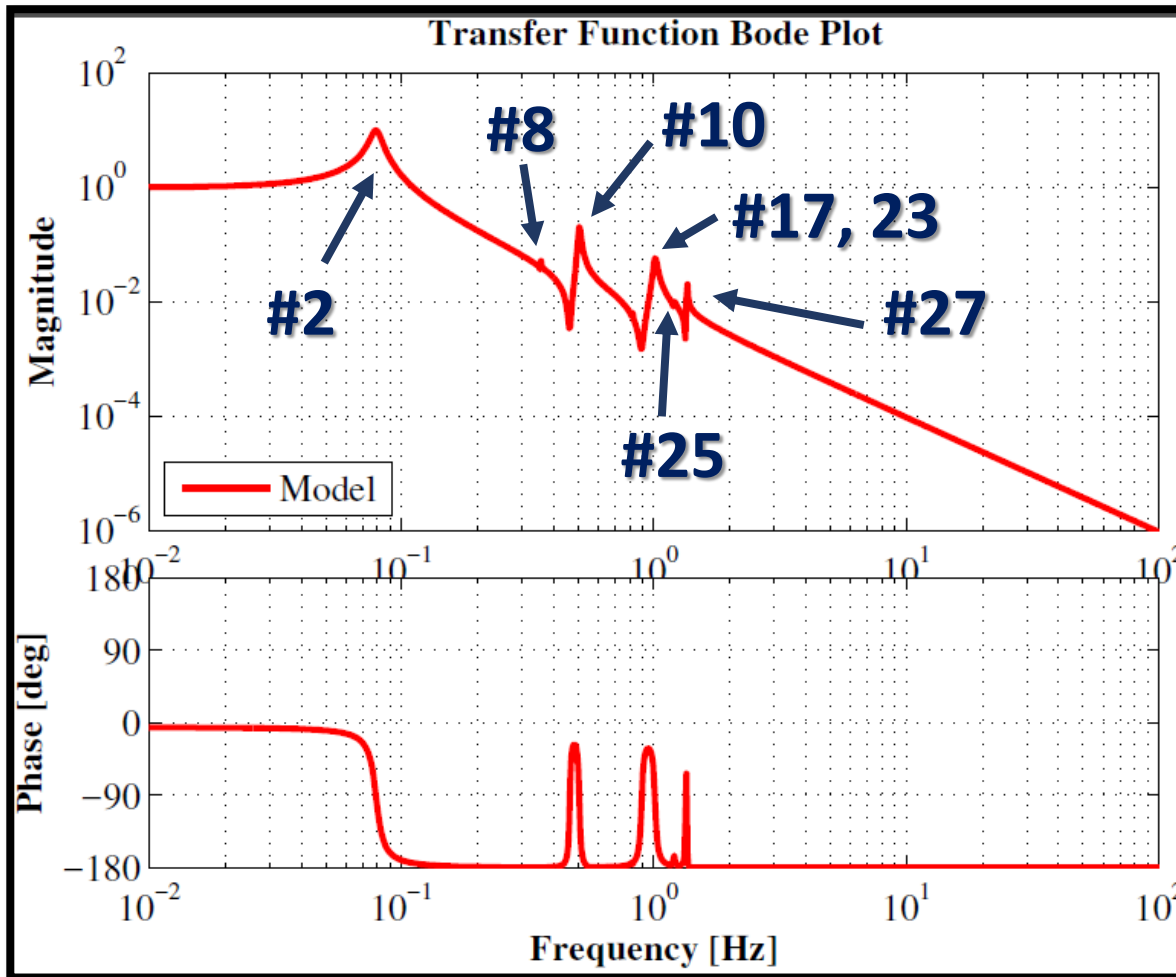
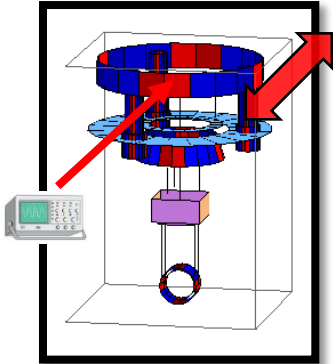

Force Transfer Function

LVDT_TF1 / actTF1

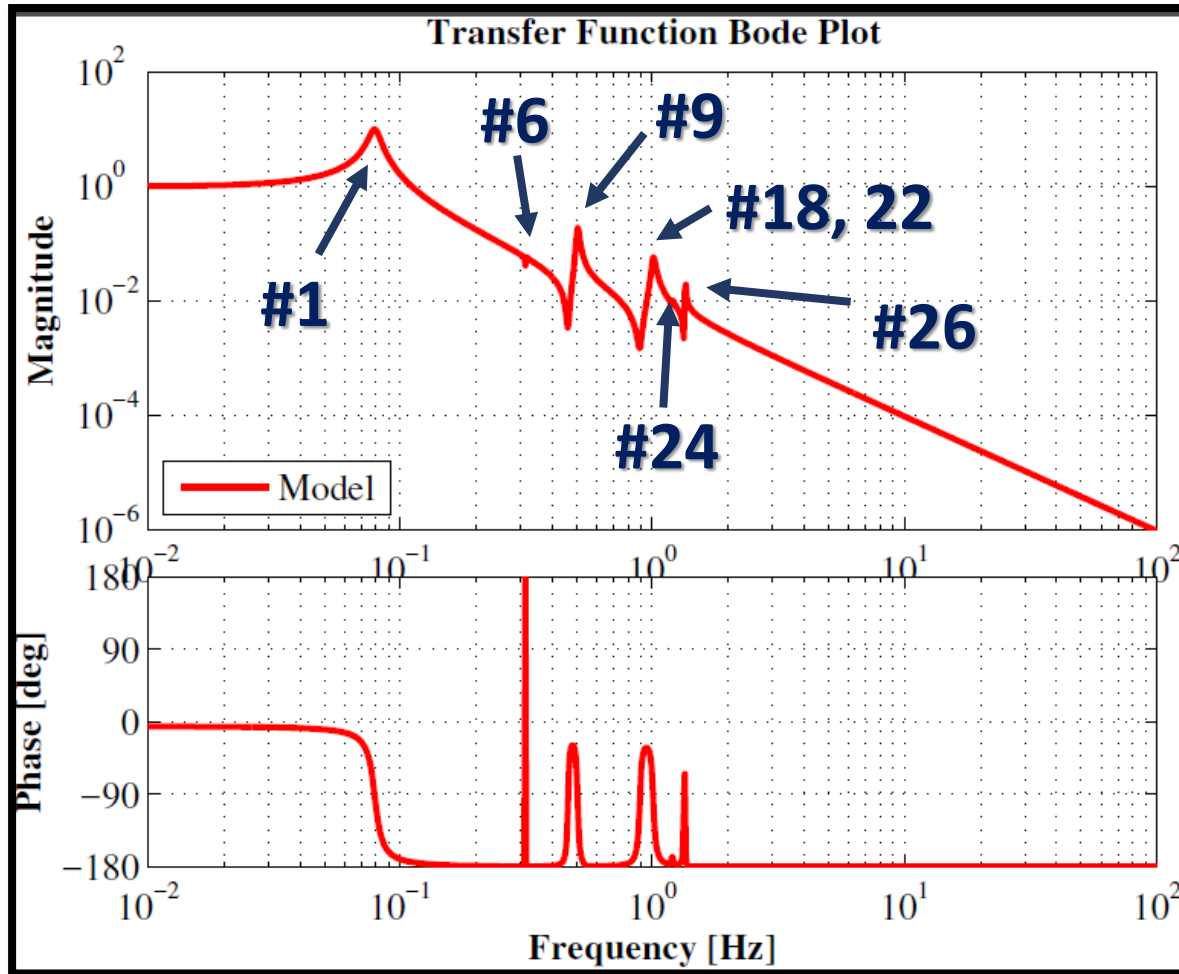
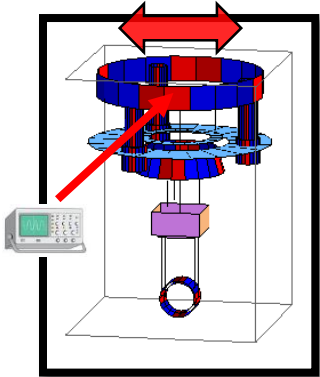

Force Transfer Function

LVDT_YF1 / actYF1

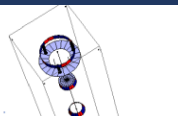
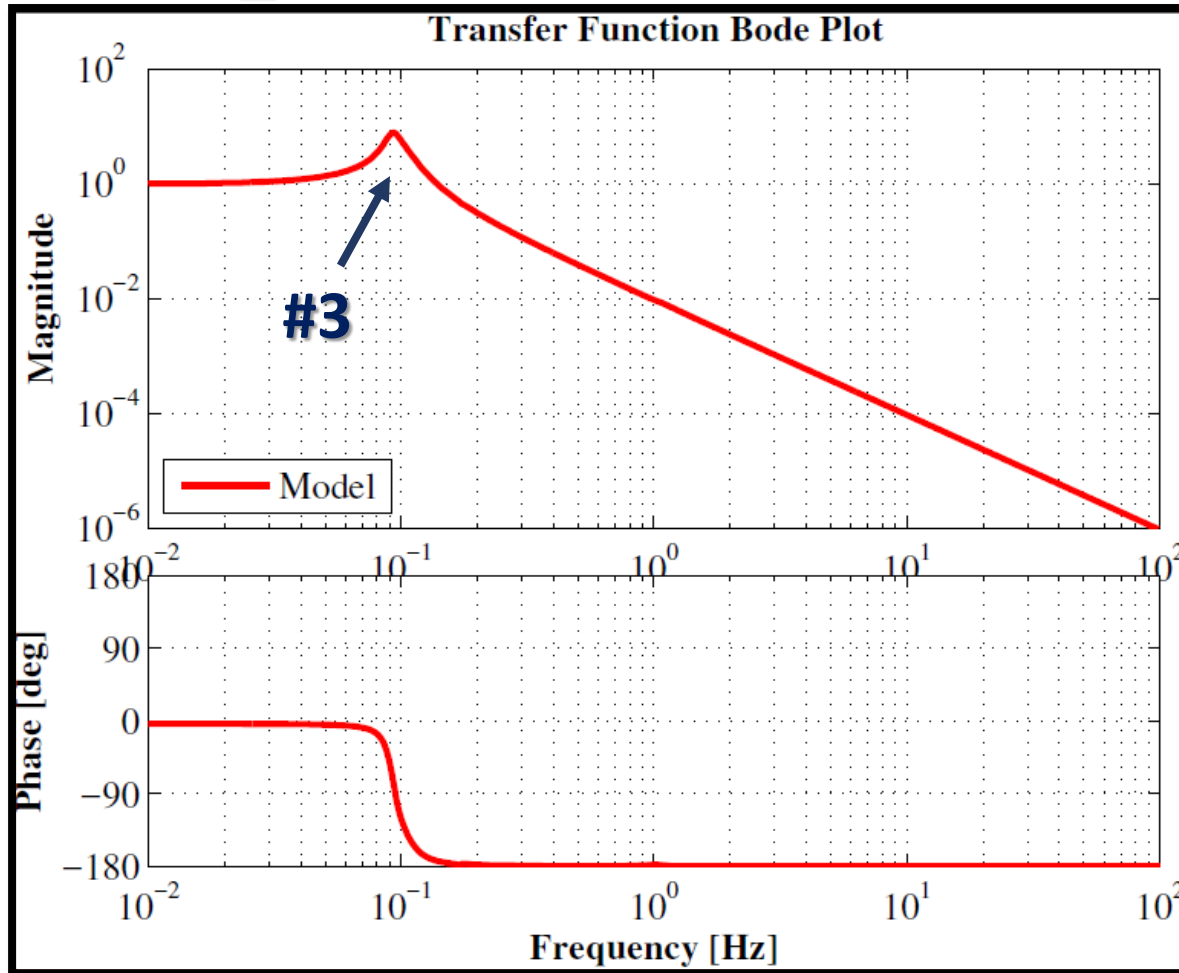
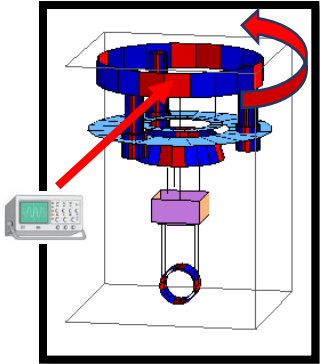

Force Transfer Function

LVDT_VF1 / actVF1

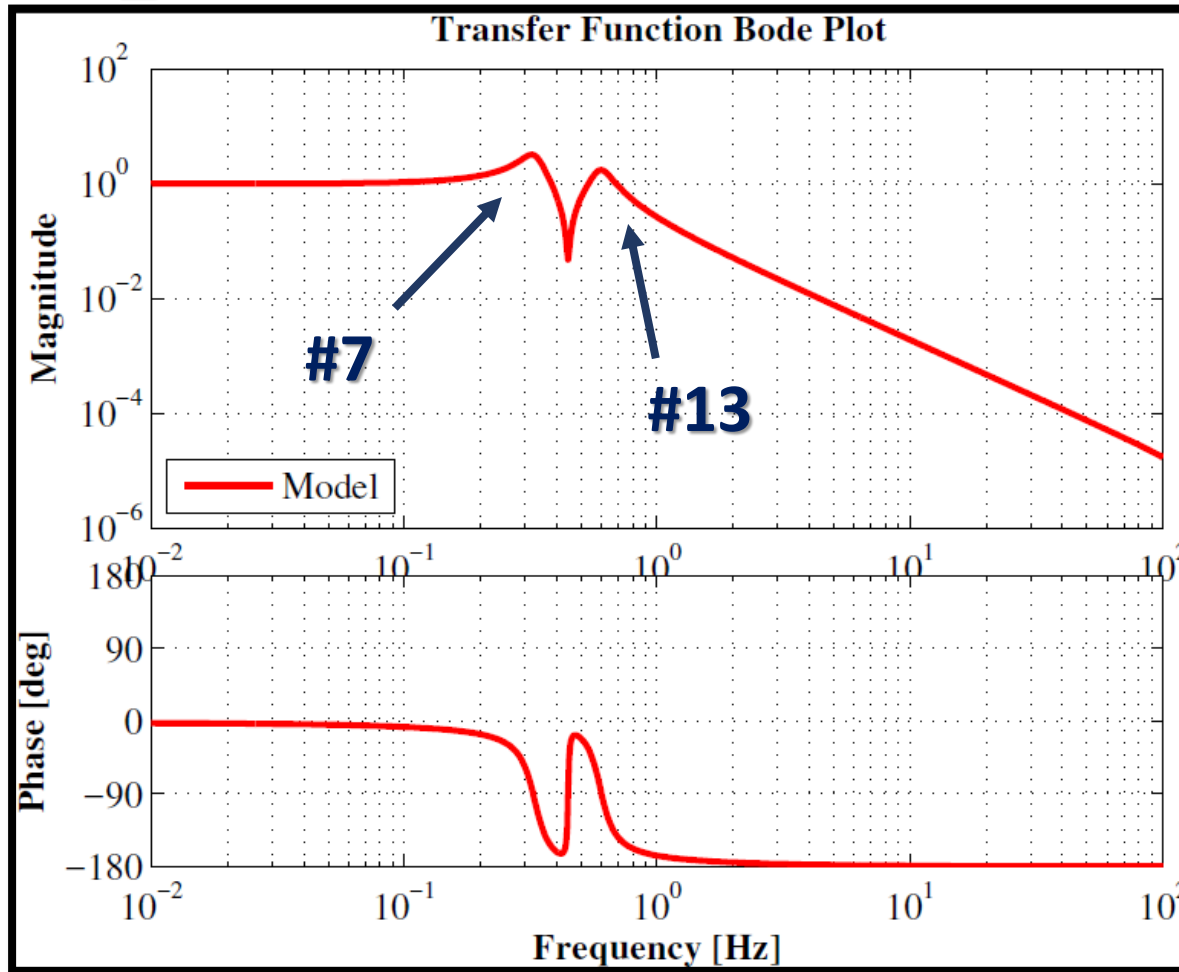
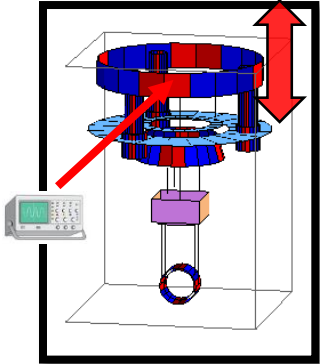

Force Transfer Function

LVDT_VF2 / actVF2

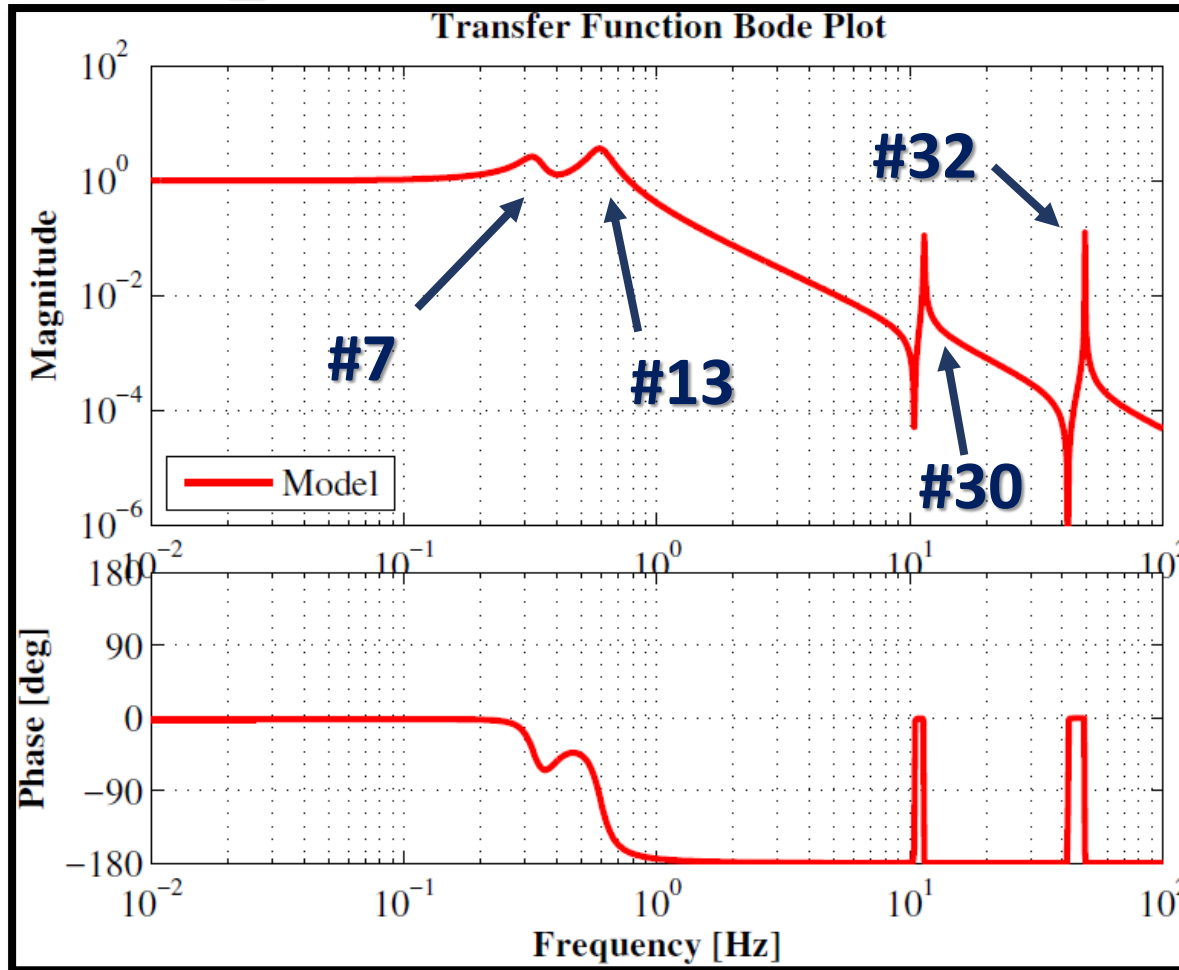
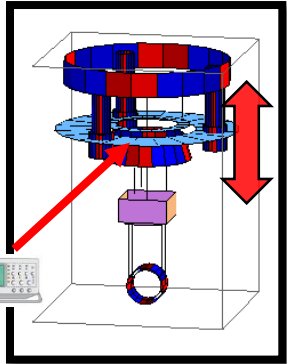

Force Transfer Function

OSEM_LIM / actLIM

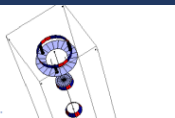
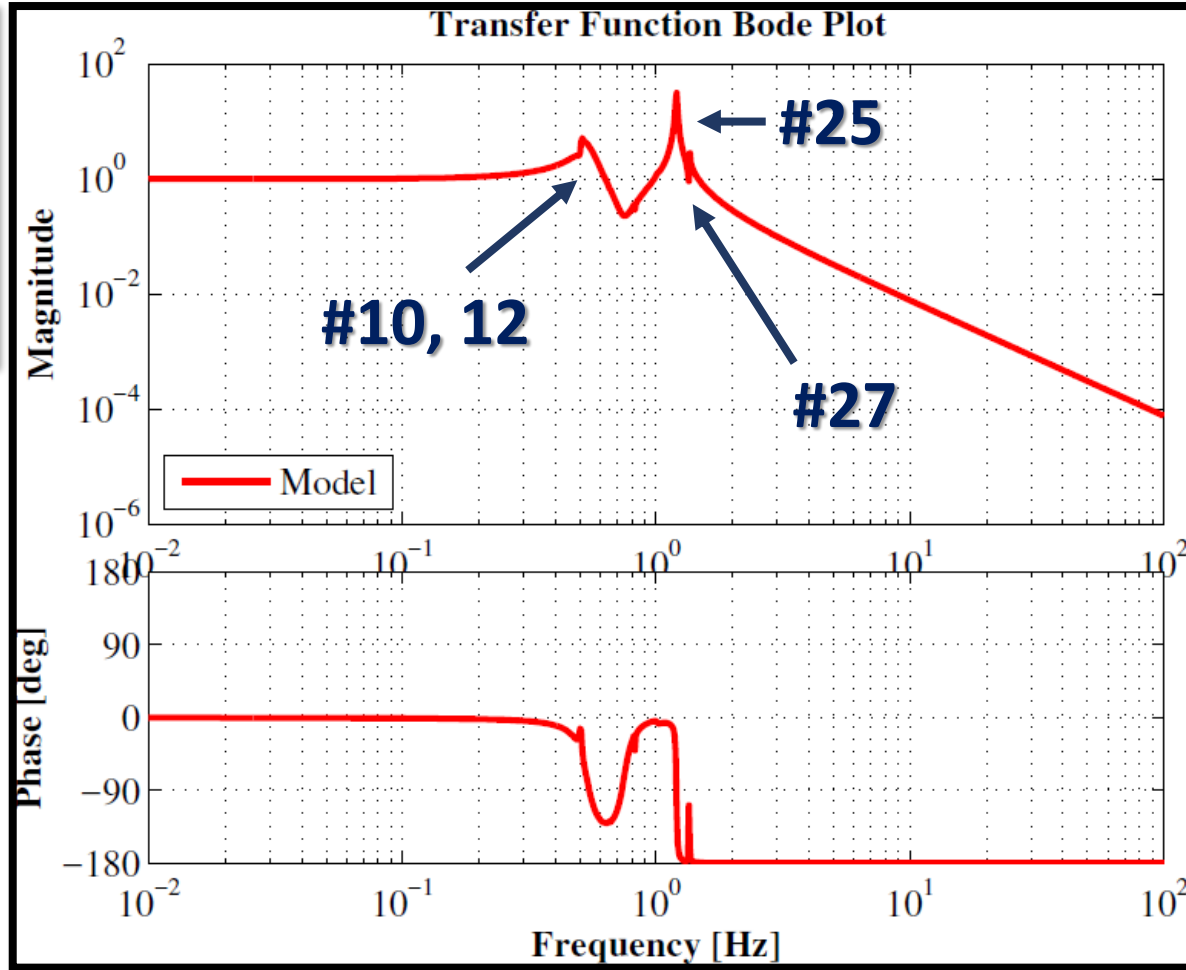
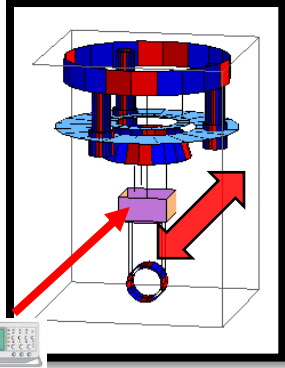

Force Transfer Function

OSEM_TIM / actTIM

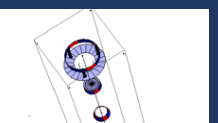
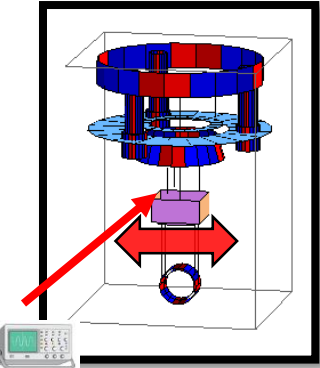
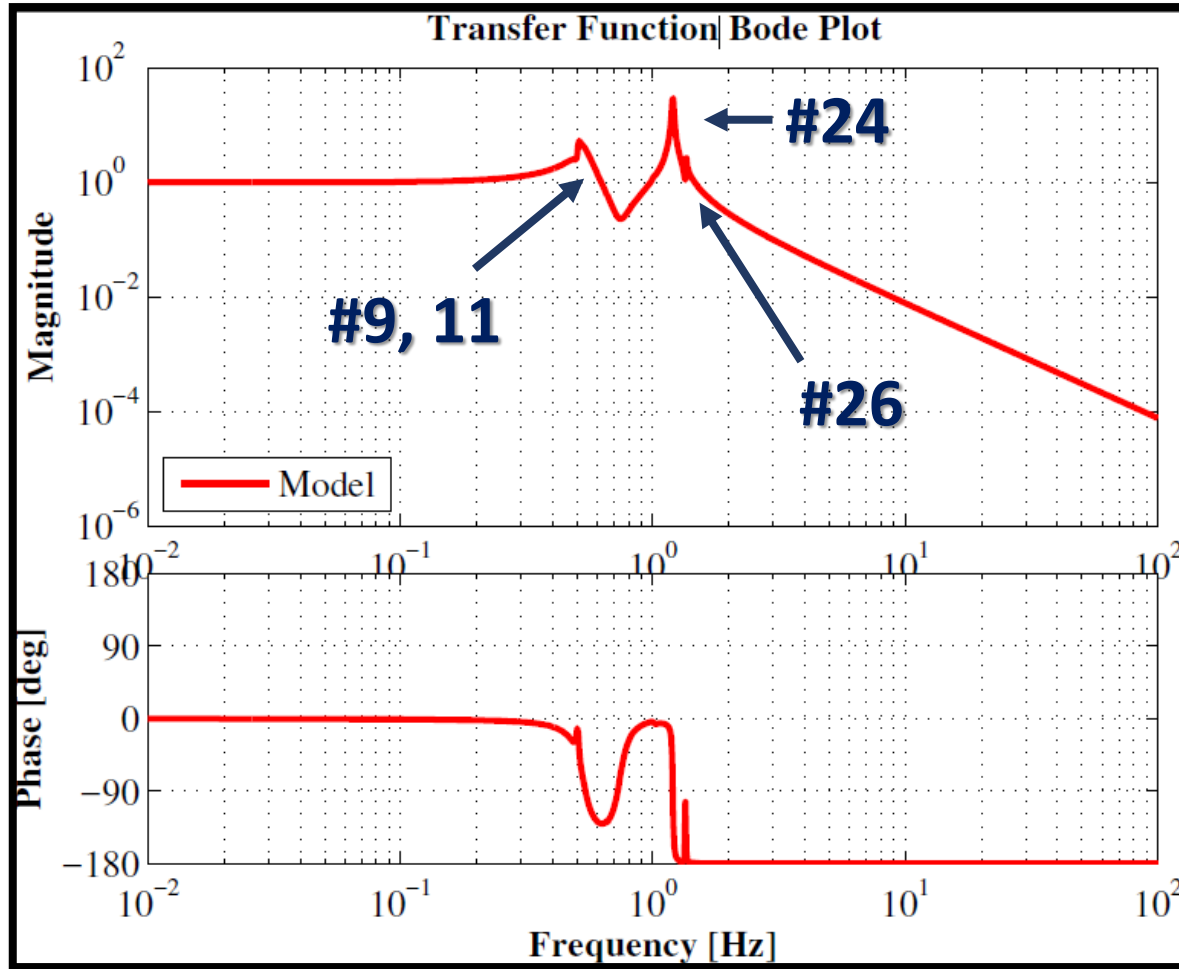

Force Transfer Function

OSEM_VIM / actVIM

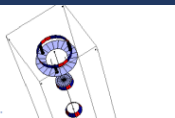
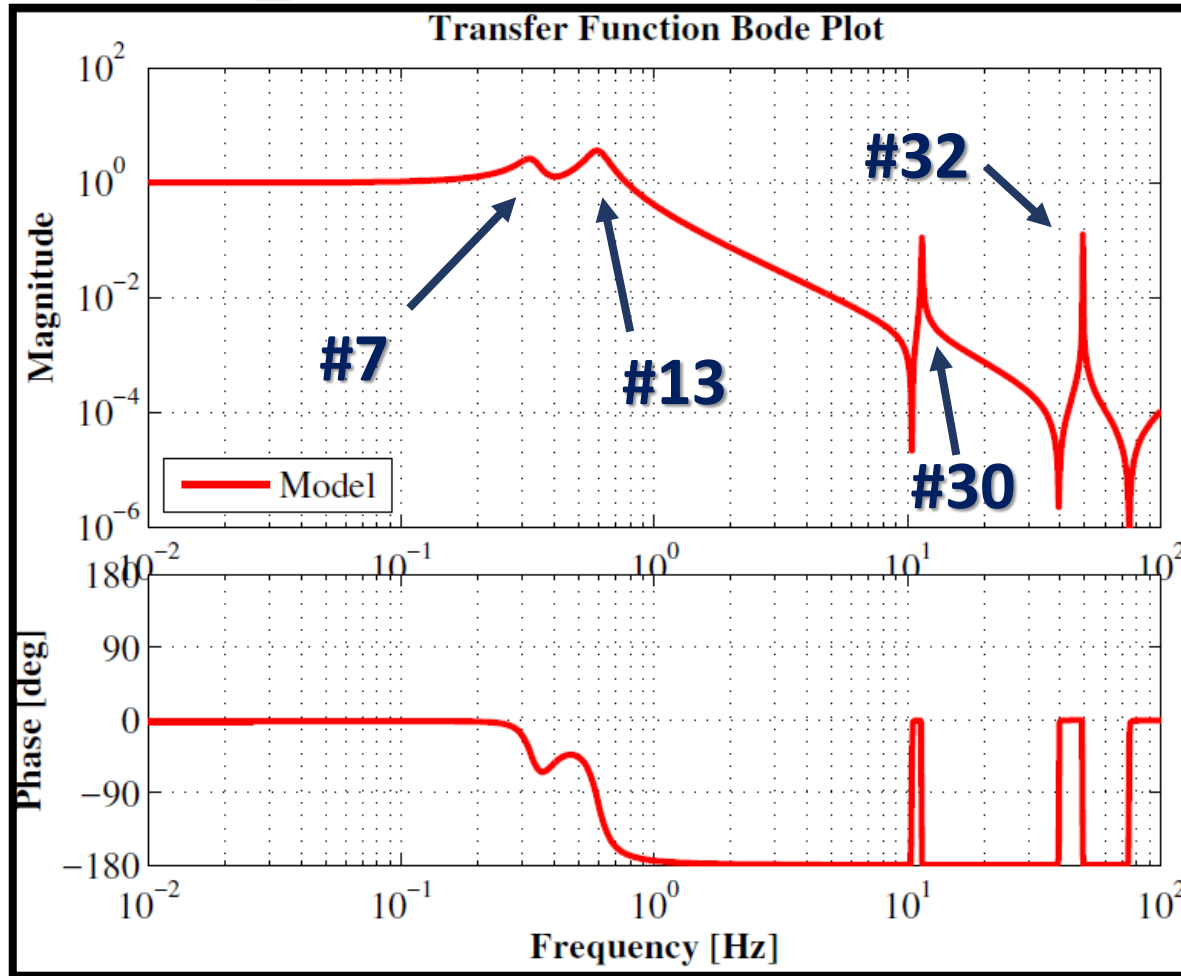
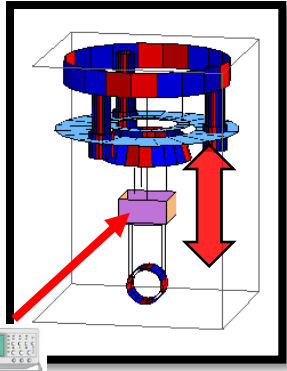

Force Transfer Function

OSEM_RIM / actRIM

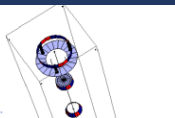
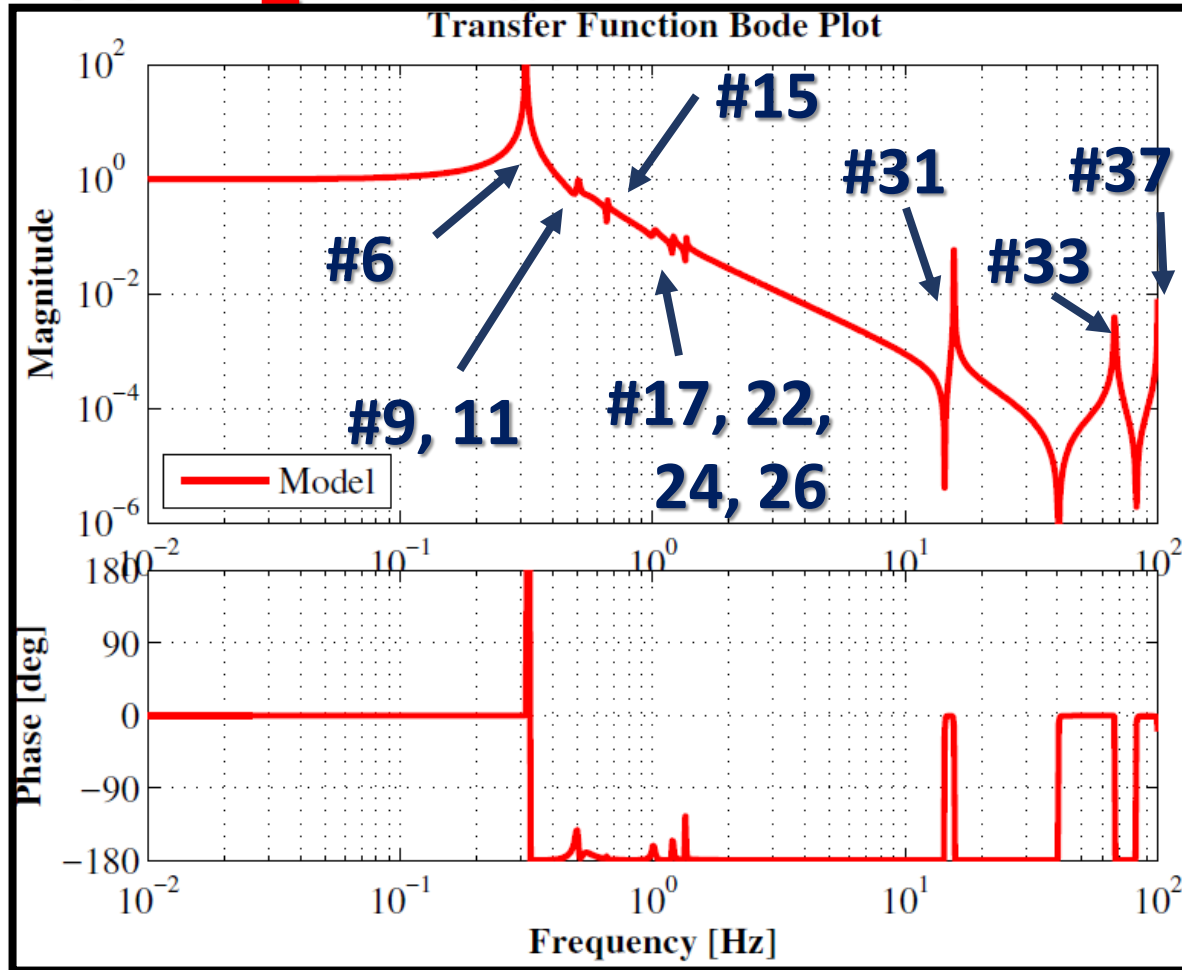
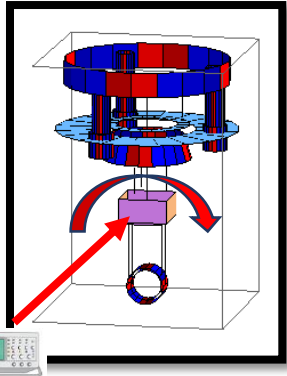

Force Transfer Function

OSEM_PIM / actPIM

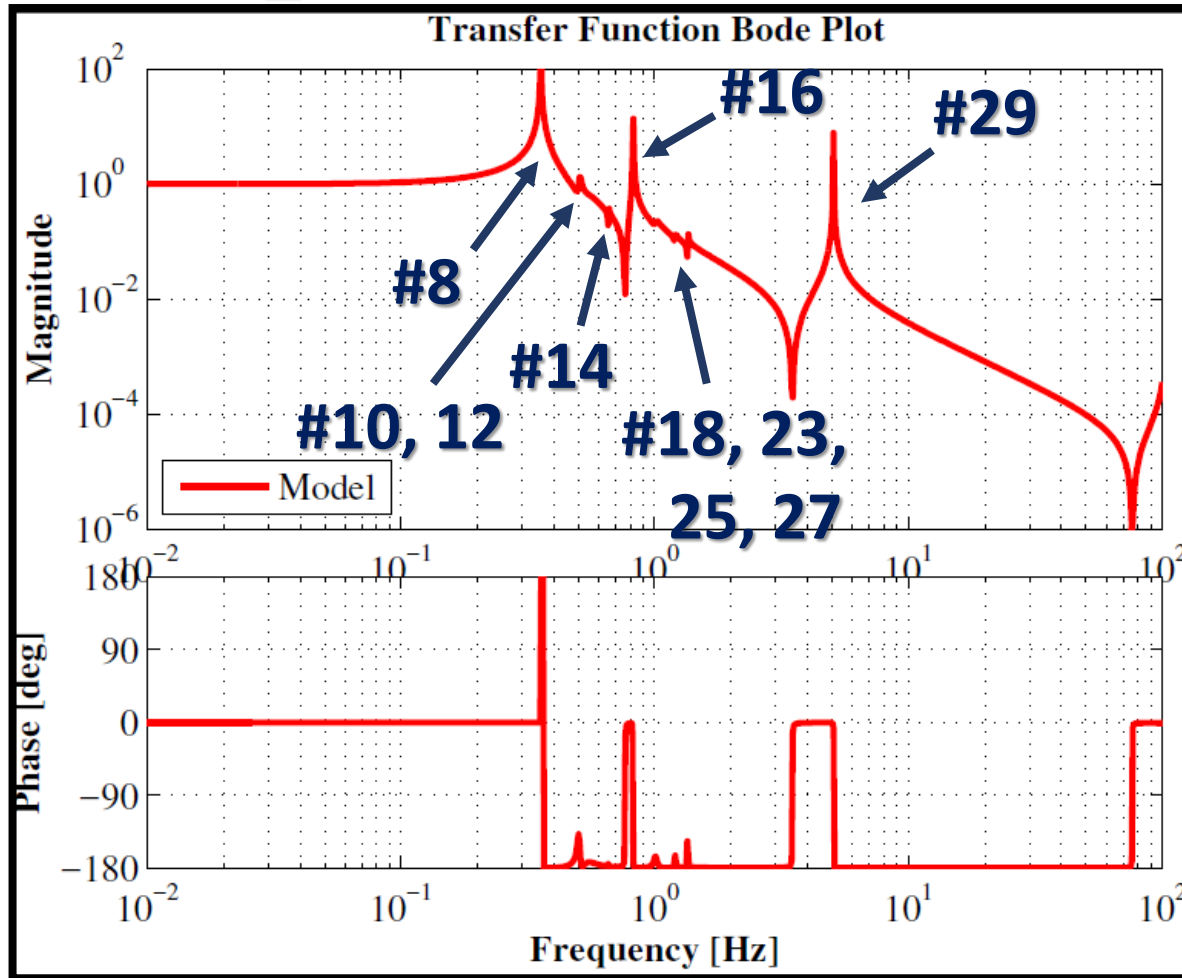
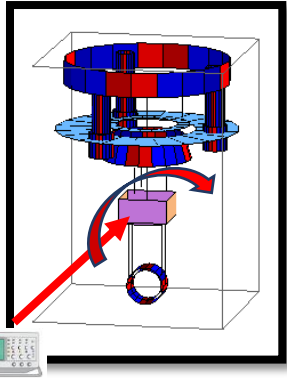

Force Transfer Function

OSEM_YIM / actYIM

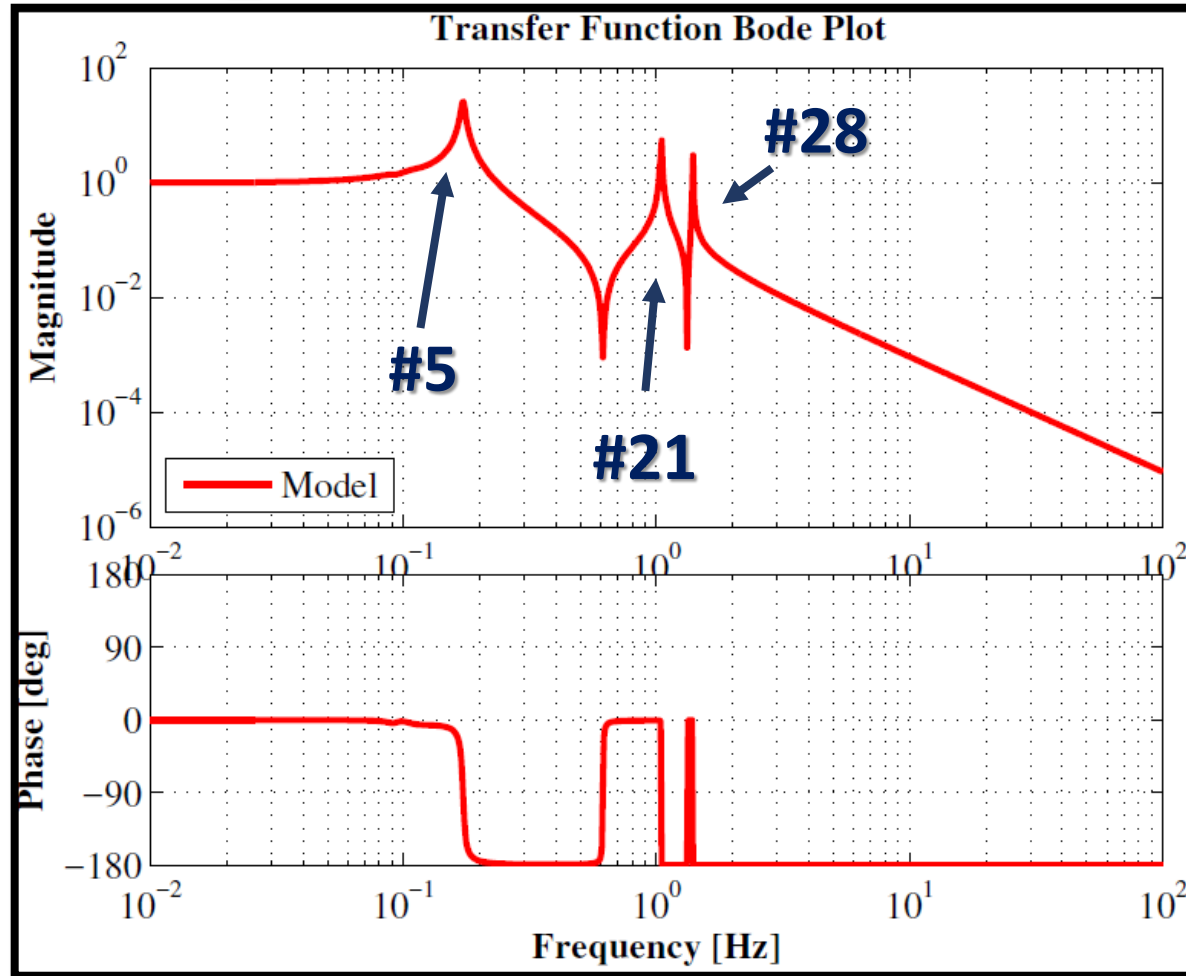
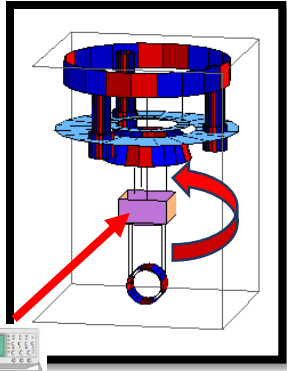

Force Transfer Function

OSEM_LTM / actLTM

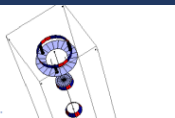
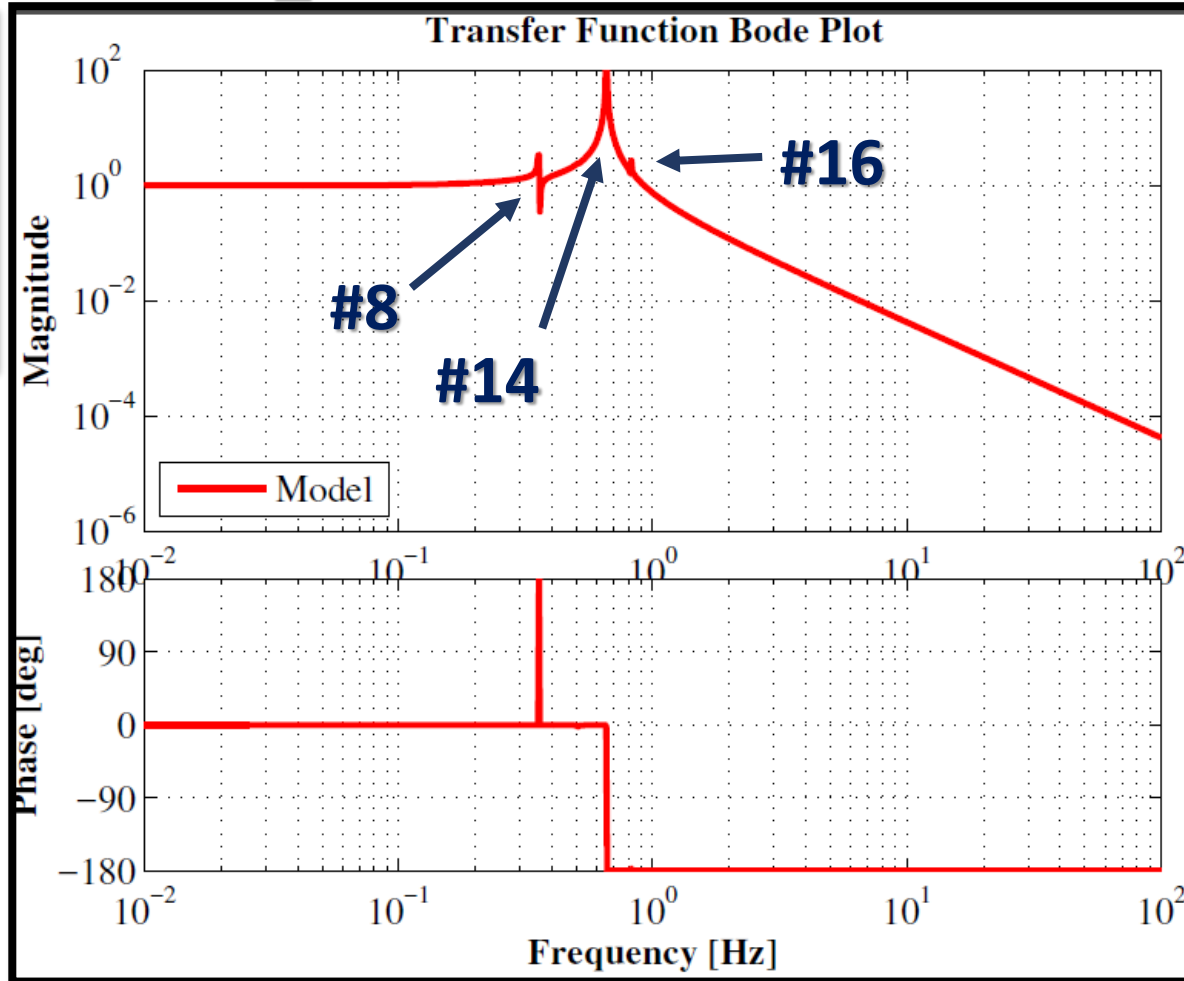
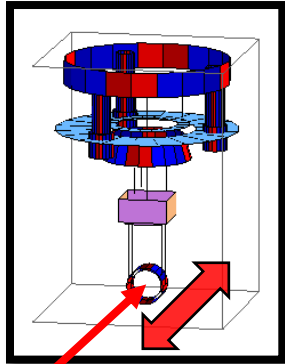

Force Transfer Function

OSEM_PTMM / actPTM

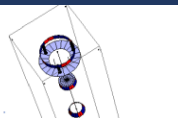
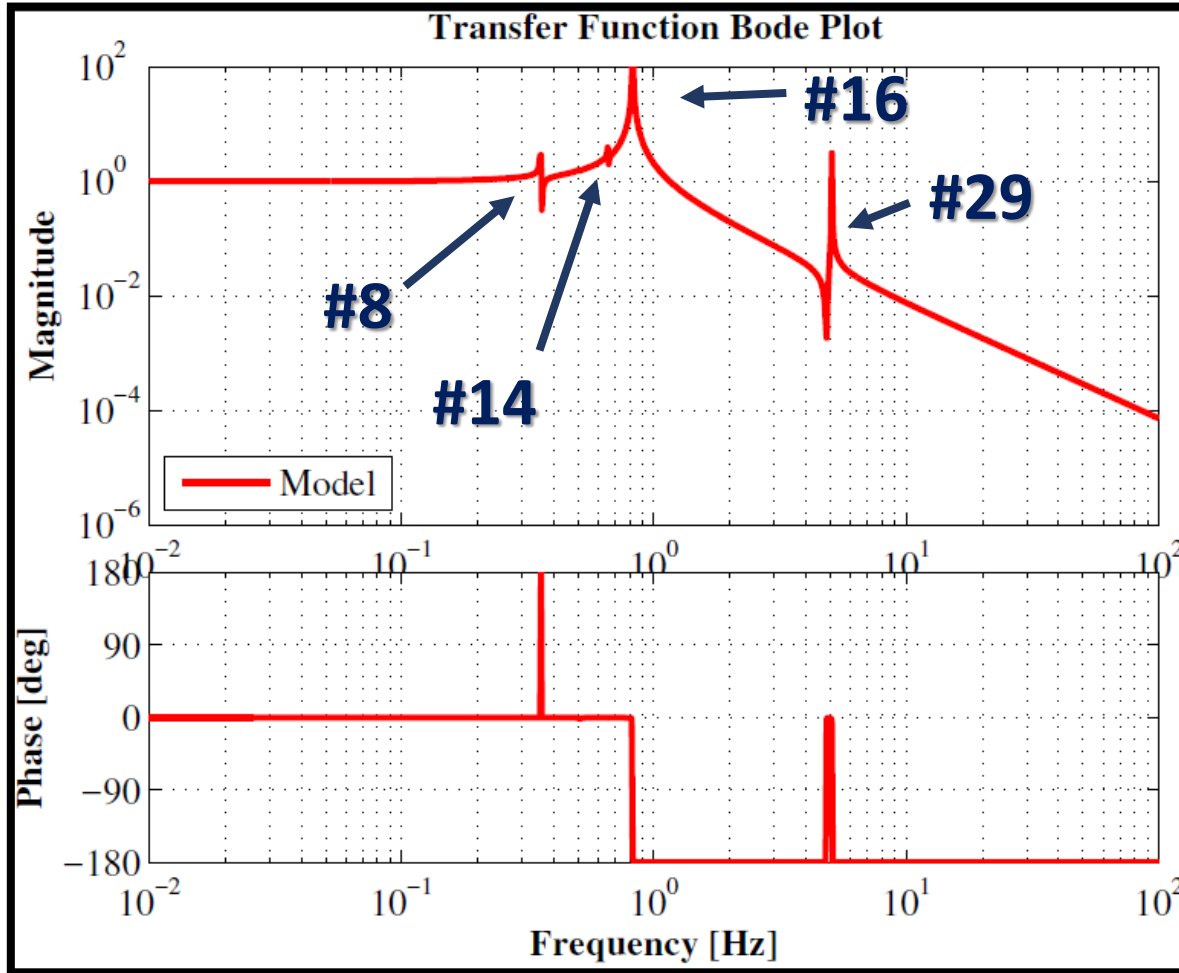
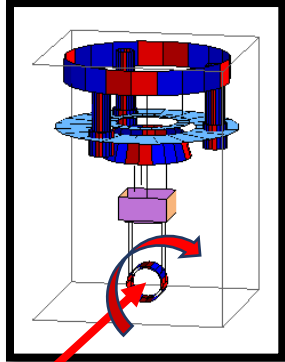

Force Transfer Function

OSEM_YTM / actYTM

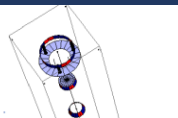
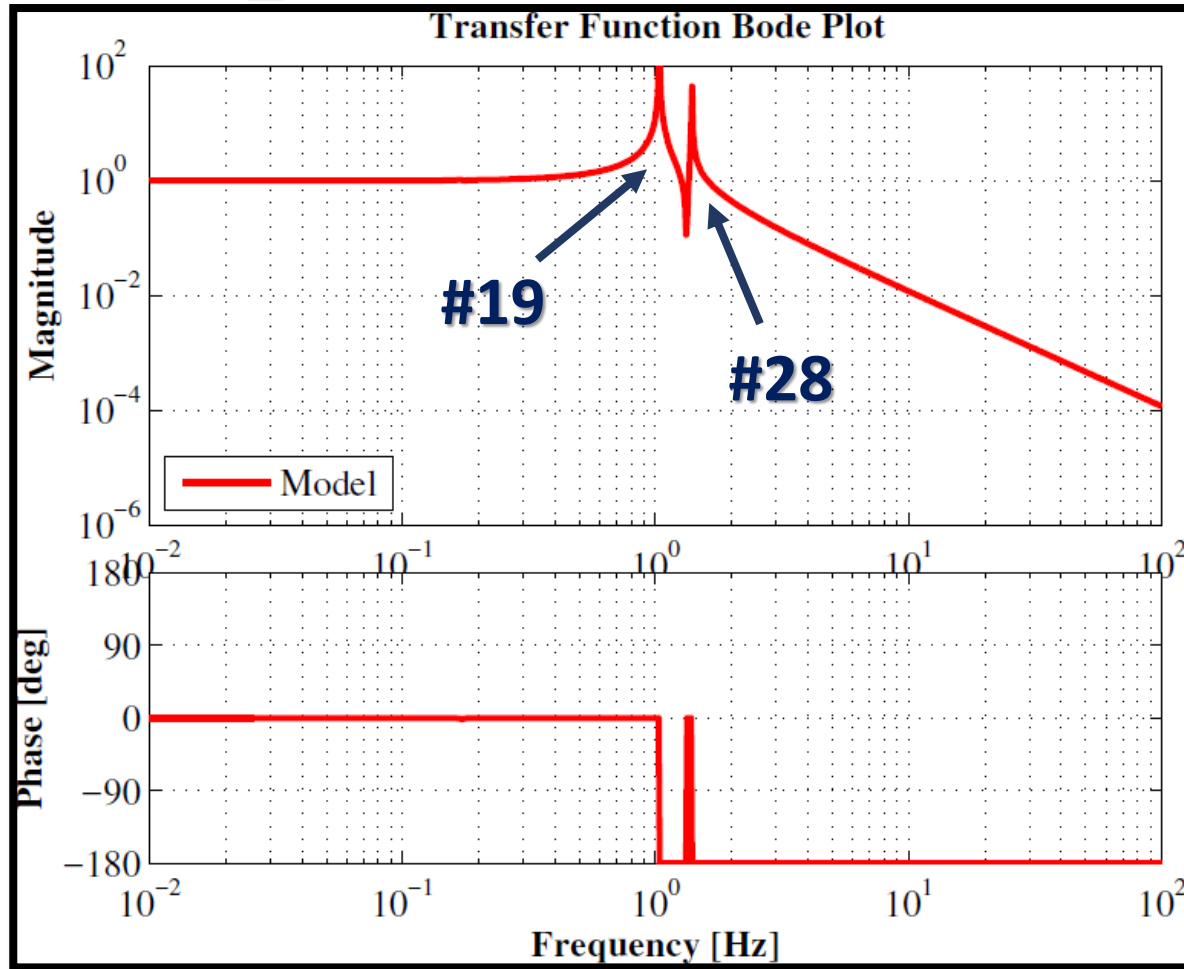
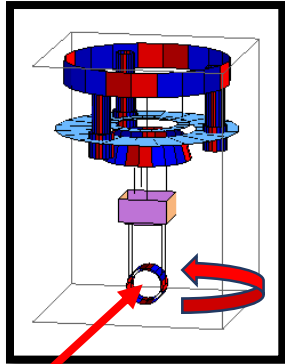

Force Transfer Function

OpLev_PTМ / actPTM

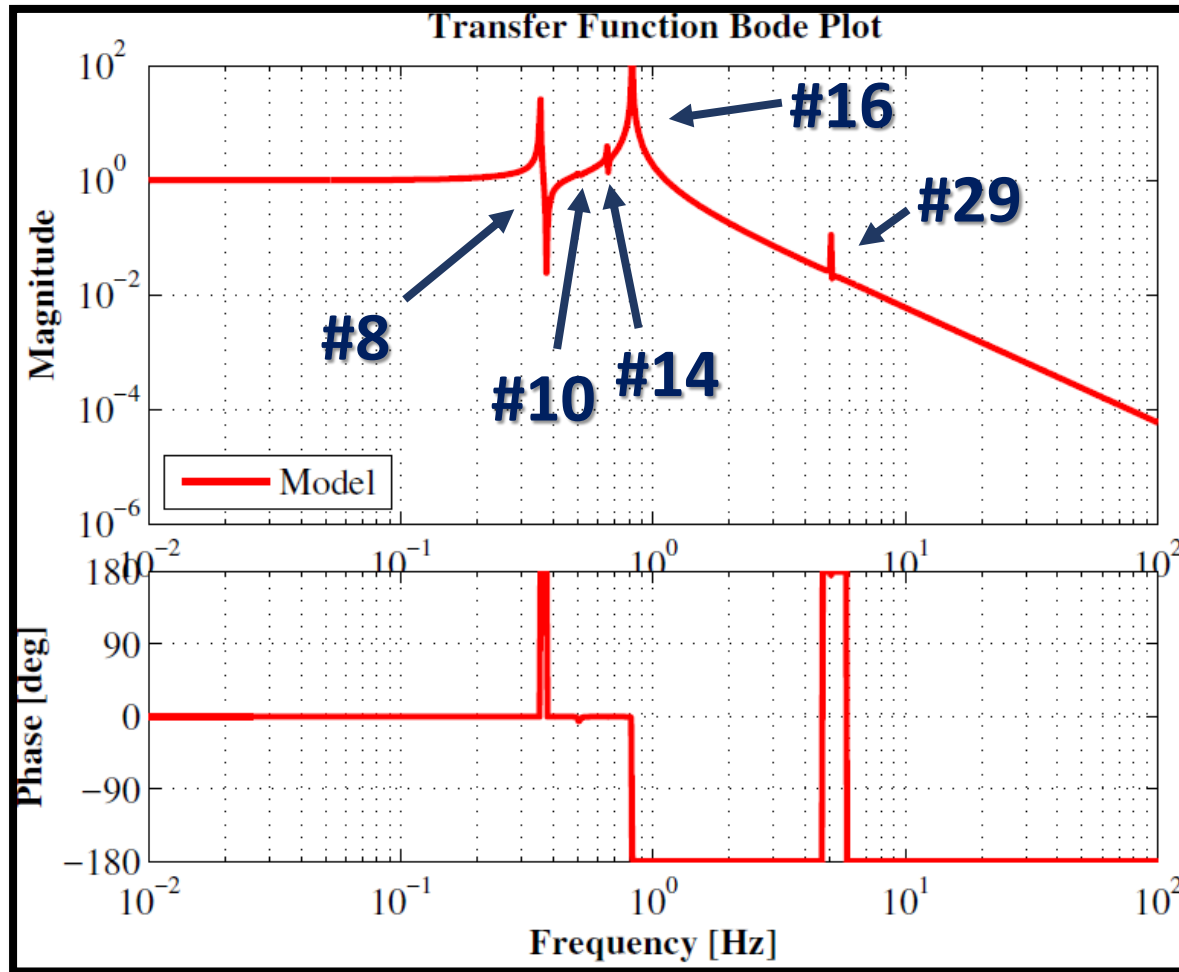
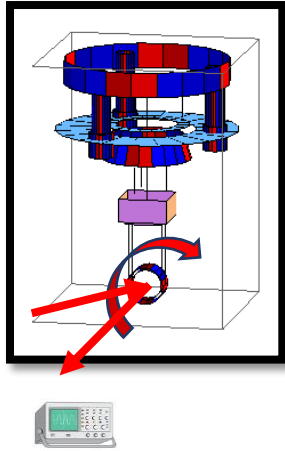

Force Transfer Function

OpLev_YTM / actYTM

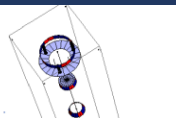
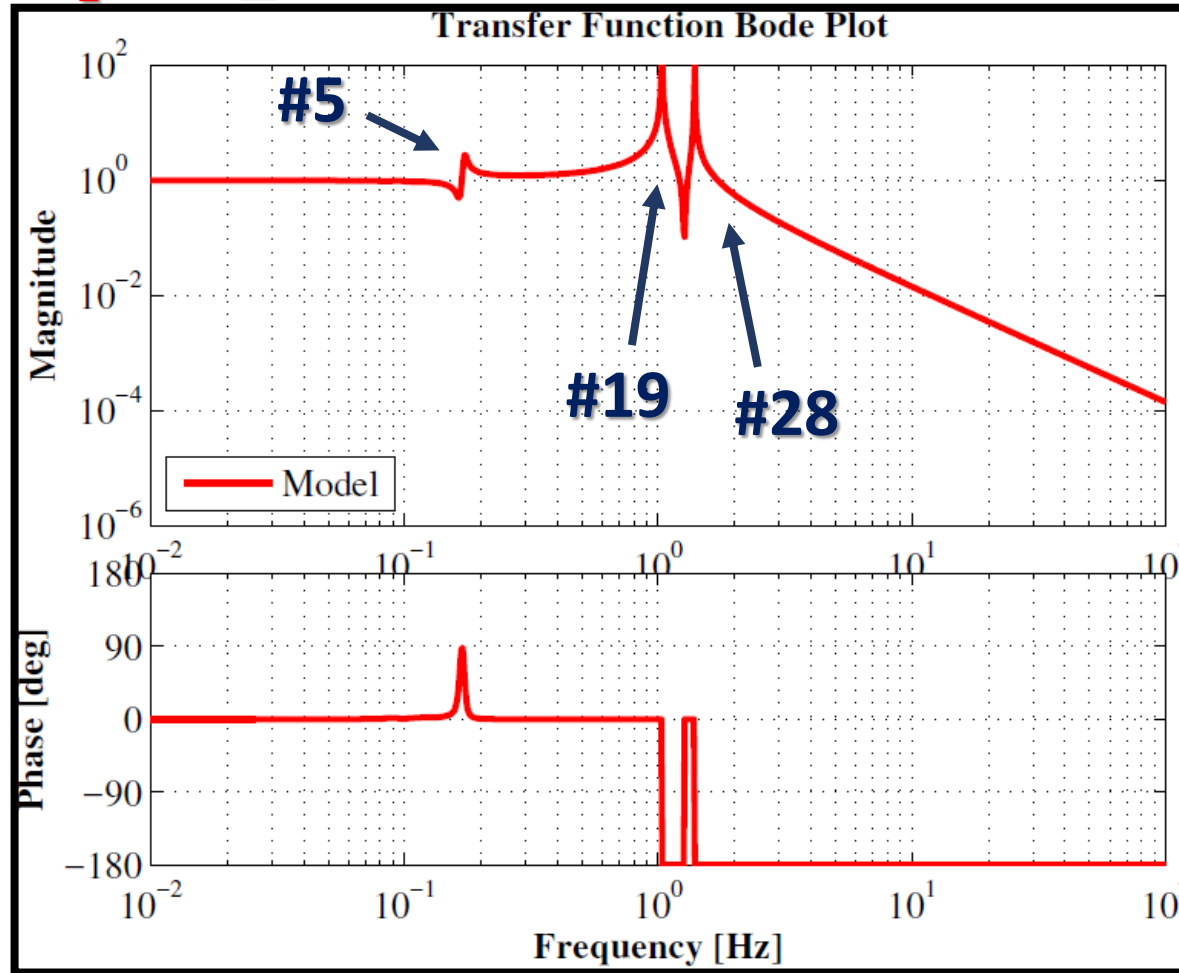
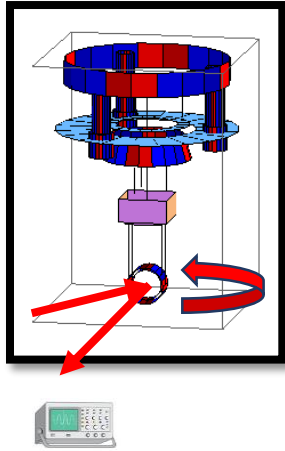

Force Transfer Function

OpLev_PTM / actPIM

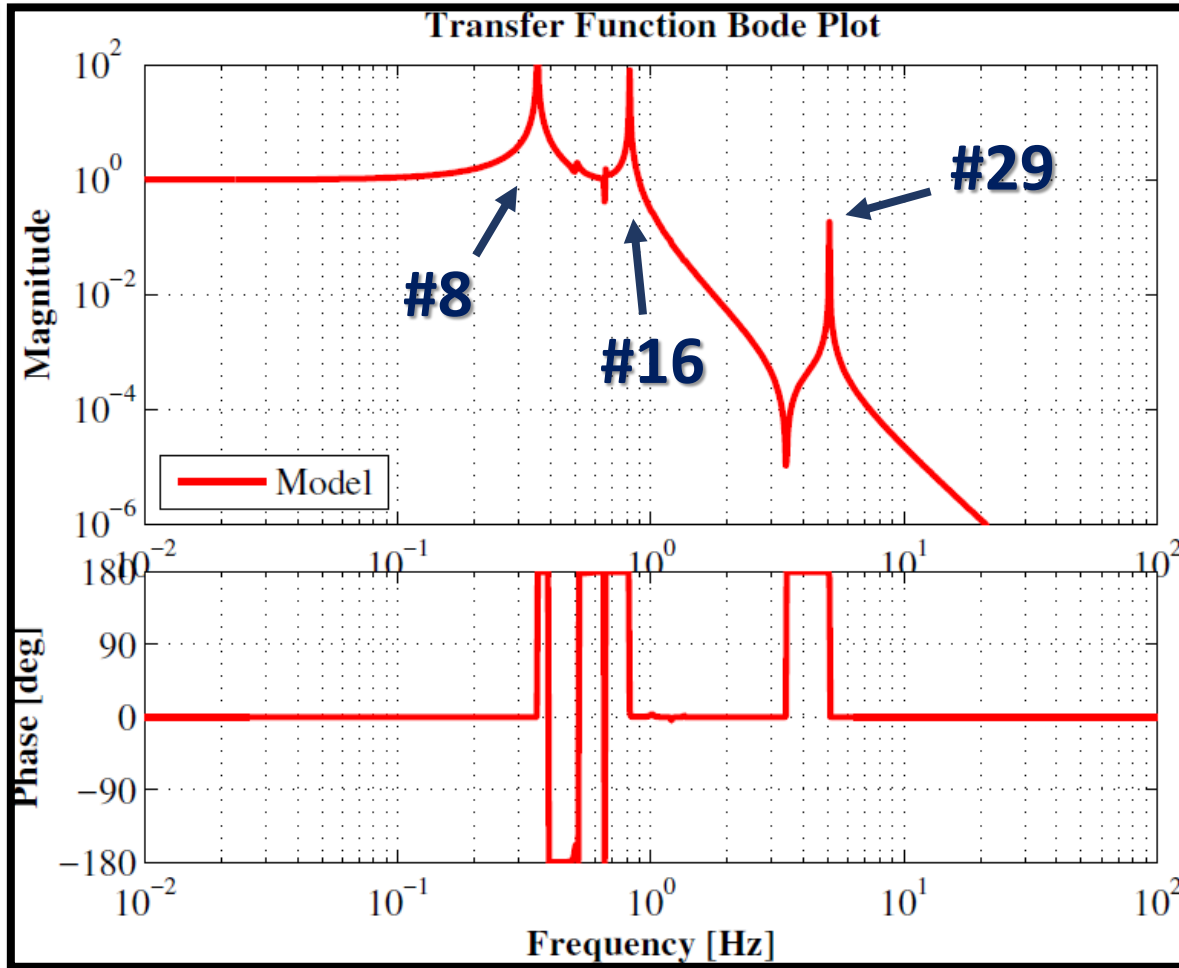
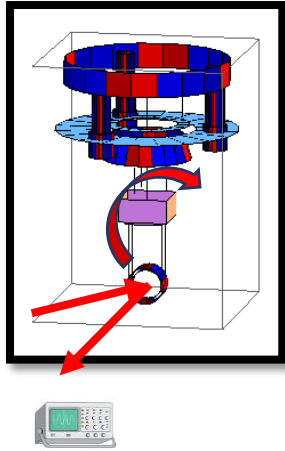

Force Transfer Function

OpLev_YTM / actYIM

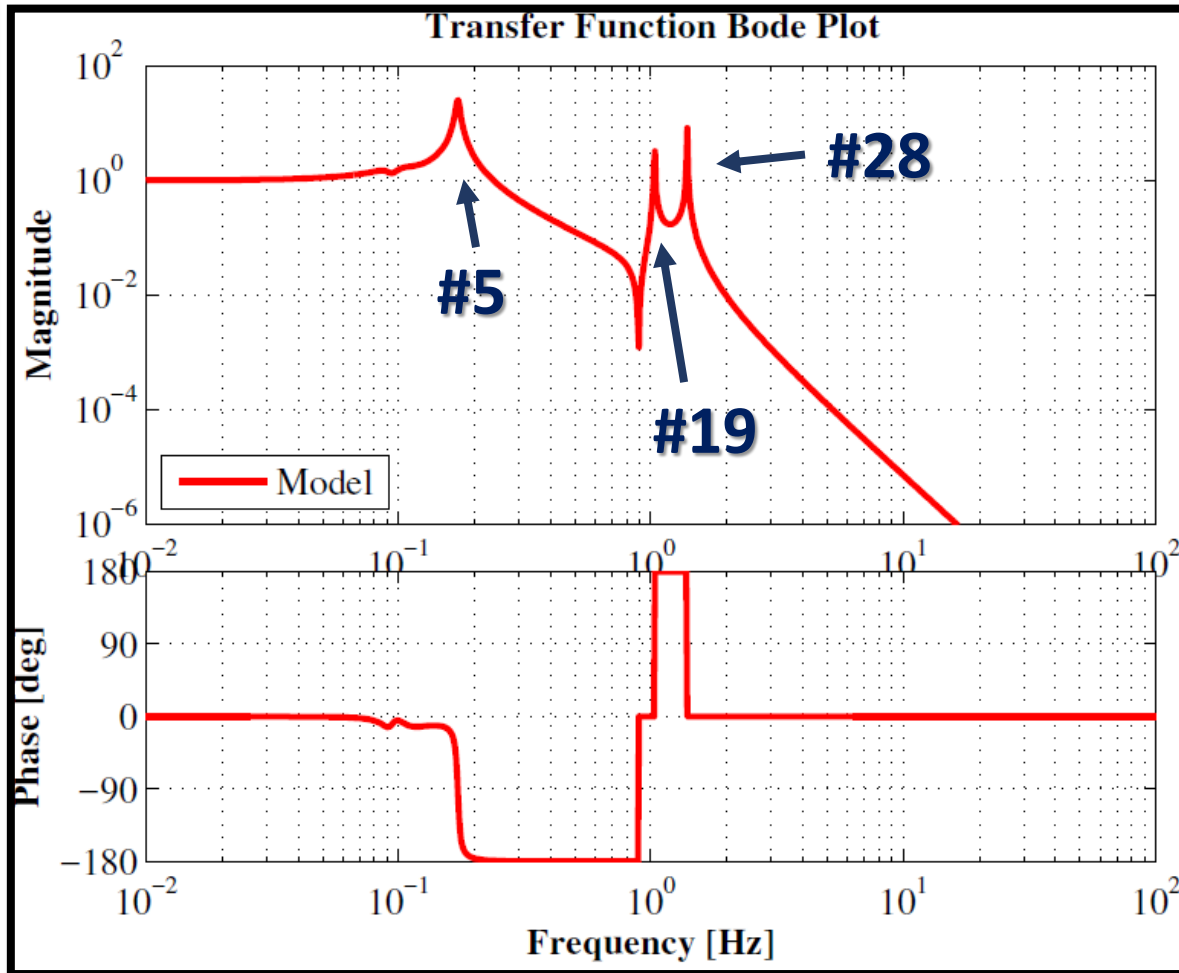
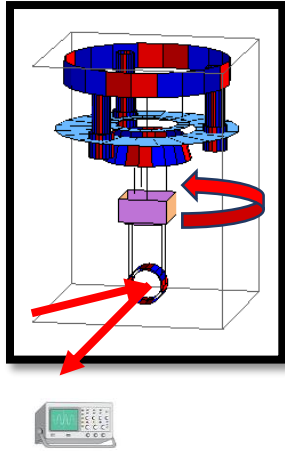

Force Transfer Function

OpLev_PTM / actLF1

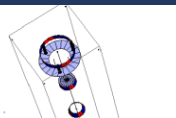
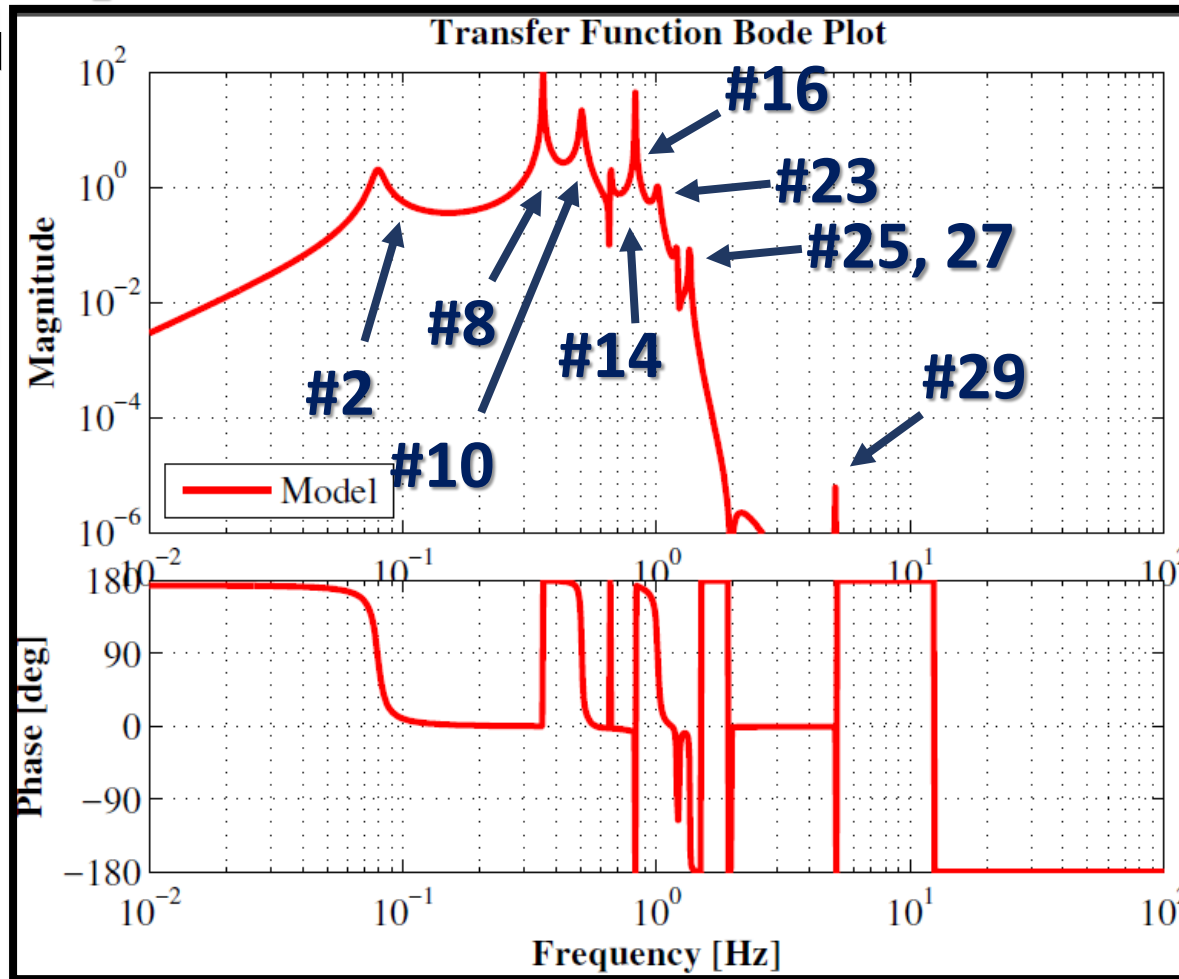
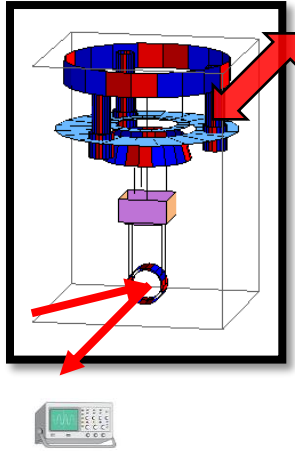

Force Transfer Function

OpLev_YTM / actYF1

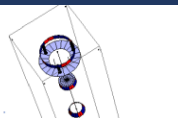
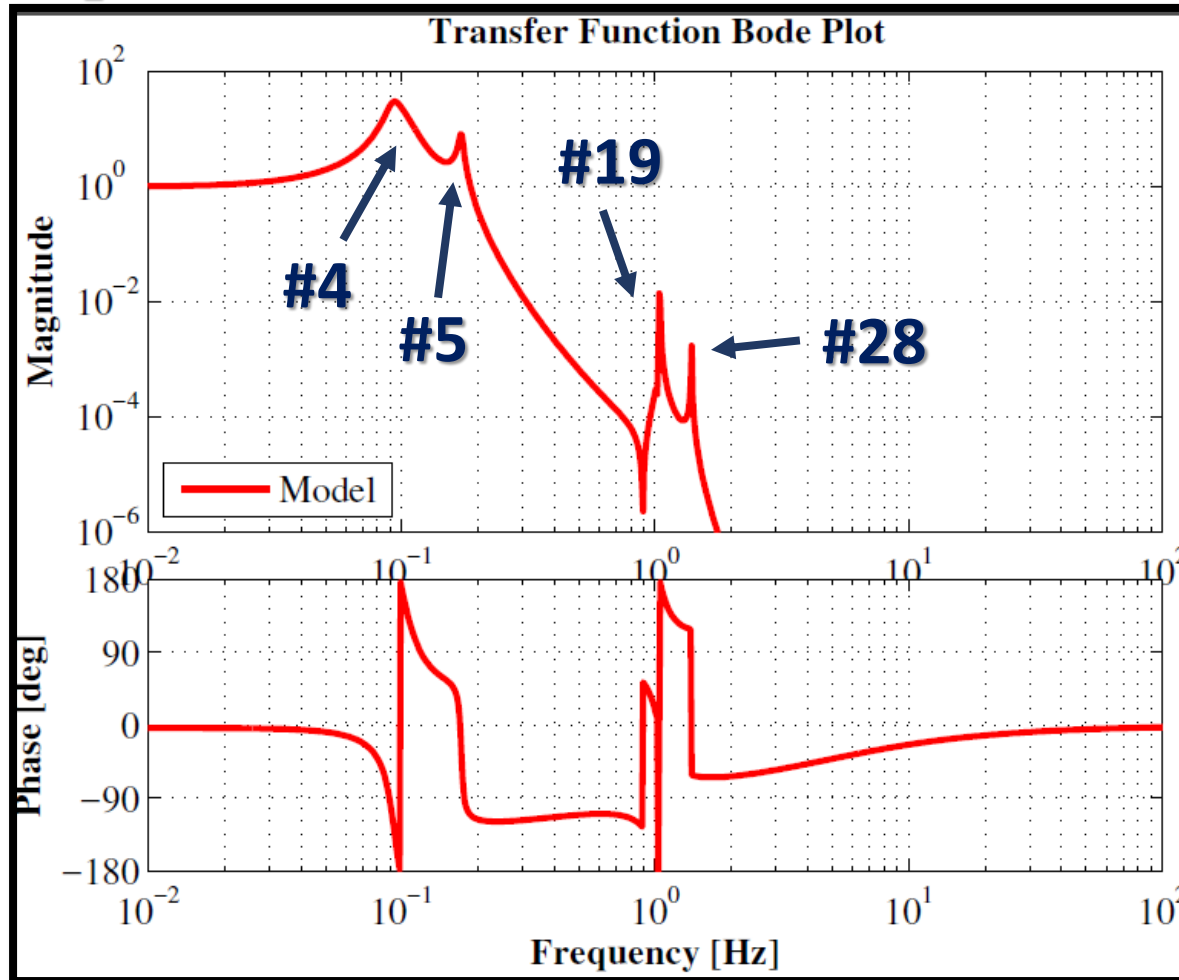
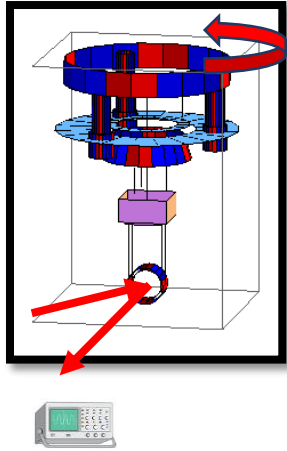

Force Transfer Function

GlobalSensor_LTM / actLF1

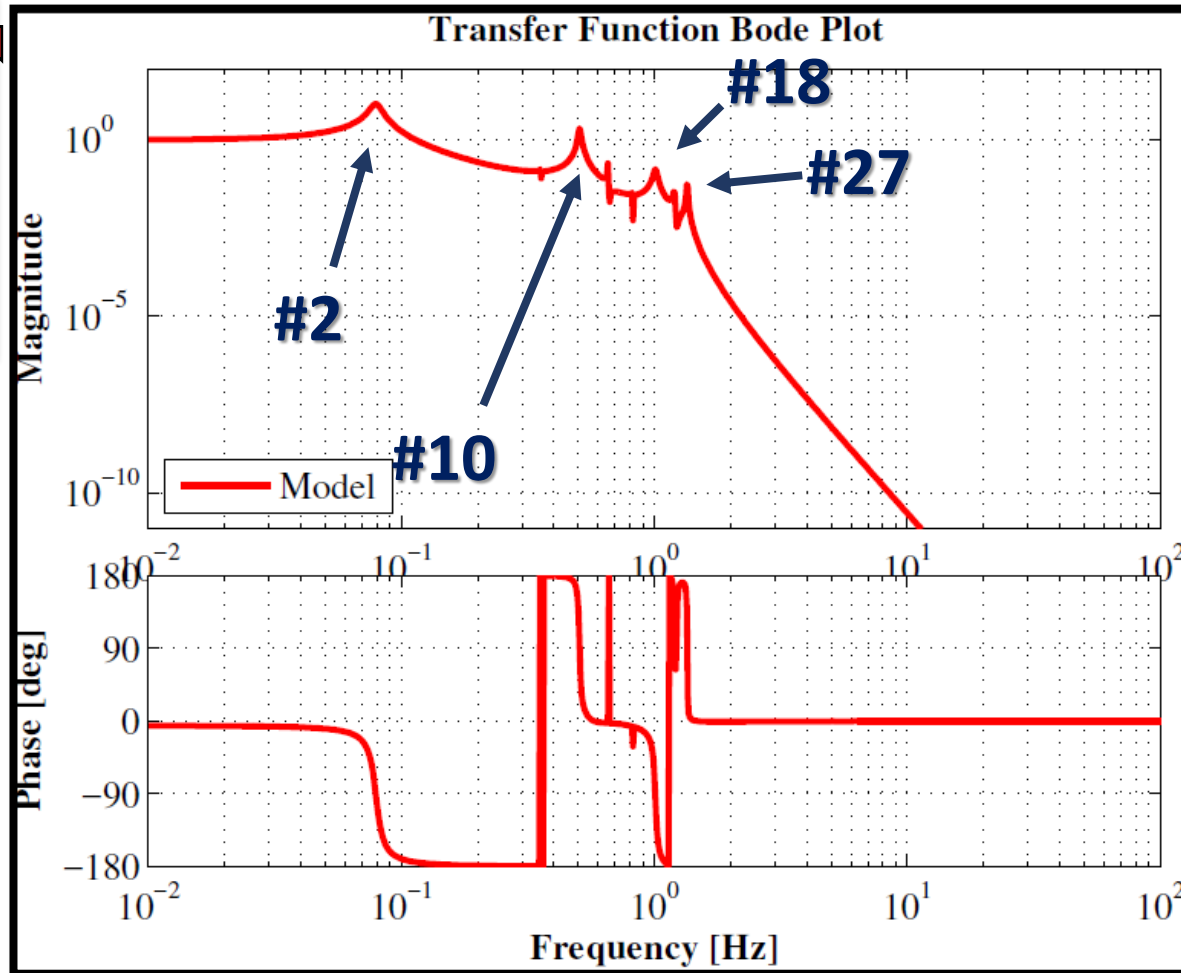
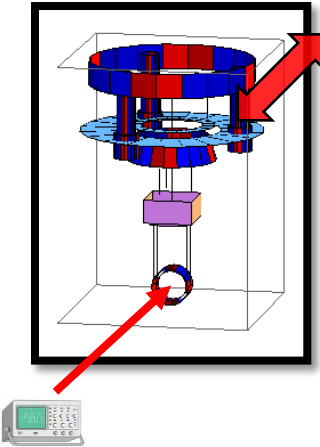

Spectra

without control

using 90 percentile seismic noise

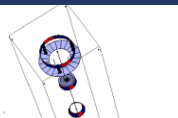



2 Seismic noise level at the Kamioka site

The seismic displacement and velocity we used is shown in Fig.2 and ??[2]. This is the one called high-noise model. The seismic displacement in Kamioka is below this level for 90 % of time.

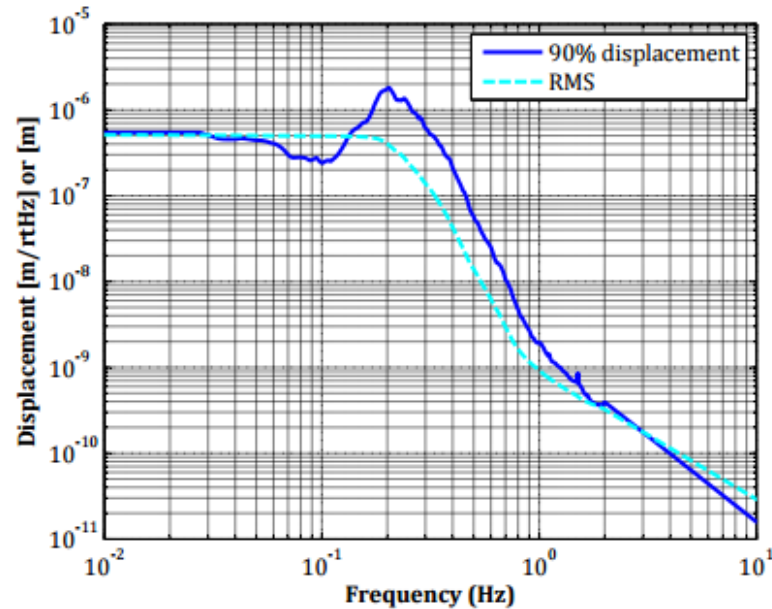

Figure 1: The high-level seismic displacement in Kamioka.

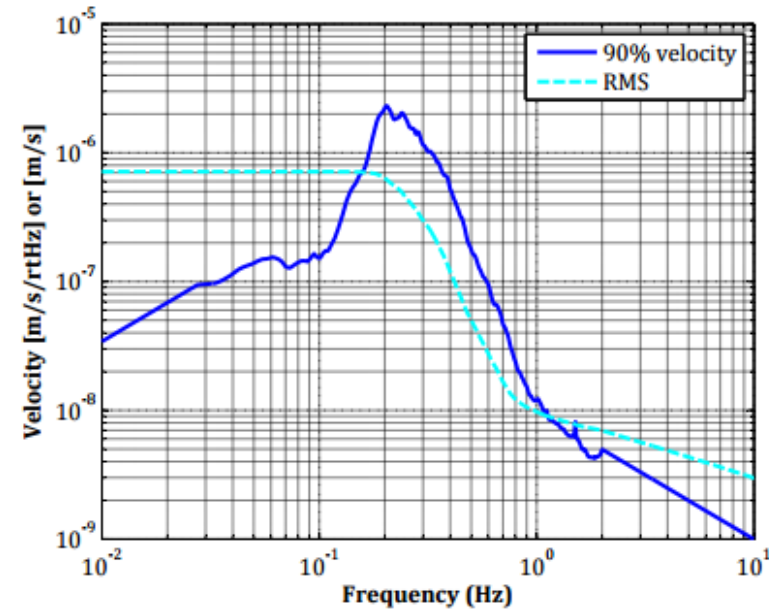
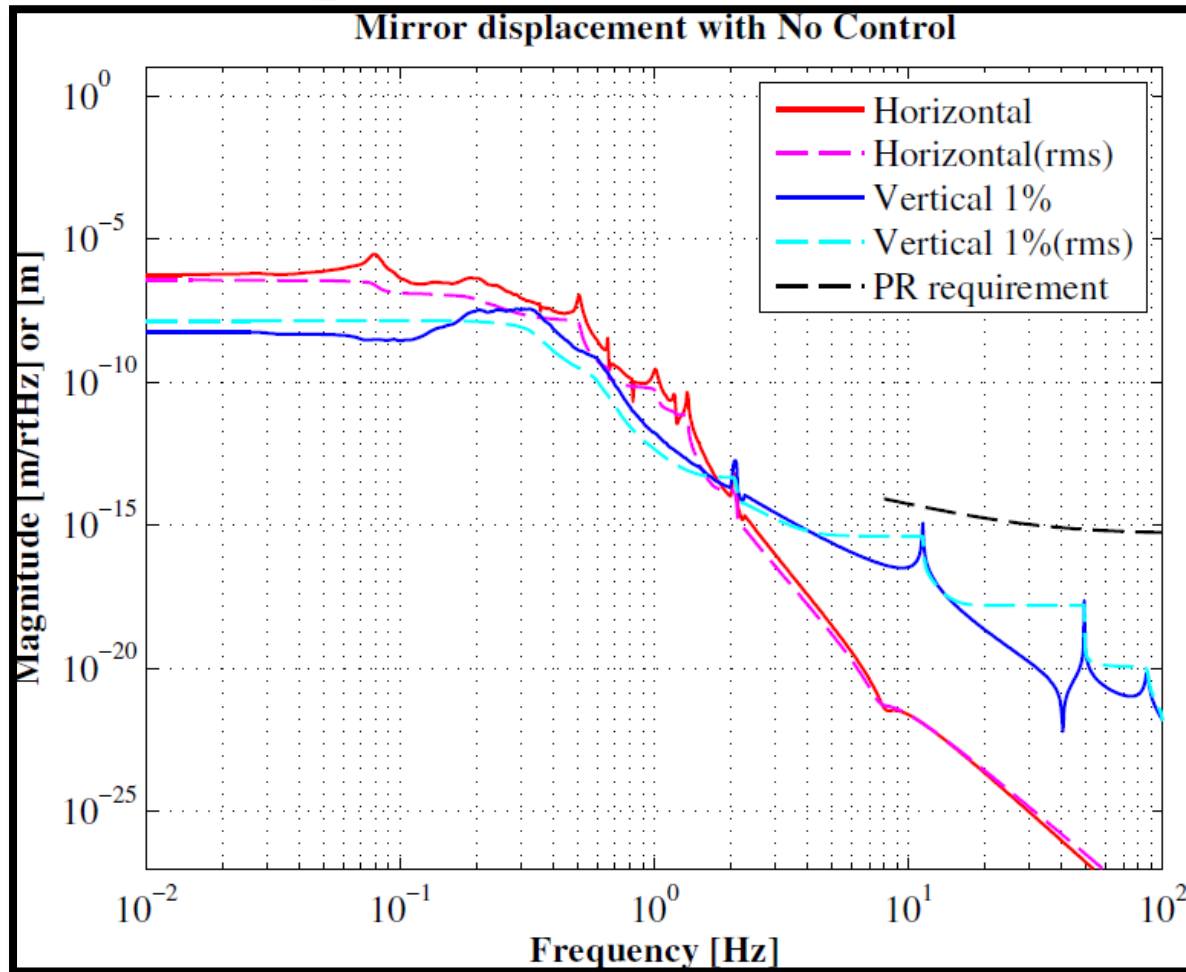

Figure 2: The high-level seismic velocity in Kamioka.

Spectra without ctrl

TM displacement : H and V 1%



TM displacement : H + V 1%

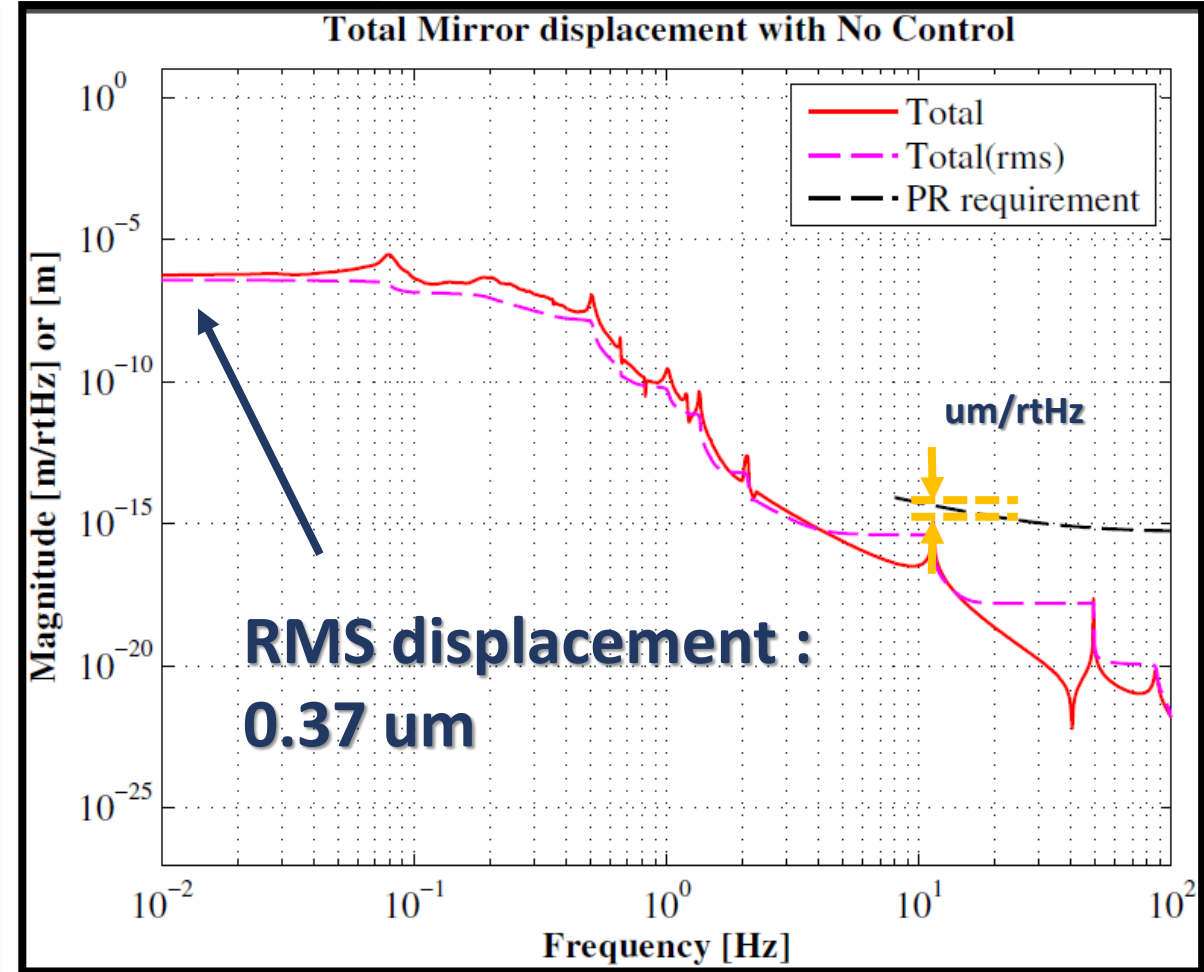

Spectra without ctrl

TM velocity : H and V 1%

Mirror velocity with No Control

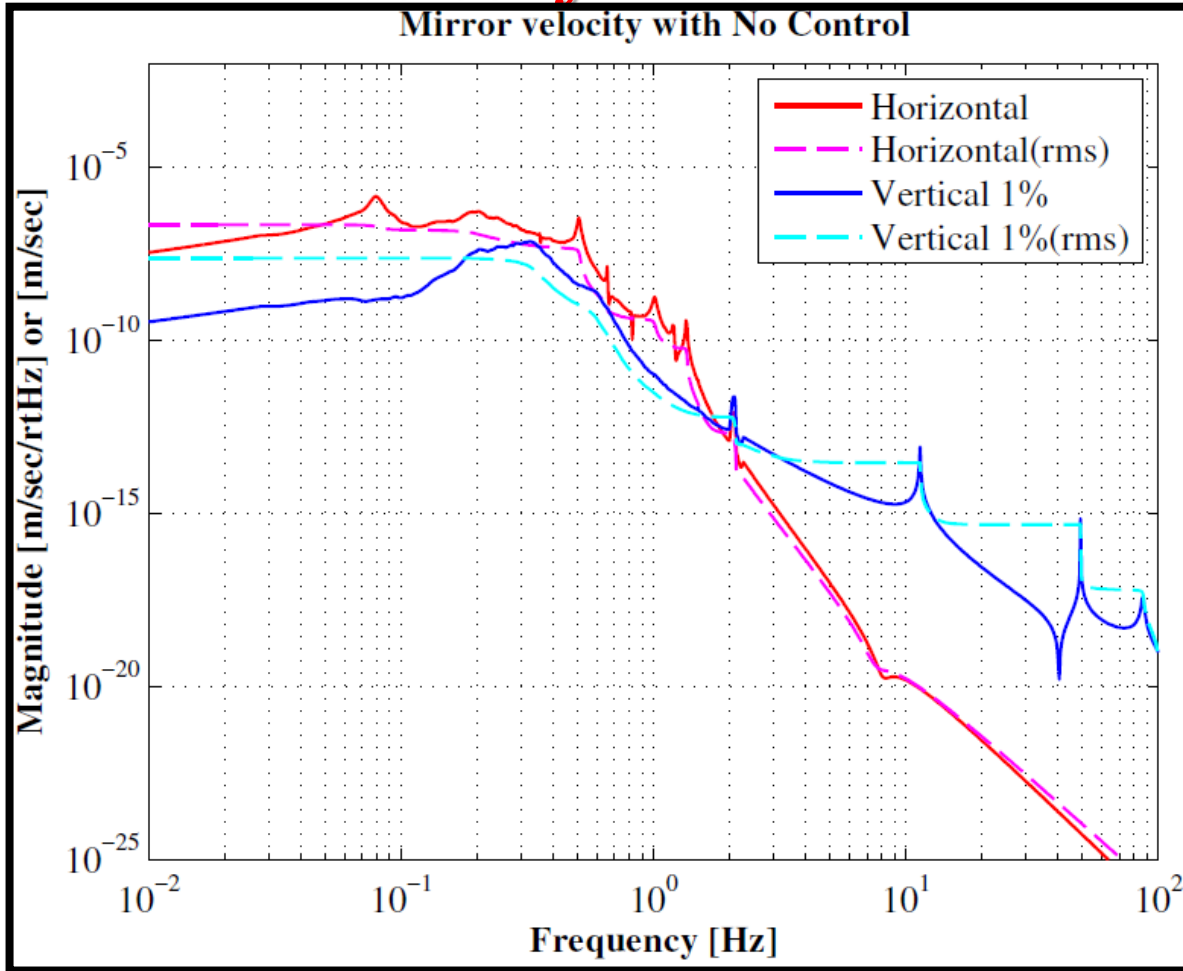

TM velocity : H + V 1%

Total Mirror velocity with No Control

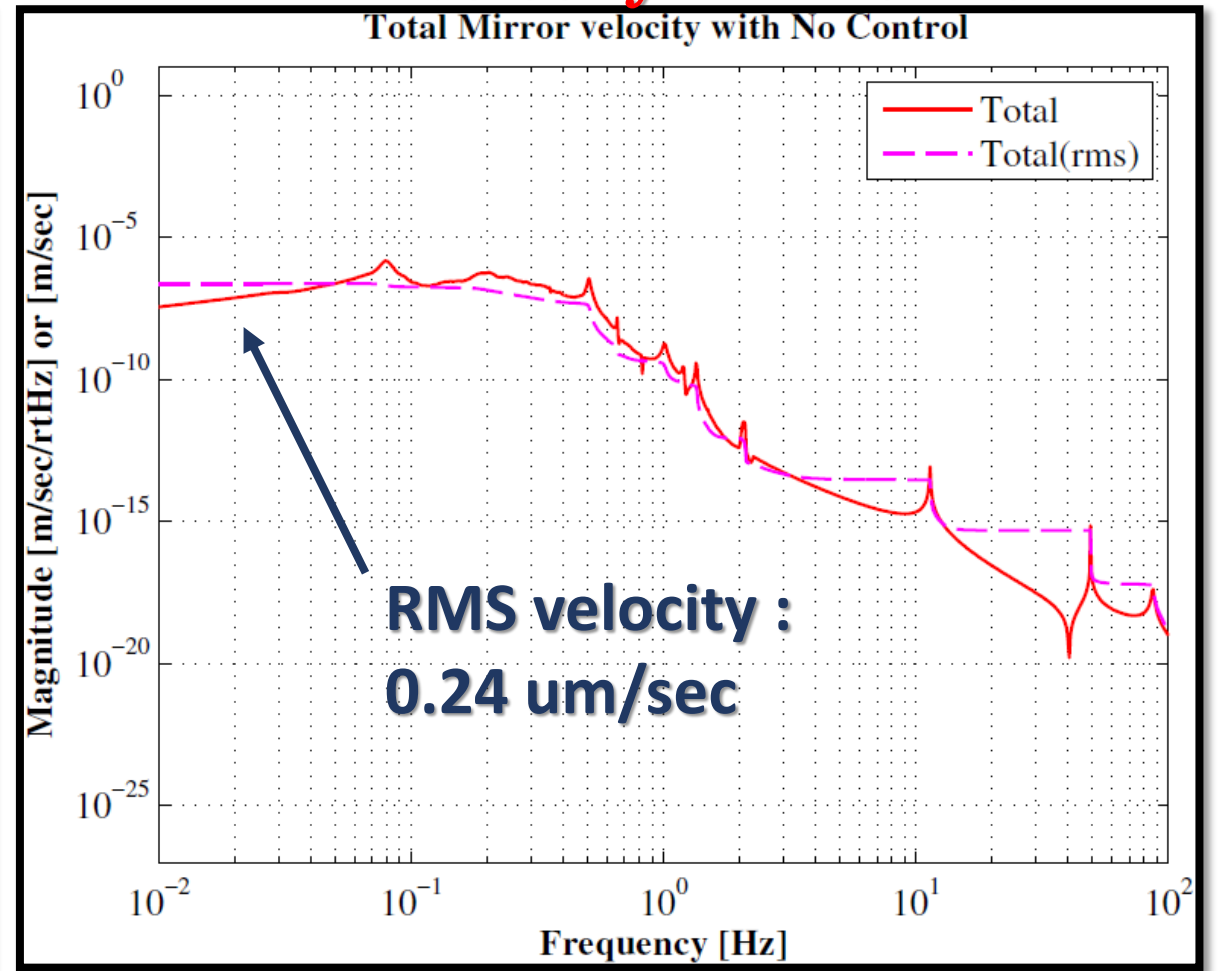

Spectra without ctrl

TM Pitch Angular fluctuation

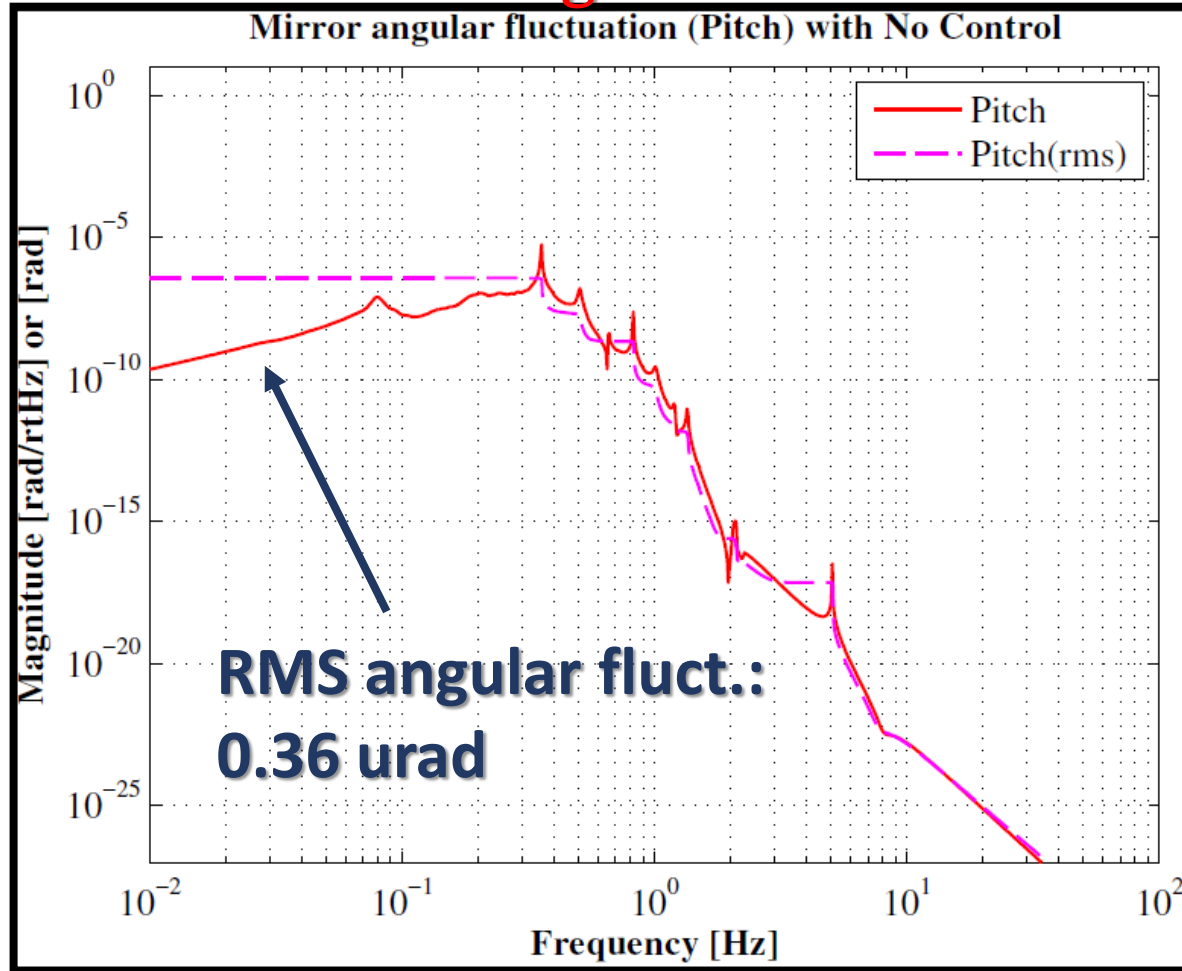

TM **Pitch** fluctuation
excited by **Longitudinal** GND motion

Spectra without ctrl

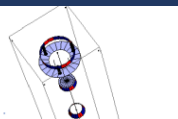

Control Simulation Results

Filter shape

OLTF

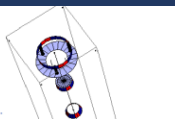

CLTF

Q factor in damping control

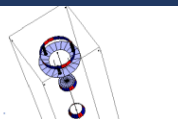

Impulse response