

# iKAGRA初期アライメント手順 Initial Alignment Procedure for iKAGRA

Yuta Michimura

Department of Physics, University of Tokyo

# First of All

- Commissioning?
  - suspension, oplevs, cameras, digital, electronics, output optics, initial alignment, lock, stable operation, noise budgeting .....
- I will focus on iKAGRA initial alignment procedure discussion
  - 3 km Michelson after IMMT
- I strongly recommend you to download JGW-T1604823
- **Important message:**  
**Commissioning team**  
**wants your contribution!**



# Expected Situation on Mar 2

- All the mirrors (PR2, PR3, BS, ETMX, ETMY) installed with actuation from digital system (pico, OSEMs, coils)
- stable >250 mW from IMC in high finesse mode (s-pol)
- both 3km ducts evacuated (φ10cm viewport on each end; for Y arm, IYA+IYC also evacuated)

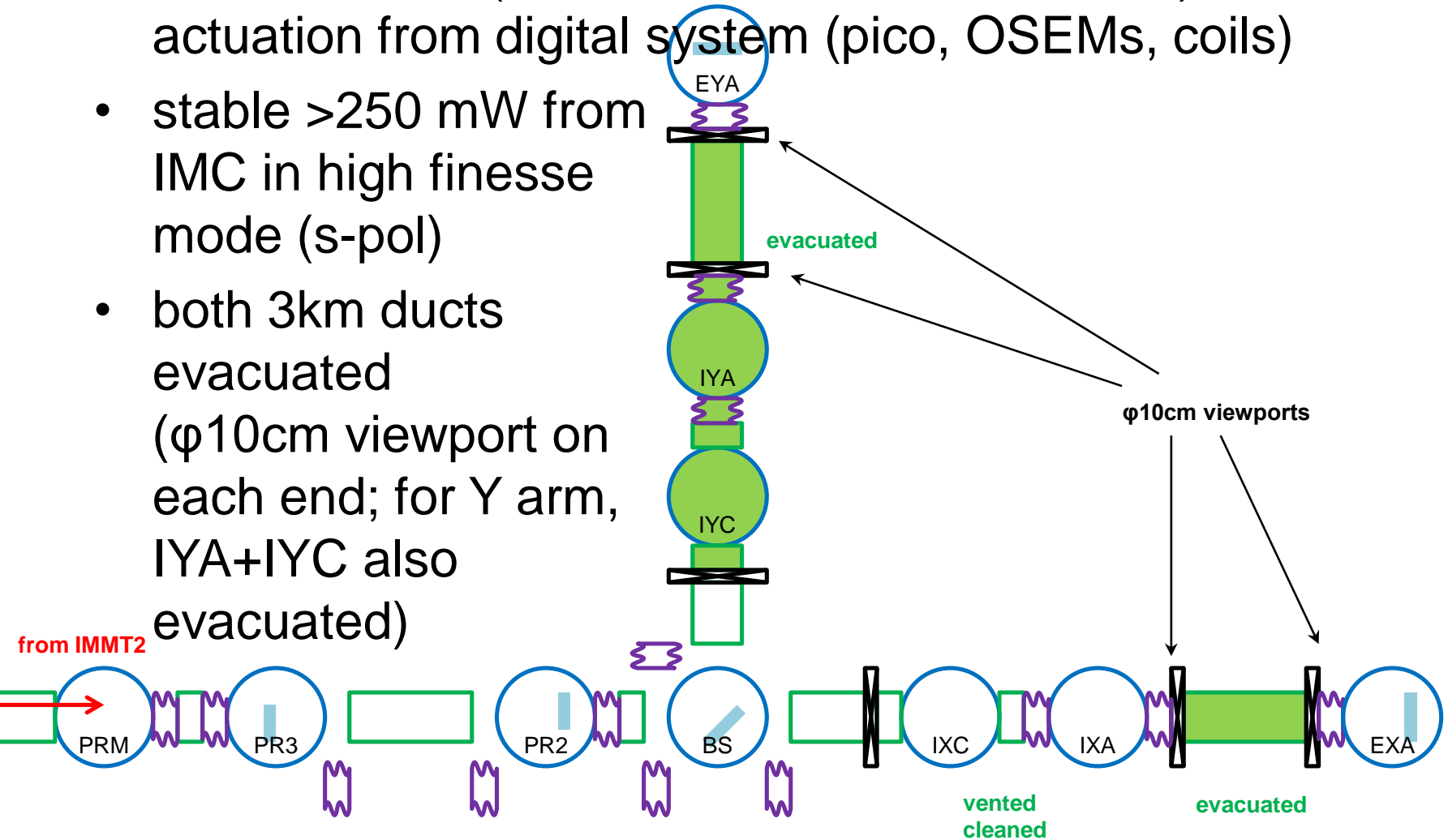

# IMMT2 Alignment (Mar 3)

- Use picomotors on IMMT2 to center the beam on PR2
- PR3, PR2 chambers opened

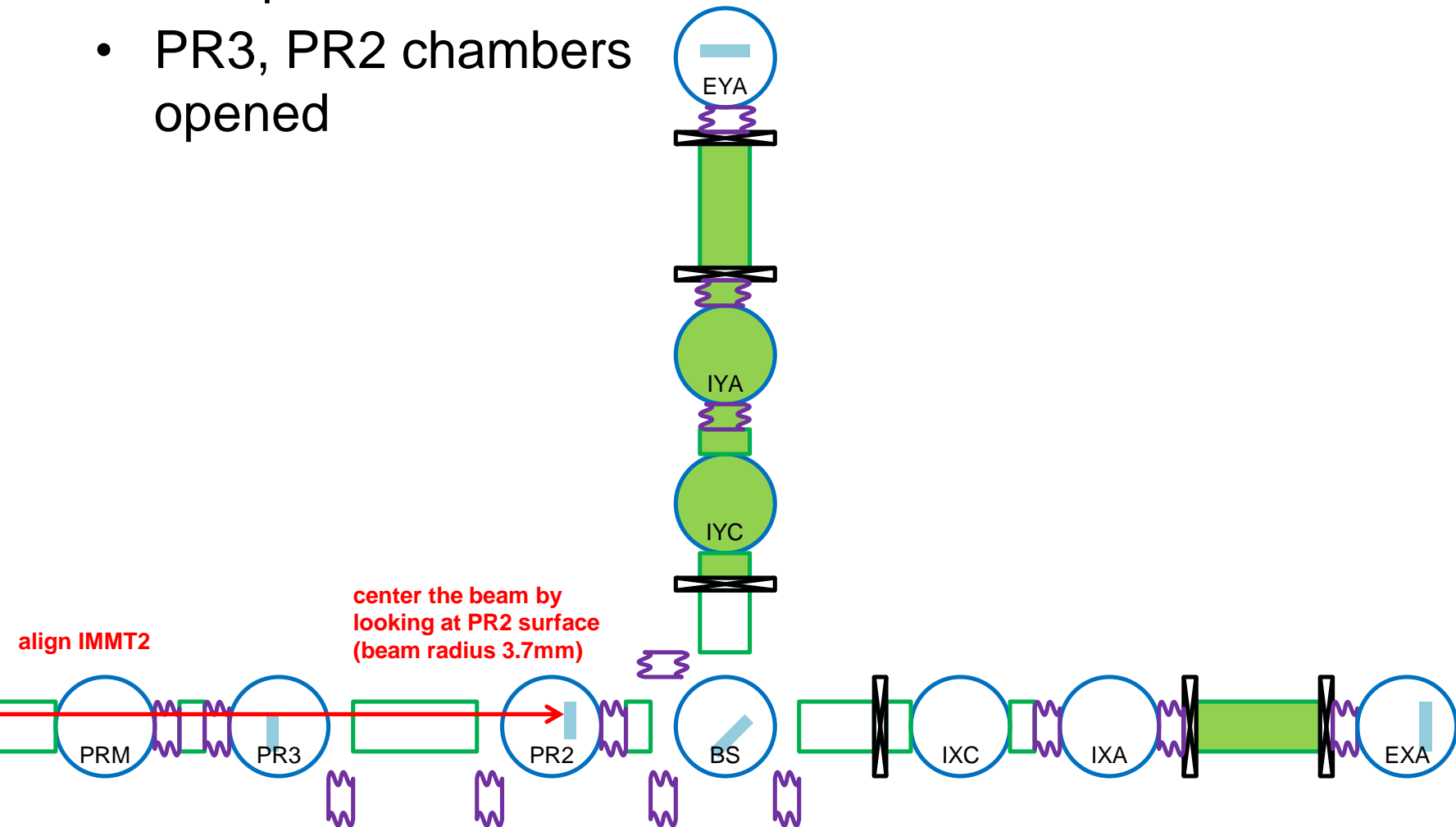

# PR2 Alignment (Mar 3)

- Use picomotors on PR2 to center the beam on PR3
- PR3, PR2 chambers opened

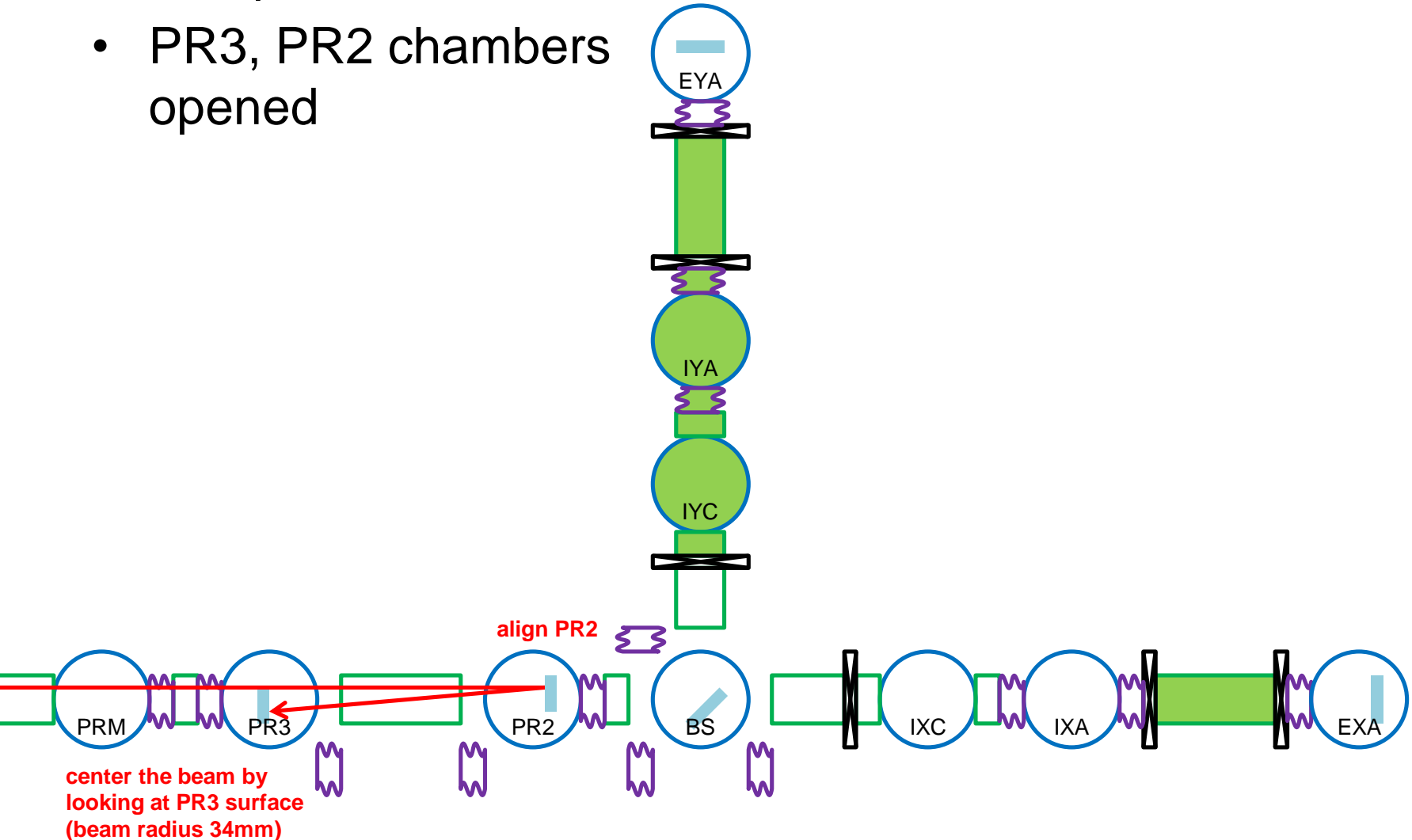

# Beam Profiling at PR3 (Mar 3)

- Measure the profile of the beam going to PR3
- tilt PR2 temporarily
- PR3, PR2 chambers opened

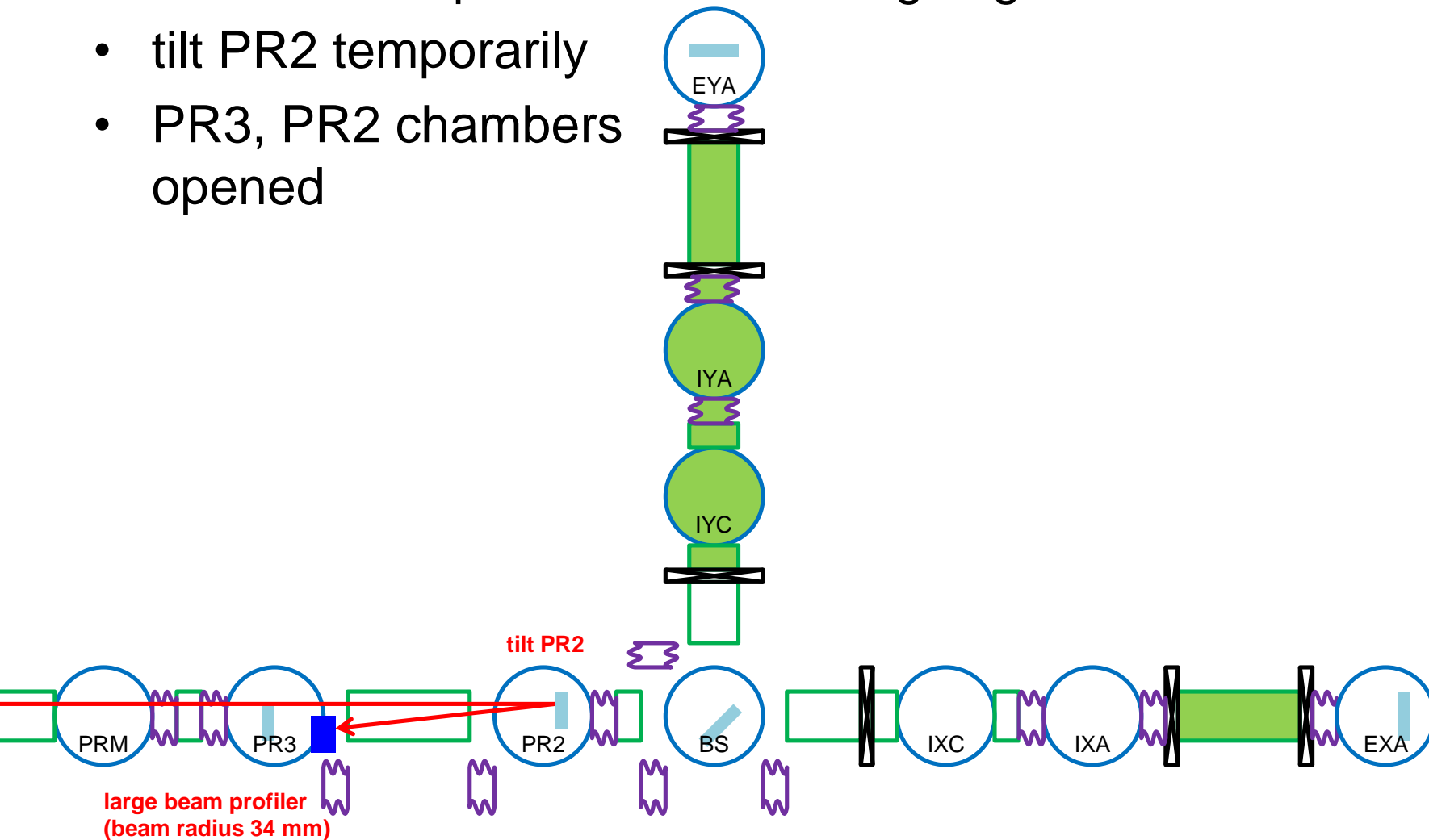

# PR3 Alignment (Mar 4)

- Use OSEMS on PR3 to center the beam on BS
- PR3, PR2, BS chambers opened

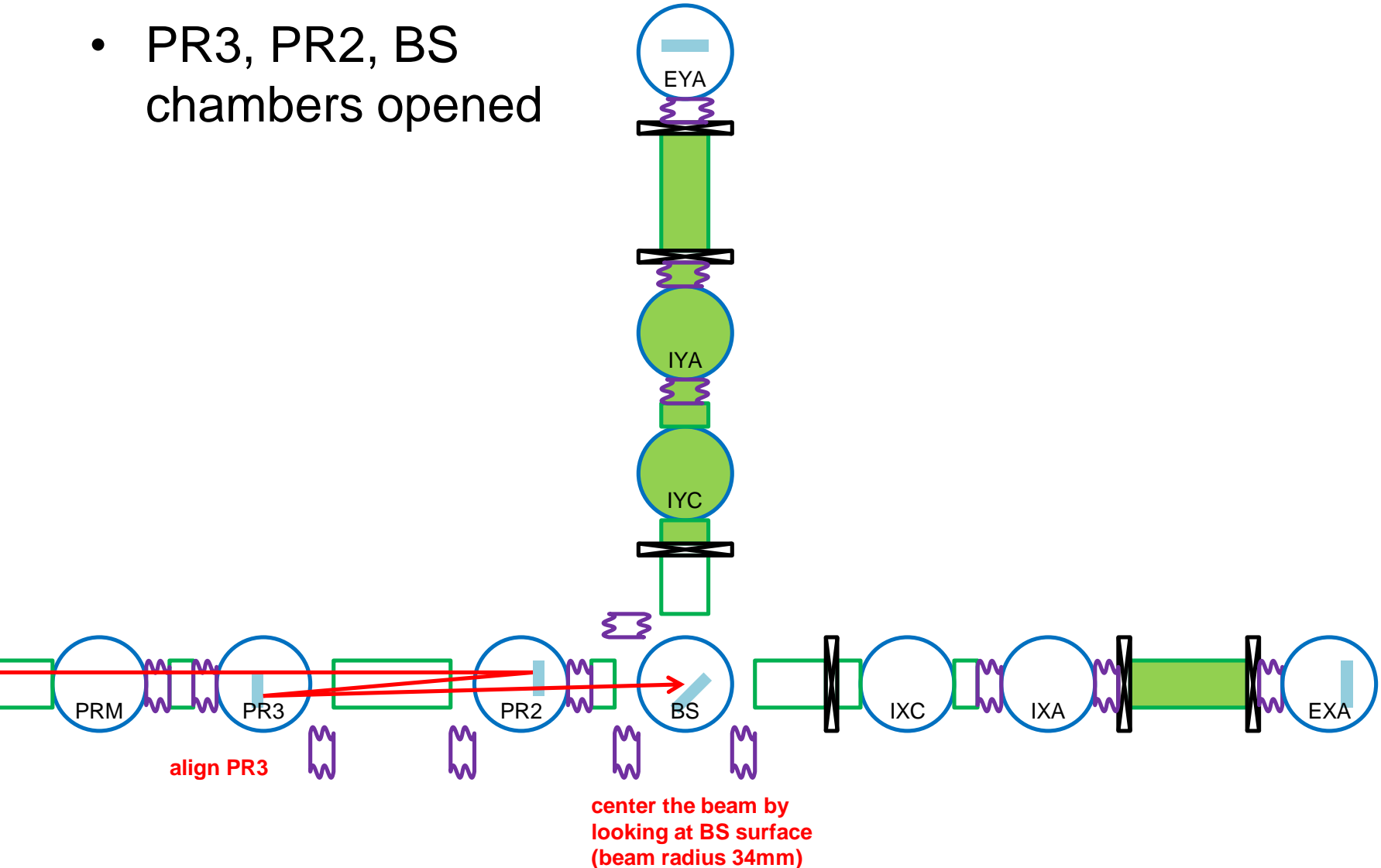

# Beam Profiling at IXA (Mar 4)

- Measure the beam profile at IXA
- If not well collimated, move PR2 and iterate
- PR3, PR2, BS, IXA chambers opened

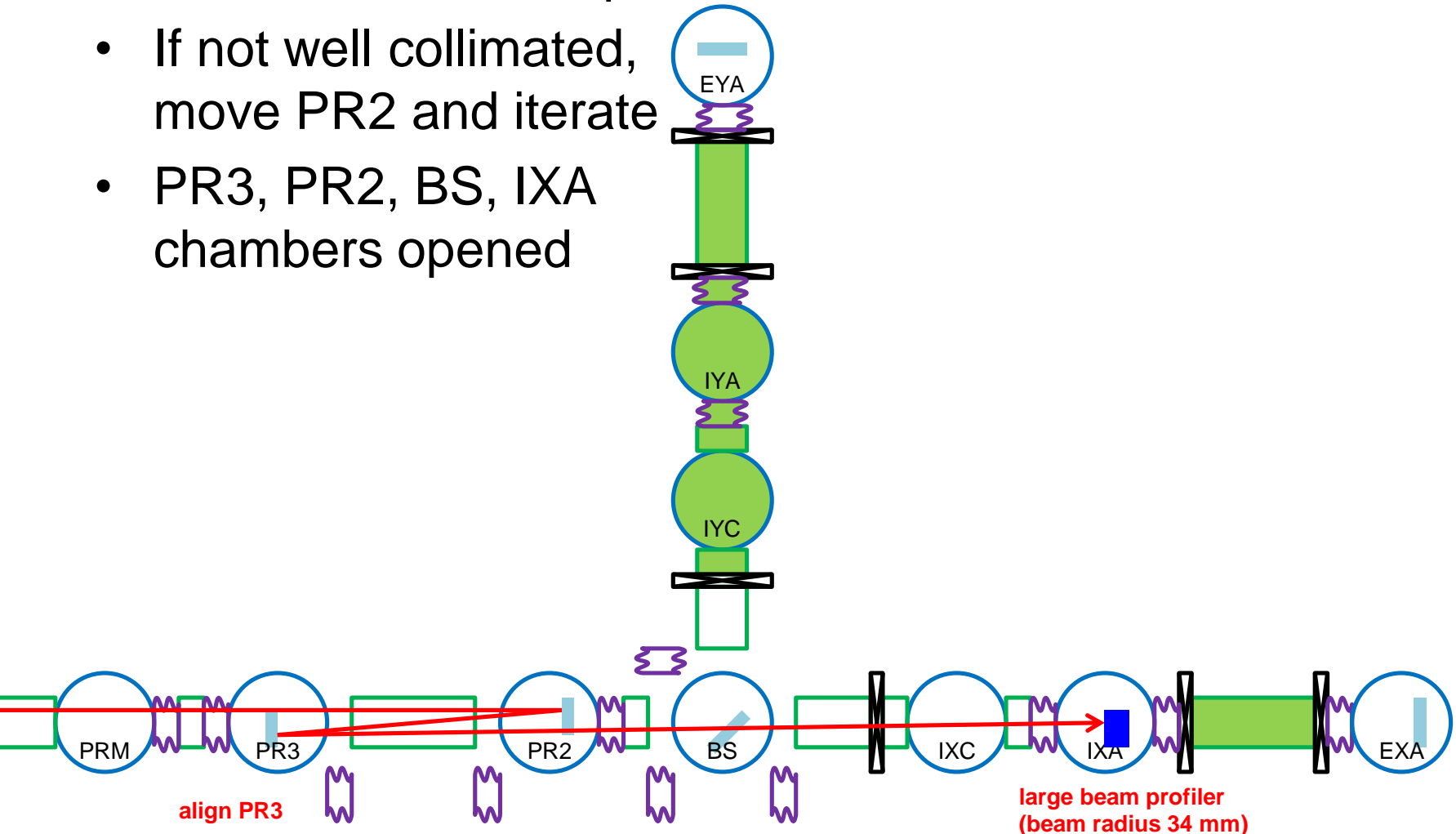



# Pointing to X Arm (Mar 4-7)

- Put PD in EXA chamber, sweep PR3 alignment by OSEMs, and wait for the PD to get any signal
- PR3, PR2, BS, EXA chambers opened
- If no success, go to plan B

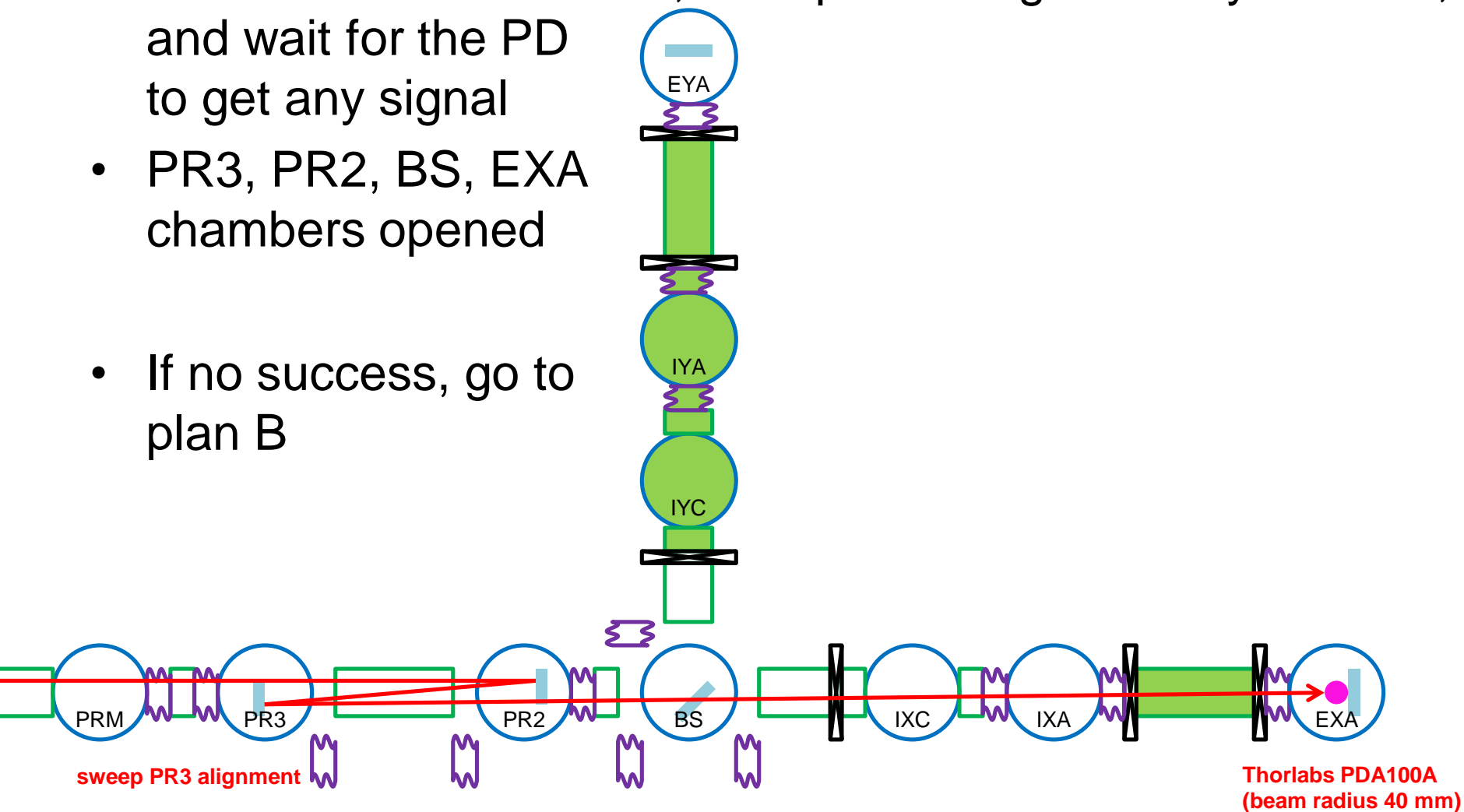

# Beam Profiling at EXA (Mar 7)

- Measure the beam profile at IXA (**this beam is clipped by  $\phi 10\text{mm}$  viewports**)
- PR3, PR2, BS, EXA chambers opened

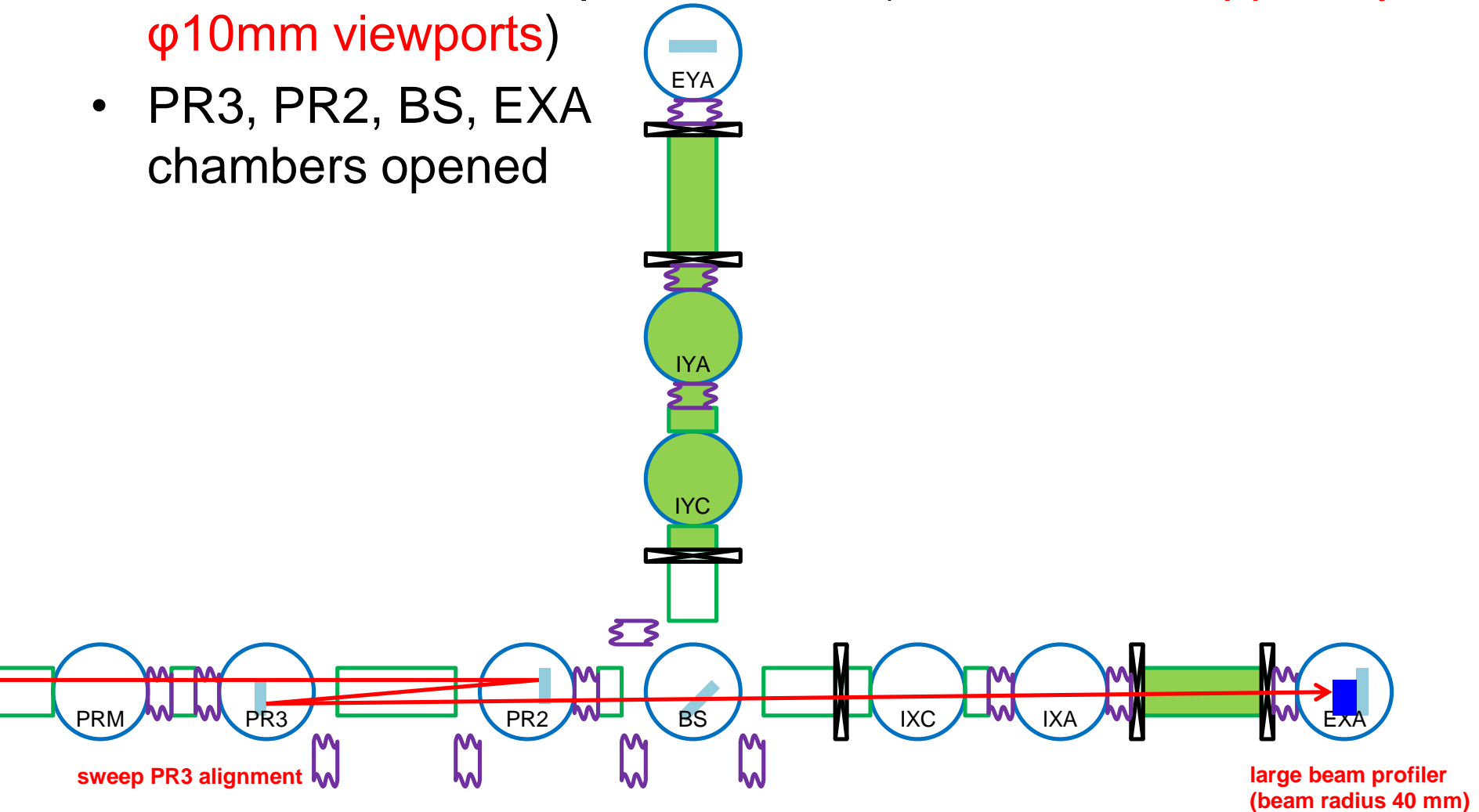

# Pointing Back from X Arm (Mar 8)

- Evacuate EXA if possible
- Put PD in BS chamber, sweep ETMX alignment by coils, and wait for the PD to get any signal
- PR3, PR2, BS chambers opened

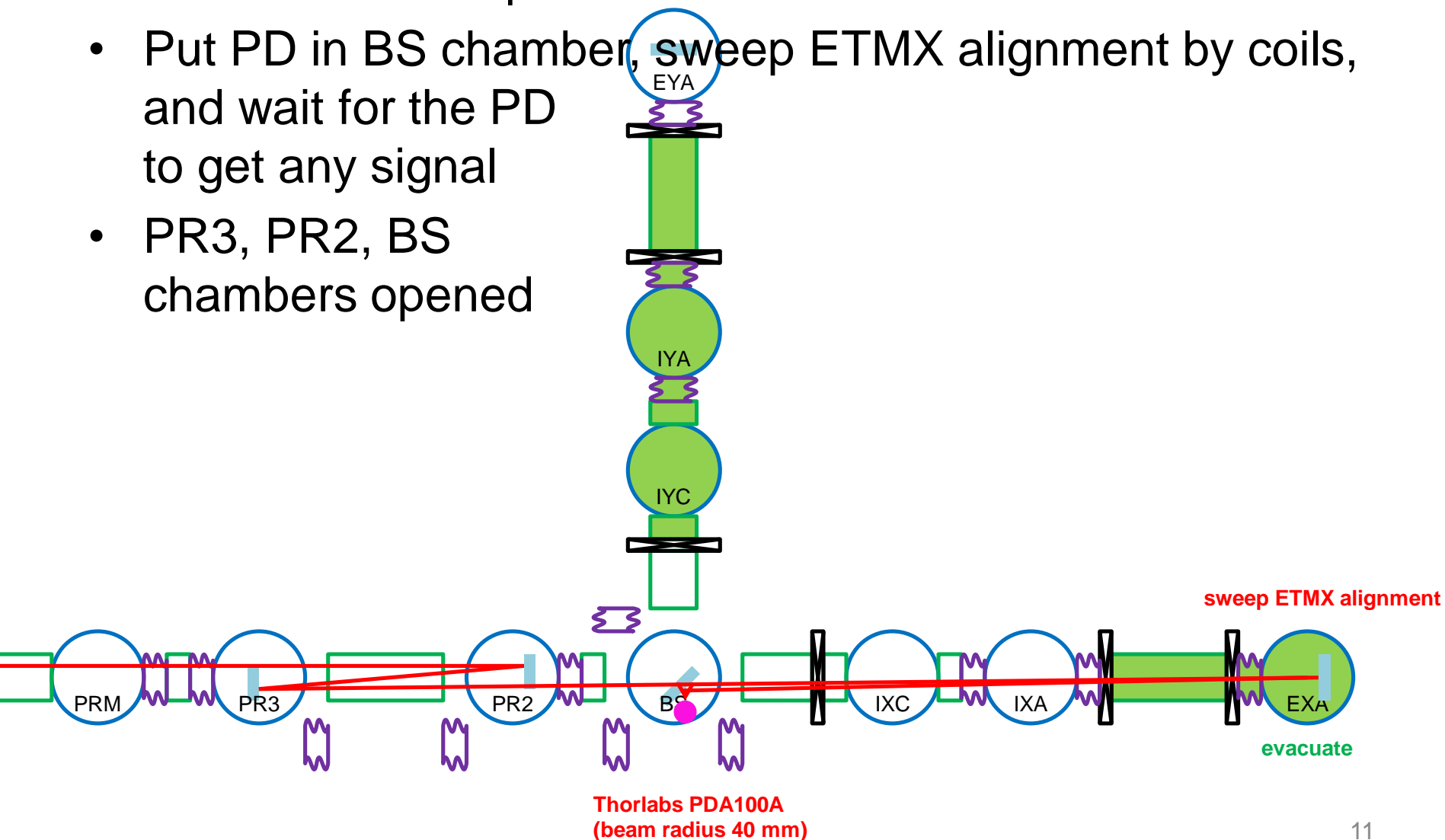

# Back to IFI (Mar 8)

- Adjust ETMX alignment to center the reflected beam on BS, PR3, PR2, and get the beam back to IFI and then REFL port
- PR3, PR2, BS chambers opened

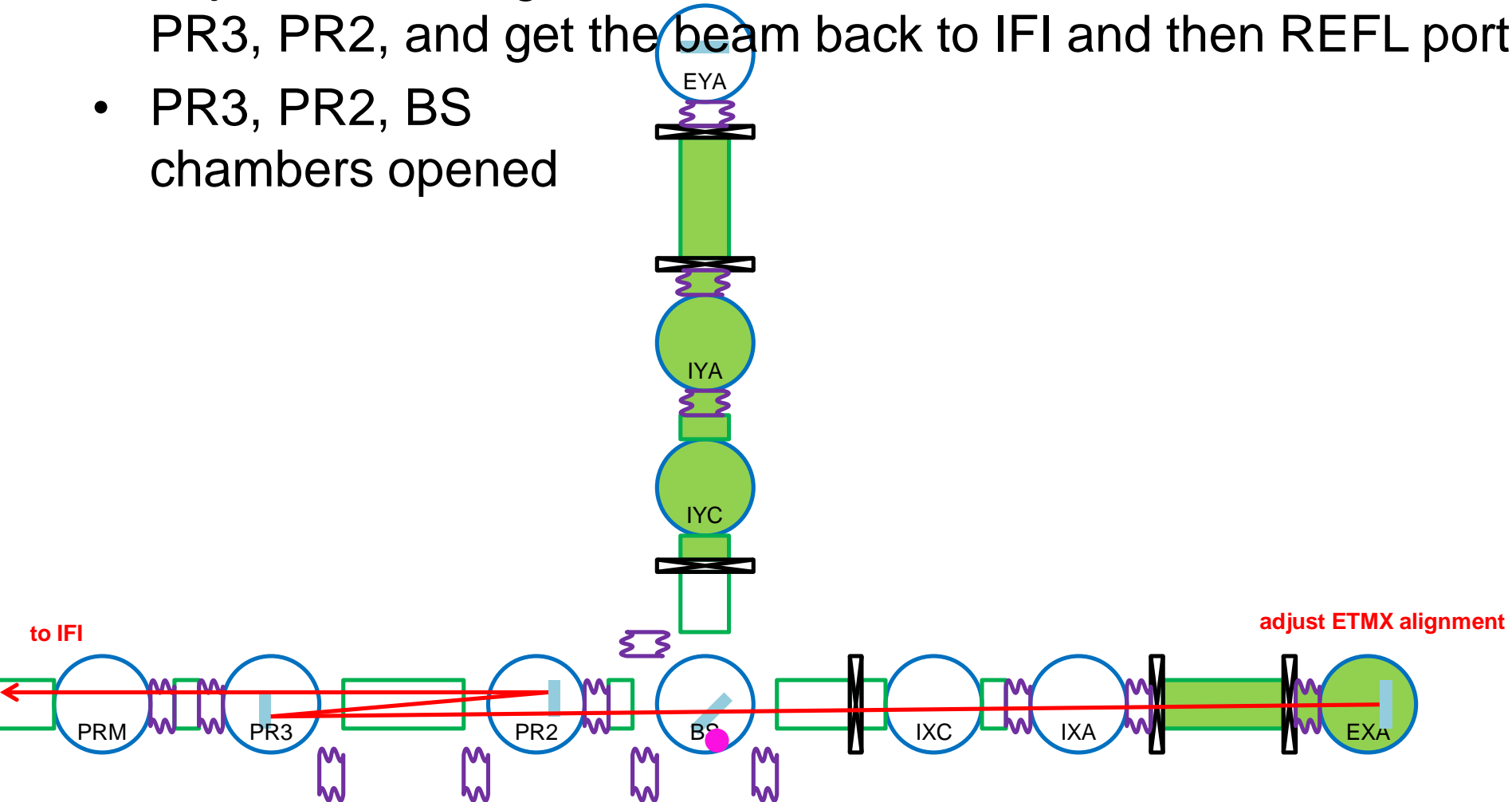

# Close X arm (Mar 9)

- Put X arm bellows, and evacuate X arm

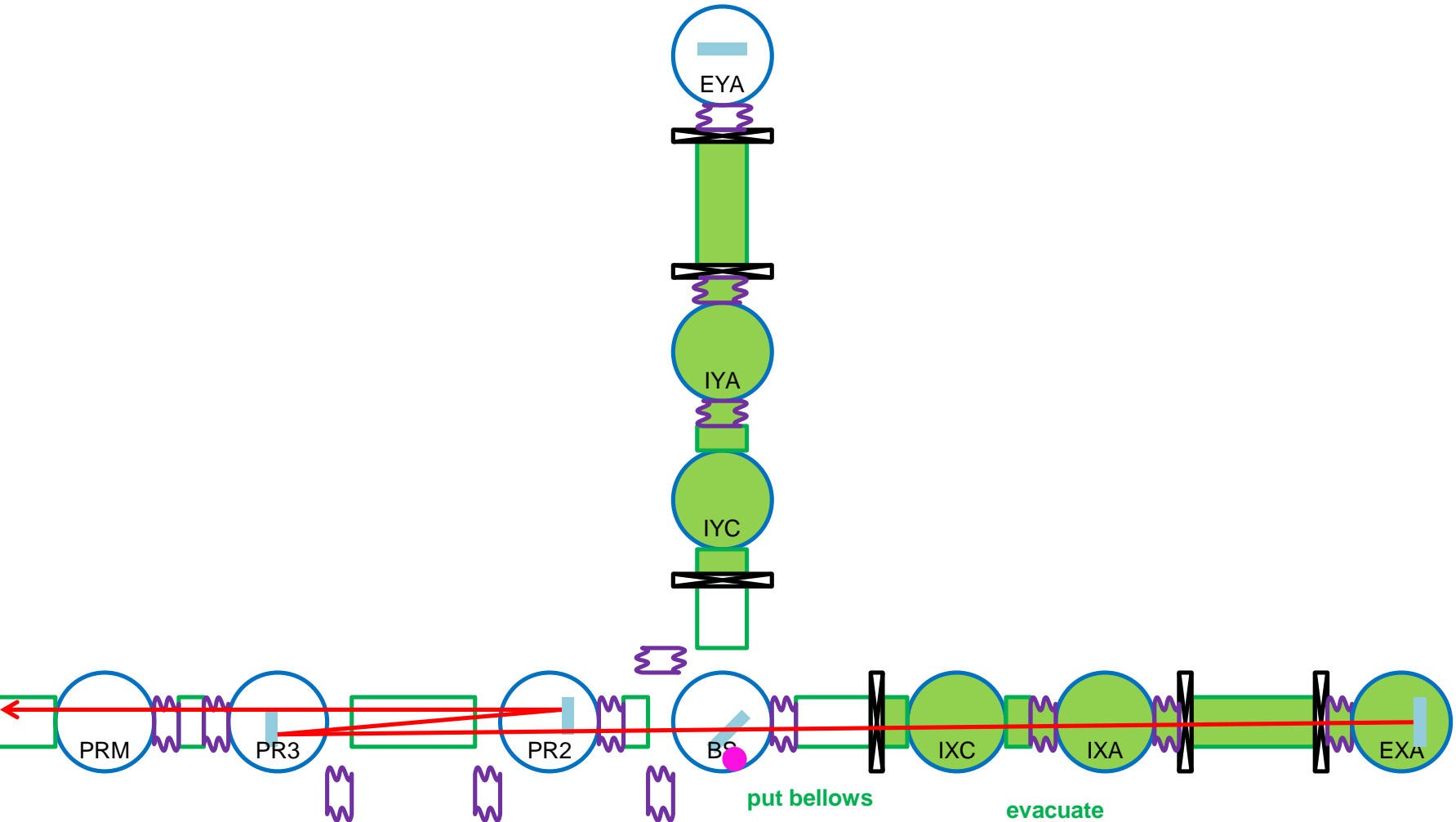

# Pointing to Y arm (Mar 9-10)

- Put PD in EYA chamber, sweep BS alignment by coils, and wait for the PD to get any signal
- PR3, PR2, BS, EYA chambers opened

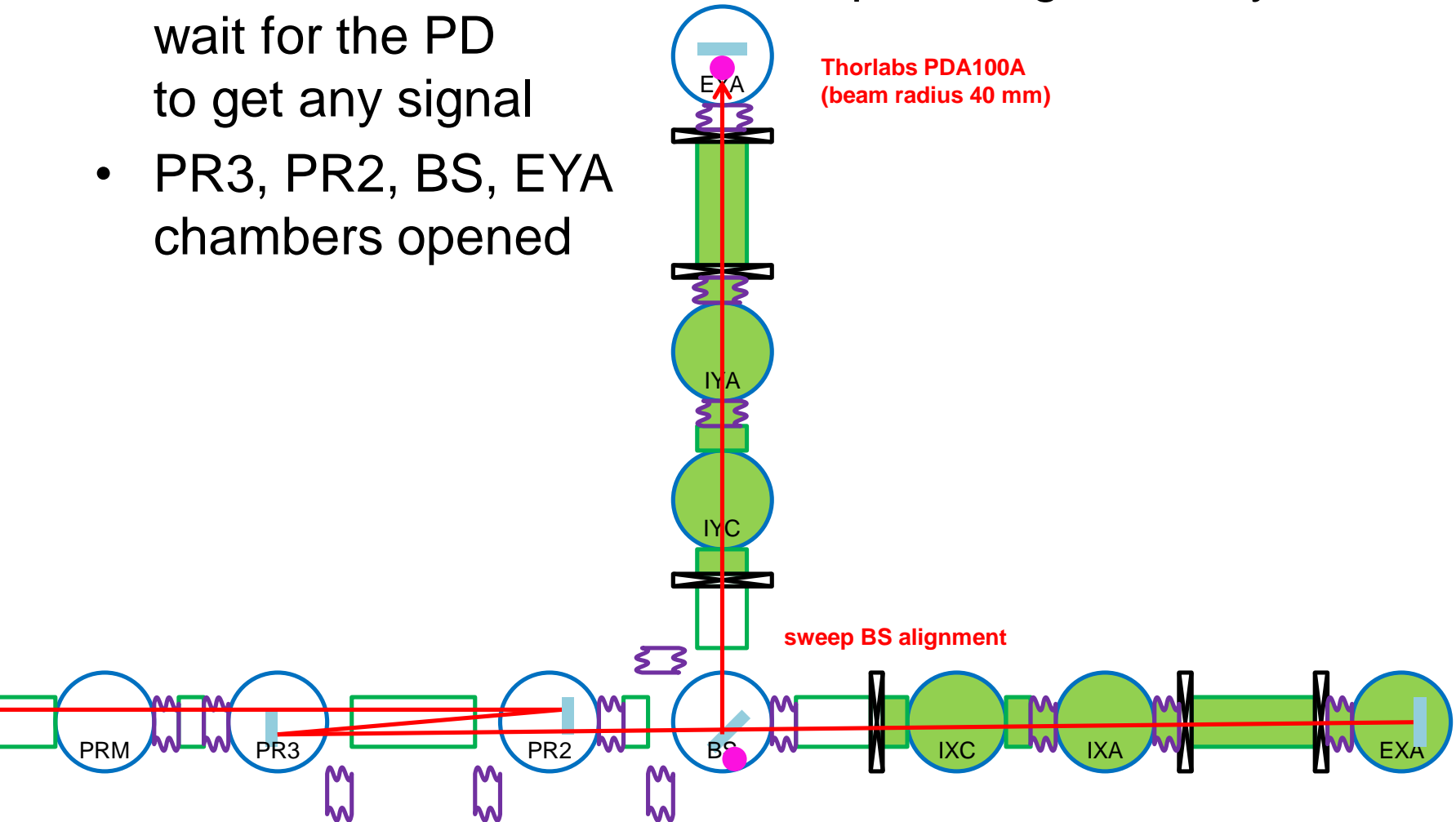

# Pointing Back from Y arm (Mar 11)

- Evacuate EYA if possible
- Put PD in BS chamber, sweep ETMY alignment by coils, and wait for the PD to get any signal (block X arm beam)
- PR3, PR2, BS chambers opened

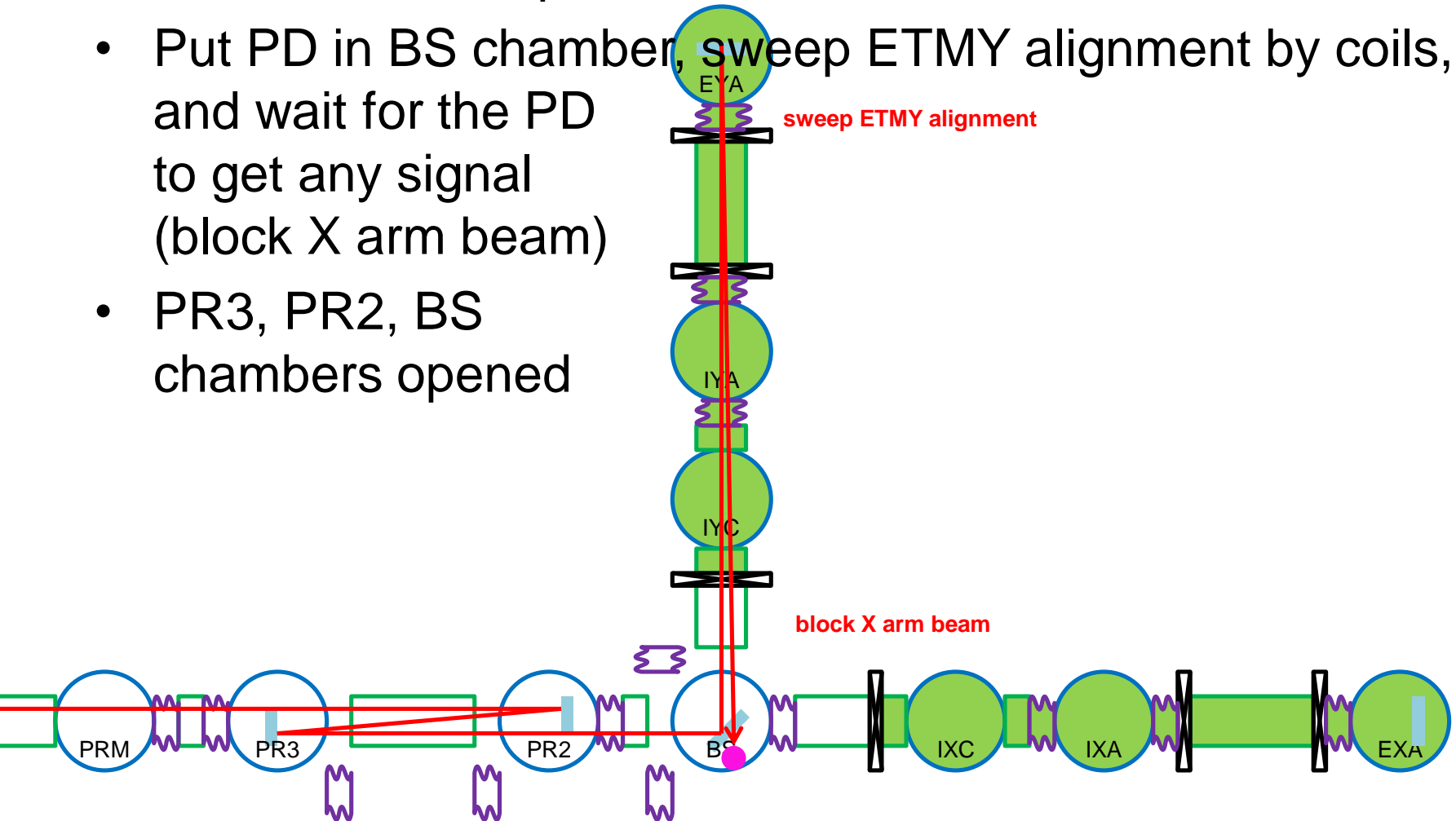

Thorlabs PDA100A  
(beam radius 40 mm)

# Get Fringe at REFL/AS (Mar 11)

- Unblock X arm beam and confirm fringing at REFL/AS
- PR3, PR2, BS chambers opened

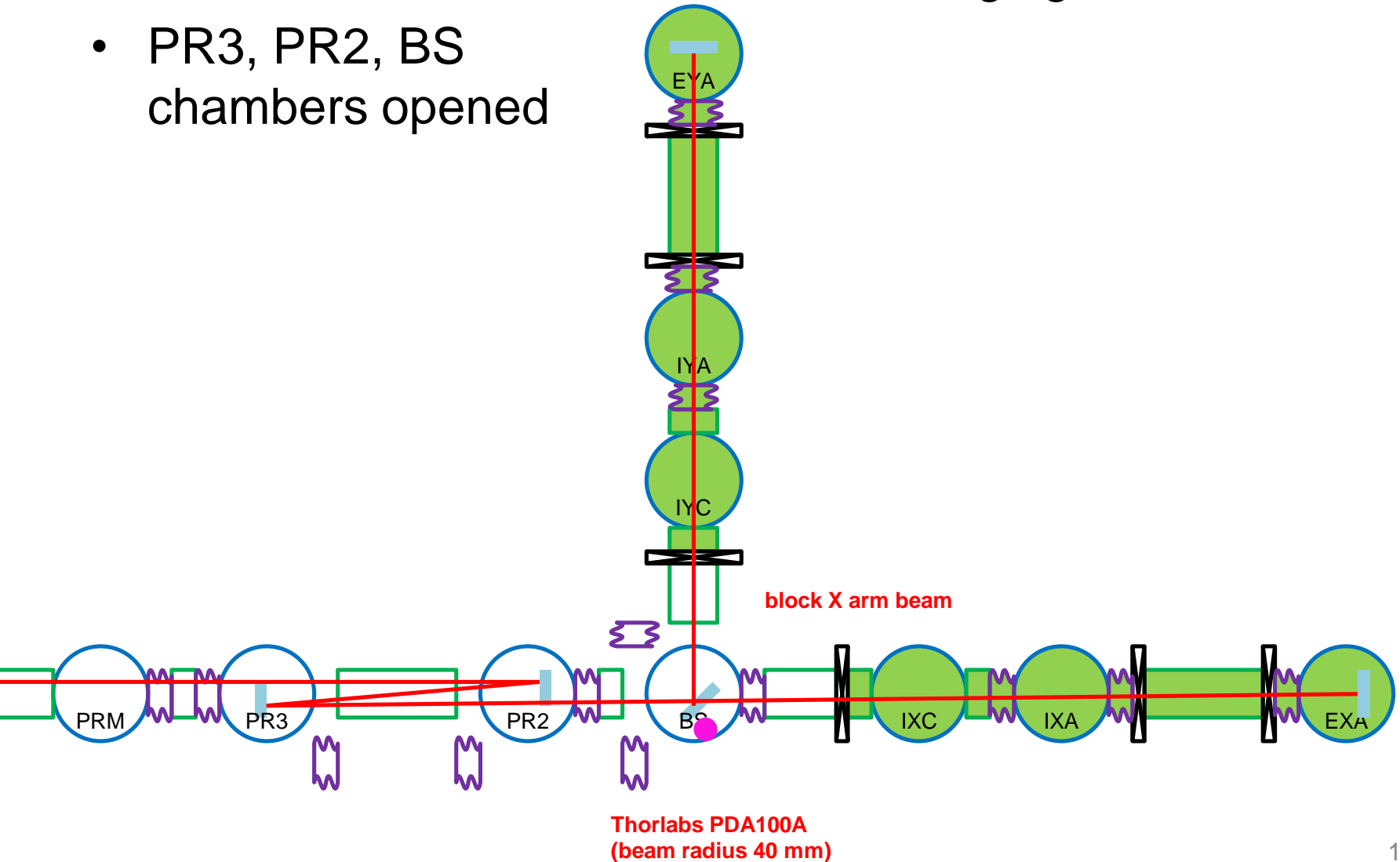



# Close Everything (Mar 12-13)

- Close remaining bellows and evacuate the whole IFO

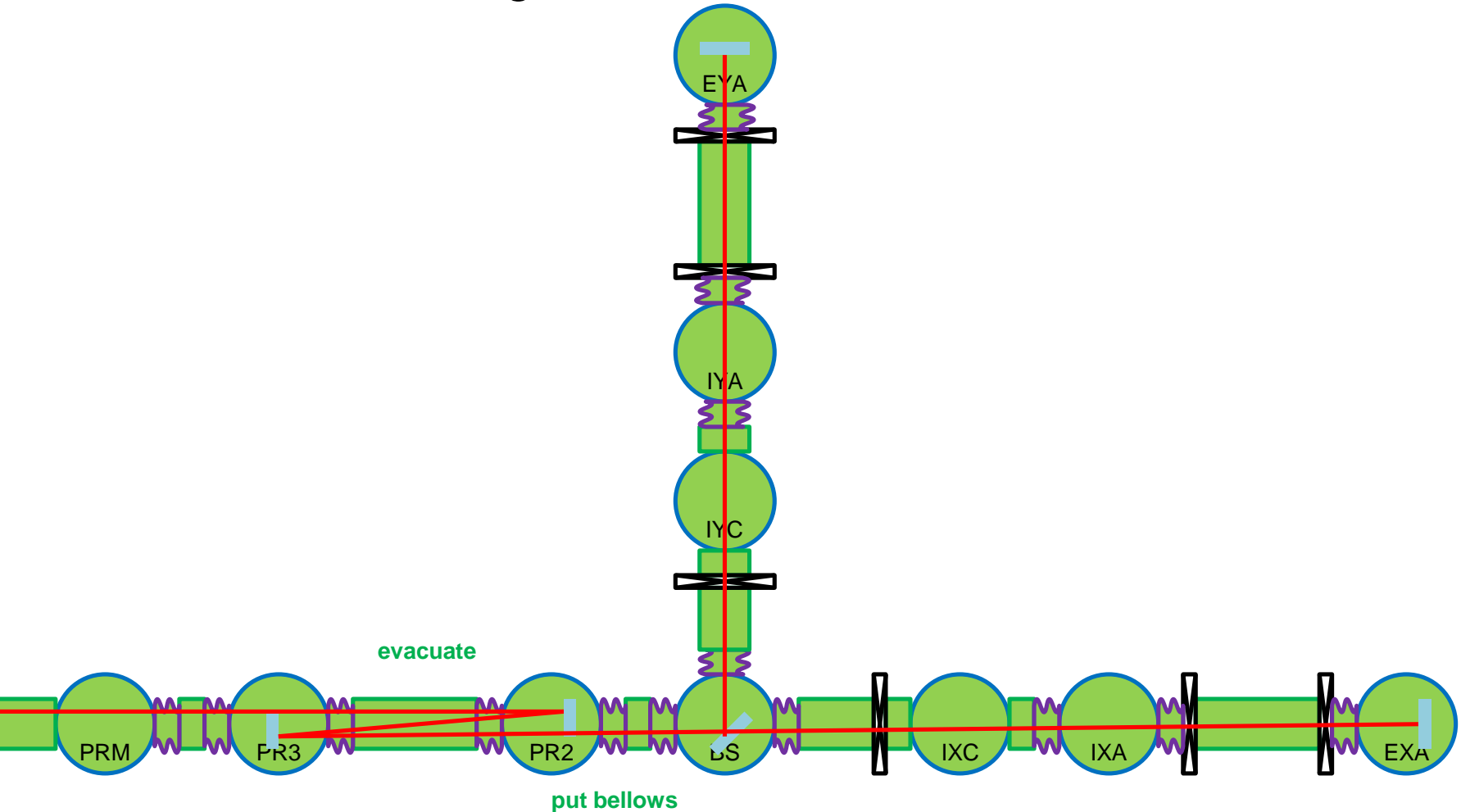

# Lock Michelson (Mar 14)

- Lock Michelson with REFL PD

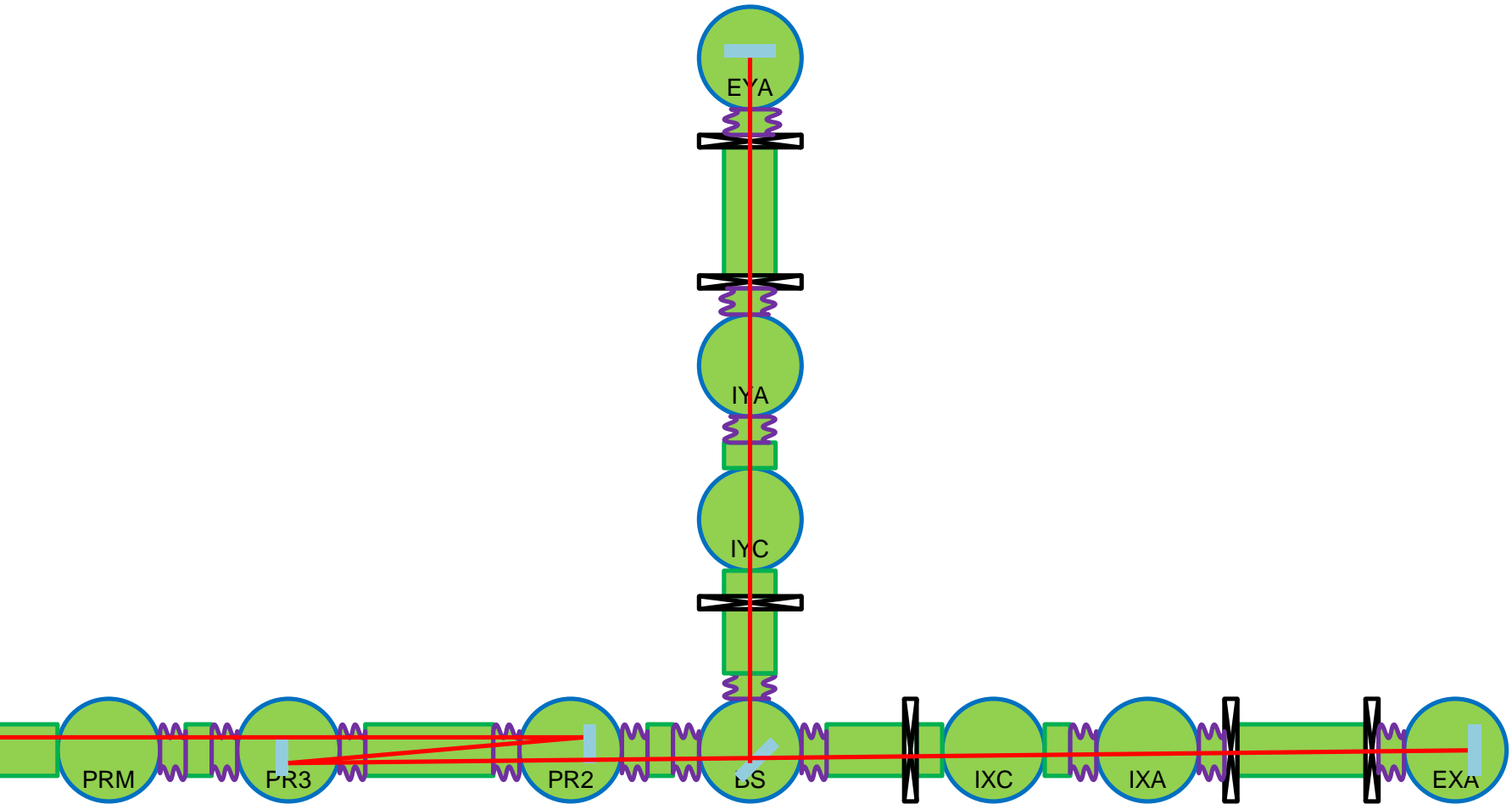

**Plan B**  
**(if we don't see the beam at EX)**

# Evacuate Central Part (Mar 8)

- Put AS screen in BS chamber, put all the bellows, and evacuate the central part
- Open gate valves at IX/IY

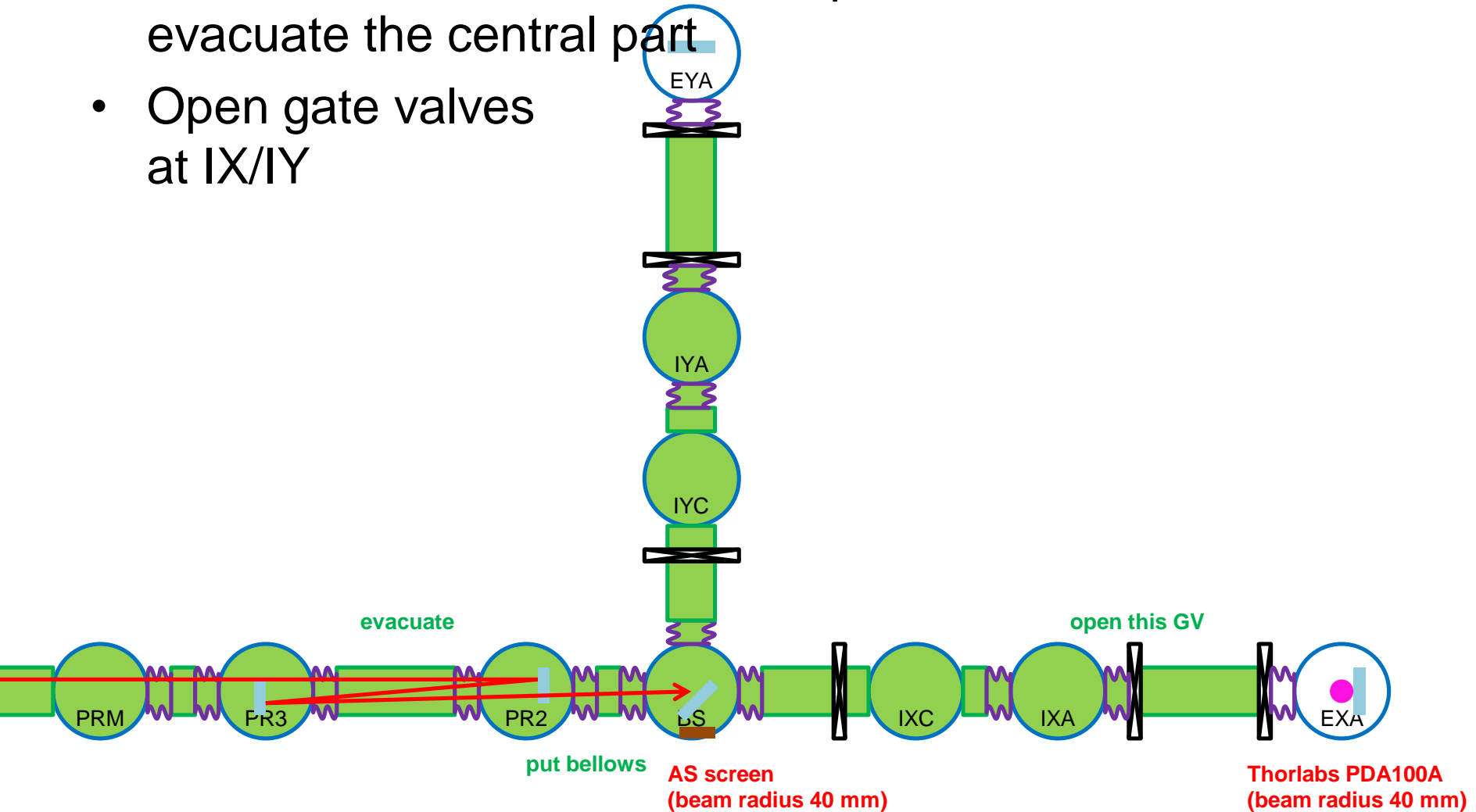

# All the rest

- Pointing to X arm (Mar 9)
- Back to IFI from X arm (Mar 10)
- Pointing to Y arm (Mar 11)
- Back to IFI from Y arm, and get fringing (Mar 12)
- Evacuate EXA and EYA (Mar 13)
- Lock Michelson (Mar 14)
  
- We skip beam profiling at EXA
- Use cameras/screens/irises(?) after evacuation of the central part