

KAGRA 用防振装置の開発 XVII (インストール)

藤井善範

東京大学 理学系研究科 天文学専攻

国立天文台 重力波プロジェクト推進室

高橋竜太郎, 正田亜八香, Fabian Pena Arellano, Mark Barton, 阿久津智忠, 平田直篤,
石崎秀晴, 大淵喜之, 浦口史寛, 池之上文吾, 斎藤栄, 大石奈緒子,
麻生洋一(国立天文台), 奥富弘基(総研大), Ettore Majorana(INFN Rome),
Joris van Heijningen, 我妻一博(NIKHEF), Riccardo DeSalvo(Univ. Sannio),
宮川治, 上泉真裕, 内山隆, 山元一広(東大宇宙線研), Raffaele Flaminio(国立天文台)

Contents

◆ はじめに / KAGRA

□ PR3 防振装置

□ Installation @ 神岡KAGRAサイト

□ 組み立て手順

□ 干渉計での利用

□ まとめ

❖はじめに : KAGRA

大型低温重力波検出器 KAGRA

* 2016年3月末に試運転開始予定
(iKAGRA)

→ 3 km のマイケルソン干渉計

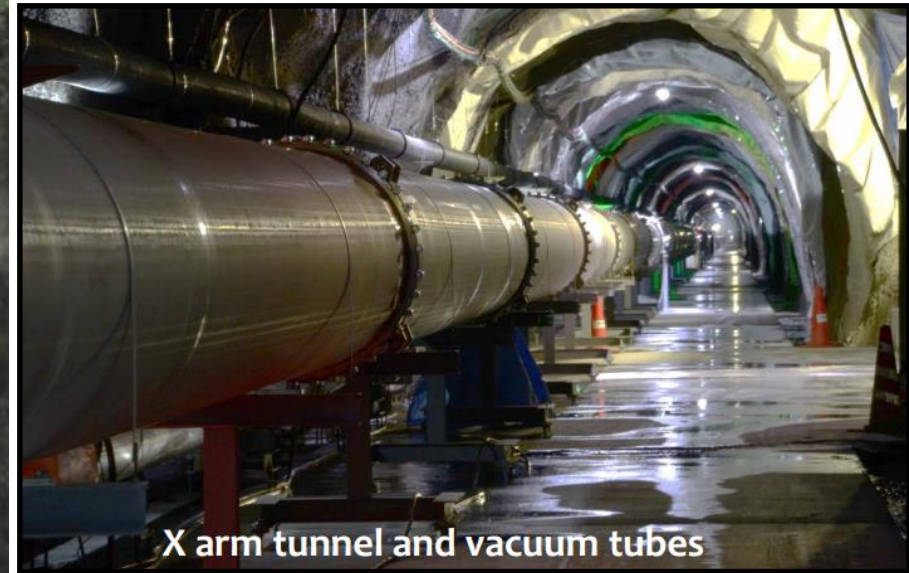
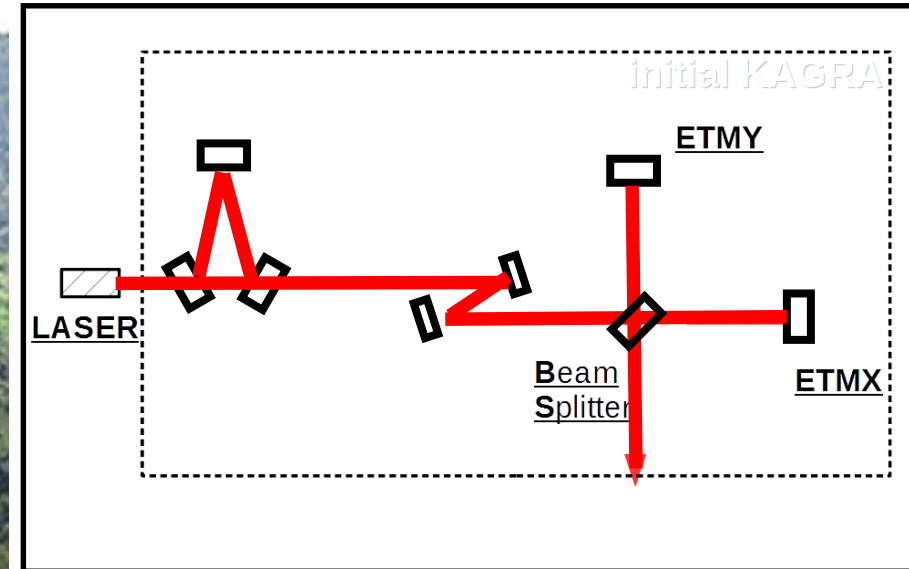

◆はじめに : KAGRA

今回は iKAGRA 干渉計の調整用鏡 PR3 の installation について。

目的 :

- 1) 調整用鏡をインストール → 使用
- 2) KAGRAの防振装置のインストール手順の確認

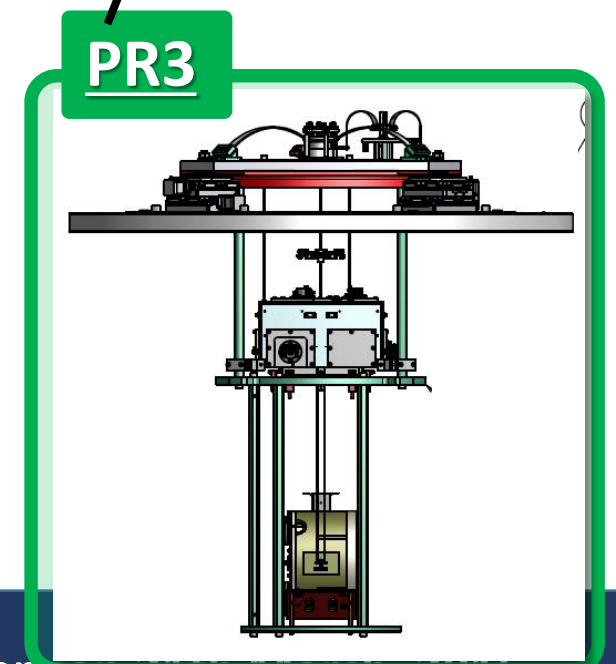
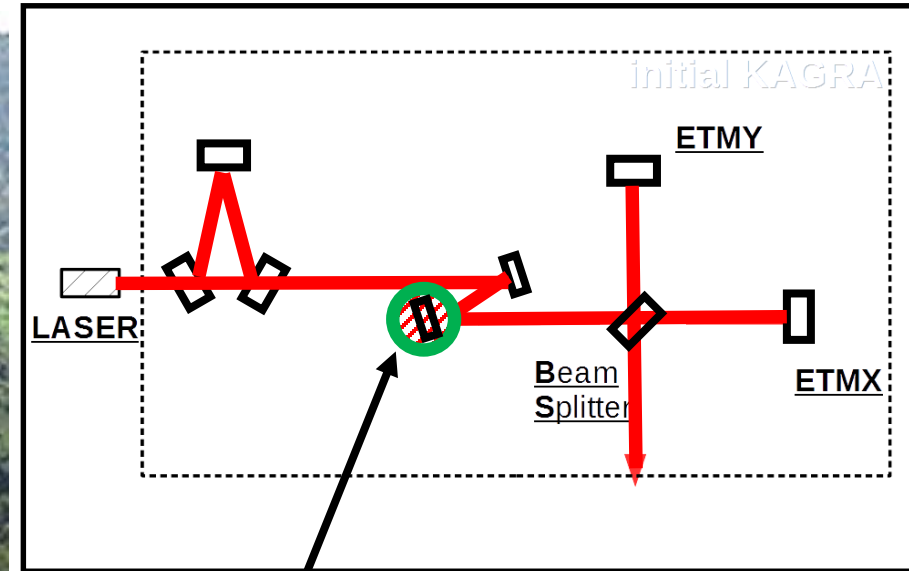

Contents

□ はじめに / KAGRA

◆ PR3 防振装置

□ Installation @ 神岡KAGRAサイト

□ 組み立て手順

□ 干渉計での利用

□ まとめ

◆ PR3 防振装置 / メカの構成

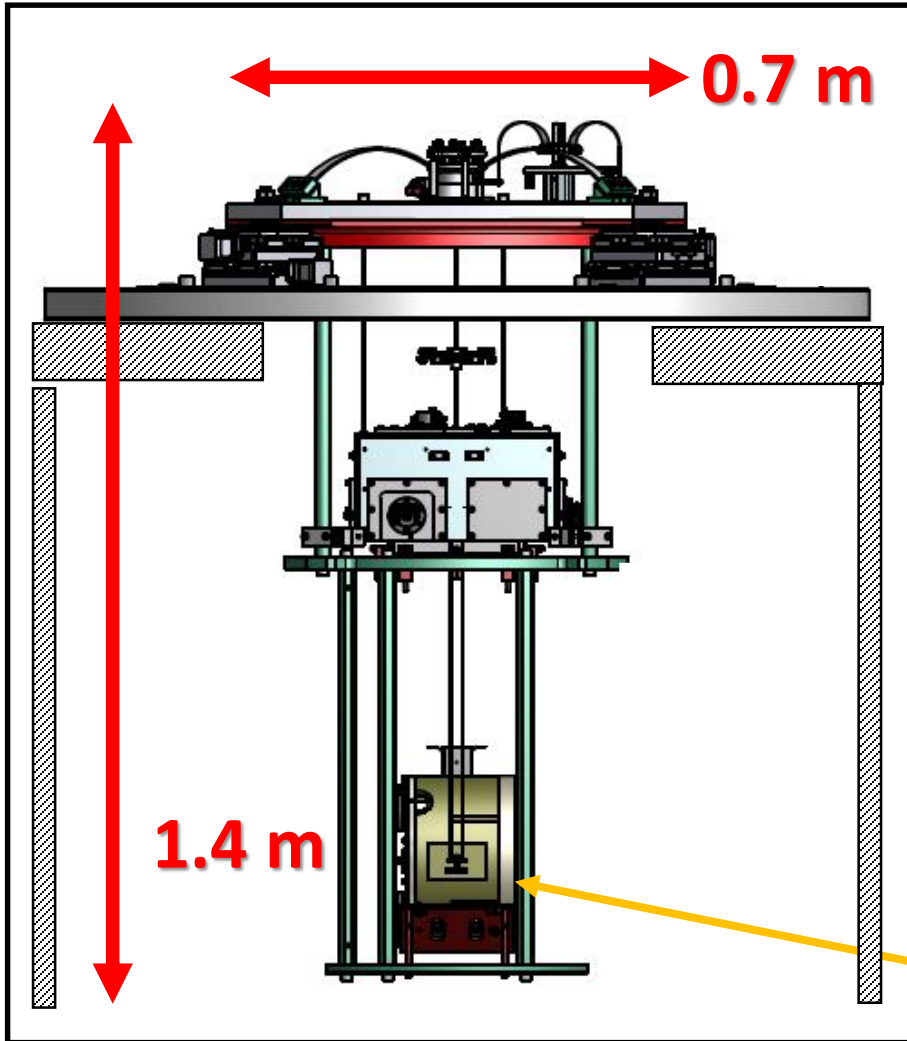

iKAGRA での
PR3用 防振装置
(TypeBp')

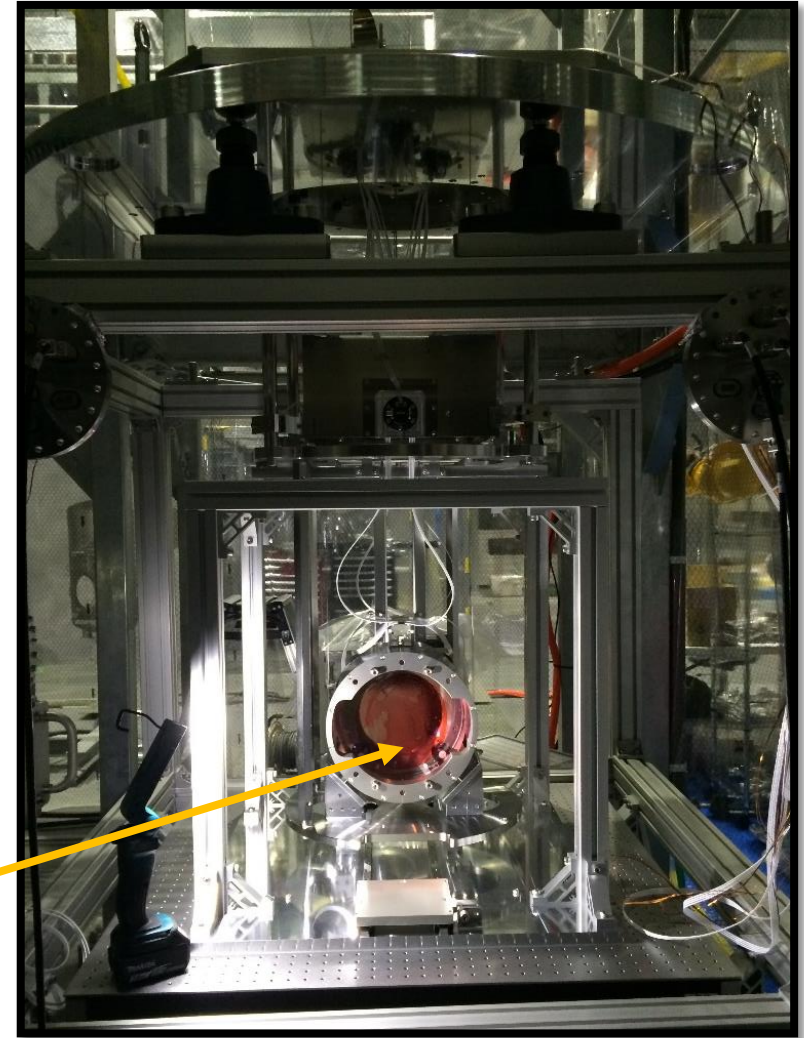

❖ PR3 防振装置 / メカの構成

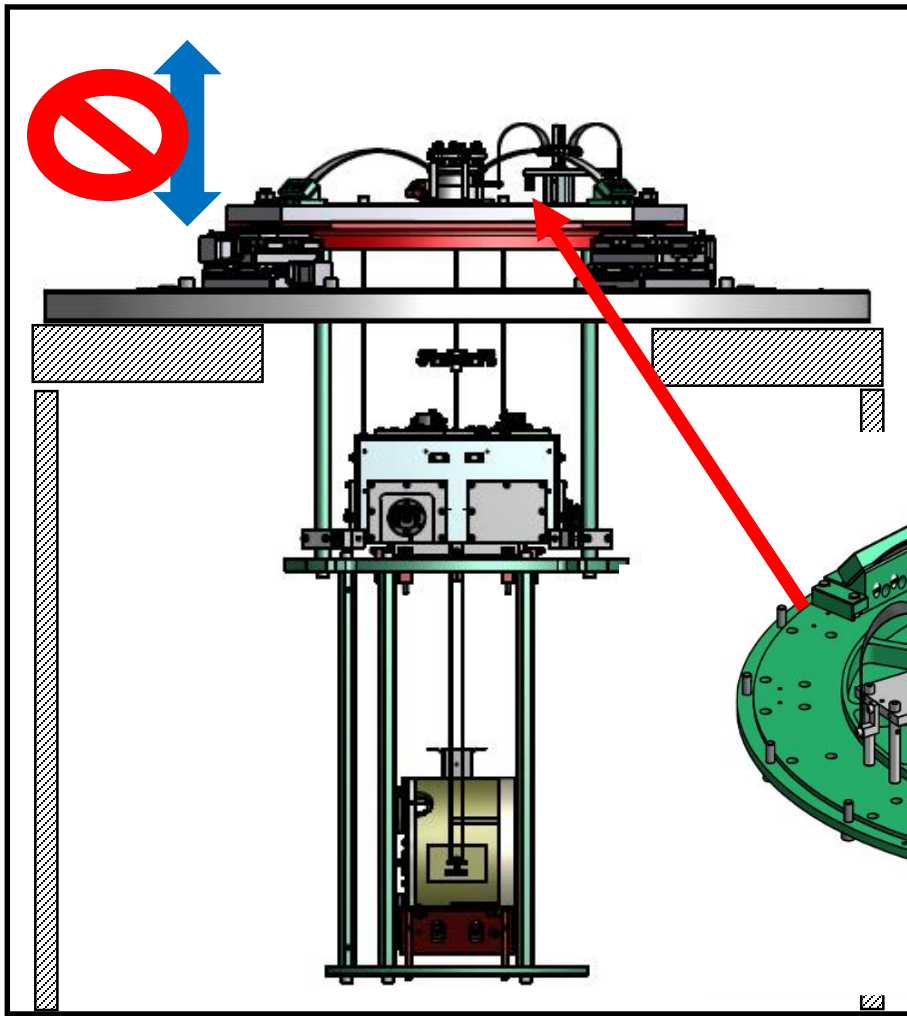

Geometric Anti-Spring(GAS) Filter ;
垂直方向の防振に必要。1 段使用

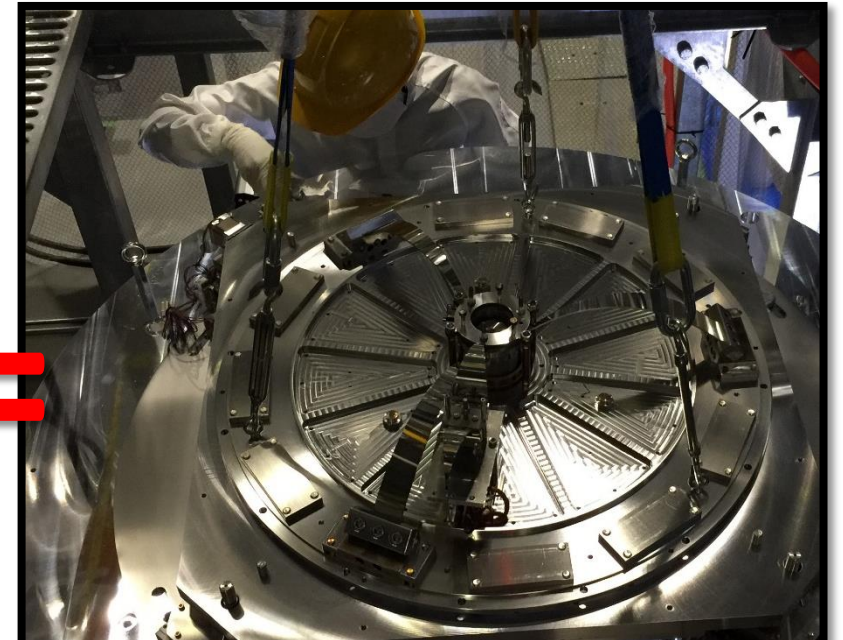
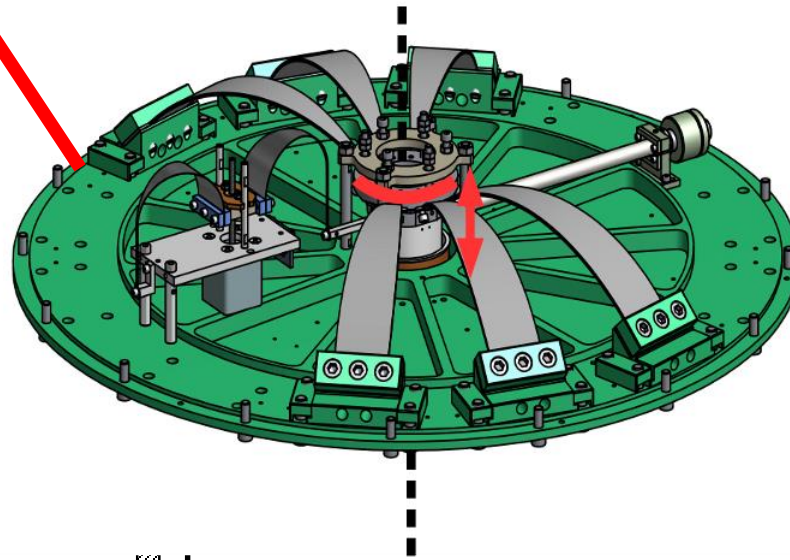

◆ PR3 防振装置 / メカの構成

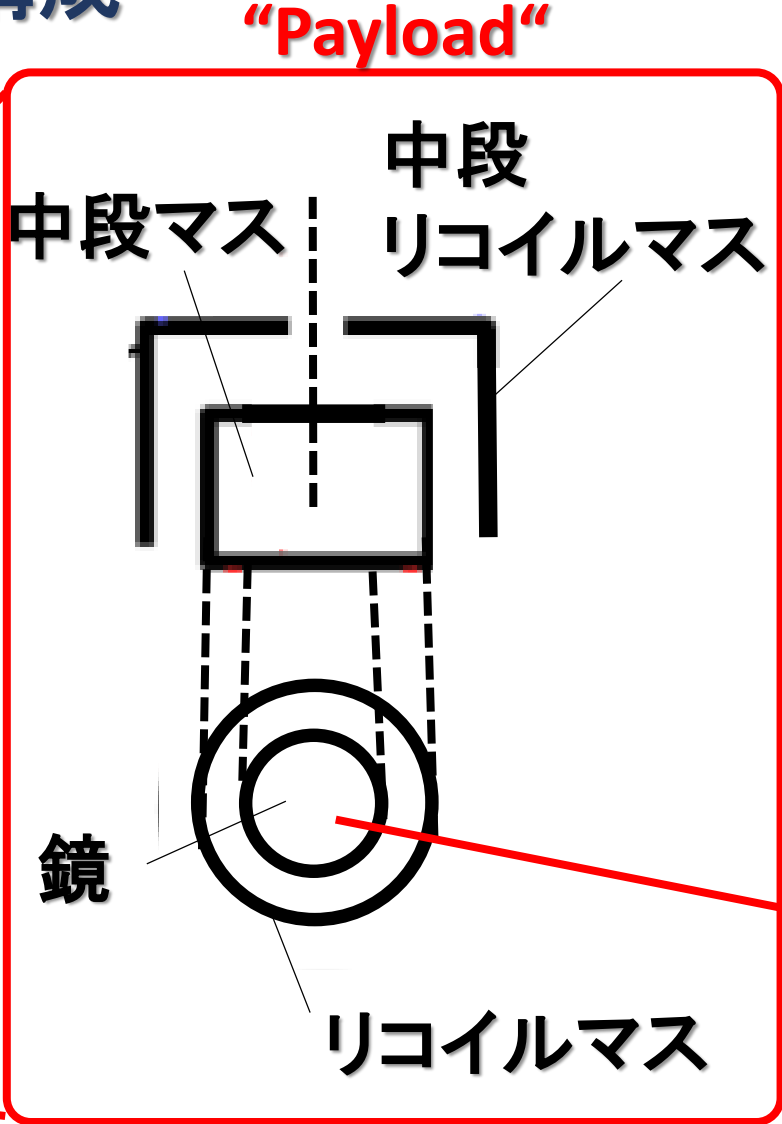
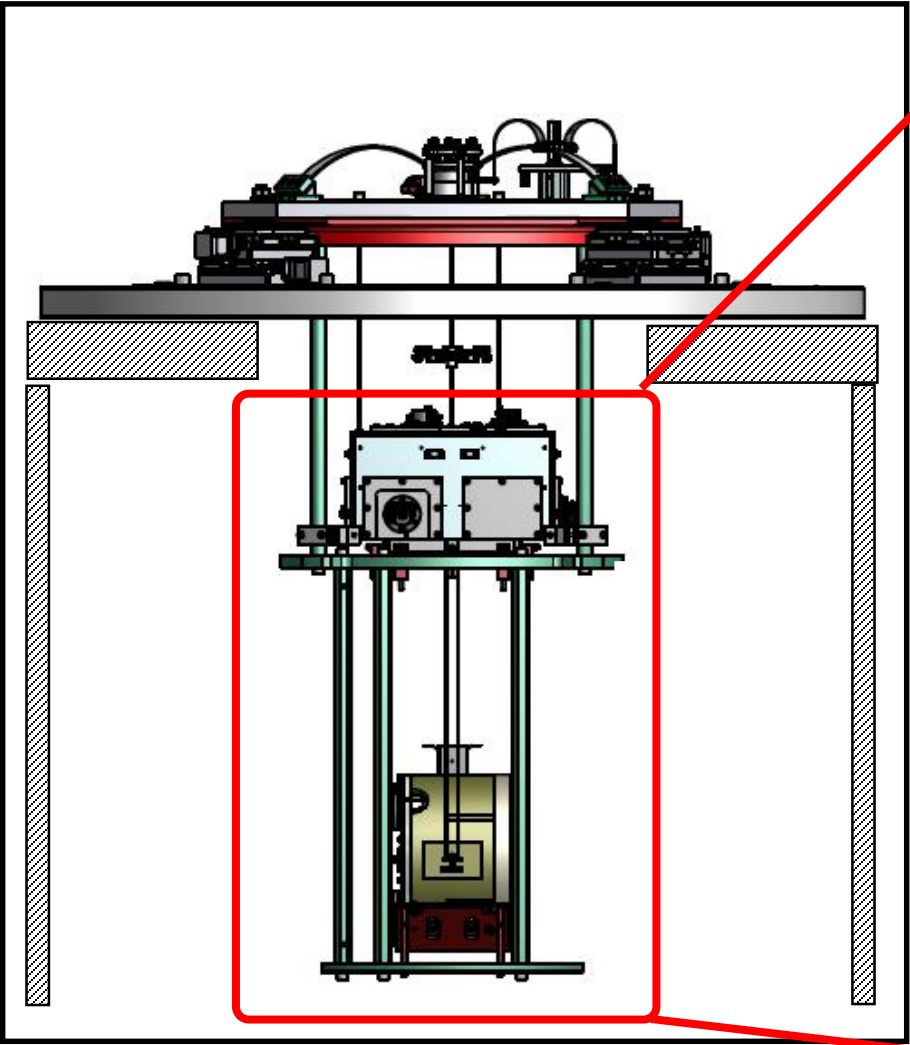

鏡とその覆いとの、
相対的な傾きの
微調整を行う。

現在鏡は
リコイルマスに
固定。

◆ PR3 防振装置 / 初期アライメント機構

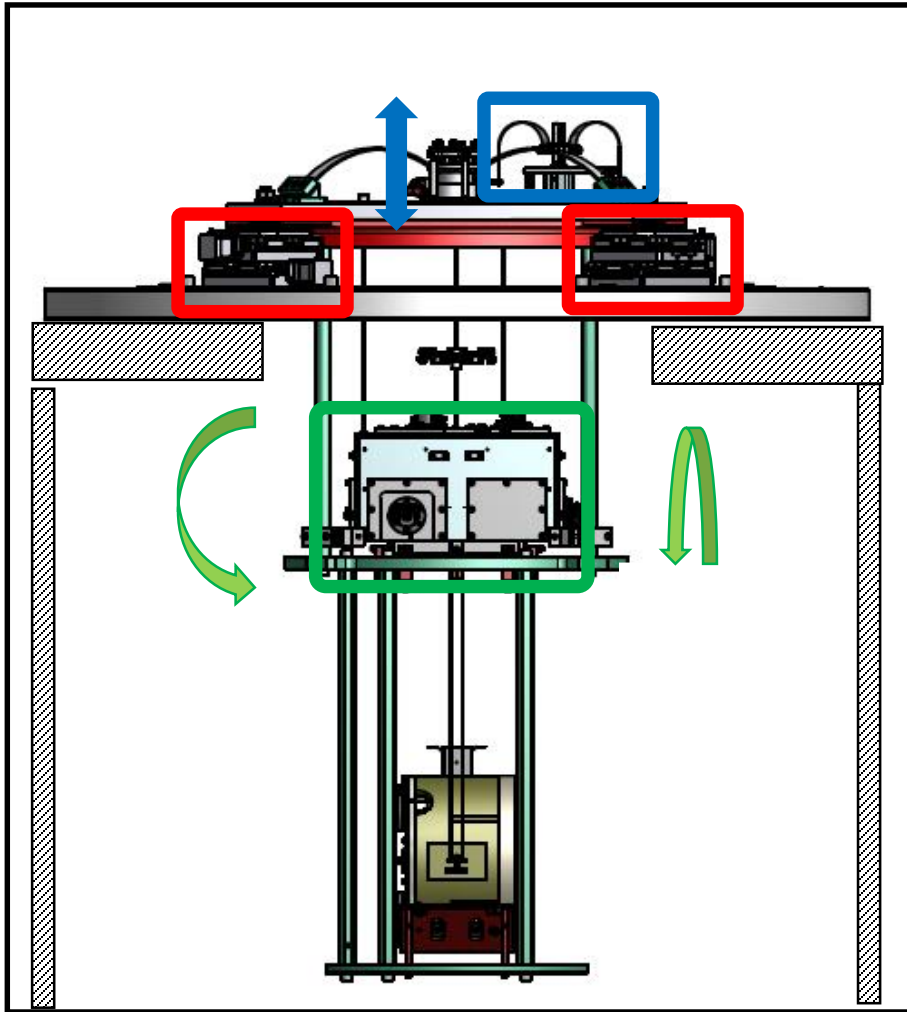

“Traverser”

防振装置全体の
並進2軸方向と
垂直軸周りの回転方向

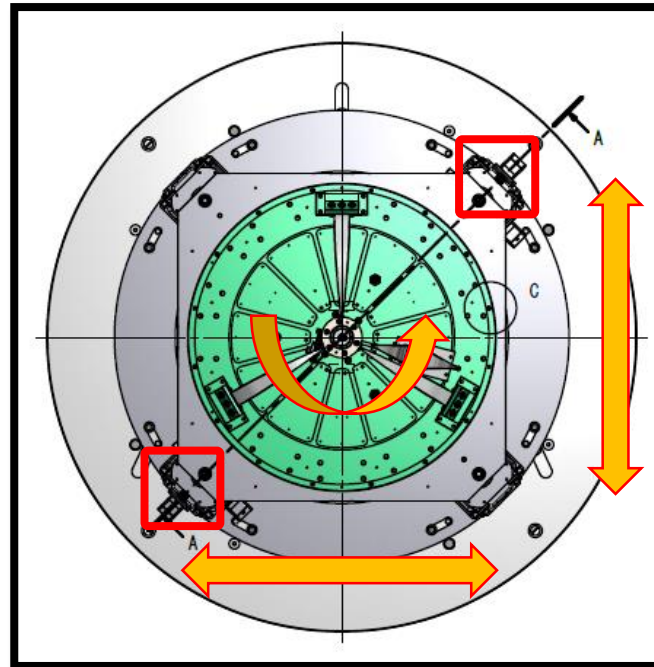

“Fishing rod”

鏡の垂直軸方向

DC tilt adjustment

中段マスの回転
2方向

◆ PR3 防振装置 / センサ, アクチュエータ

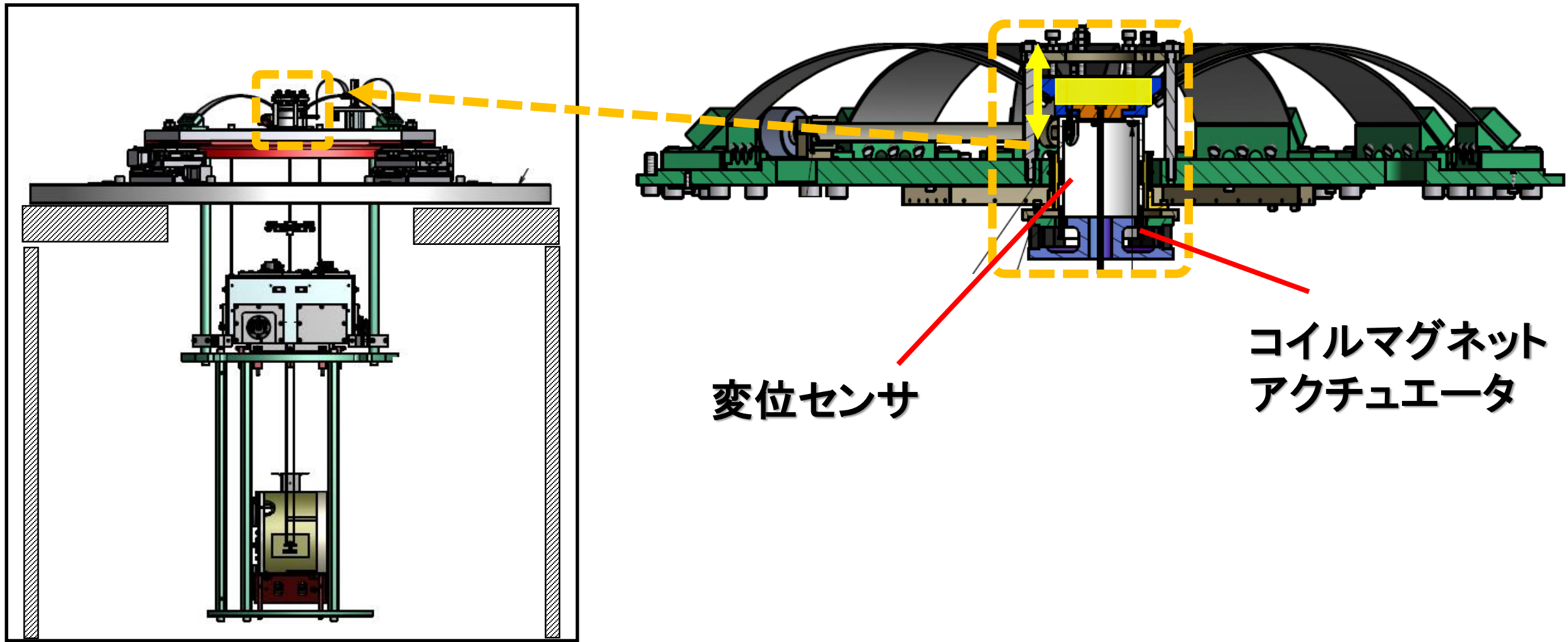

❖ PR3 防振装置 / センサ, アクチュエータ

Optical Sensors and Electro-Magnetic Actuators

→ シャドウセンサ & コイルマグネット アクチュエータ

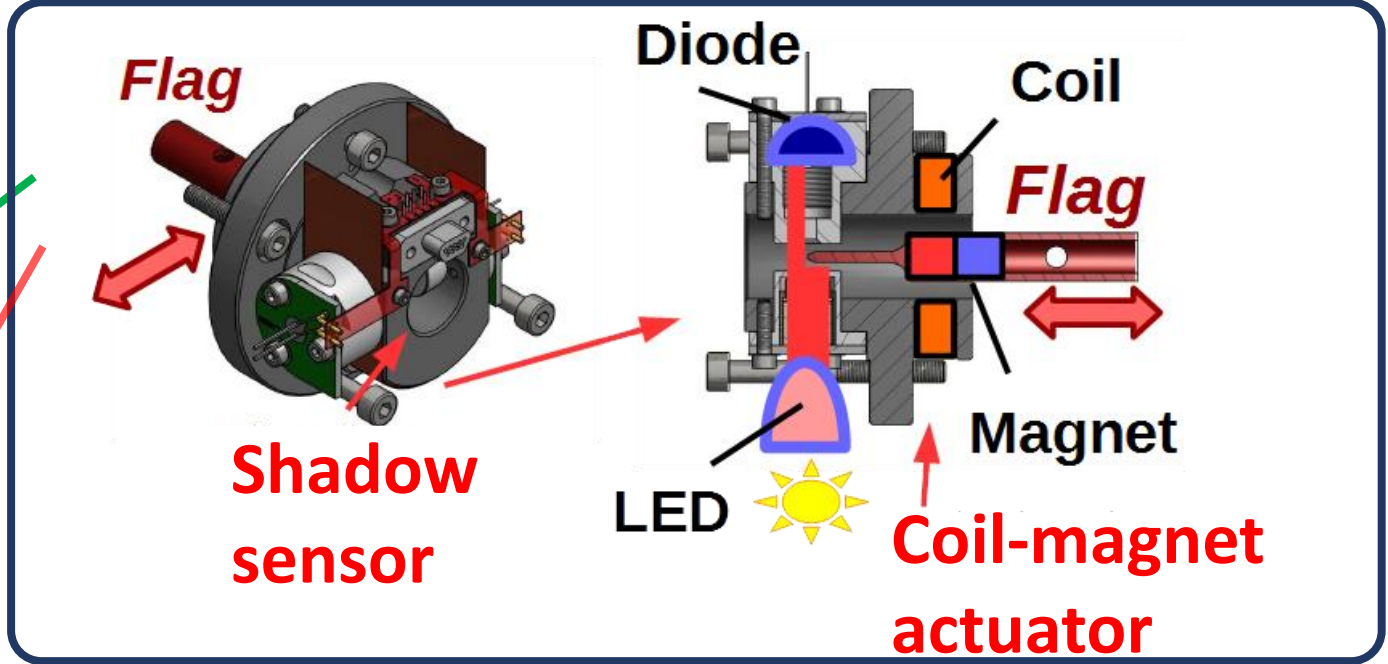
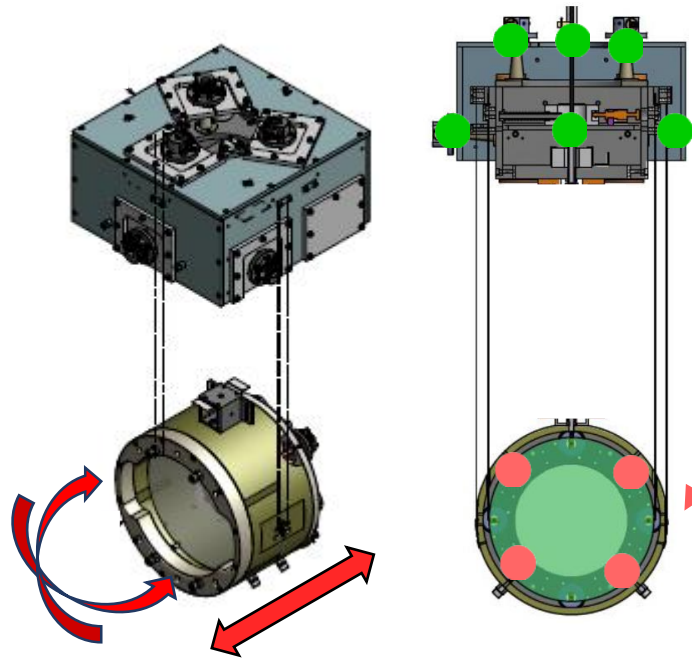

Flag

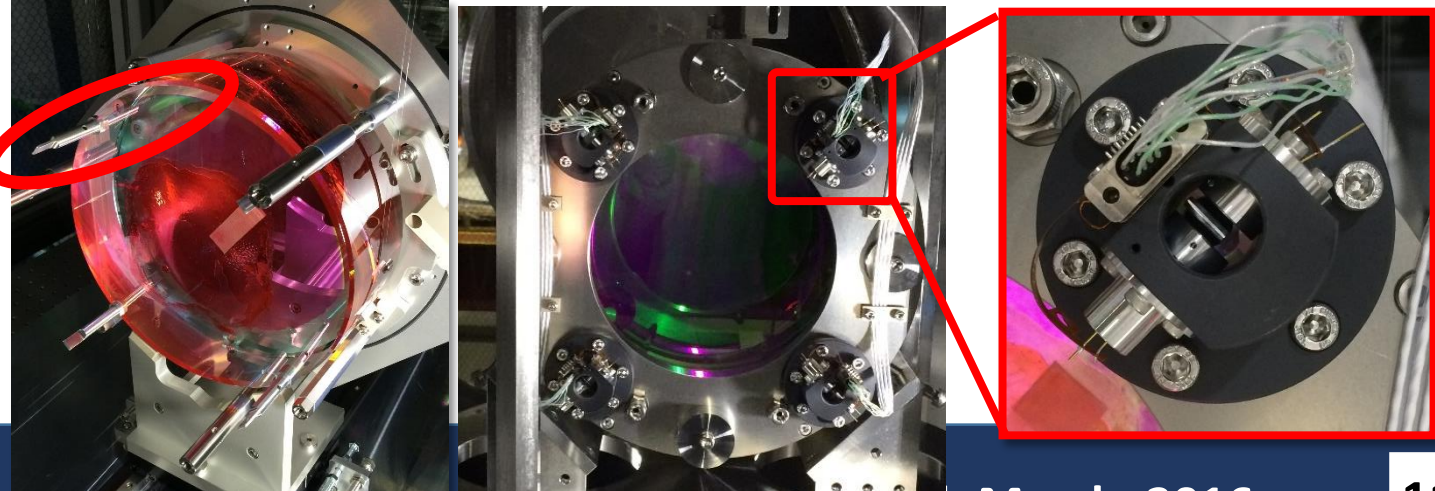

❖ PR3 防振装置 / センサ, アクチュエータ

光てこ (**Optical Lever**):

OSEM では見えない、地面に対する鏡の回転を測定するためのセンサ

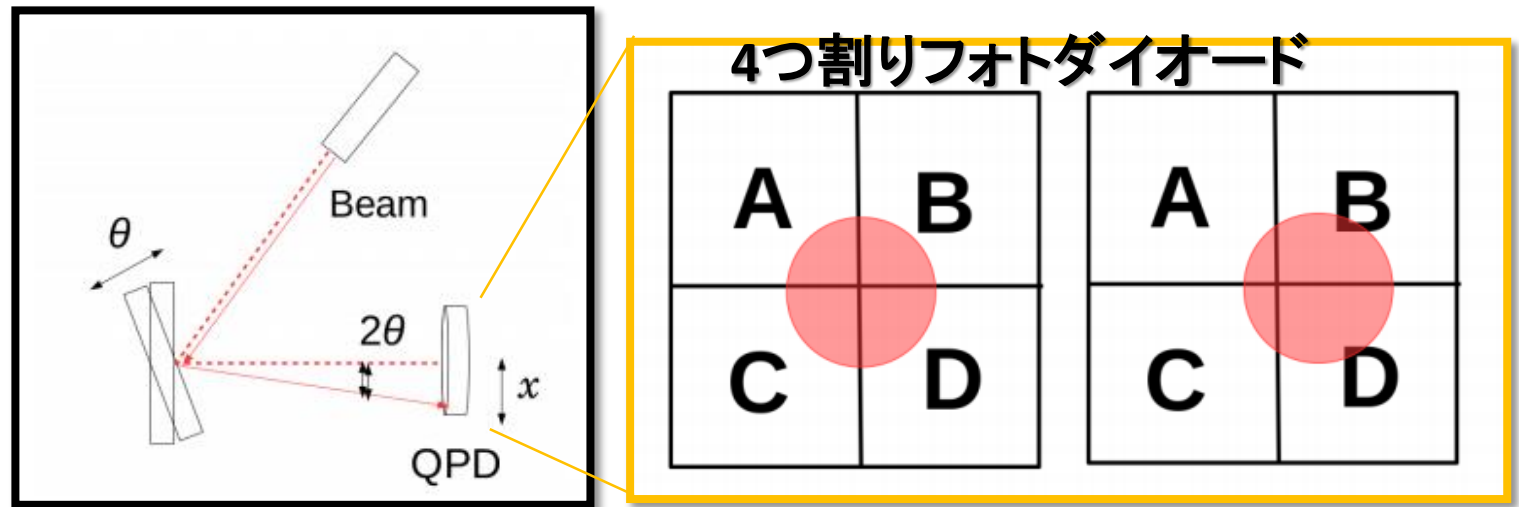
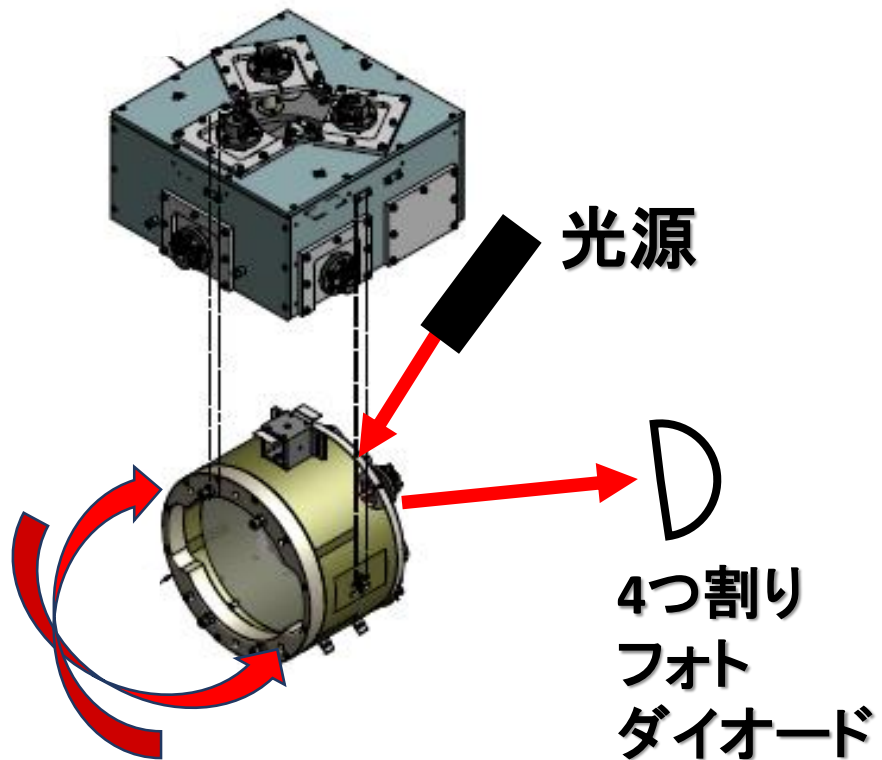

ビームスポットの変位 → 角度変化

Contents

□ はじめに / KAGRA

□ PR3 防振装置

◆ Installation (@ 神岡KAGRAサイト)

◆ 組み立て手順

◆ 干渉計での利用

□ まとめ

❖ Installation / 組み立て手順

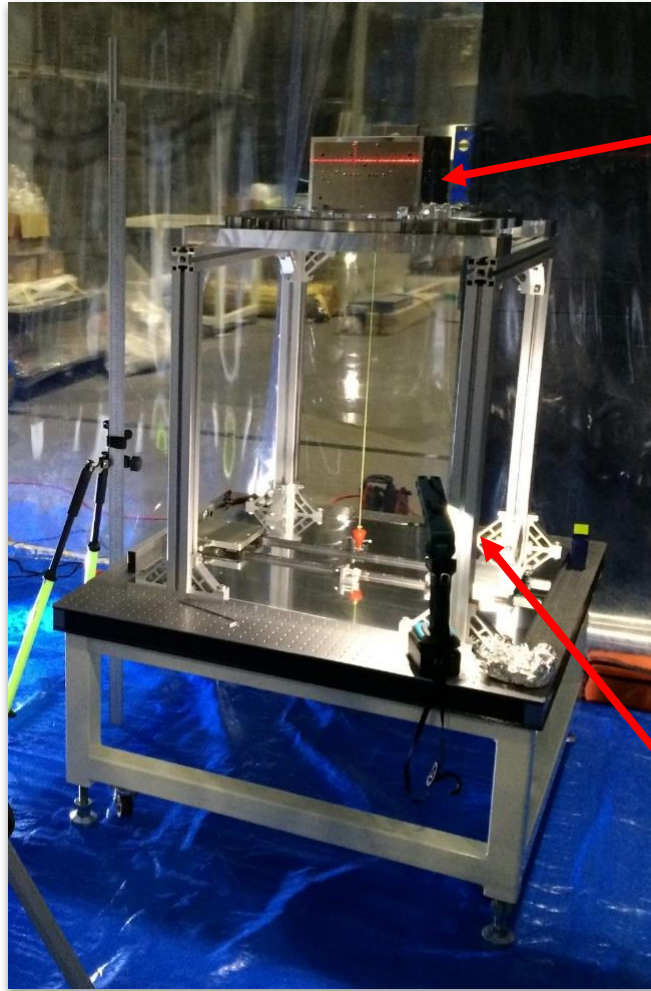

中段マス

鏡懸架用ジグ

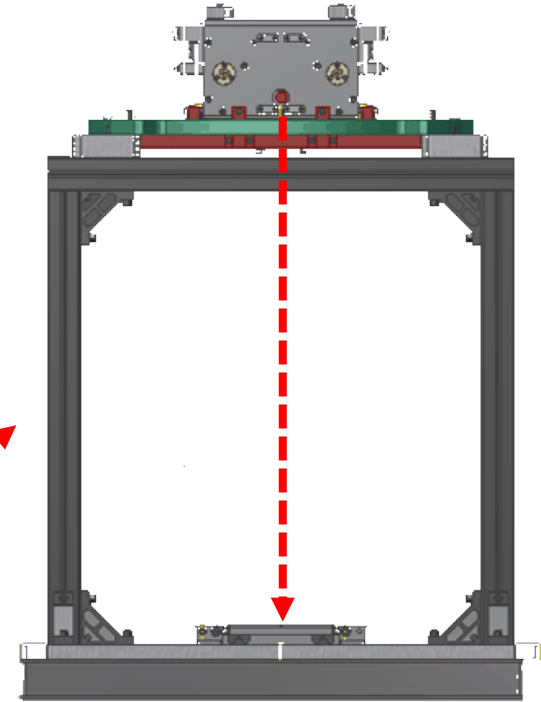

❖ Installation / 組み立て手順

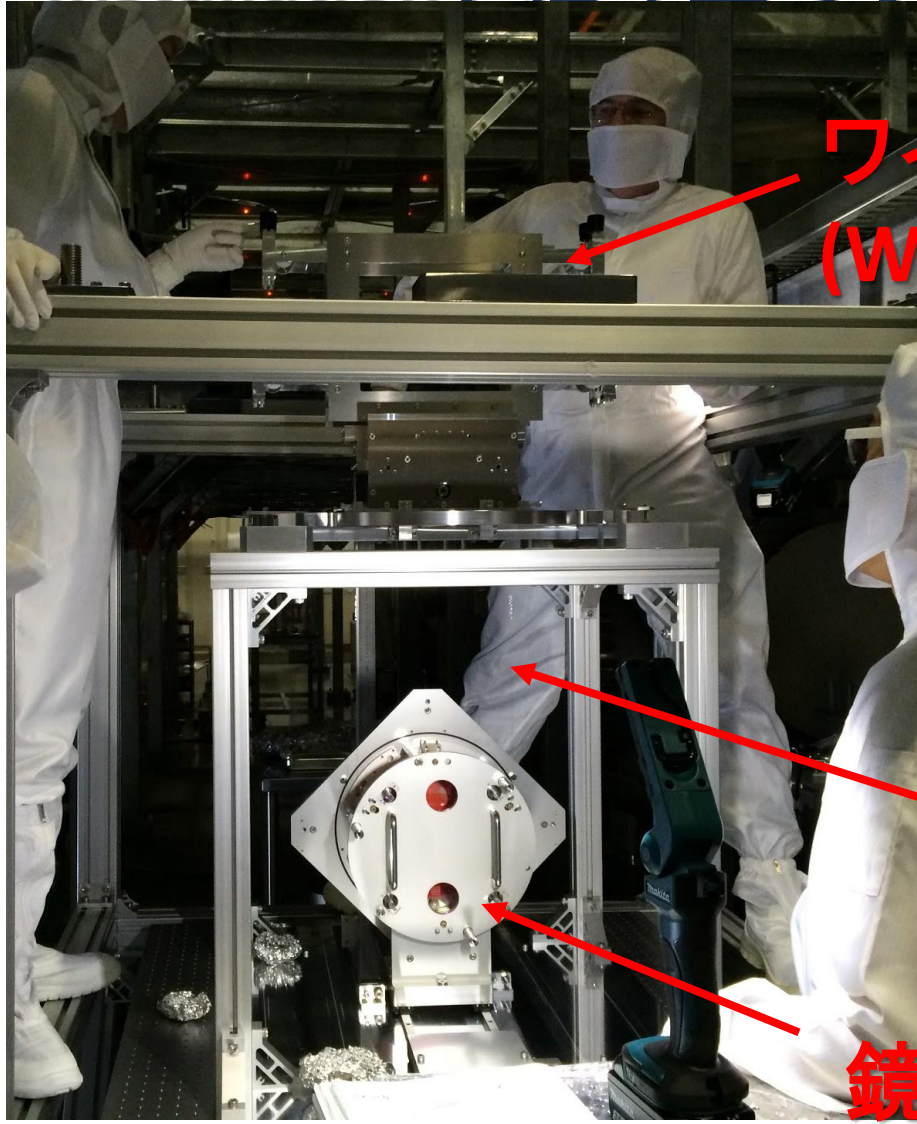

ワイヤ巻き付け用ジグ
(Winch)

ワイヤ

鏡保護・梱包用ジグ

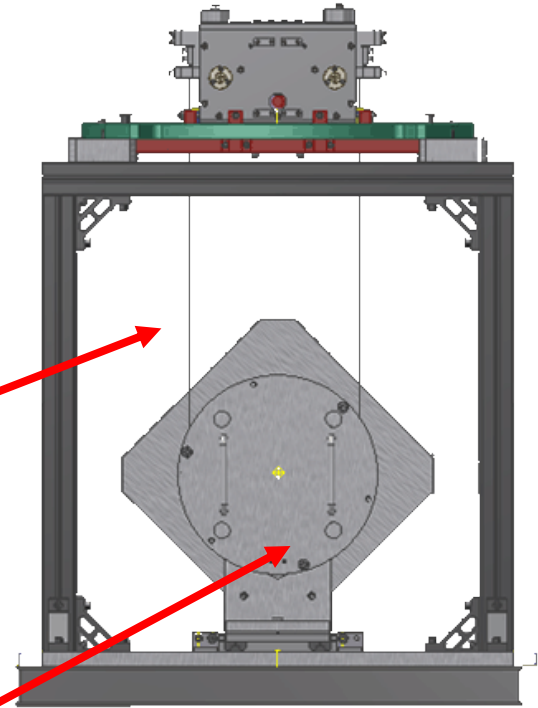

❖ Installation / 組み立て手順

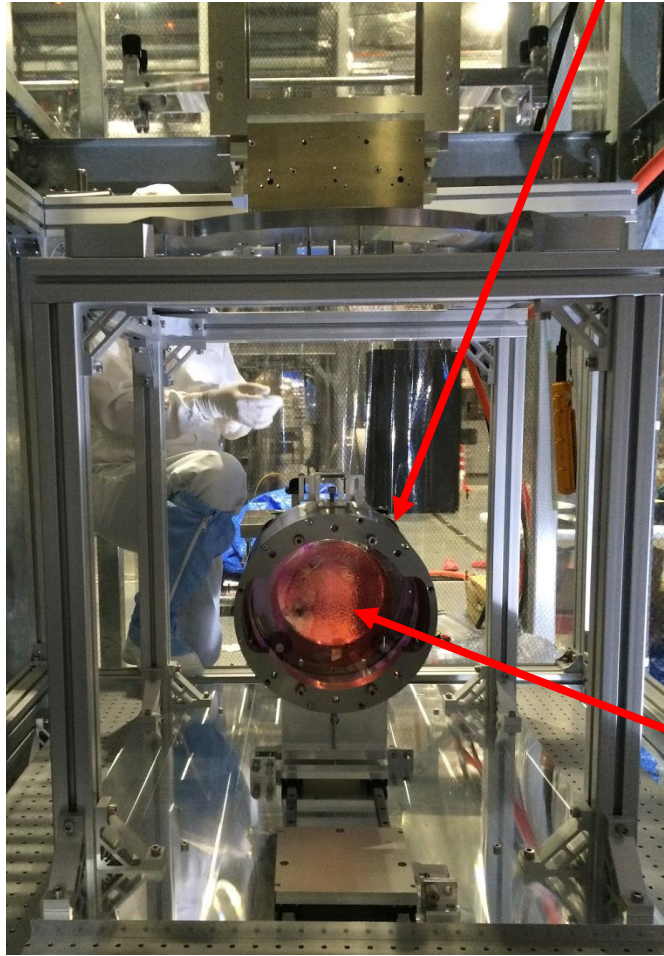
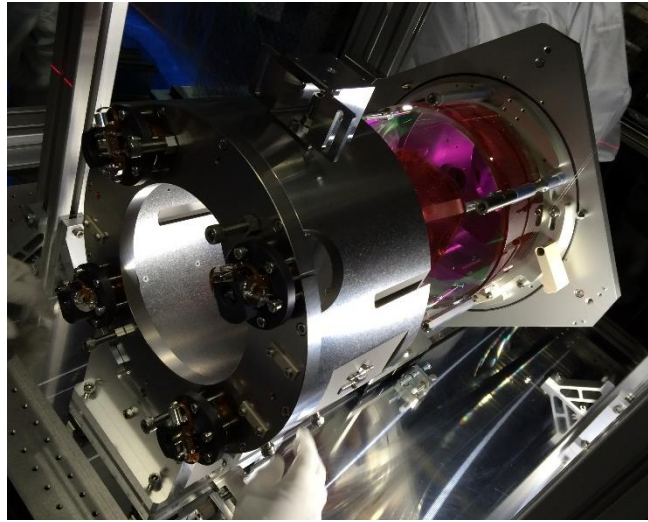

リコイルマス

鏡

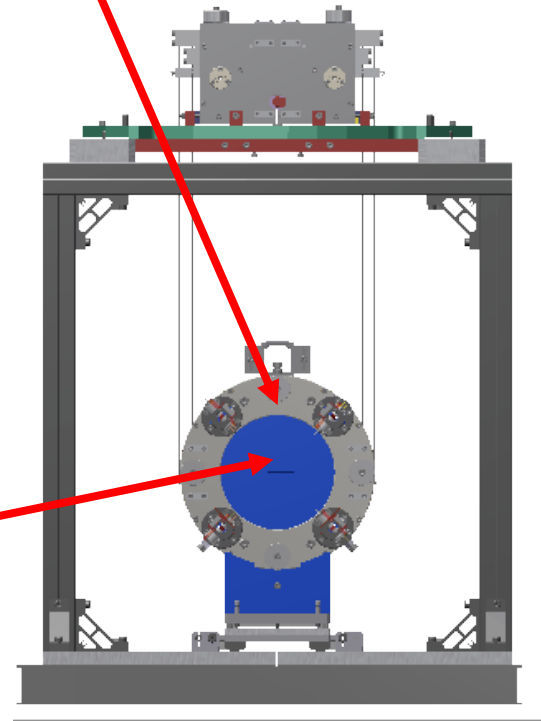

❖ Installation / 組み立て手順

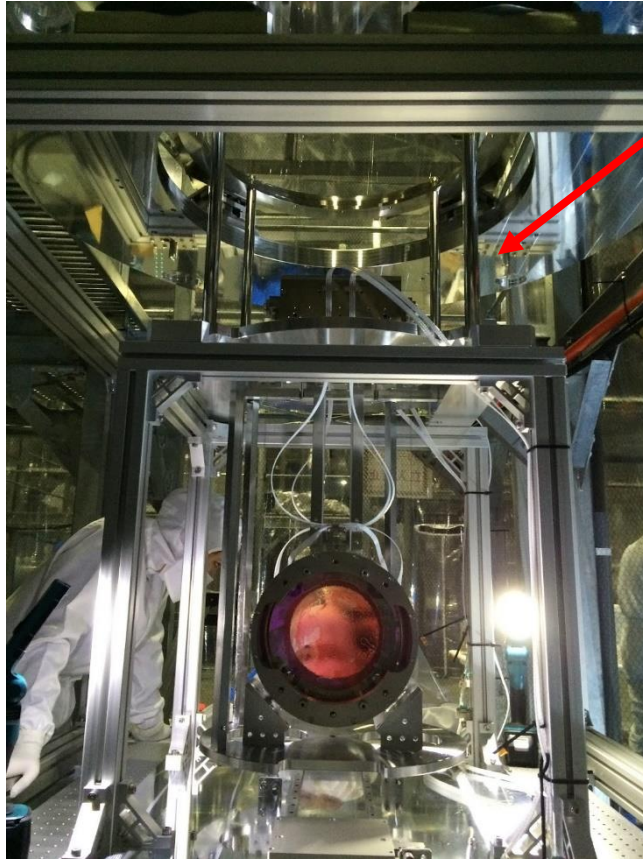

セキュリティ
フレーム

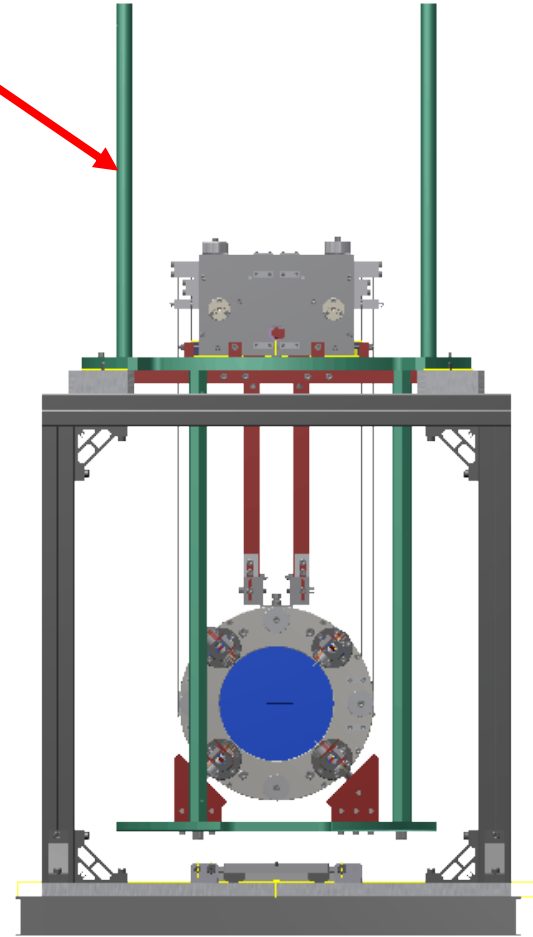

❖ Installation / 組み立て手順

GAS filter

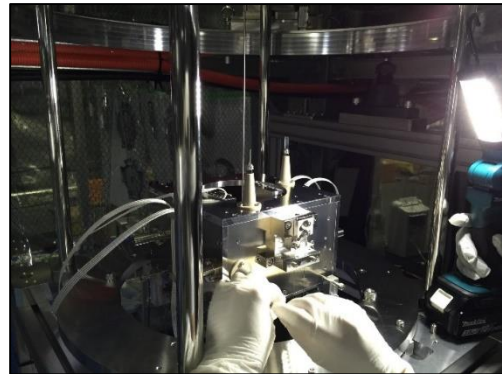
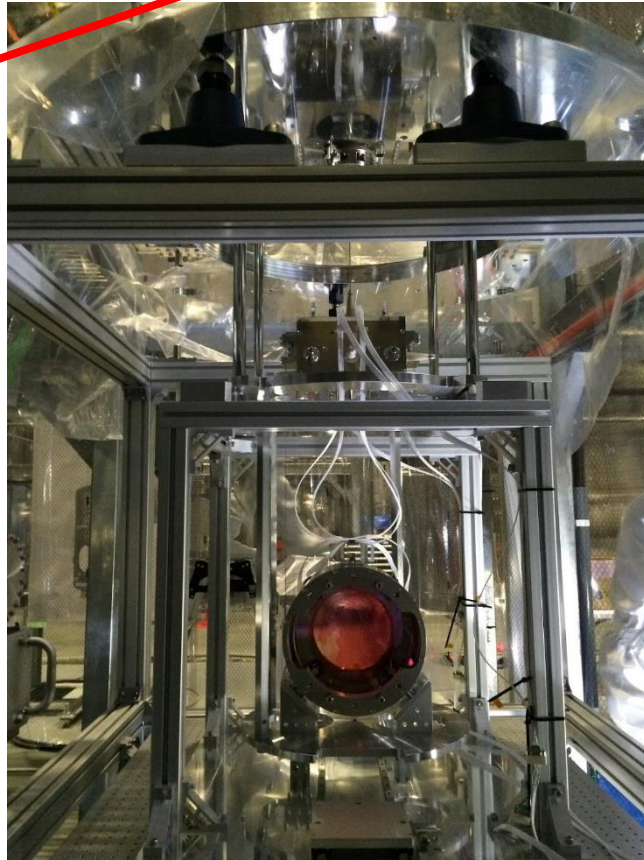
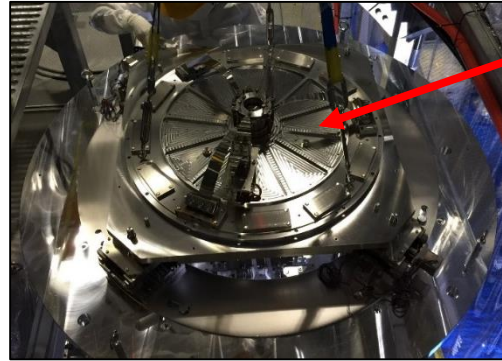
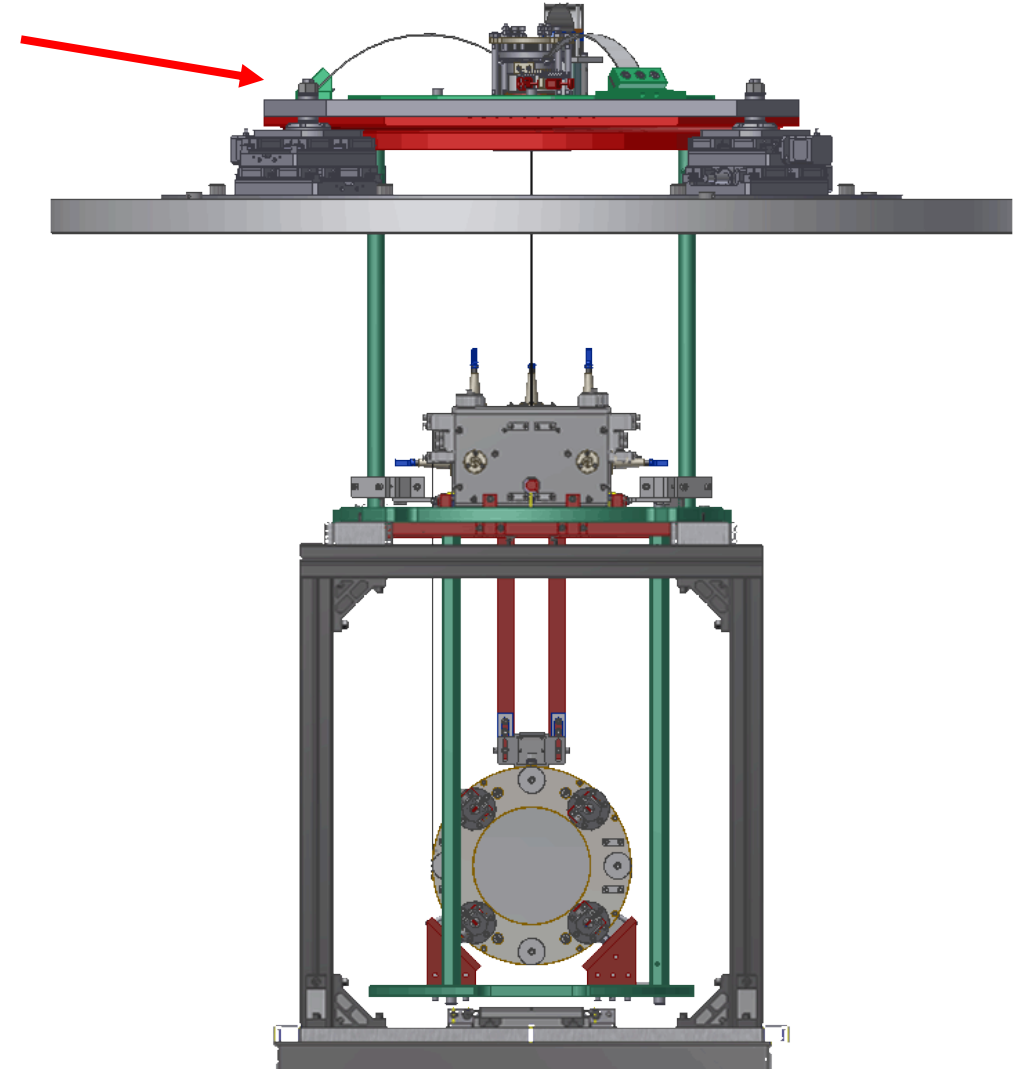

❖ Installation / 組み立て手順

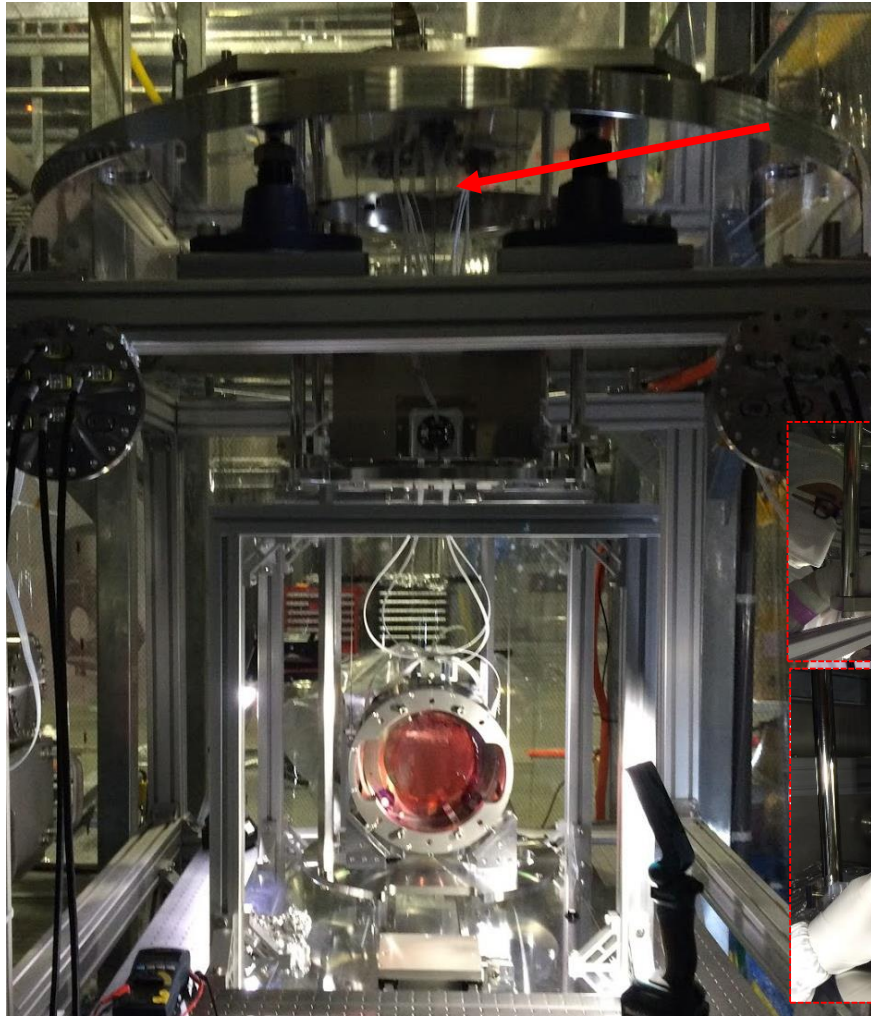

中段
リコイルマス

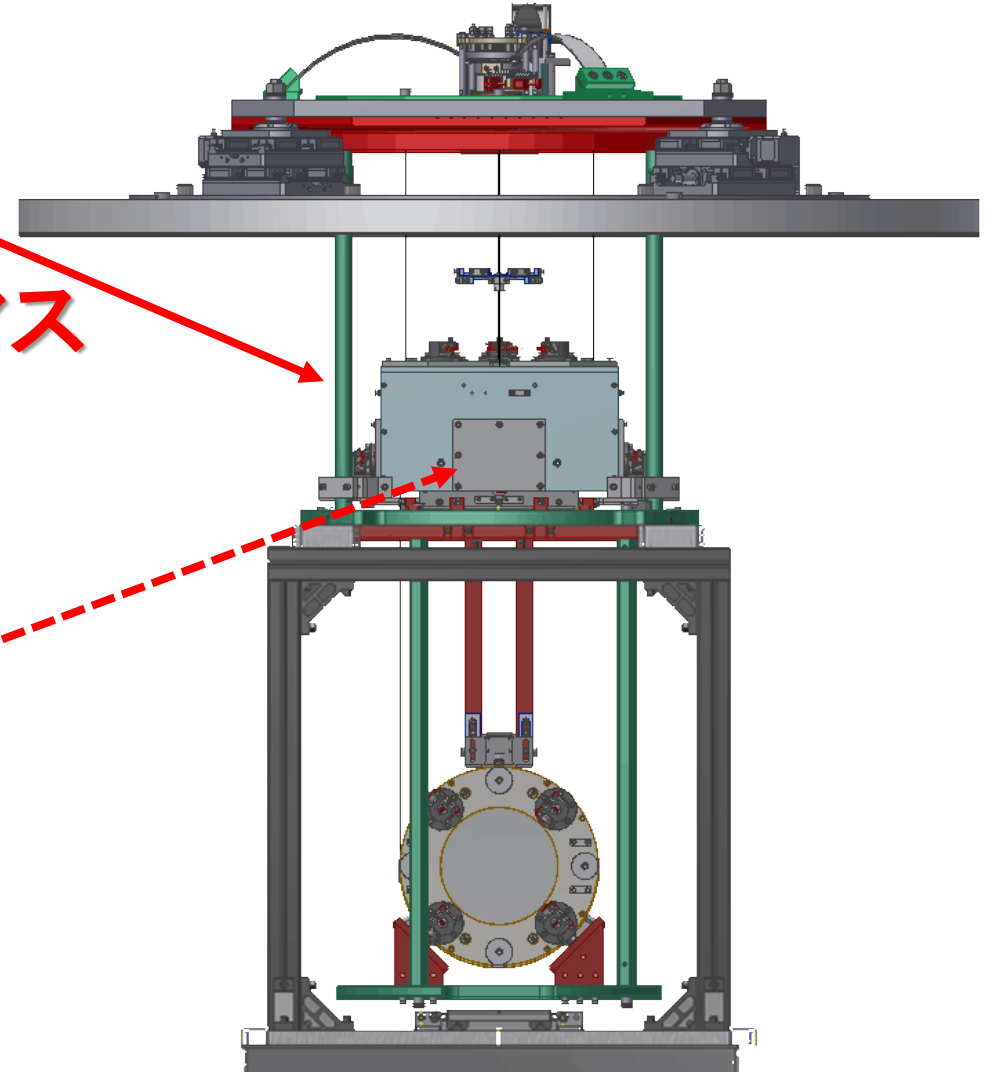
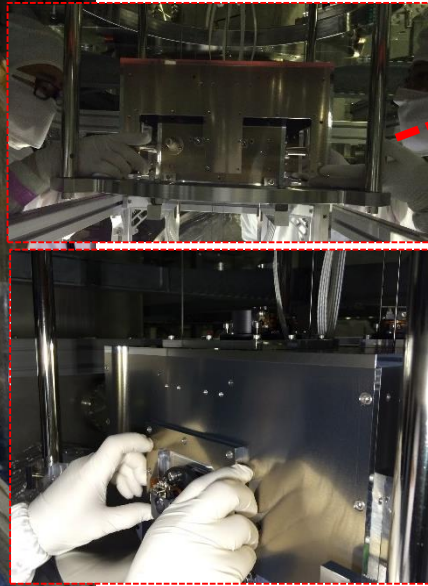

❖ Installation / 組み立て手順 真空槽

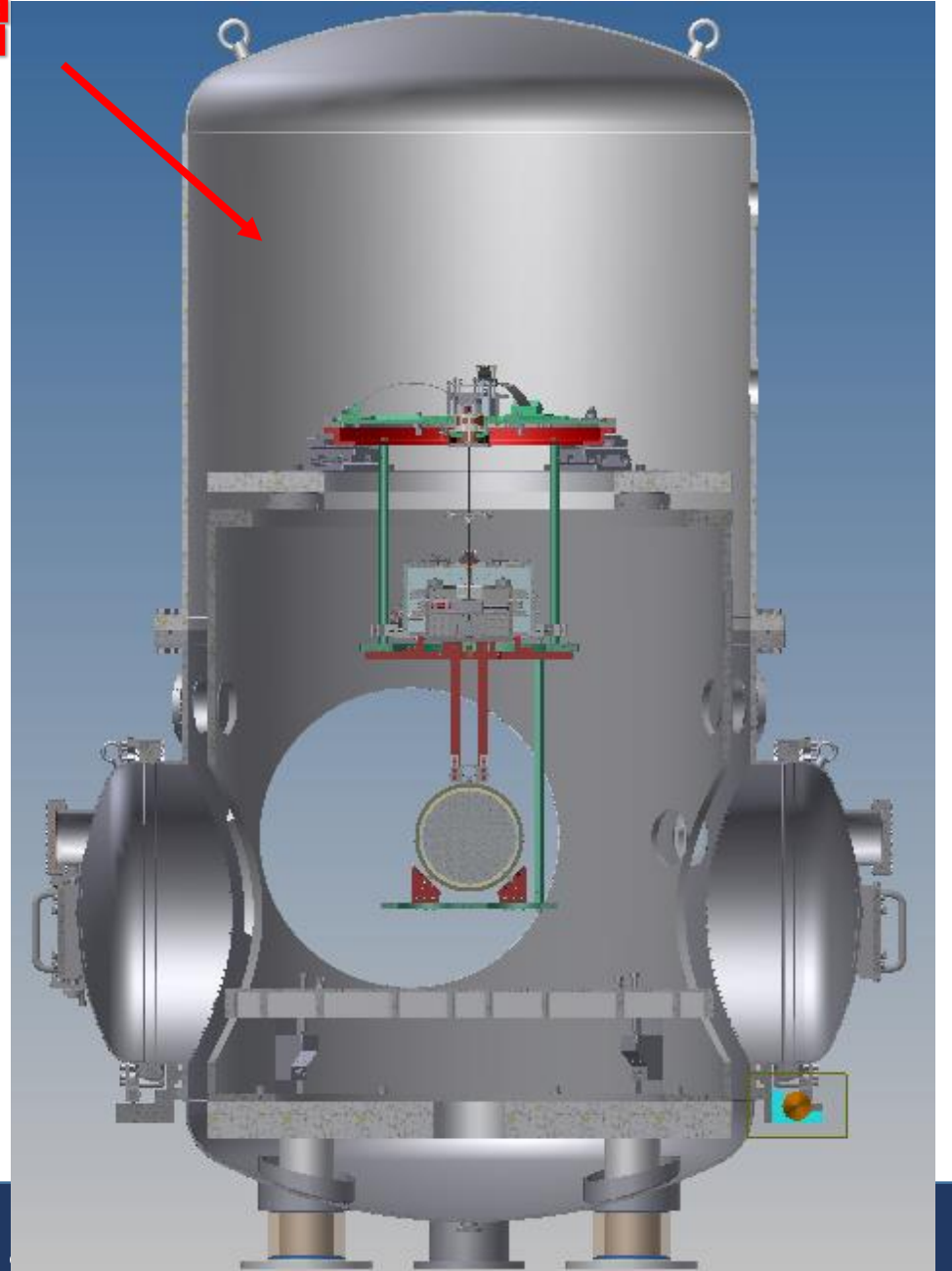
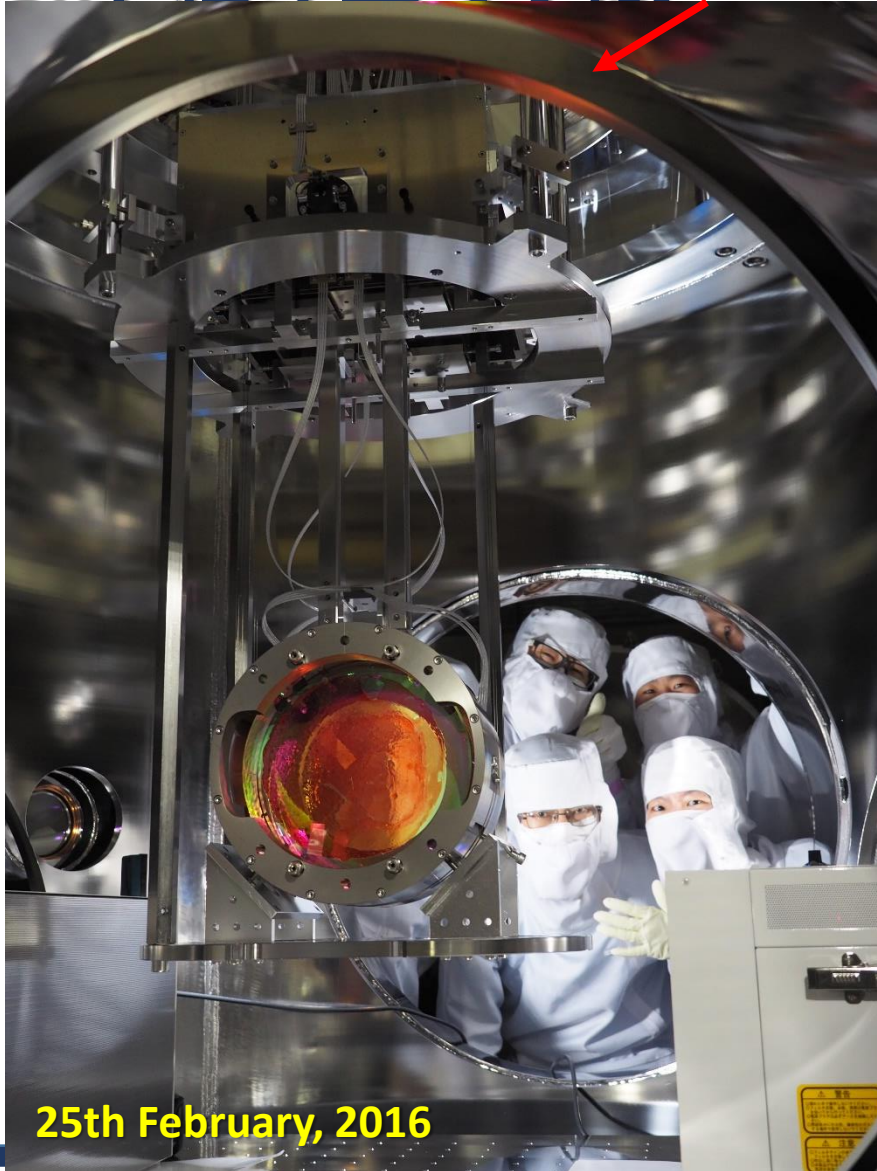

❖ Installation / 組み立て手順

* PR3 鏡とその防振装置のインストール中 →

力変位伝達関数
スペクトル
etc

を測定。

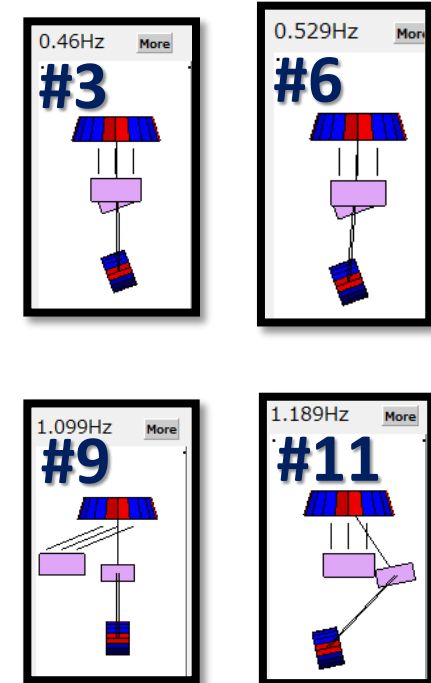
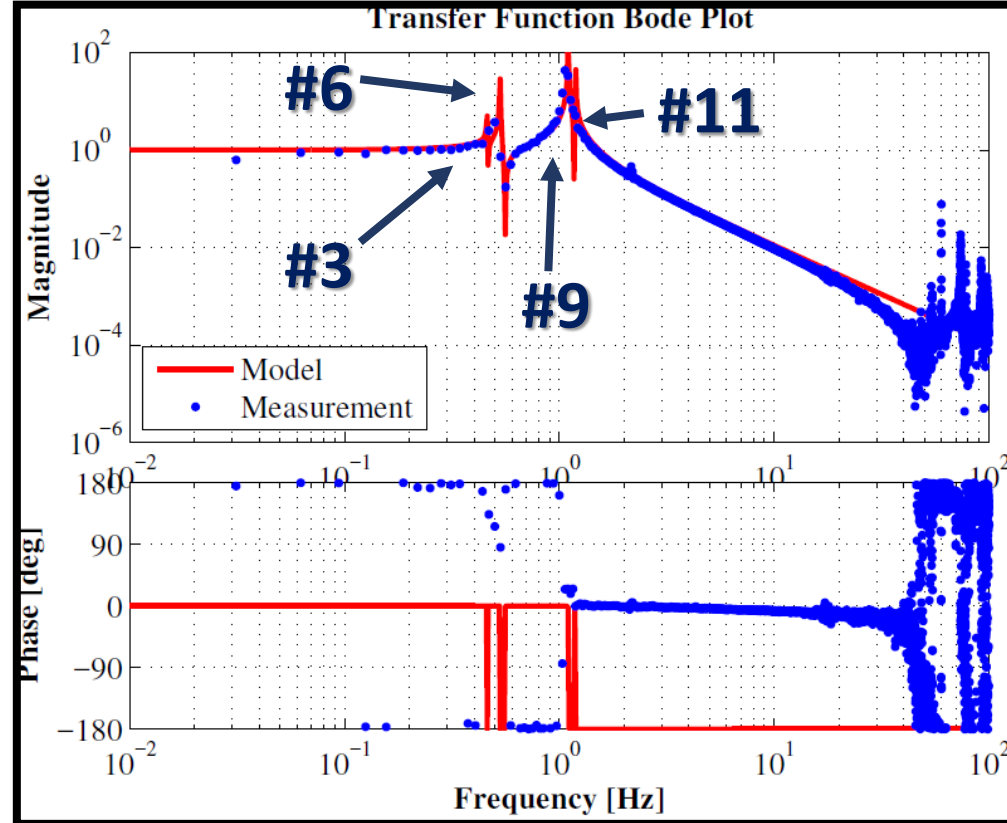
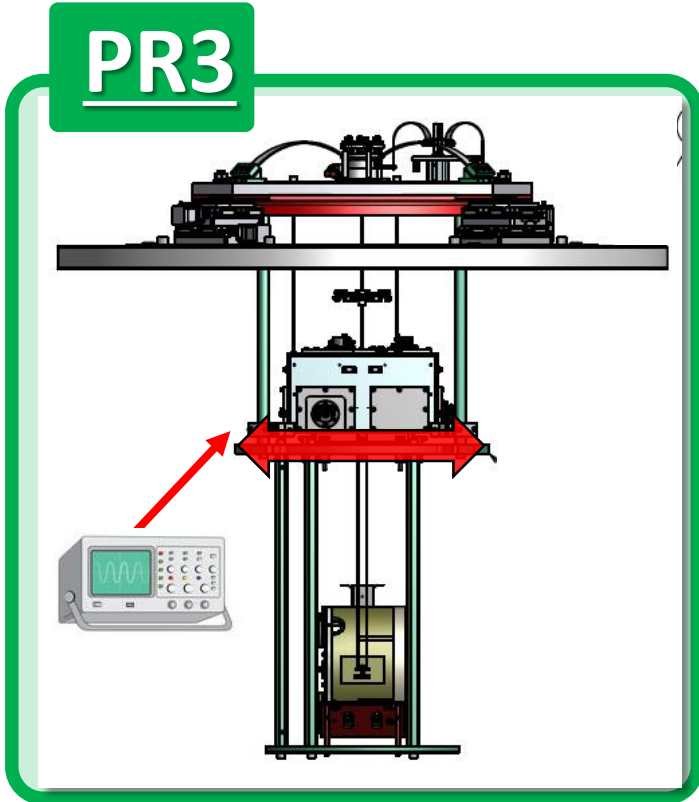

適切に懸架されているかの確認。

❖ Installation / 作業の反省

Installation 手順 → ペイロード・GAS (chain) の組立, 真空槽への吊入れの流れを一通り確認した。

より詳しくは：
PR3 installation procedure
JGW-T1604756

Type-Bp' install procedure and checklist

1. Set the frames
 - The hanging frame is at the center of the assembly frame.
 - The optical table is leveled.
 - The hanging frame is fixed on the optical table.
 - Sliders are properly set and move smoothly.
2. Set the IM EQ stops and IM
 - EQ stop is at the center of the hanging frame with alignment pins.
 - EQ stop plate is fixed by the clamps.
 - IM is at the center of the EQ stop.
 - The distance between the IM and the base of the hanging frame is correct.
 - The direction of the IM is OK.
3. Set the Sliders
 - The plumb is properly suspended from the center of the IM
 - The two positioning screws are fixed tightly at the right position.
 -
4. Preparation for the mirror hanging
 - The winch is set properly.
 - Wires (#0.2 piano wire) are cut and wiped with acetone.
 - OSEM flags are fine
 -
5. Hang the mirror
 - The base of the mirror box is properly set.
 - Some PEEK zigs at the upper side of the mirror are removed.
 - The piano wires are fixed in the grooves on the winch drums.
 - The piano wires are wired around more than once on the winch drums.
 - Wires are at the grooves on the wire breakers.
 - The wires around the mirror is parallel
 - The wires go through the grooves on the wire clamps.
 - Mirror is not dirty.
6. Align the mirror & Fix
 - The distance between the wire clamps on the IM and the wire breakers are the same at the both side. (587mm)
 - Optical lever is properly set. (The input beam is horizontal. The distance between the mirror surface and the fiber collimator is 1m.)
 - The mirror (including the FC tags) is not touching to anywhere.
 - The wires are properly fixed with wire clamping plates and the positioning plates.

❖ Installation / 作業の反省

* ただし細かな懸念事項・課題は残る。→ 手順修正の可能性有。

1) 鏡のOSEM flag が折れやすい。

- ① 鏡やリコイルマスをジグに固定(またはリリース)するときの確認事項の見直し
- ② OSEM (flag) の形状の見直し

2) 懸架系の Q 値が低い様子。

- 別途 Q 値測定の後、場合によっては要手順の見直し

3) Wire のテンションの未調査

- wire の Violin mode の測定

4) 真空槽内での作業

今回は真空槽の中に入って/身を乗り出して作業した。bKAGRAでの方法を要見直し

❖ Installation / 作業の反省

その他の KAGRA防振装置の Installation procedure の現状

PR3 installation procedure JGW-T1604756

- Type-Bp' install procedure and checklist
- Set the frames
 - The hanging frame is at the center of the assembly frame.
 - The optical table is leveled.
 - The hanging frame is fixed on the optical table.
 - Sliders are properly set and move smoothly.
 - Set the IM EQ stops and IM
 - EQ stop is at the center of the hanging frame with alignment pins.
 - EQ stop plate is fixed by the clamps.
 - IM is at the center of the EQ stop.
 - The distance between the IM and the base of the hanging frame is correct.
 - The direction of the IM is OK.
 - Set the Sliders
 - The plumb is properly suspended from the center of the IM
 - The two positioning screws are fixed tightly at the right position.
 - Preparation for the mirror hanging
 - The winch is set properly.
 - Wires (Φ0.2 piano wire) are cut and wiped with acetone.
 - OSEM flags are fine
 - Hang the mirror
 - The base of the mirror box is properly set.
 - Some PEEK zigs at the upper side of the mirror are removed.
 - The piano wires are fixed in the grooves on the winch drums.
 - The piano wires are wired around more than once on the winch drums.
 - Wires are at the grooves on the wire breakers.
 - The wires around the mirror is parallel.
 - The wires go through the grooves on the wire clamps.
 - Mirror is not dirty.
 - Align the mirror & Fix
 - The distance between the wire clamps on the IM and the wire breakers are the same at the both side. (587mm)
 - Optical lever is properly set. (The input beam is horizontal. The distance between the mirror surface and the fiber collimator is 1m.)
 - The mirror (including the FC tags) is not touching to anywhere.
 - The wires are properly fixed with wire clamping plates and the positioning plates.

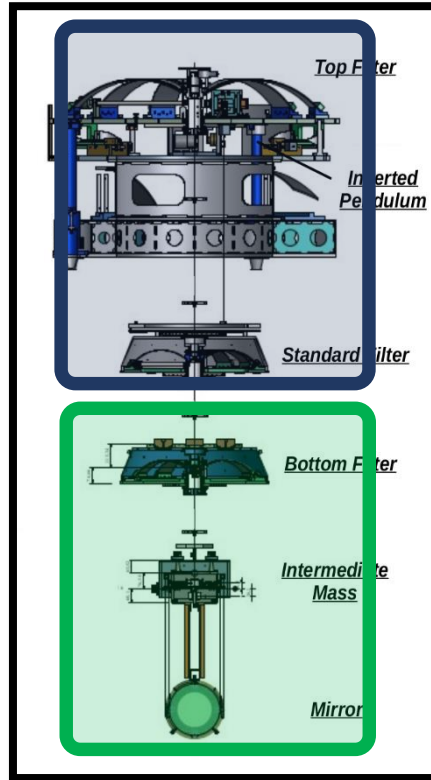

ここは
Prototypeでのみ
確認済み

ここまでは
ほぼ確立

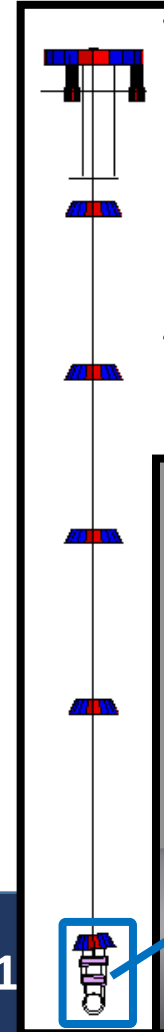

Payload
GAS chain
ともに未確認

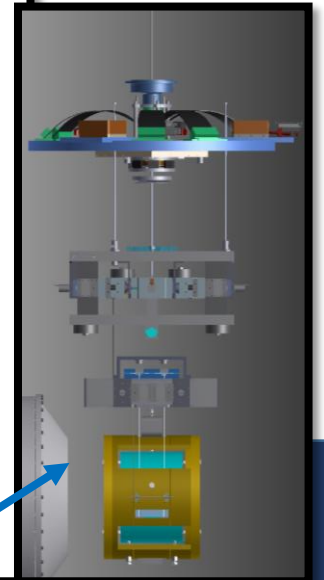

◆ 干渉計での利用

PR3 鏡 → 3 km 先に光を通すための調整用鏡

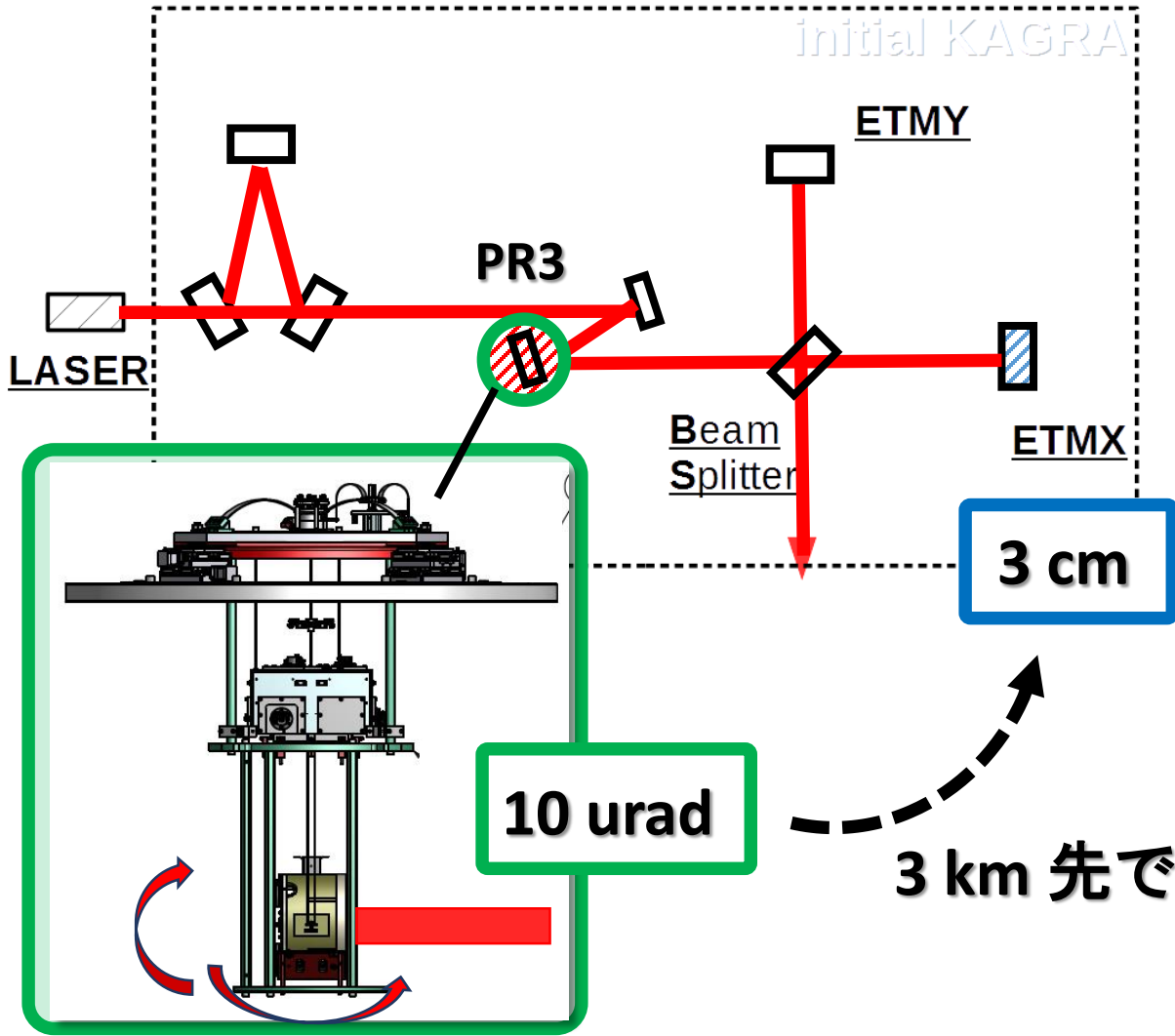

Traverser, 中段マス : 初期アライメント



中段マスのOSEM : 鏡の姿勢の微調整
+
ダンピング制御

PR3 鏡が揺れる (振り子の共振)
→ 3 km 先でビームスポットが大きく動く
→ PR3 鏡が揺れない状態が必要
→ 要PR3 のダンピング制御
(詳細 → 奥富 発表)

まとめ

- ❖ Installation 手順の確認を行った。
- ❖ iKAGRA干渉計のアライメント用の鏡(PR3鏡)とその防振装置を神岡KAGRAサイトにて組立てた。(2.25, 2016 に完了)
- ❖ その性能の確認と制御を実施。(→ 奥富 発表)

Next step

- ❖ PR3防振装置の評価、修正
- ❖ Installation 手順の確立

Thank you for your attention.

Back up

◆はじめに：懸架装置

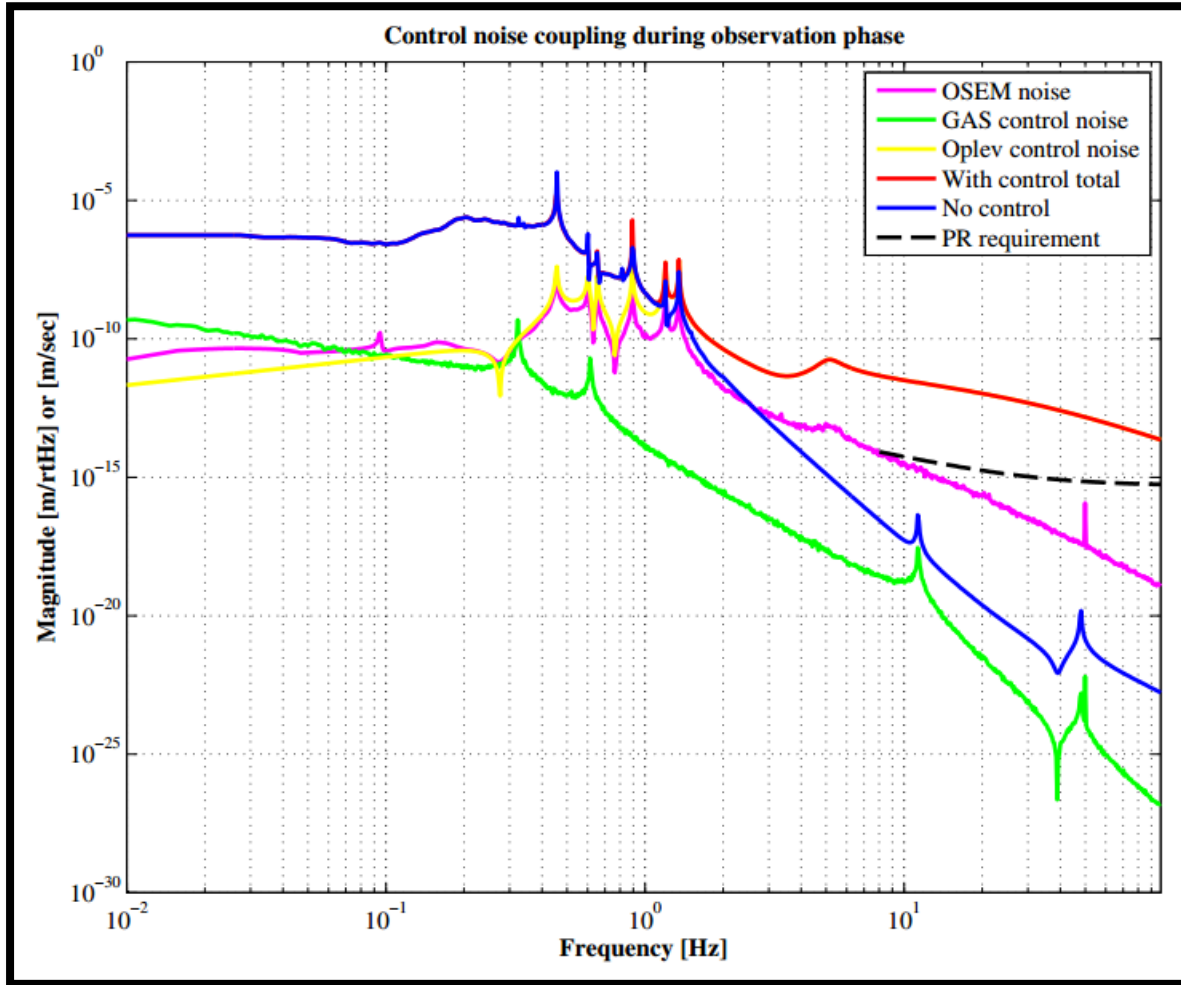

Displacement noise and Sensor noise couplings of the TypeBp SAS

① Measurement vs. SUMCON : TypeBpp_iKAGRA

Model Construction Calculation Result Export Model

Model Basic Information

Degrees of Freedom:
18 State Variables
6 Input Variables
1 Float Variables

Ground Position:
xF2 → 0. yF2 → 0. zF2 → 0. pitchF2 → 0. yawF2 → 0. rollF2 → 0.

Equilibrium Point:
xIR → 0. yIR → -0.5026 zIR → 0. pitchIR → 0. yawIR → 0. rollIR → 0.
xIM → 0. yIM → -0.5519 zIM → 0. pitchIM → 0. yawIM → 0. rollIM → 0.
xRM → 0. yRM → -1.139 zRM → 0. pitchRM → 0. yawRM → 0. rollRM → 0.
hGAS2 → 0.0269

TypeBpp_iKAGRA

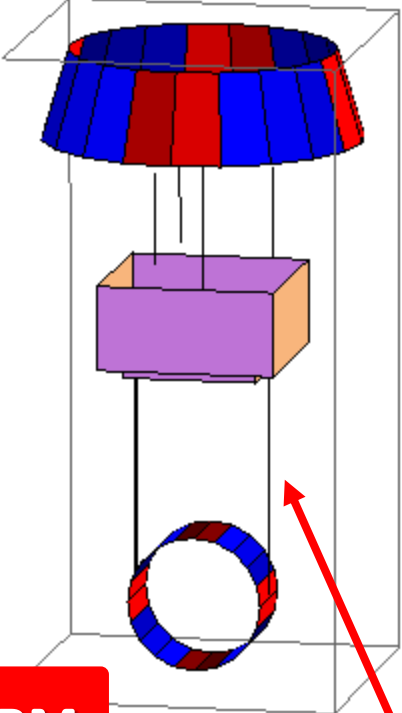

The PR TM fixed to the RM

RM is suspended by 4 wires

Eigen Mode List

Eigen Mode Shape

TypeBpp for iKAGRA (real configuration)

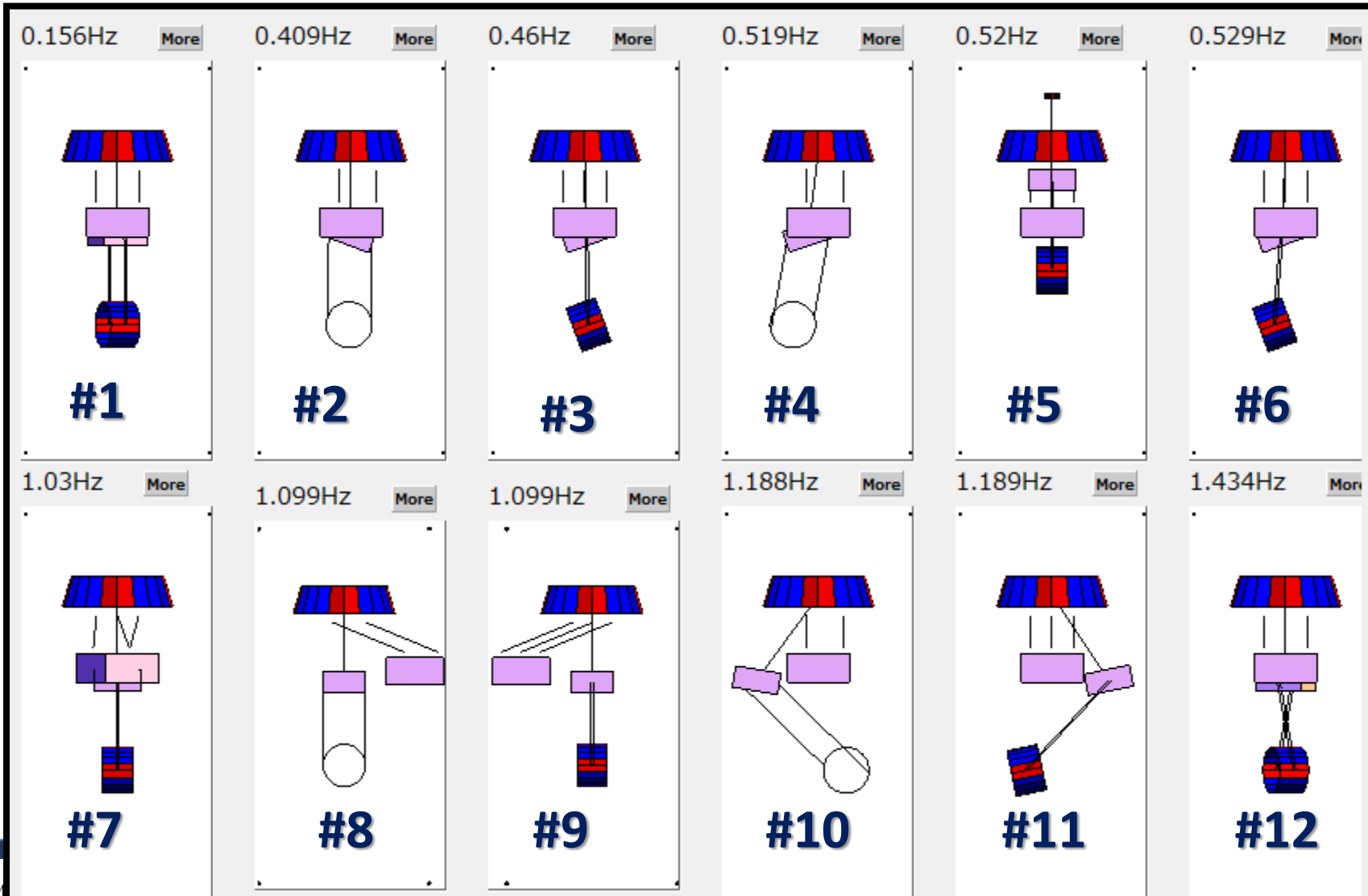

Eigen Mode Shape

TypeBpp for iKAGRA (real configuration)

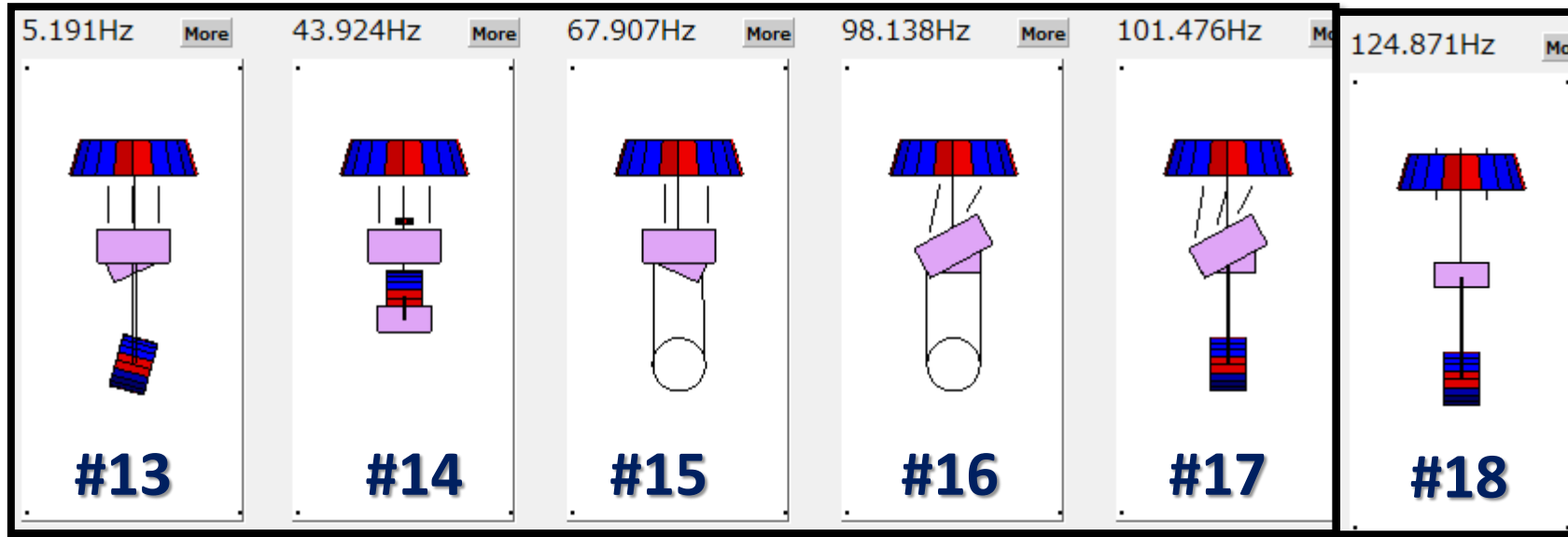

From 160301 measurement:

Force Transfer Functions with No Ctrl

(, which can be measured and actuated.)

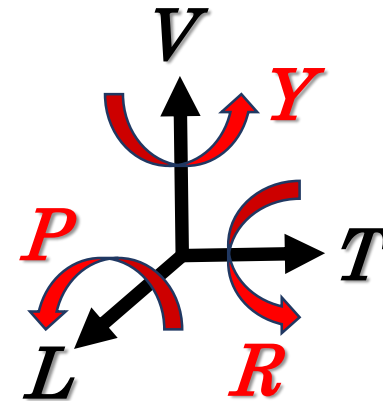
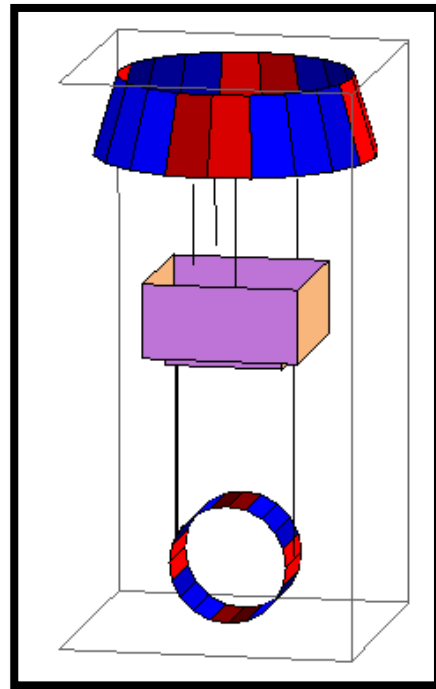

Force Transfer Function

TypeBpp for iKAGRA (real configuration)

LVDT_VBF / actVBF

#5 : GAS

#14 : VRM

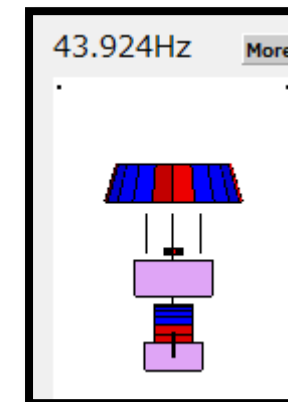
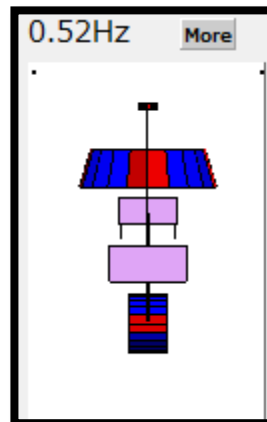
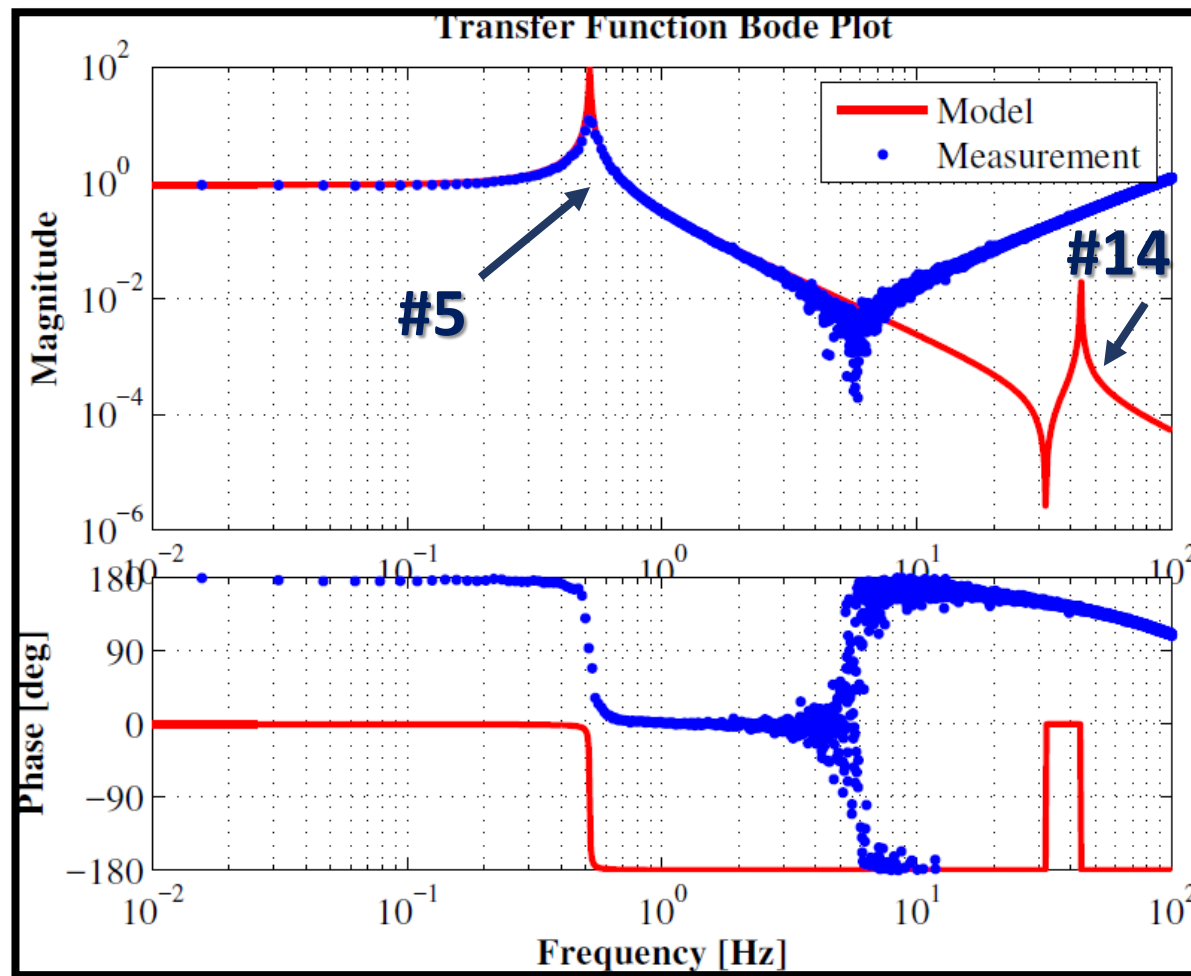

Force Transfer Function

TypeBpp for iKAGRA (real configuration)

OSEM_LIM / actLIM

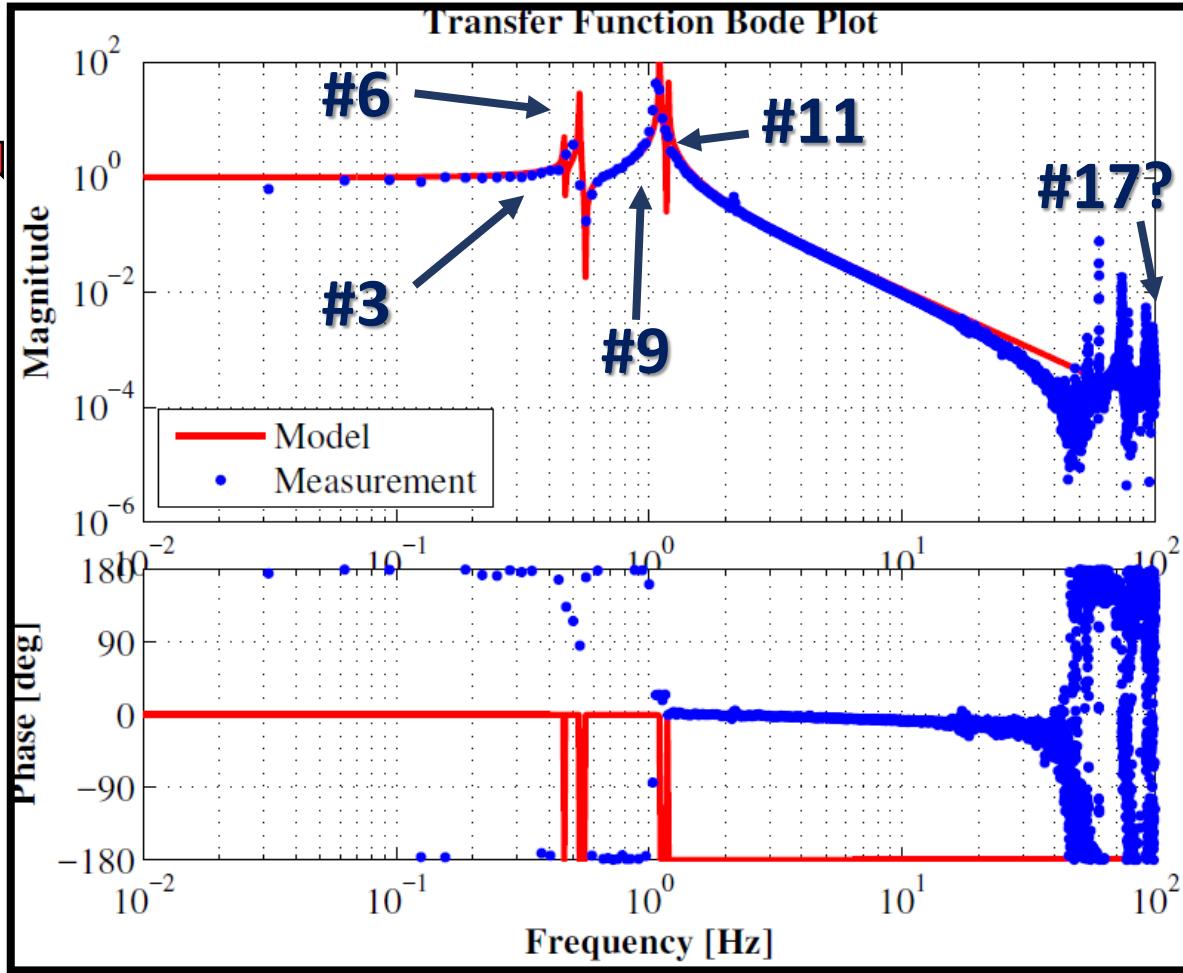

#3 : PIM /PRM

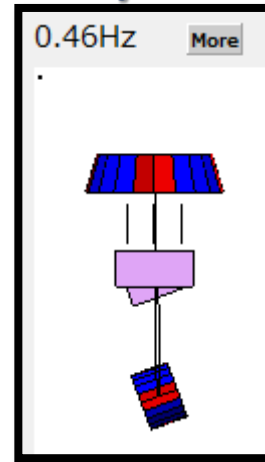

#6 : PIM /PRM

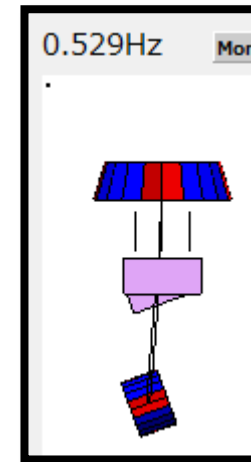

#9 : LIR

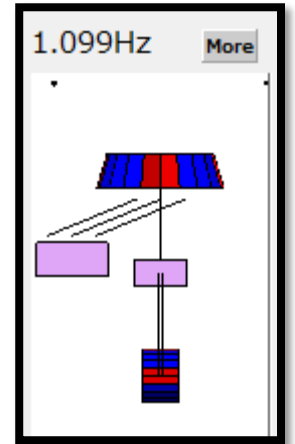

#11 : LIM

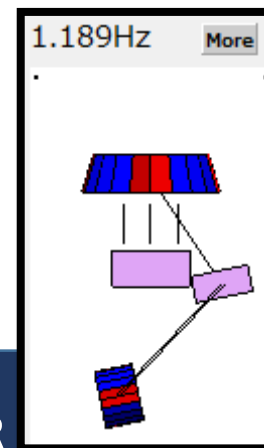

#17 : RIR ?

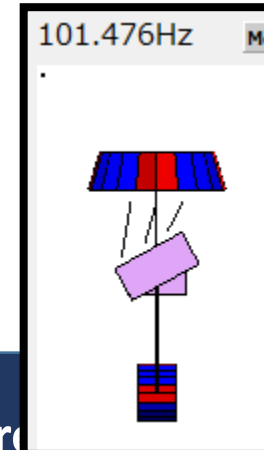

Force Transfer Function

TypeBpp for iKAGRA (real configuration)

OSEM_TIM / actTIM

#2 : RIM
/RRM

#4 : RIM
/RRM

#8 : TIR

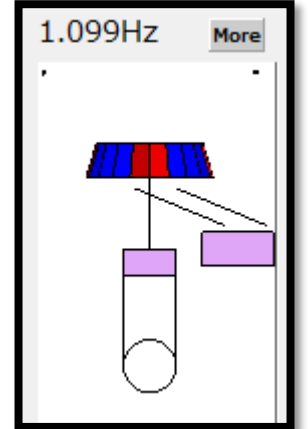
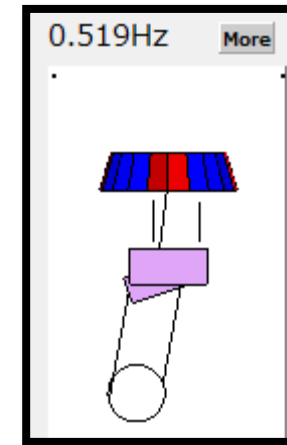
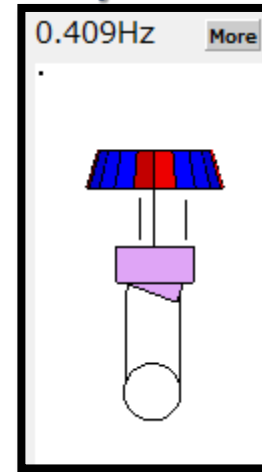
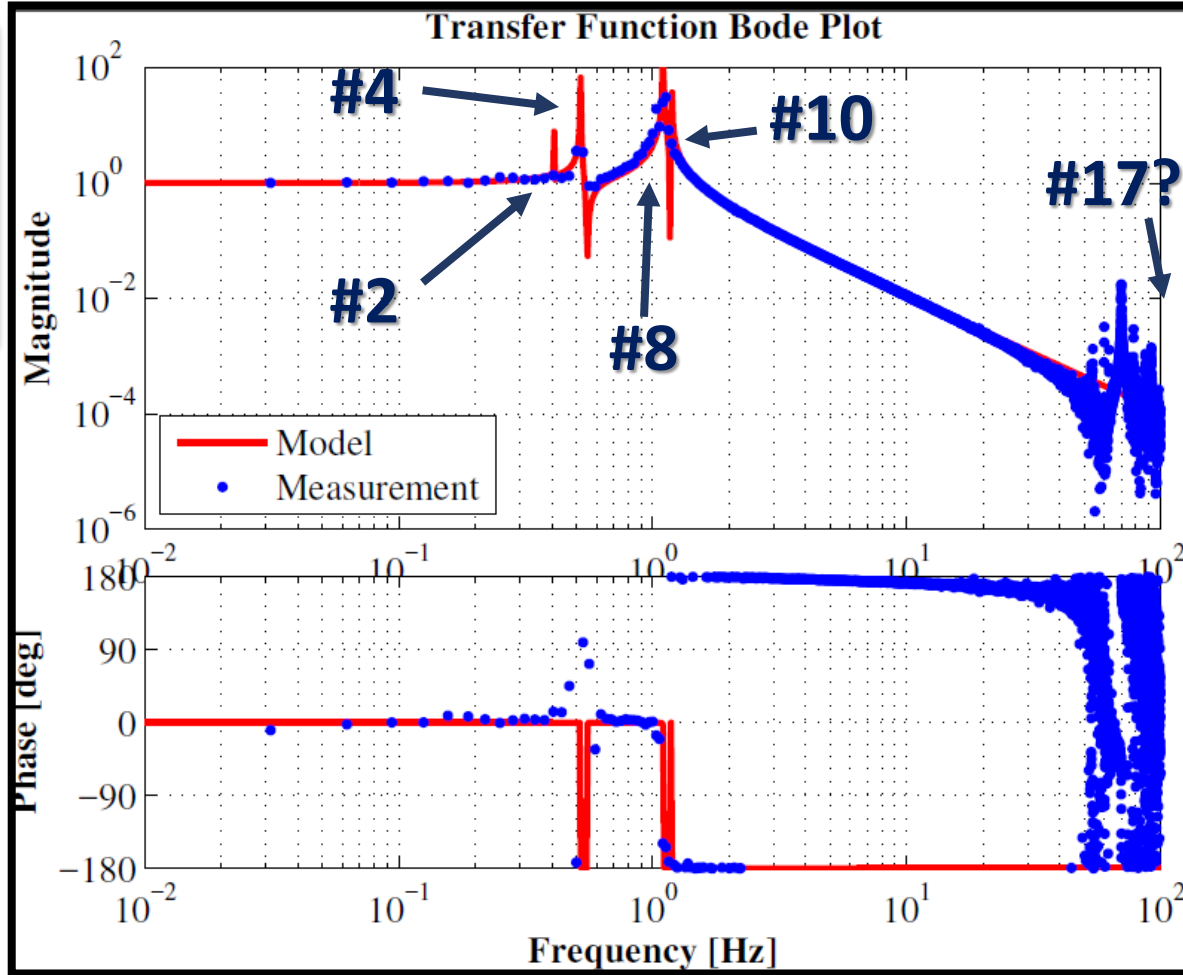
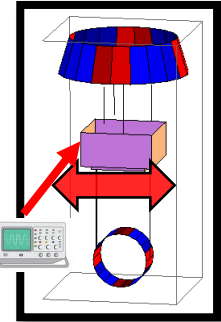

#10 : TIM

#17 : RIR ?

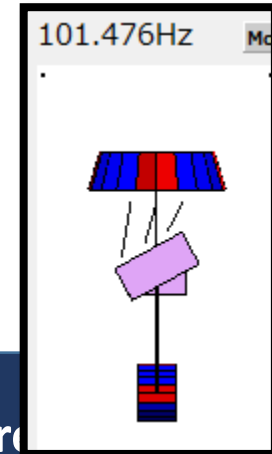
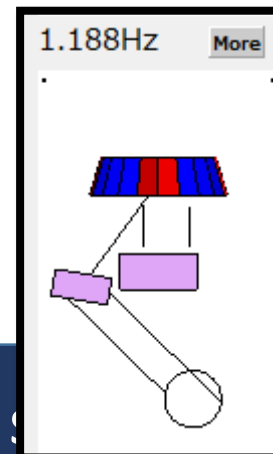

Force Transfer Function

TypeBpp for iKAGRA (real configuration)

OSEM_VIM / actVIM

#5 : GAS

#14 : VRM

#18 : VIR

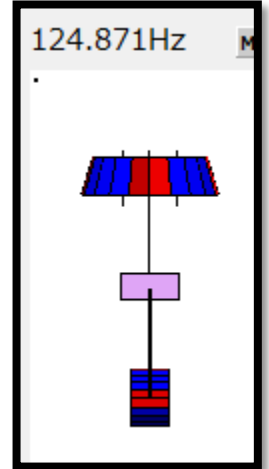
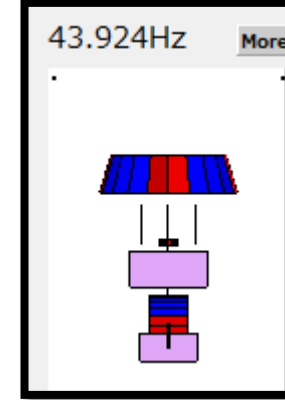
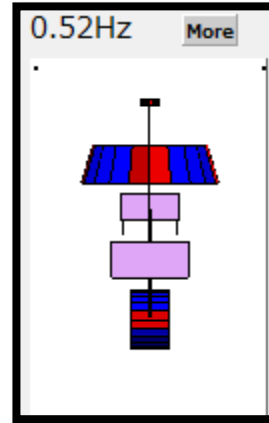
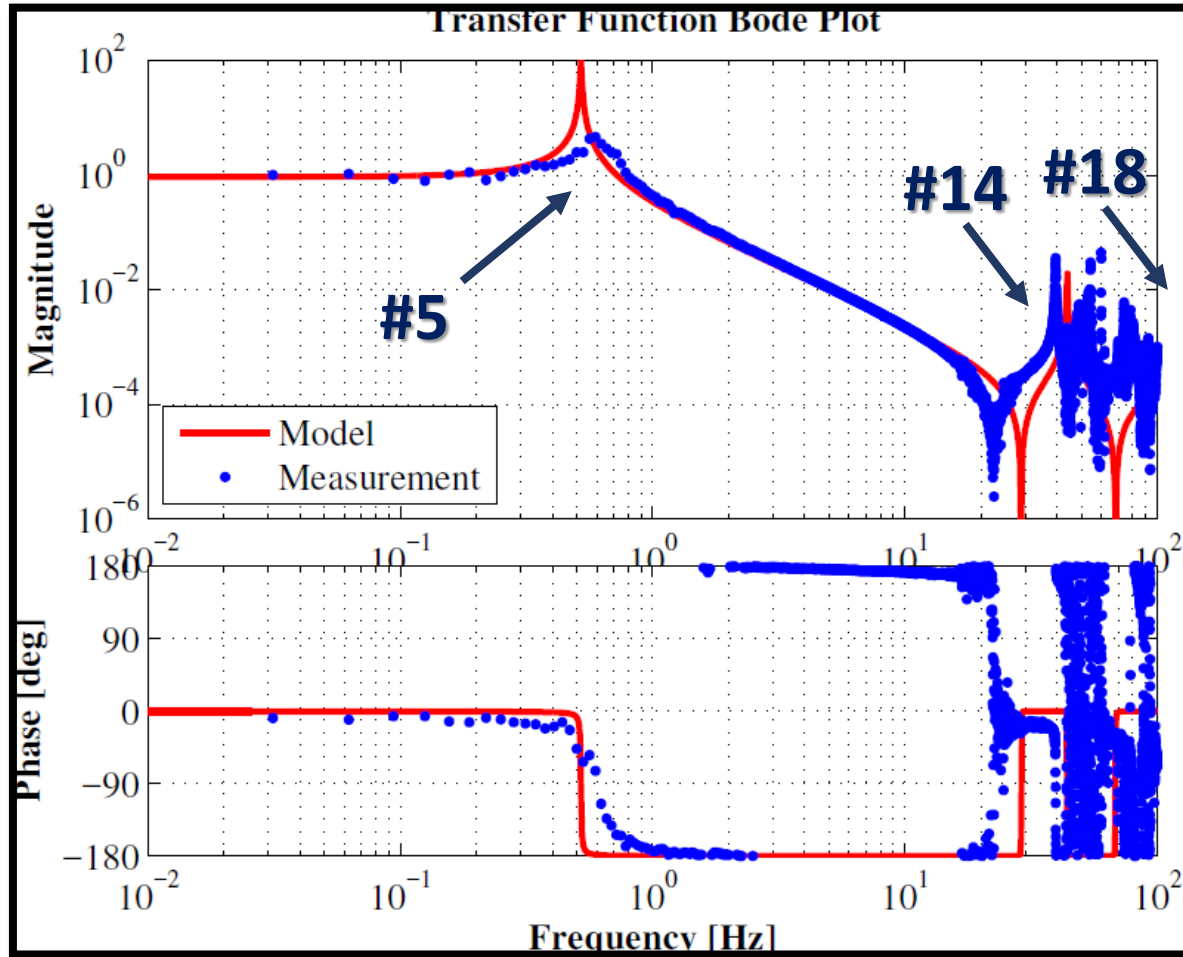

Force Transfer Function TypeBp with IP

OSEM_RIM / actRIM

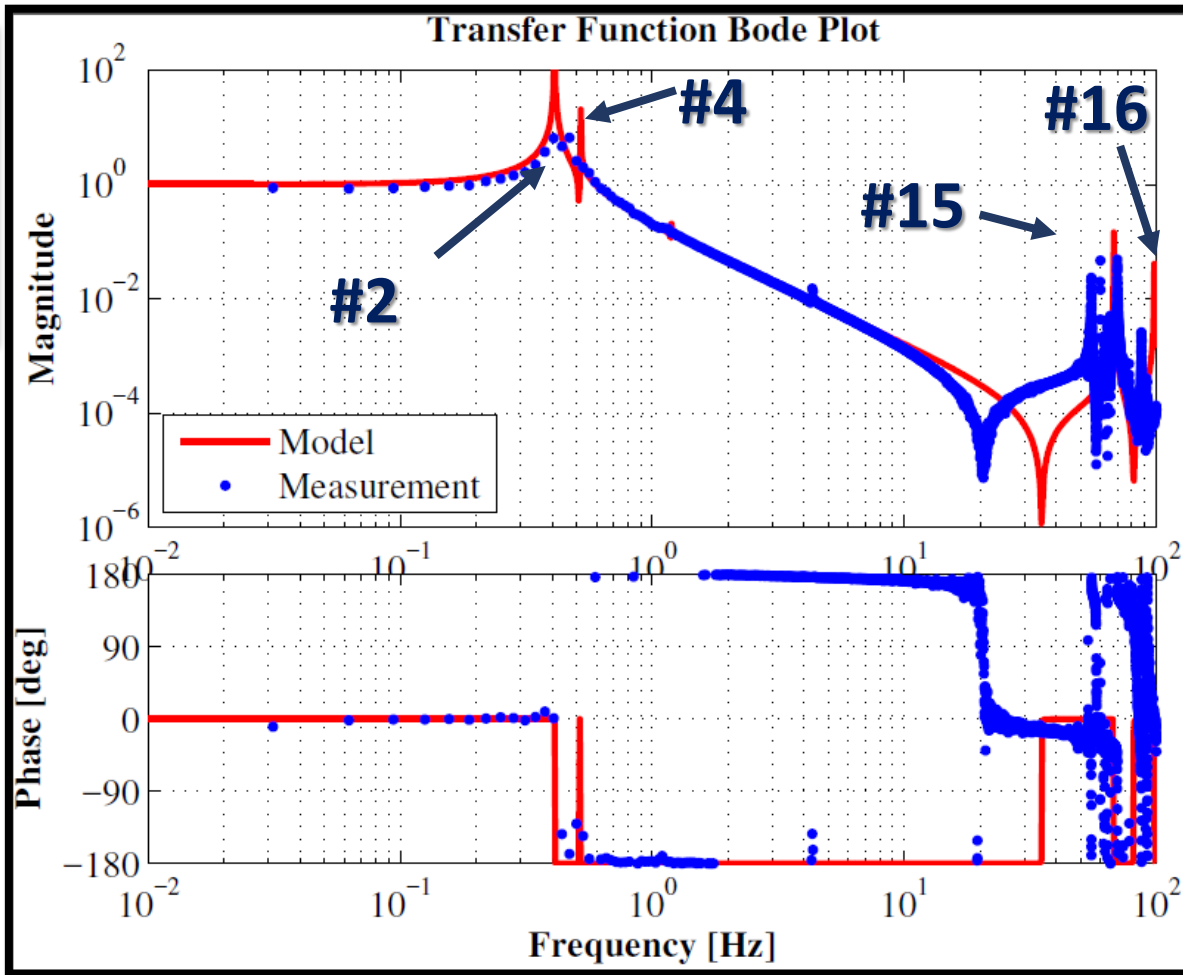

#2 : RIM
/RRM

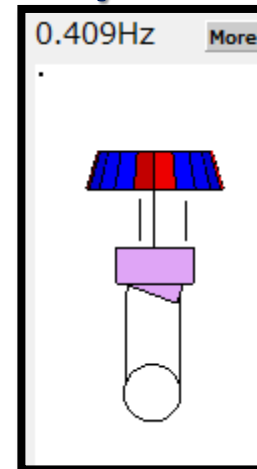

#4 : RIM
/RRM

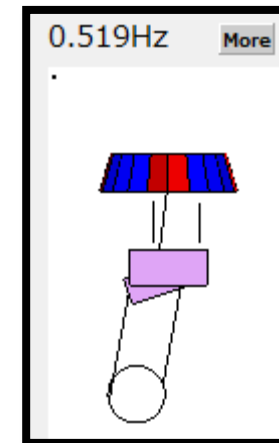

#15 : RIM

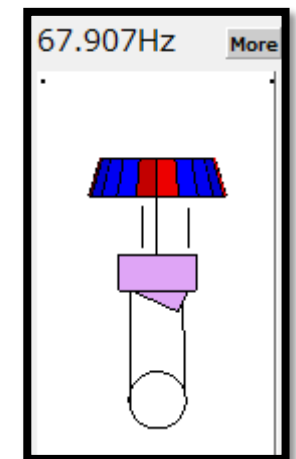

#16 : RIR

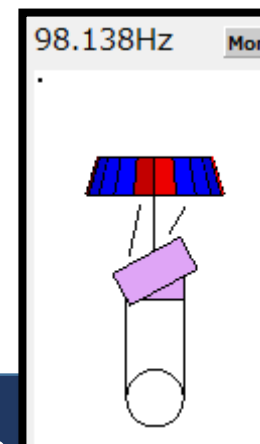

Force Transfer Function

TypeBpp for iKAGRA (real configuration)

OSEM_PIM / actPIM

Transfer Function Bode Plot

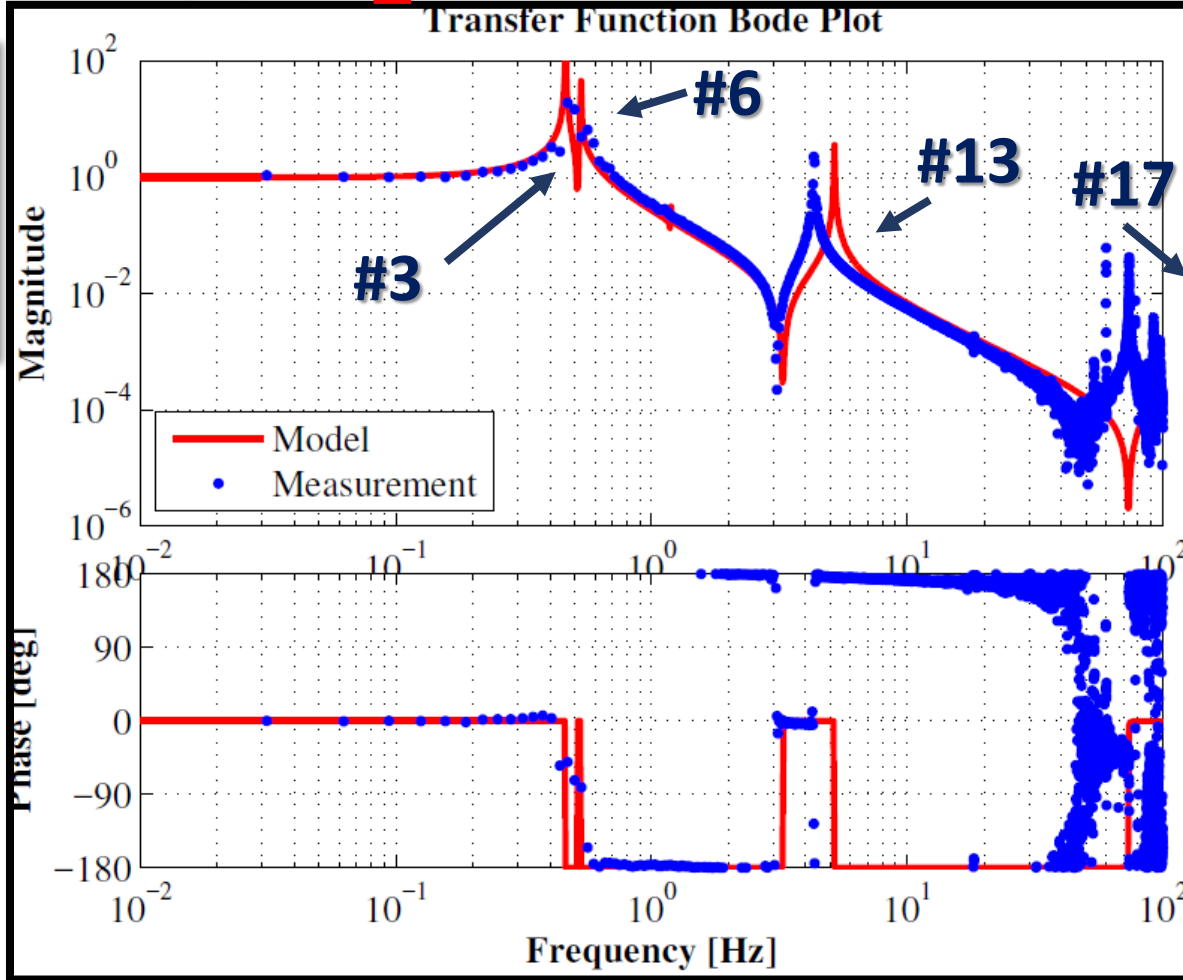

#3 : PIM
/PRM

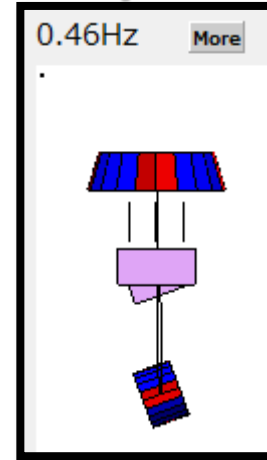

#6 : PIM
/PRM

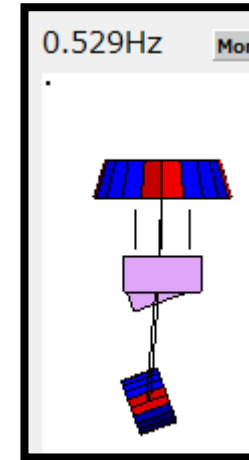

#13 : PIM
/PRM

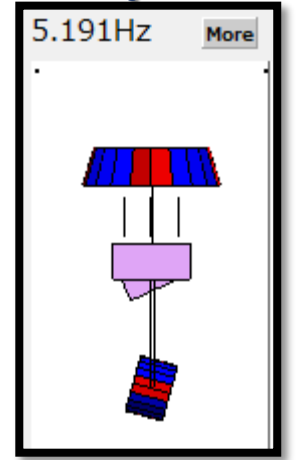

#17 : PIR

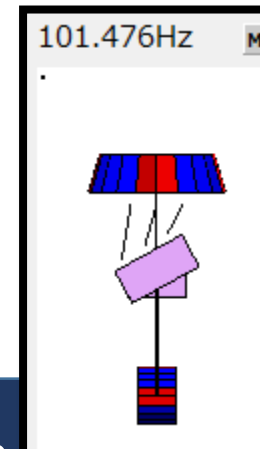

PR SAS Model for real iKAGRA PR3

Force Transfer Function

TypeBpp for iKAGRA (real configuration)

OSEM_YIM / actYIM

#1 : Whole chain

#7 : YIR

#12 : YIM / YIR

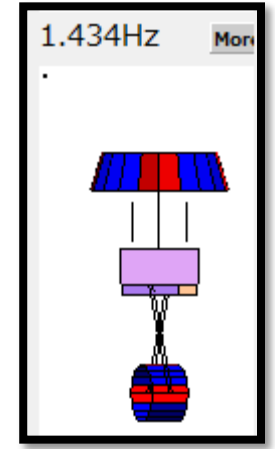
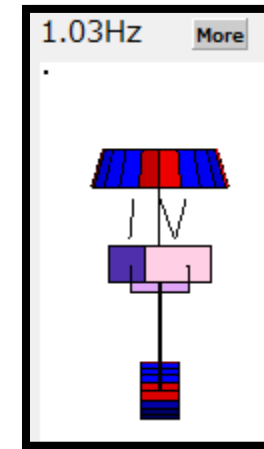
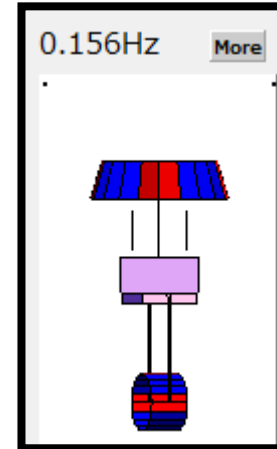
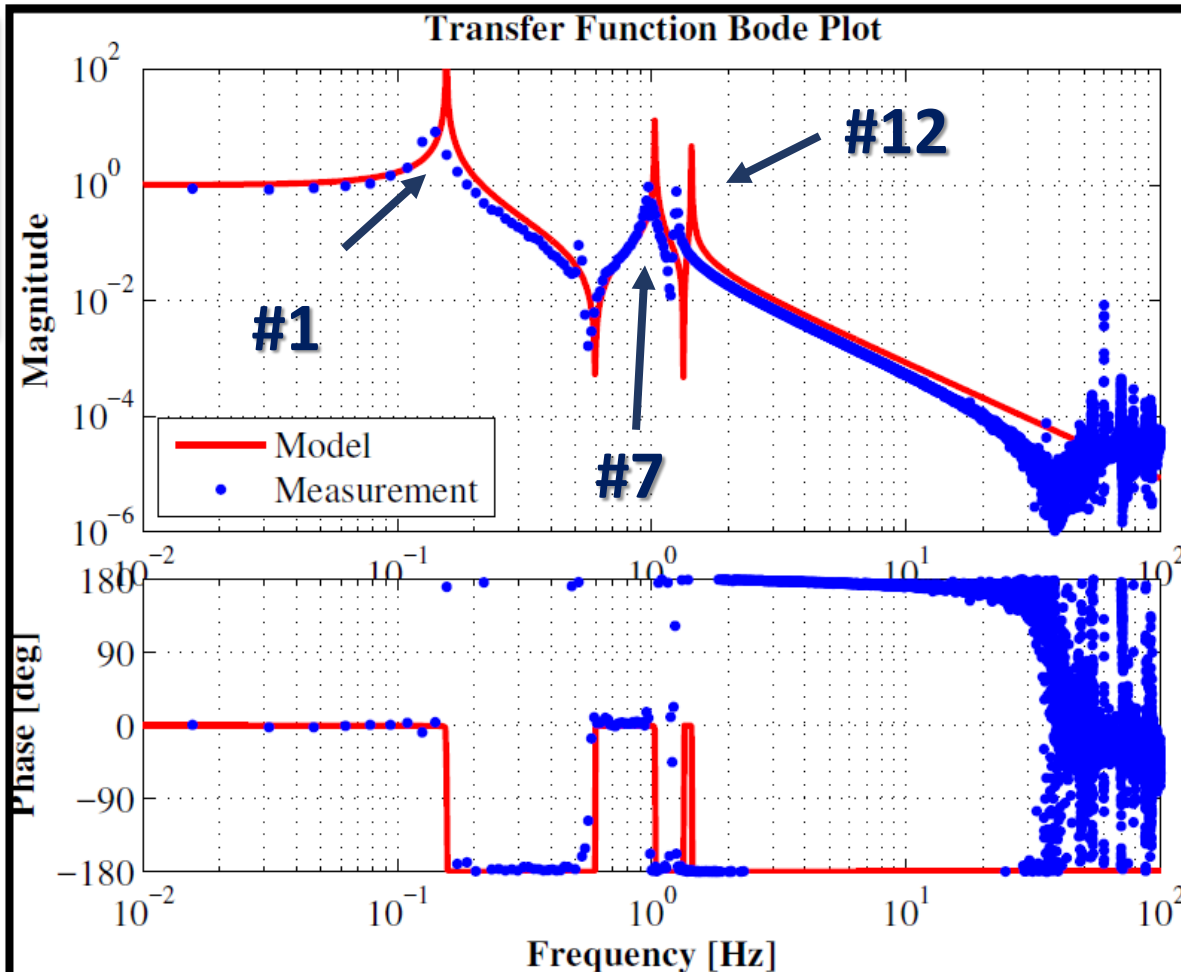
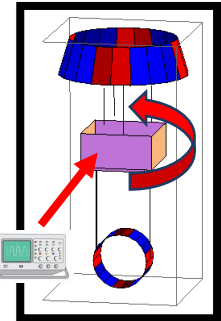

Force Transfer Function

TypeBpp for iKAGRA (real configuration)

Oplev PTM / actPIM

Transfer Function Bode Plot

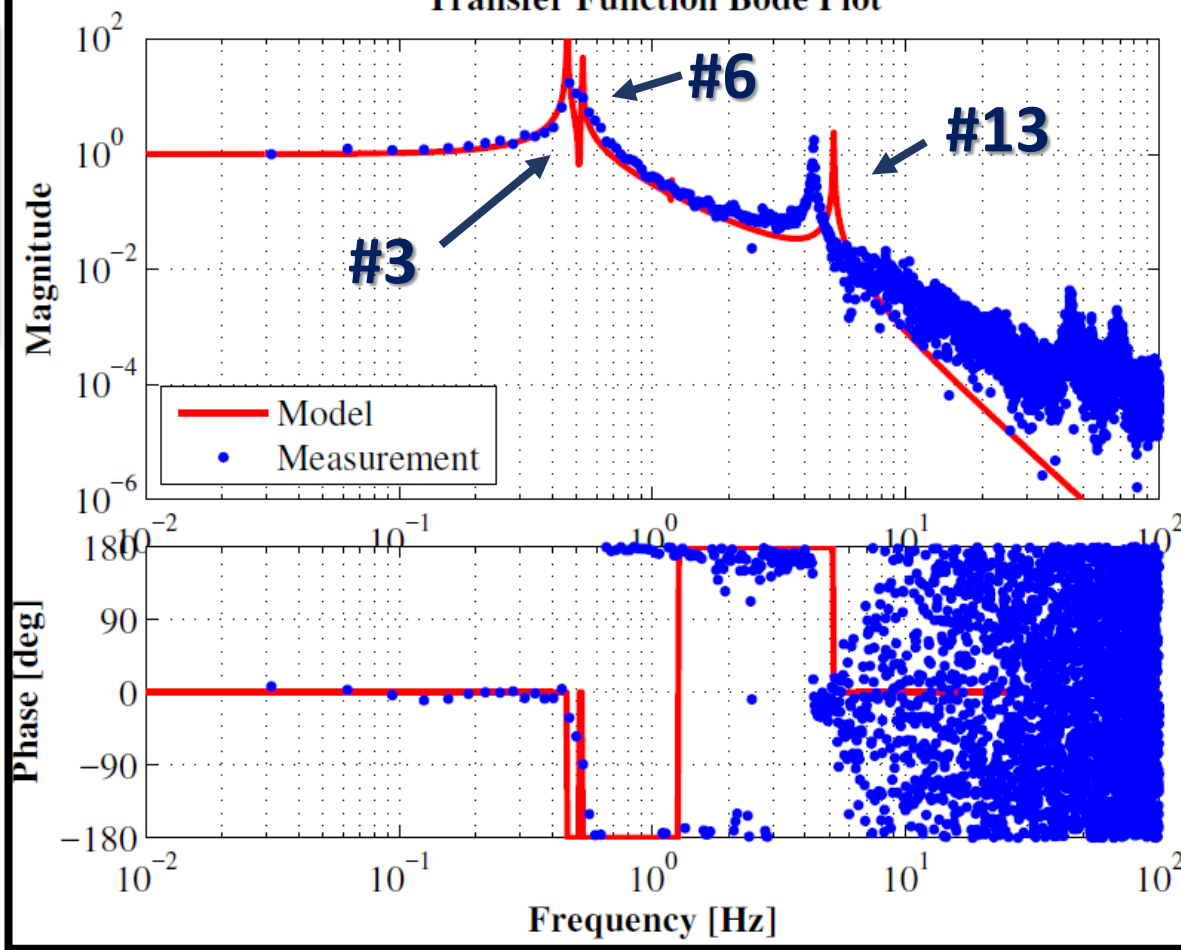

#3 : PIM
/PRM

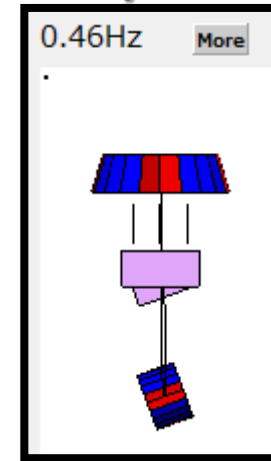

#6 : PIM
/PRM

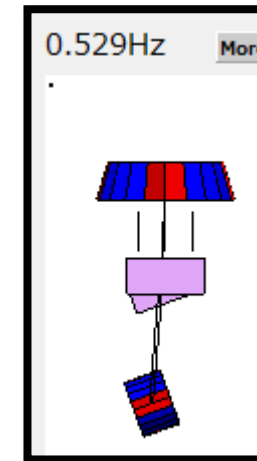

#13 : PIM
/PRM

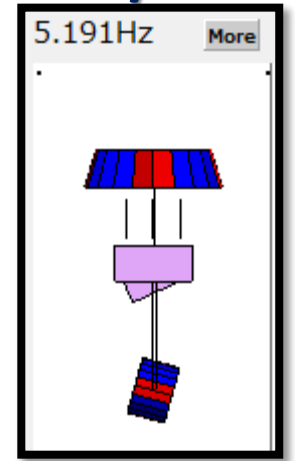

Force Transfer Function

TypeBpp for iKAGRA (real configuration)

OpLev_YTM / actYIM

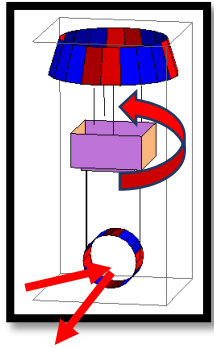

③ Installation test vs. SUMCON : TypeBpp_iKAGRA

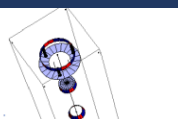

Investigation of TypeBpp Frequency response

LIM (OSEM) TF

REF : LIM (OSEM) TF of 20 m SAS

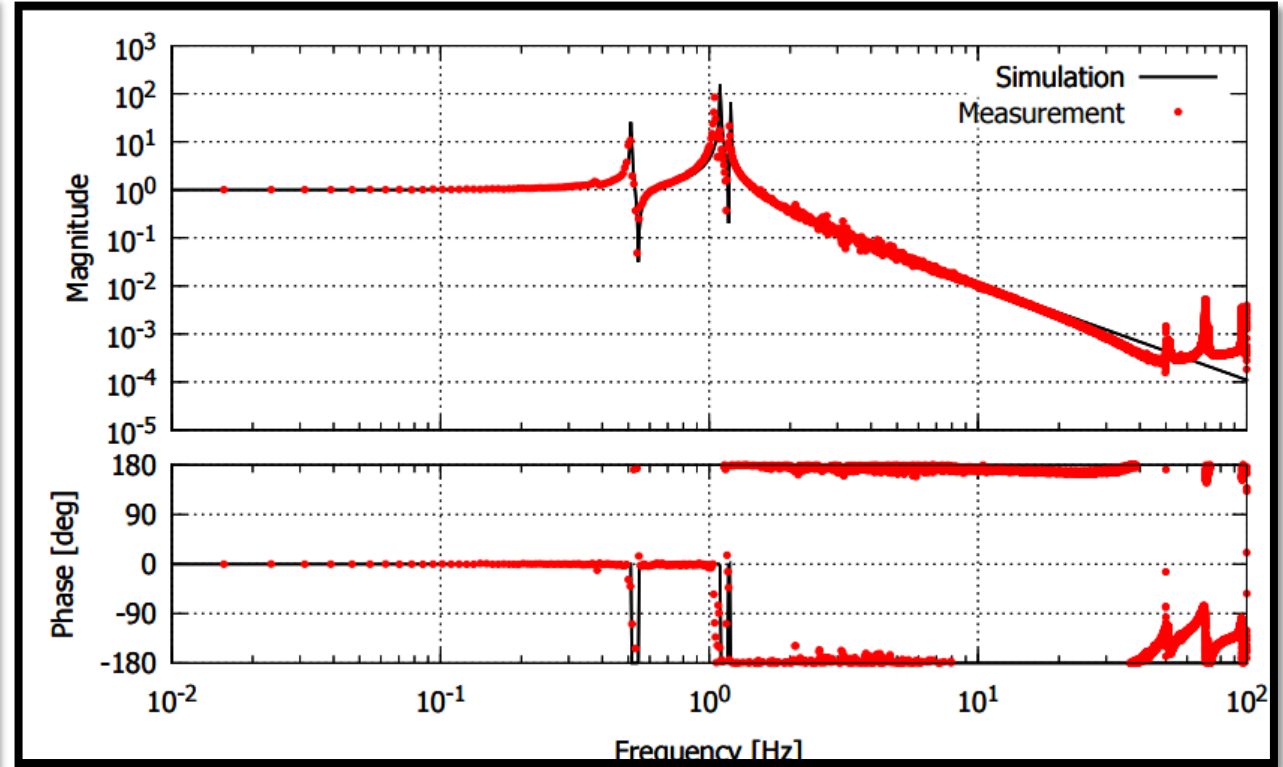
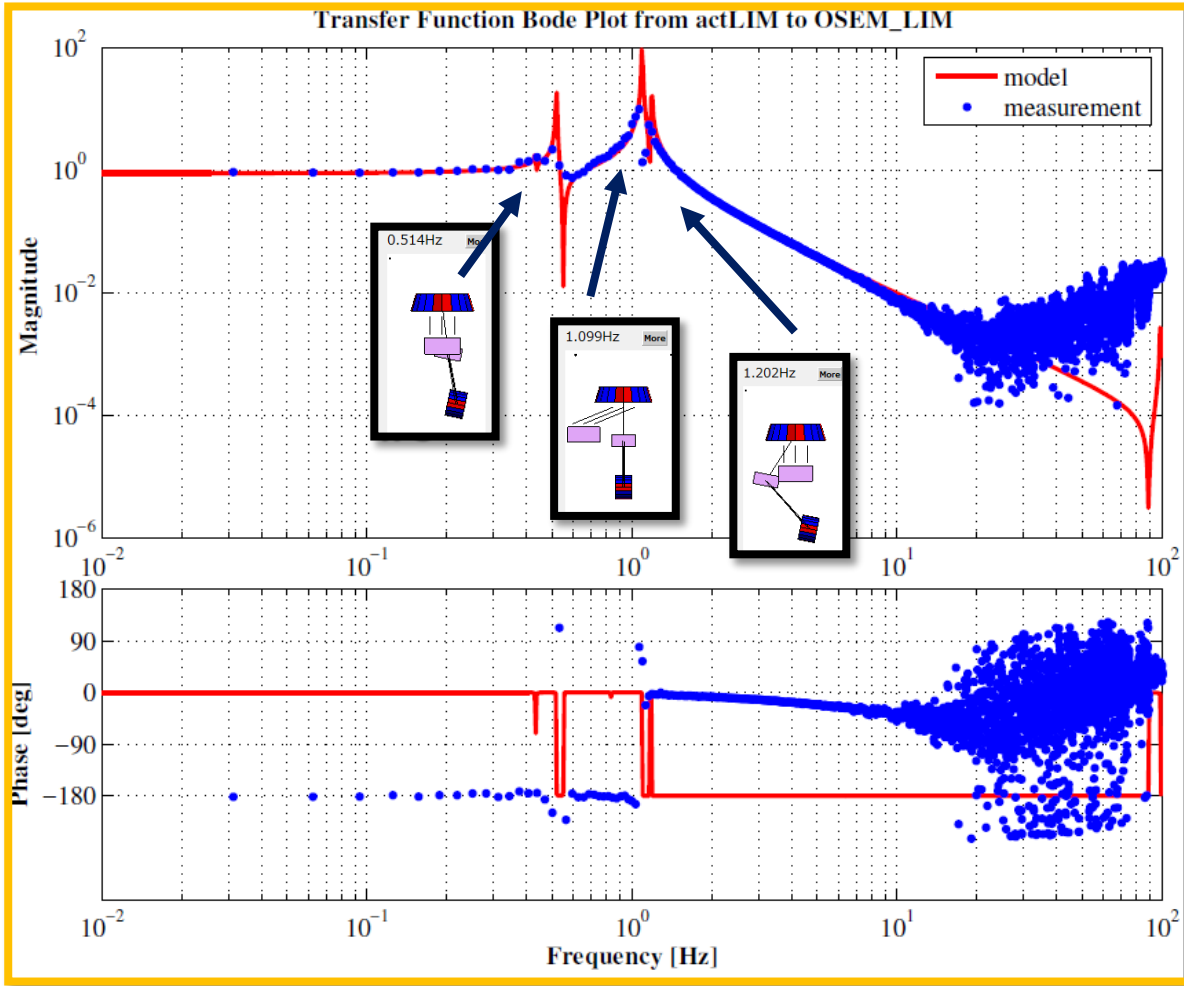

Investigation of TypeBpp Frequency response

PIM (OSEM) TF

REF : PIM (OSEM) TF of 20 m SAS

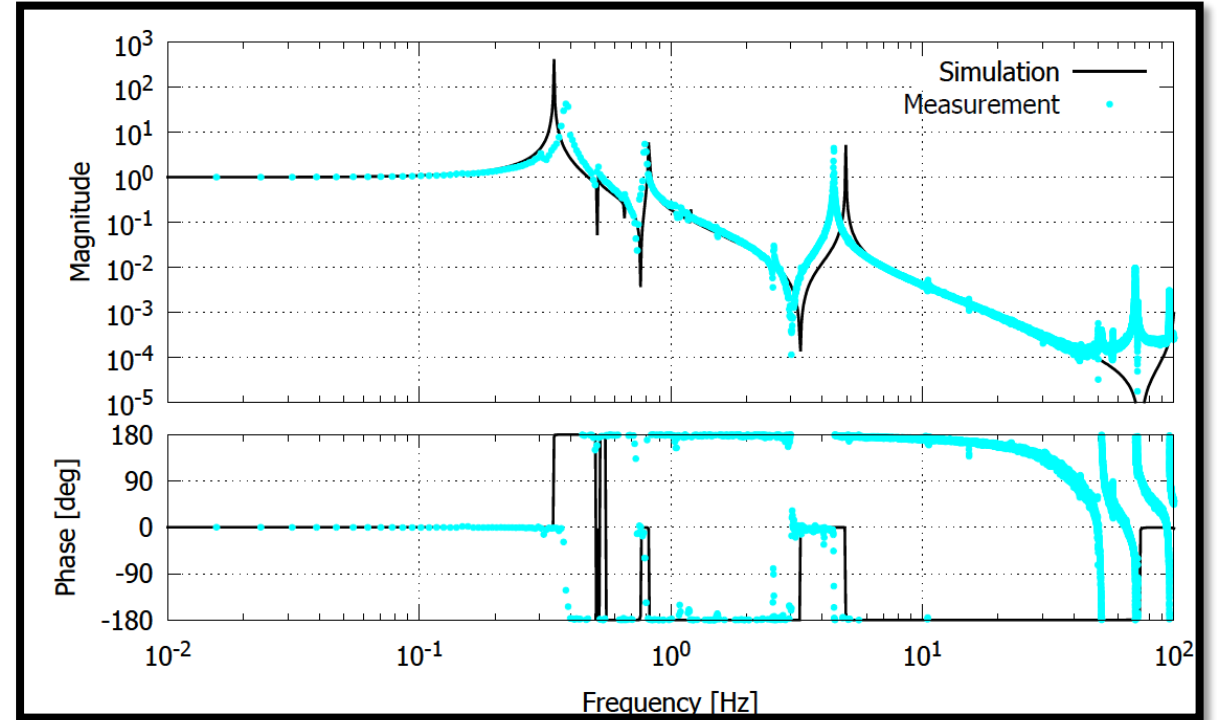
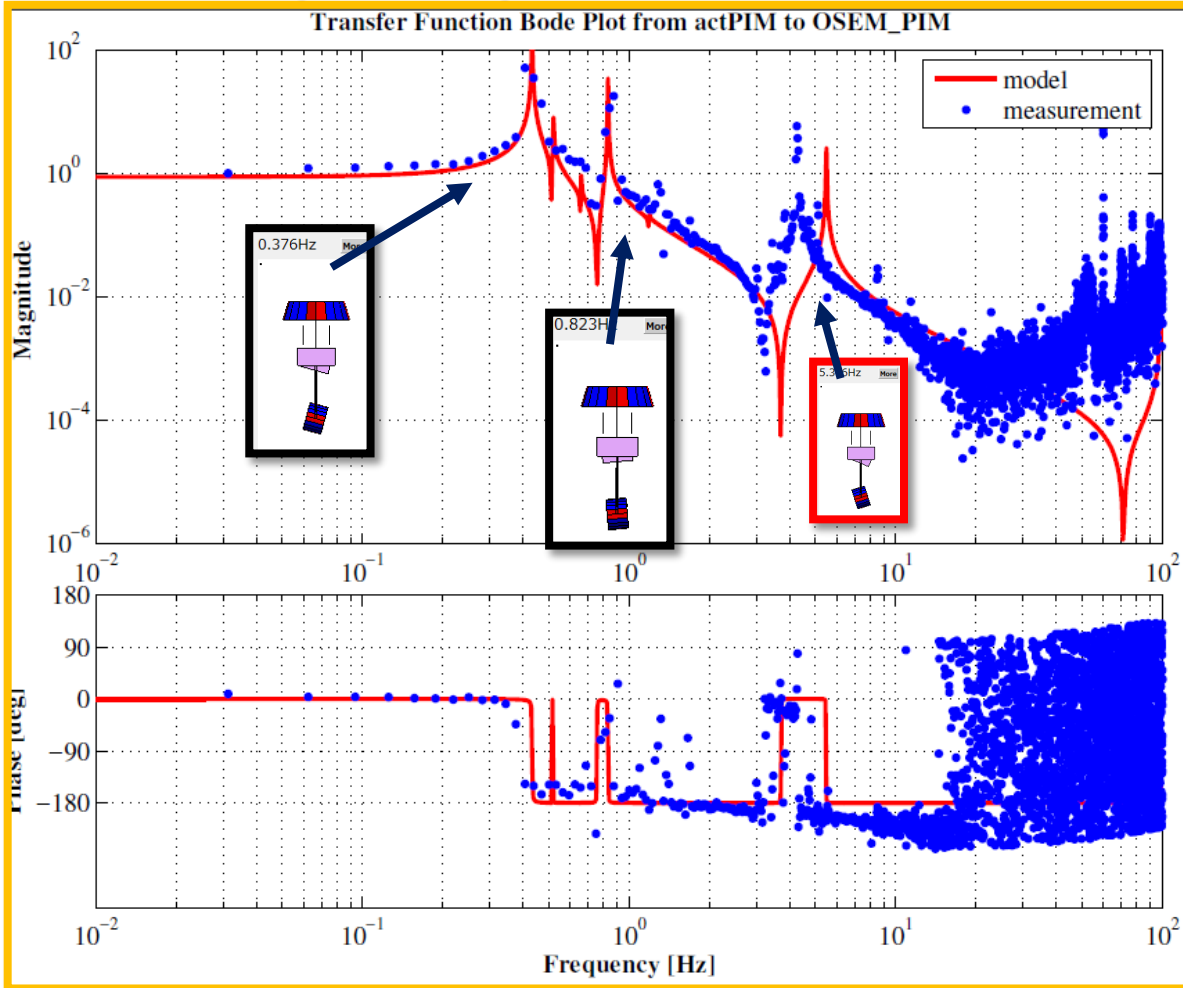

Resonance frequency is lower than its prediction by around 1 Hz.



To be investigated.

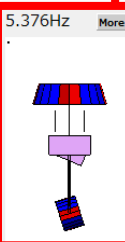

Investigation of TypeBpp Frequency response

RIM (OSEM) TF

REF : RIM (OSEM) TF of 20 m SAS

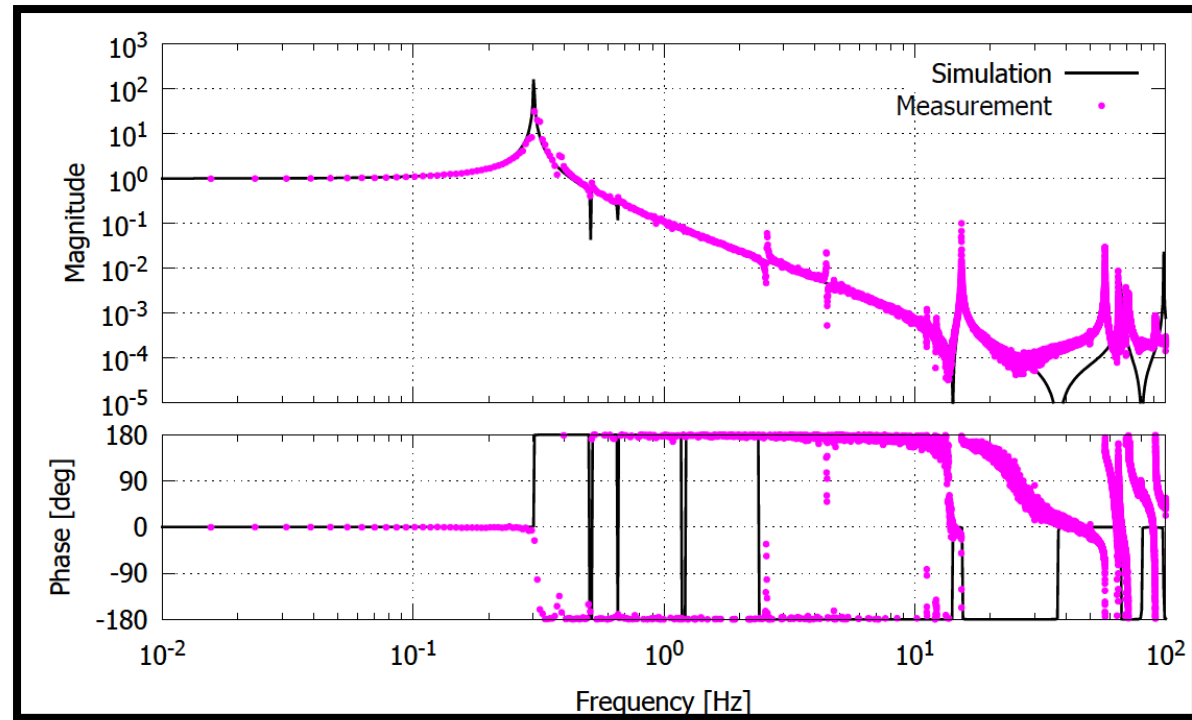
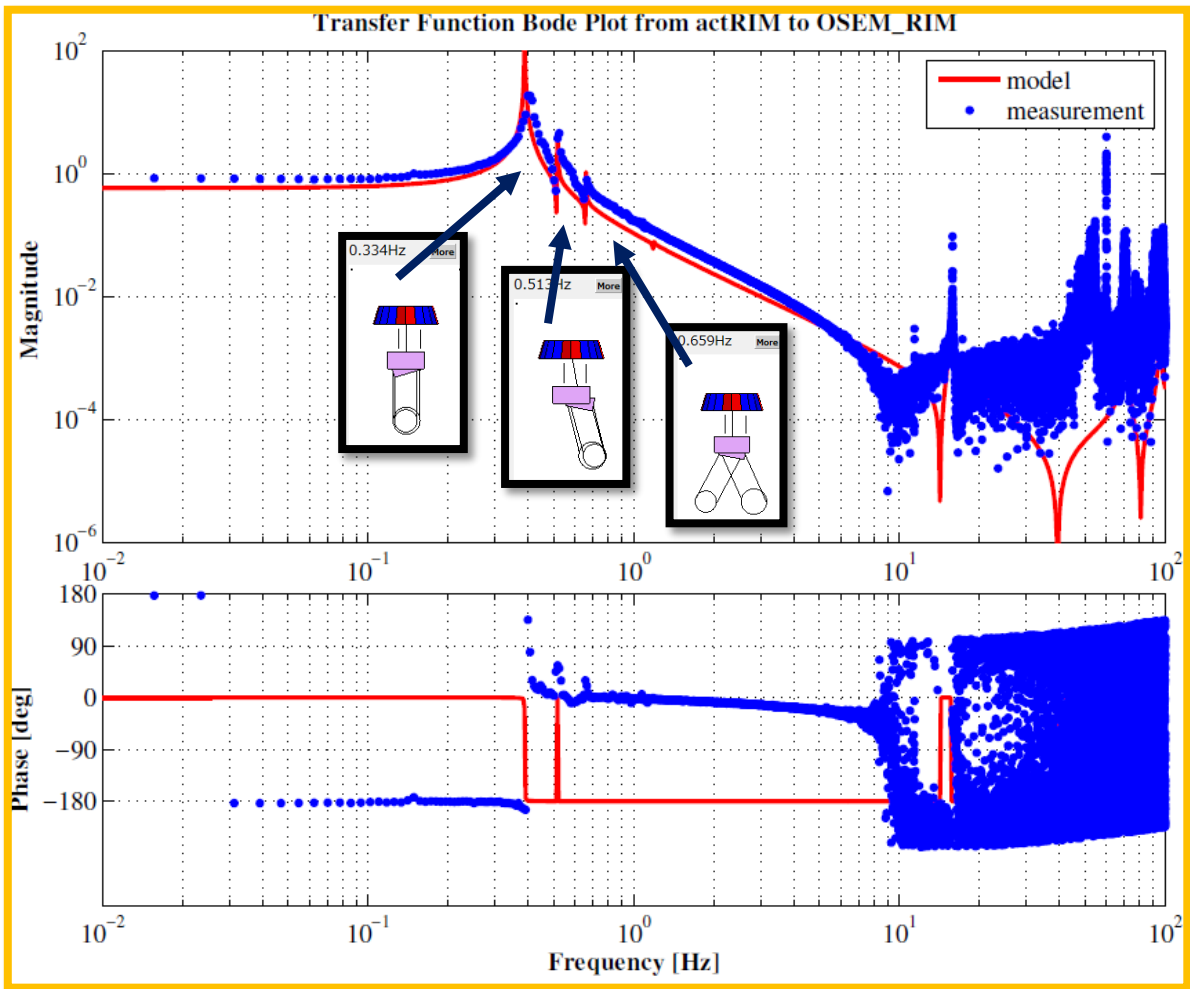

Investigation of TypeBpp Frequency response

LTM (OSEM) TF

REF : LTM (OSEM) TF of 20 m SAS

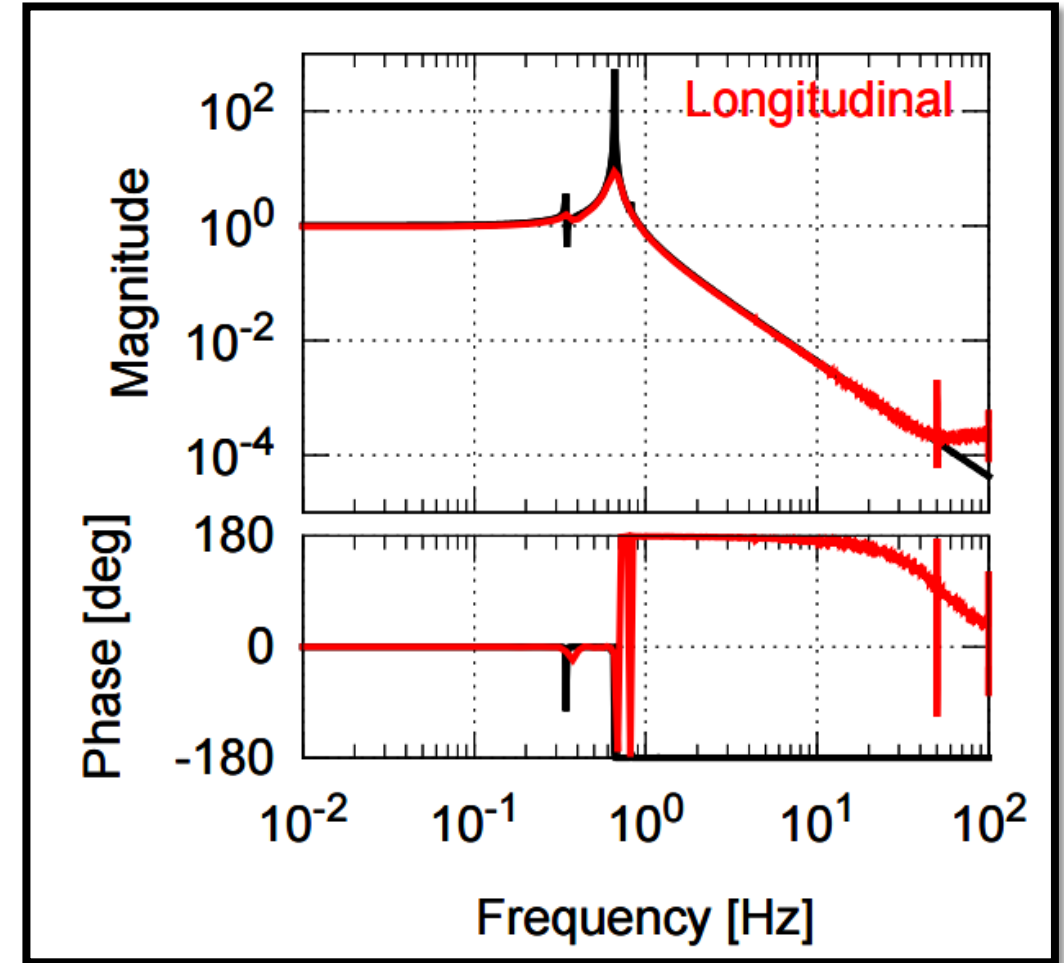
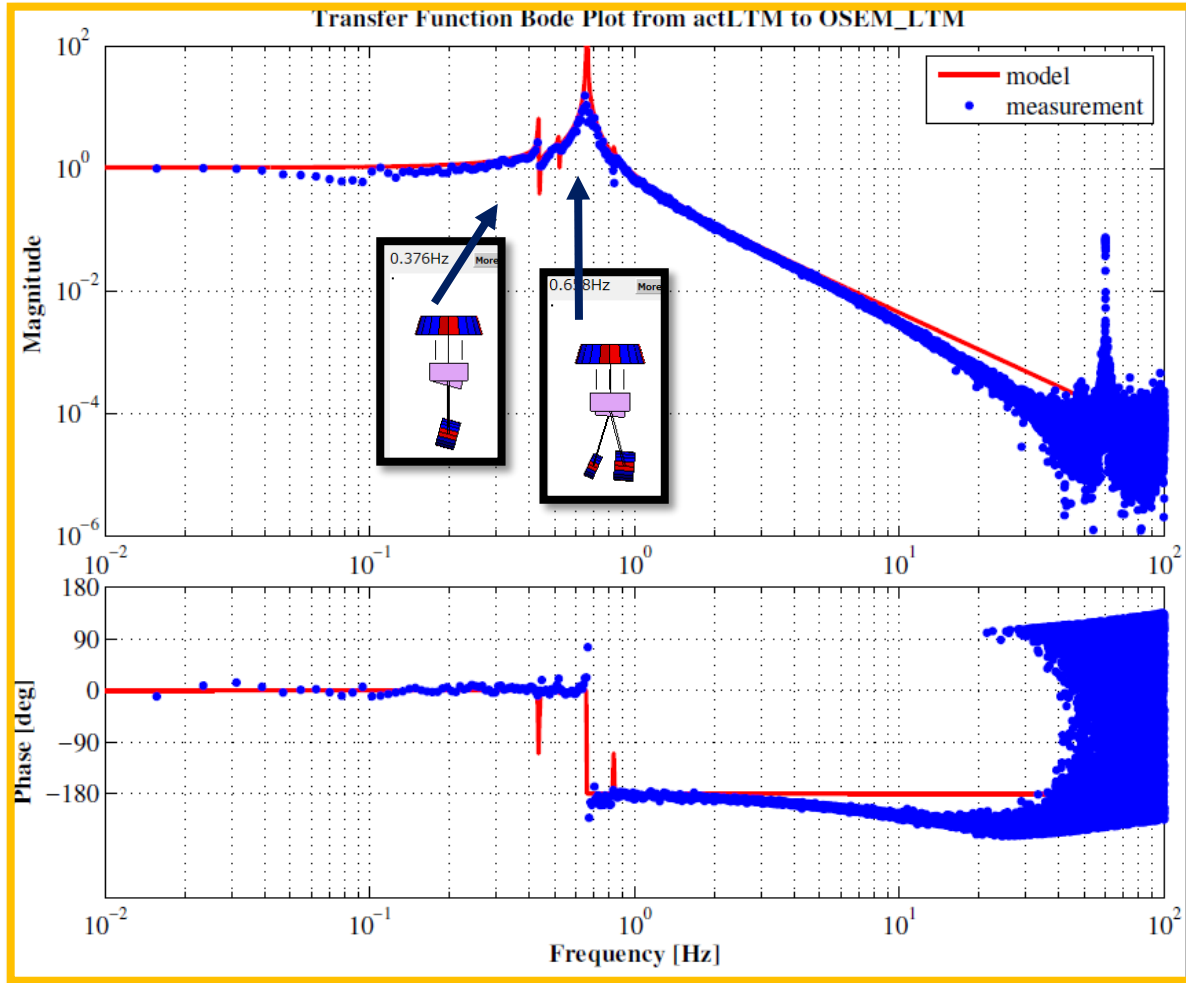

Investigation of TypeBpp Frequency response

PTM (OSEM) TF

REF : PTM (OSEM) TF in 20 m SAS

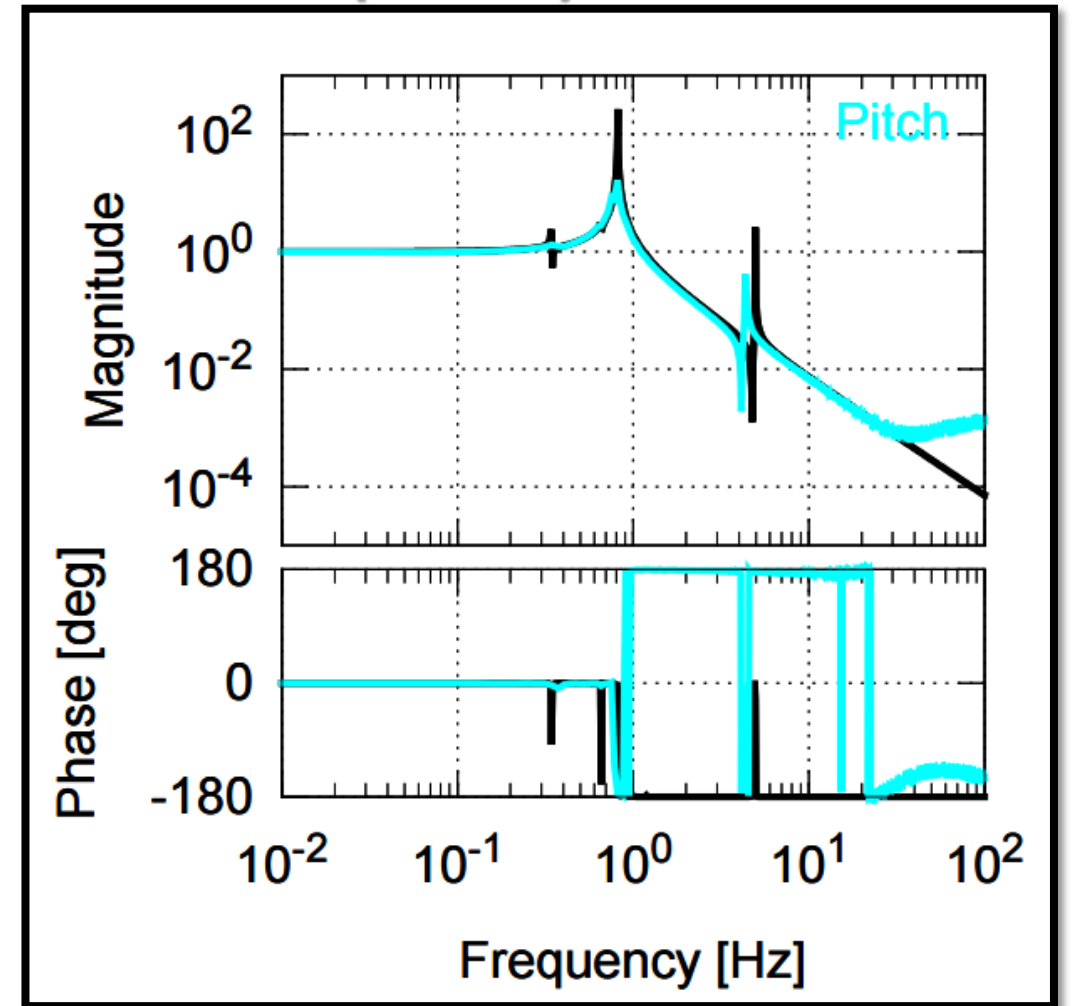
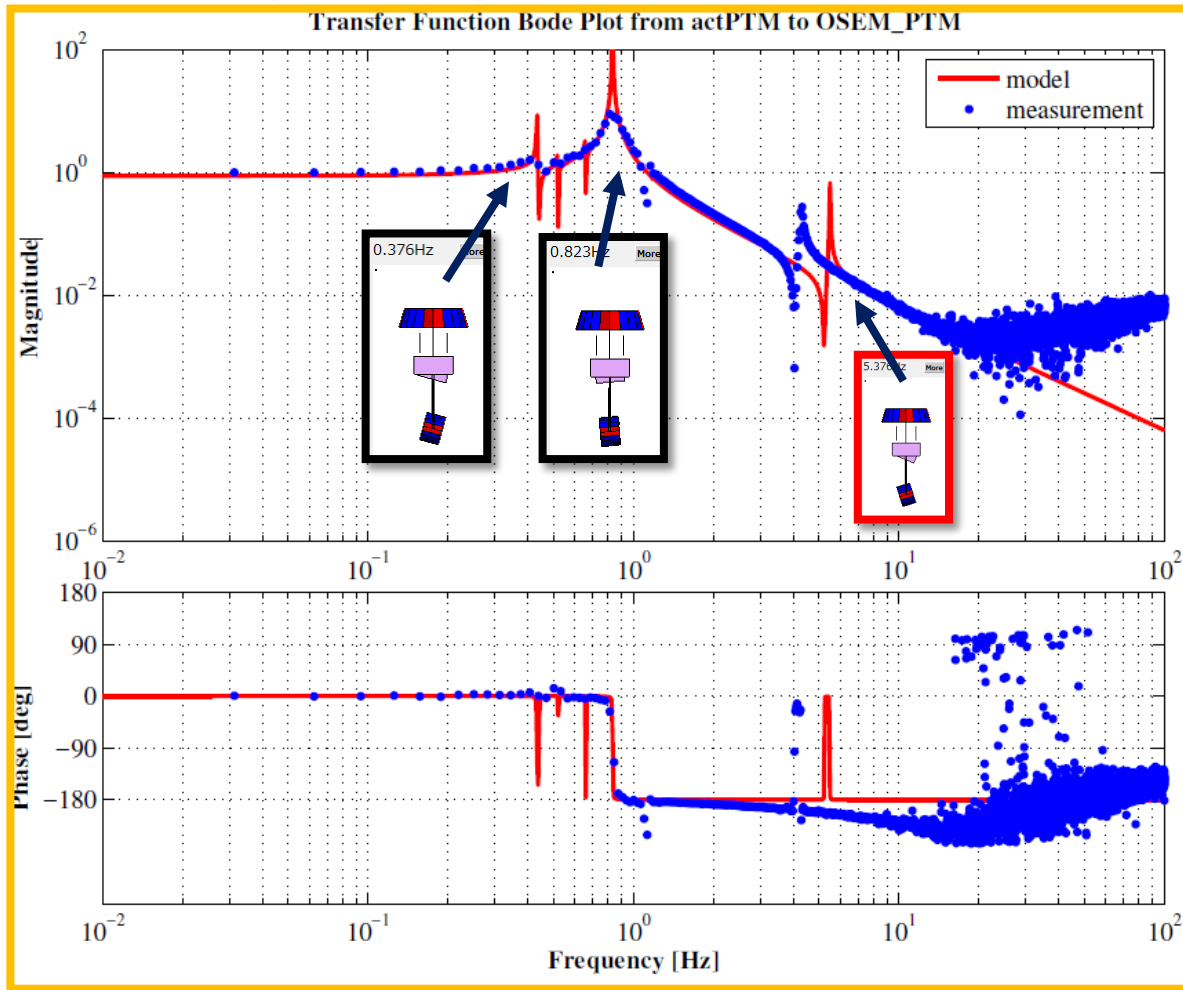

Investigation of TypeBpp Frequency response

PTM (Oplev) TF

REF : PTM (Oplev) TF of Type B1

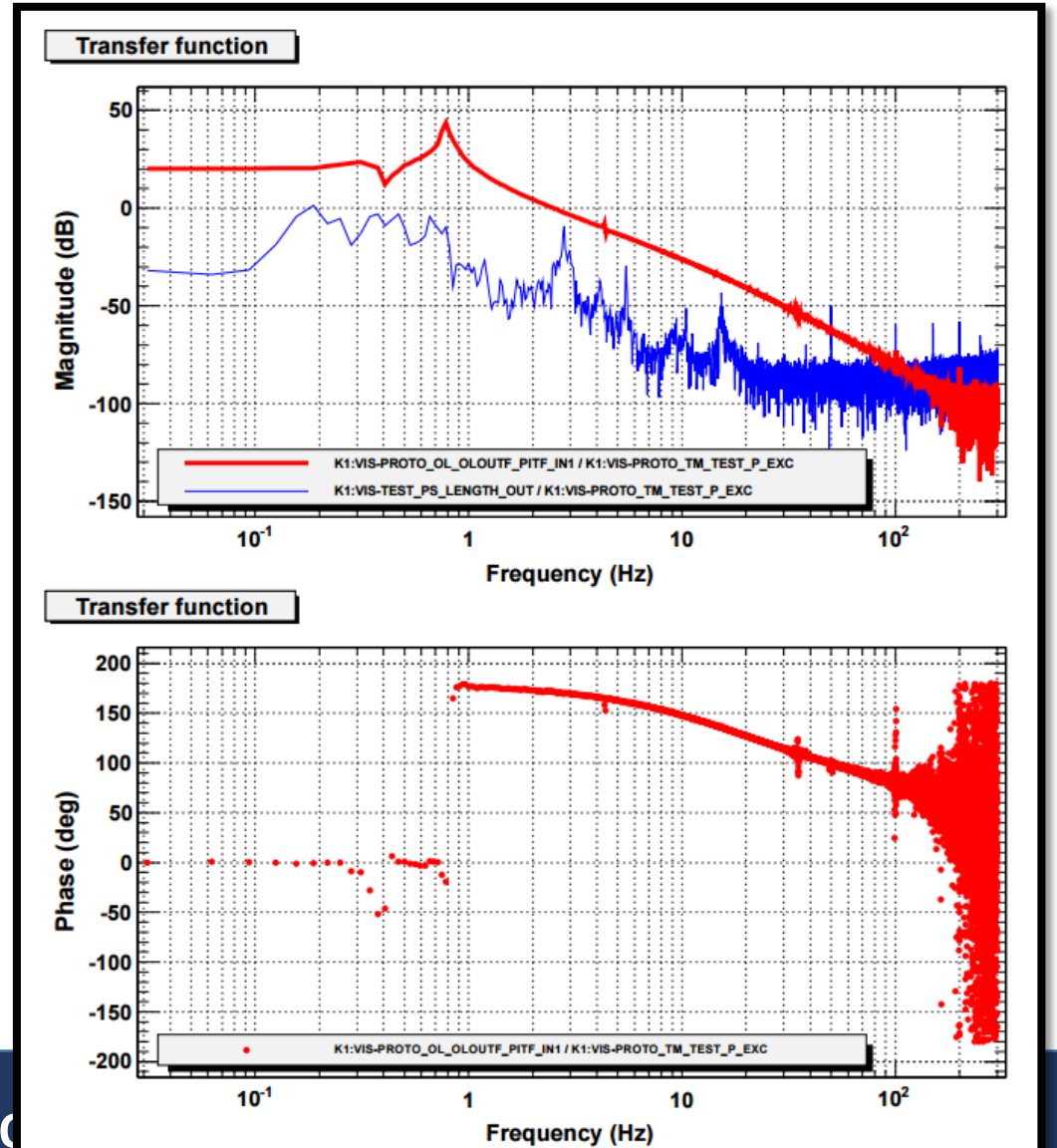
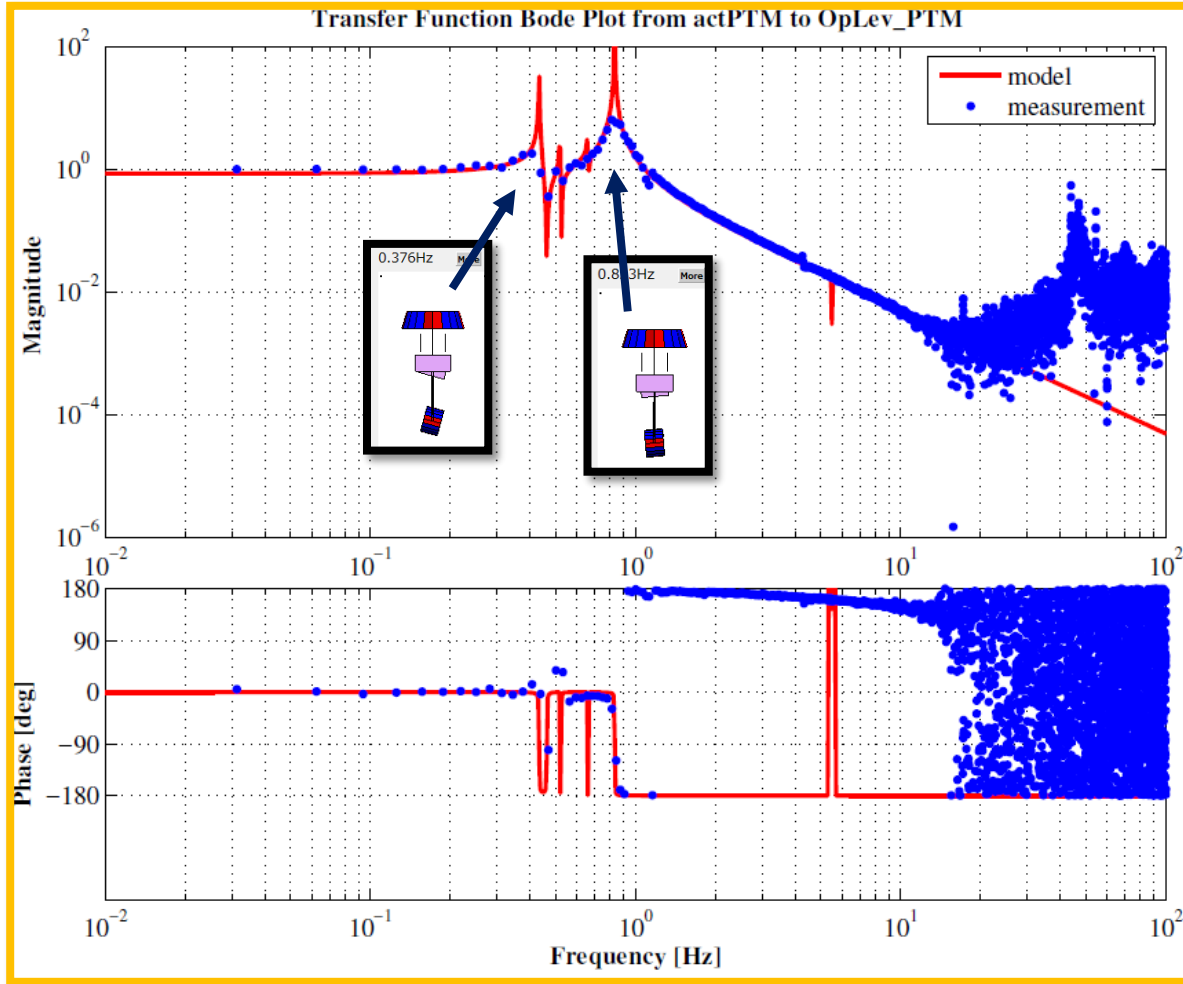

Investigation of TypeBpp Frequency response

YTM (OSEM) TF

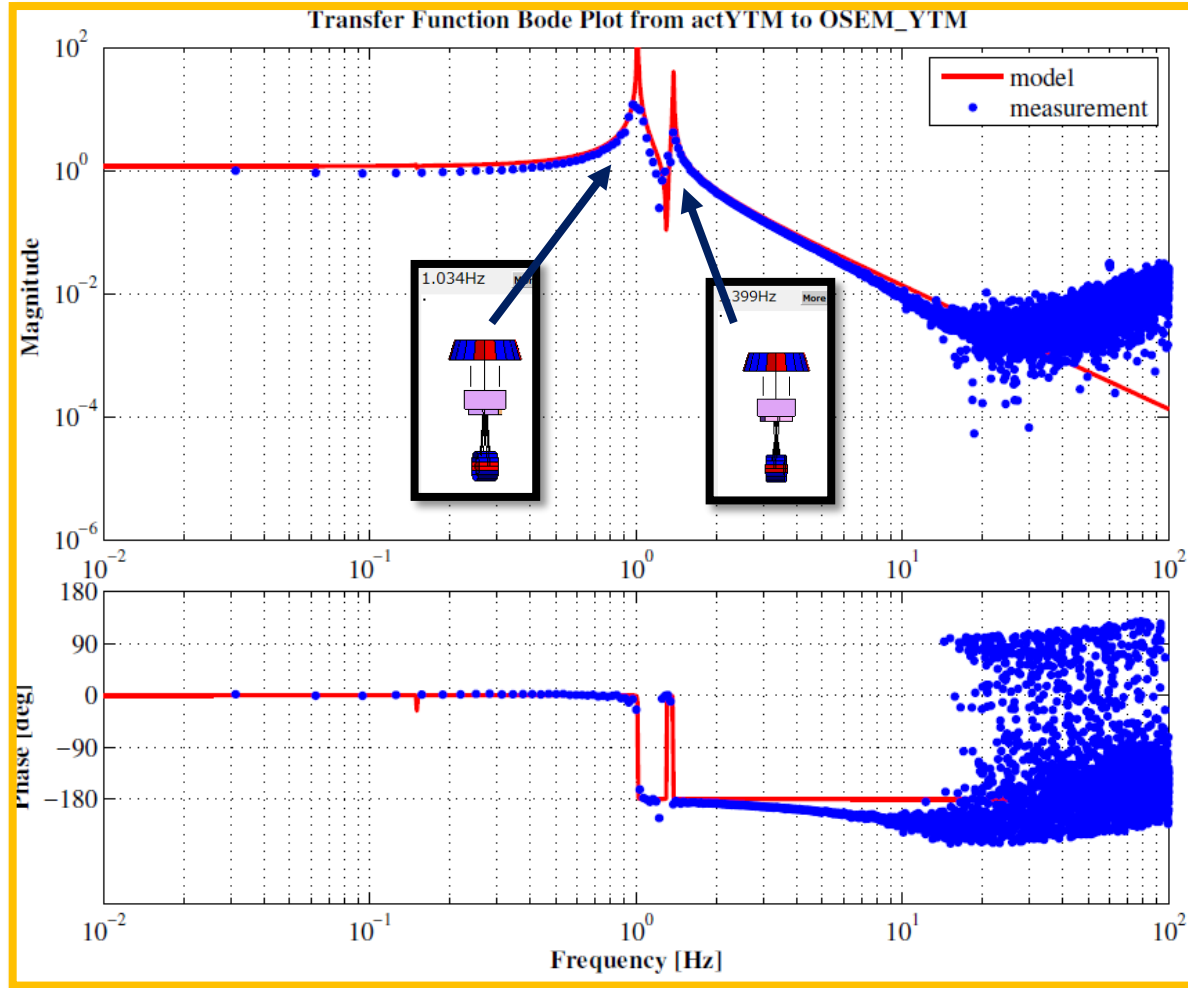

REF : LTM (OSEM) TF of 20 m SAS

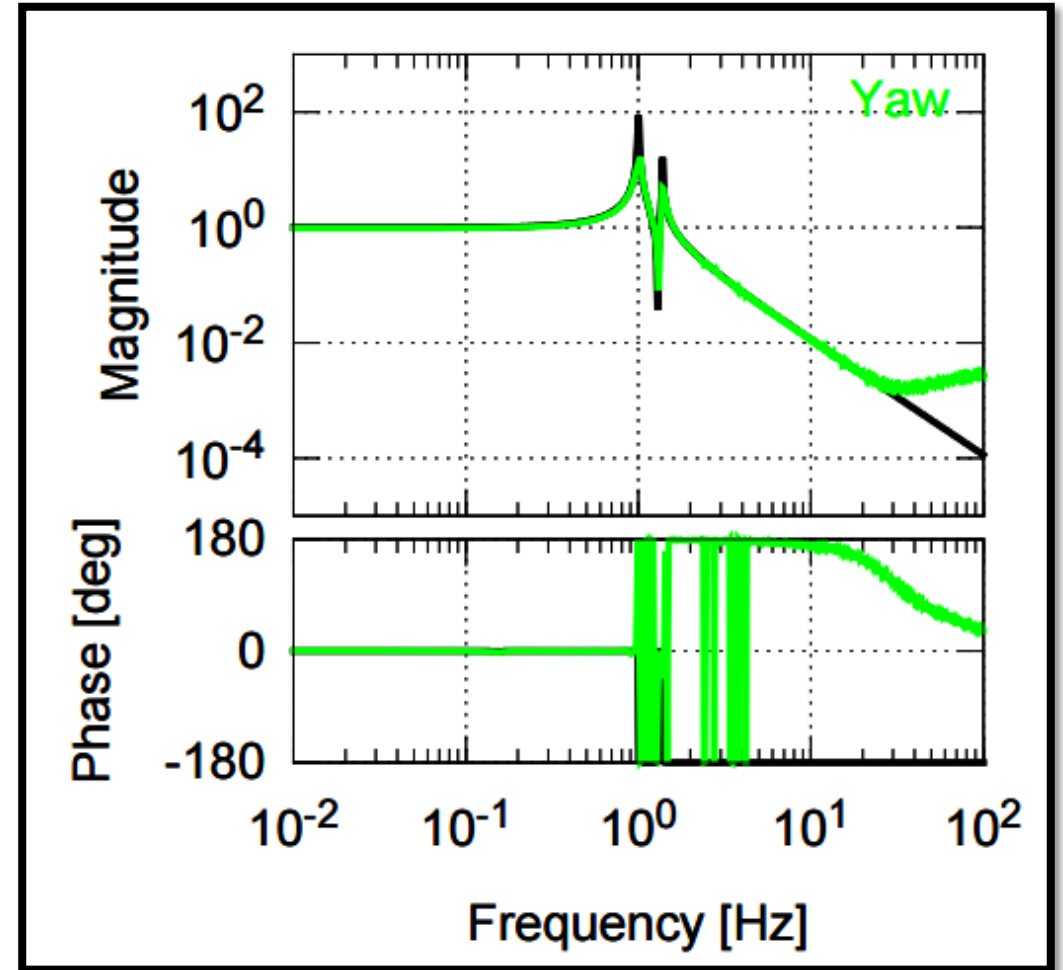

Investigation of TypeBpp Frequency response

YTM (Oplev) TF

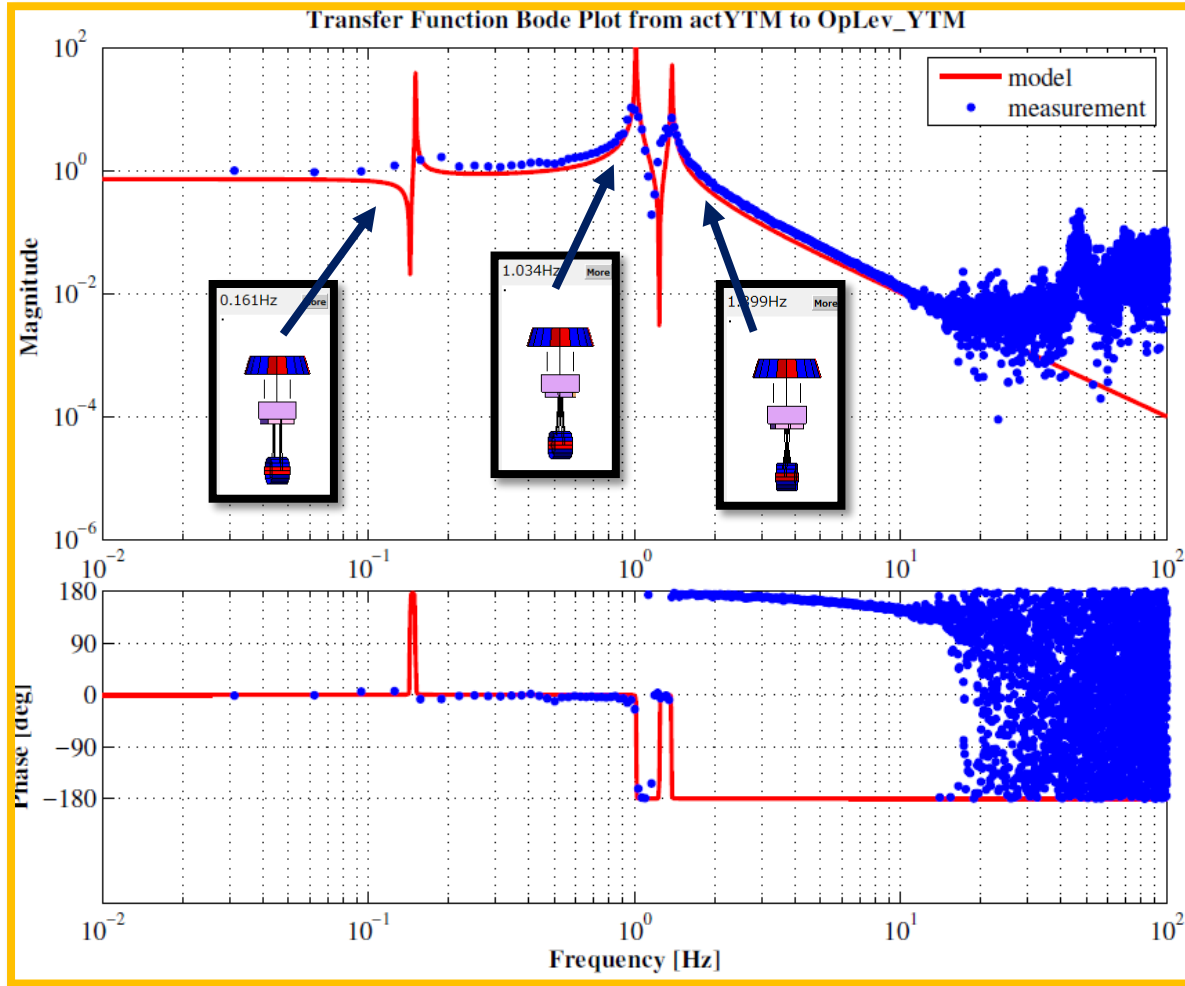

REF : YTM (Oplev) TF of Type B1

