

# Procedure of assembly of the payload

JGW-E1503830-v8draft

Fabián Erasmo Peña Arellano

7th October 2015

# 1 Introduction

This document describes the procedure of hanging the mirror (TM) and the recoil mass (RM) from the intermediate mass (IM). The 3D CAD model used to produce the images was provided by Hirata-san.

Please note the following:

1. Intermediate mass must be assembled with the exception of few sub-assemblies:
  - a) No OSEM flags.
  - b) Four free threaded holes at the upper side of the IM for attachment of the winch fixture.
  - c) The clamp assemblies at the sides should not have the clamps in position.
2. Screws M5 and above must be vented always.

## 2 Assembly of Recoil Mass

1. We begin with the cylindrical part



2. Take the wire breakers  $2 \times \text{U00015-434}^1$ , put them in the grooves on the flats on the sides of the cylinder and fasten them with the clamps  $2 \times \text{U00032-435}^2$  and with the screws  $4 \times \text{ISO 4762 M3} \times 8$  coated.

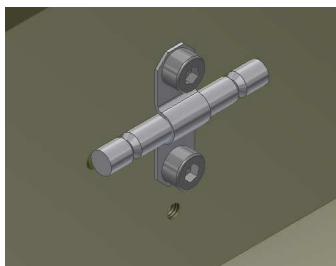

3. Assemble the multipurpose cube  $\text{U00013-427}^3$  with the cable clamp support  $\text{U00029-428}^4$ . Use the following screws and nuts:  $4 \times \text{DIN EN ISO 2009 M2.5} \times 8$  mm uncoated and  $4 \times \text{UNI EN 24032 M2.5}$ .

---

<sup>1</sup>wire\_breaker\_RM

<sup>2</sup>clamp\_wire\_breaker\_RM

<sup>3</sup>Part-19-damper\_new

<sup>4</sup>Part-22-support\_cables\_on\_mirror\_new\_v4

## 2 Assembly of Recoil Mass

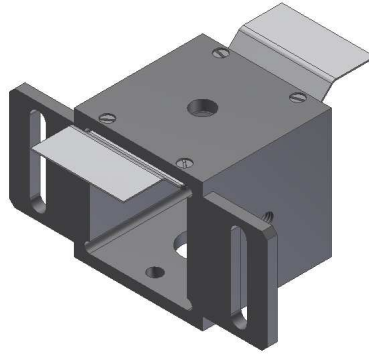

4. Fix the multipurpose assembly on top of the RM. Use the following fasteners:  
2×ISO 4762 M5 x 12 mm coated.

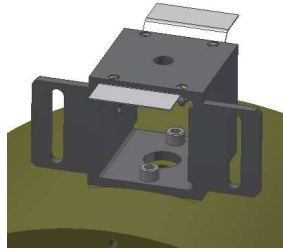

5. Assemble 5×screw\_side assembly, which are earthquake stop screws for the optic.  
Use the following items:

- a) Name: TM stopper side2, description: 5×ISO 4762 M8×25 mm perforated screws with a M2×0.4 threaded hole and coated.
- b) Screws: 5×SSHS-M2-6-SD\_2\_03 M2×0.4×6 mm<sup>5</sup>. Coated.
- c) PTFE head: 5×head cylinder<sup>6</sup>.

---

<sup>5</sup>Maybe “M2 plus screws” on the list according with Okutumi-san. Please clarify

<sup>6</sup>head\_cylinder

## 2 Assembly of Recoil Mass

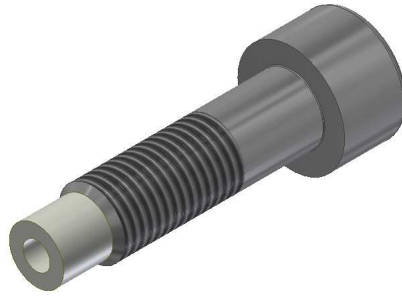

6. Insert them into the cylinder. One at 12 o'clock where the multipurpose cube is, two at 5 o'clock and two at 7 o'clock. Use the following nuts: 5×UNI\_EN\_24032\_M8\_2. Set the threaded part of the nut towards the cylinder.

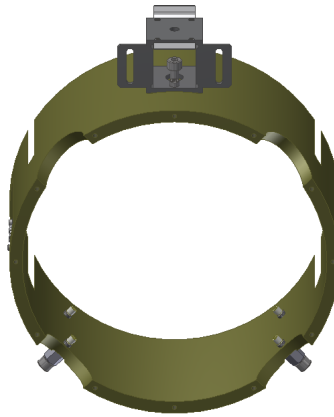

7. Place the back ring `part_3_back_recoil_mass_v3` on the back side of the RM (with OSEM cut-outs) and fix it with 12×ISO 4762 M5×18 mm coated. Please note that the plate is not symmetric with respect to the horizontal plane.

## 2 Assembly of Recoil Mass

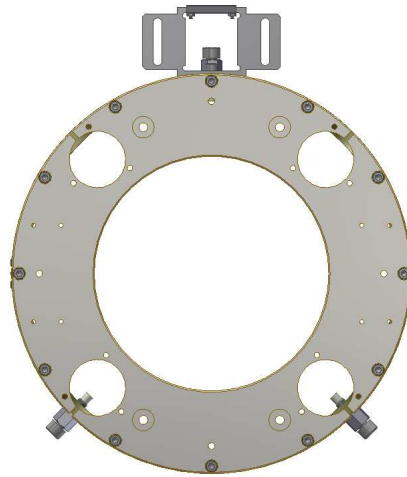

8. Fix the OSEM to the back ring of the RM. Use the following fasteners:

- 1×ISO 4762 M5×16 mm. Uncoated for pushing. Total: 4
- 3×ISO 4762 M5×20 mm. Coated for pulling. Total: 12.
- 2×ISO 4762 M5×40 mm. Uncoated for pushing. Total: 8.

## 2 Assembly of Recoil Mass

ISO 4762 M5 x 16, push

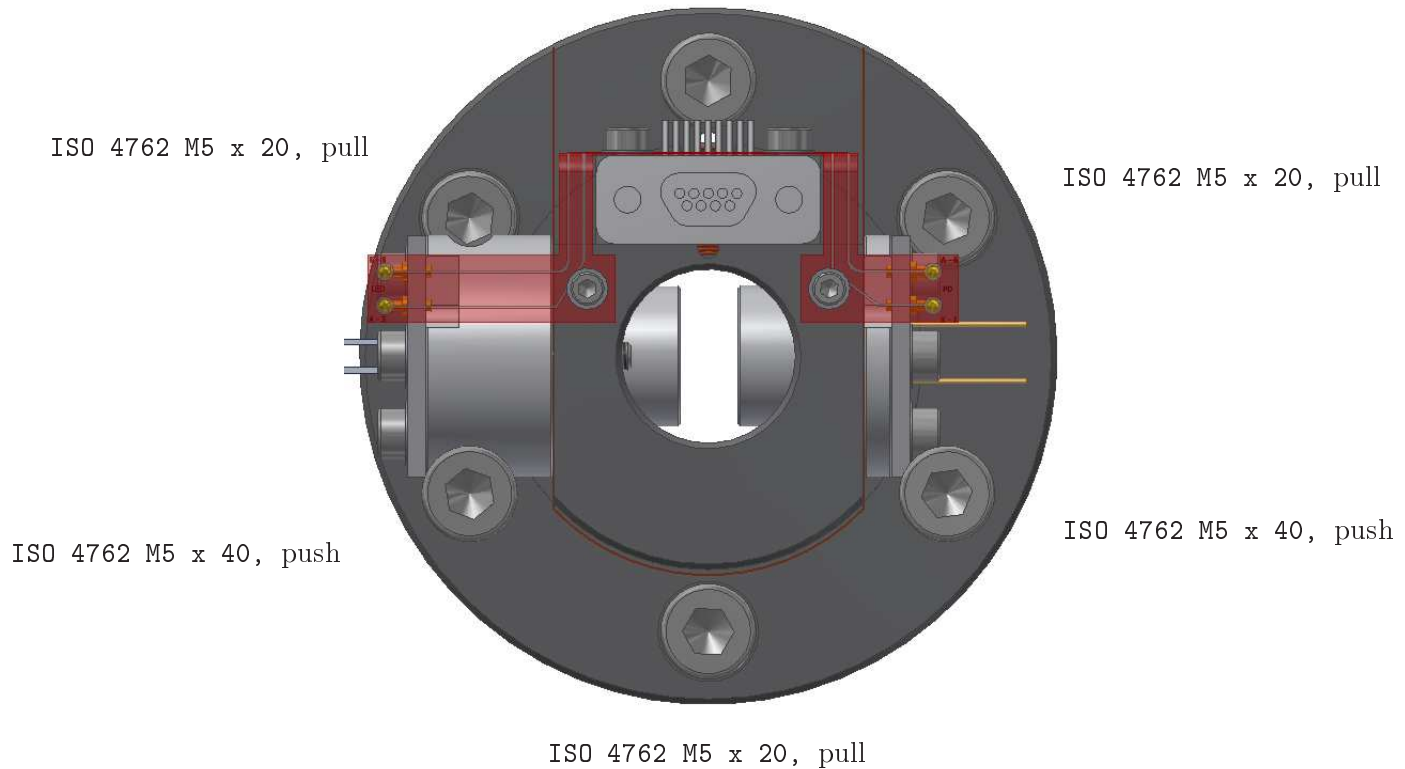

9. Place the OSEM on the back ring. There should be a log<sup>7</sup> with the OSEM part number and the position of each OSEM in the RM. Please follow a similar convention to the one used in TAMA. The spacing between the OSEM body and the back ring should be 6.5 mm.

---

<sup>7</sup>There is a paper notebook inside the clean room. Fujii-san has been writing on it.

## 2 Assembly of Recoil Mass

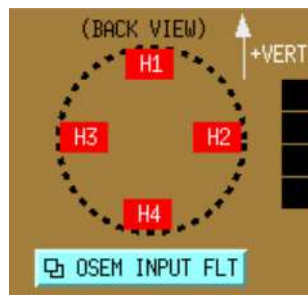
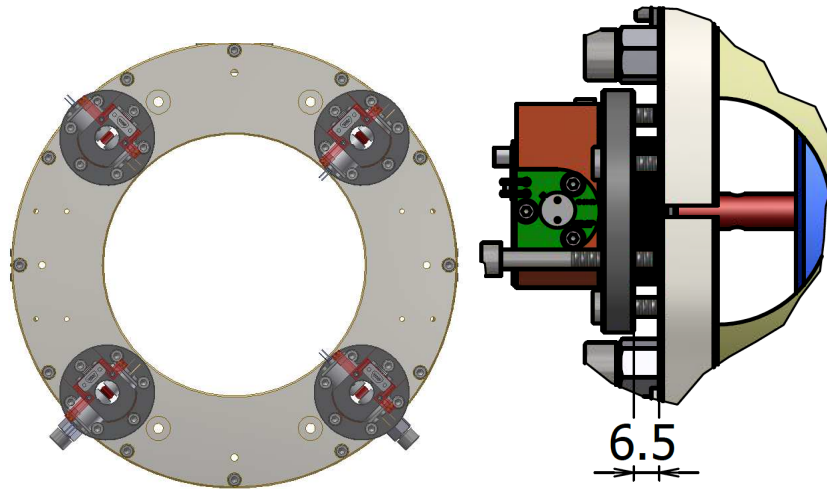

TAMA

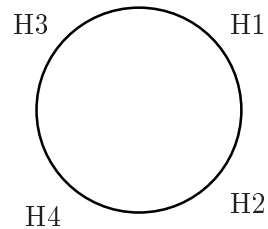

KAGRA

10. Assemble 4×`screw_back`, which are earthquake stop screws for the optic. Use the following items:

- a) Perforated screws: 4×ISO 4762 M8 x 40 mm. They have a M2×0.4 threaded hole. Coated. **MISSING**.
- b) Screws: 4×SSHS-M2-6-SD\_2\_03 M2×0.4<sup>8</sup>. Coated.
- c) PTFE head: 4×`head_cylinder`<sup>9</sup>.

<sup>8</sup>Maybe “M2 plus screws” on the list according with Okutumi-san. Please clarify

<sup>9</sup>`head_cylinder`



## 2 Assembly of Recoil Mass



11. Insert them into the cylinder. One at 2, 4 , 6 and 10 o'clock. Use the following nuts: 4×UNI\_EN\_24032\_M8\_2. Set the threaded part of the nut towards the back plate.

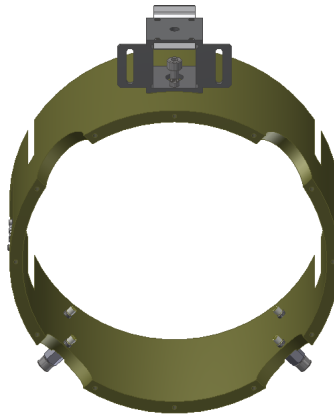

12. Put on the back ring the following items:

- a) At 12 o'clock: F00020\_F020<sup>10</sup>. Use ISO 4762 M6 x 25 mm. Coated.
- b) At 3 o'clock: F00020\_F020<sup>11</sup>. Use ISO 4762 M6 x 25 mm. Coated.
- c) At 6 o'clock: F00021\_F021<sup>12</sup>. Use ISO 4762 M6 x 35 mm. Coated.
- d) At 9 o'clock: F00020\_F020<sup>13</sup>. Use ISO 4762 M6 x 25 mm. Coated.

---

<sup>10</sup>Part-27-counterweight\_thick\_new

<sup>11</sup>Part-27-counterweight\_thick\_new

<sup>12</sup>Part-27-counterweight\_thick\_new\_bottom

<sup>13</sup>Part-27-counterweight\_thick\_new

## 2 Assembly of Recoil Mass

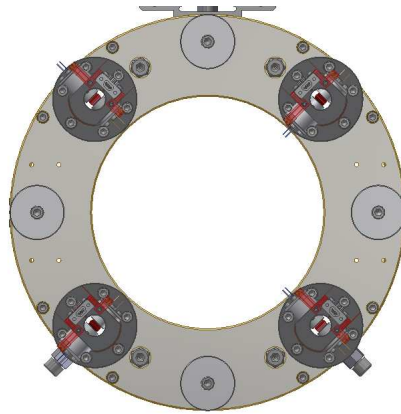

13. Place  $4 \times$  `clamp_on_TM` on back ring. Use  $8 \times$  ISO 4762 M4 x 10 mm coated.



14. The recoil mass is ready to be brought around the optic.

15. Assemble  $4 \times$  `screw_front` assembly, which are earthquake stop screws for the optic. They are to be mounted on the front ring of the RM. After assembly put them aside. They will be used in step 35. Use the following items:

- Name: `PRTM stopper front`, description:  $4 \times$  ISO 4762 M8 $\times$ 50 mm perforated screws with a M2 $\times$ 0.4 threaded hole and coated.
- Screws:  $5 \times$  SSSS-M2-6-SD\_2\_03 M2 $\times$ 0.4 $\times$ 6 mm<sup>14</sup>. Coated.
- PTFE head:  $5 \times$  `head cylinder`<sup>15</sup>.

---

<sup>14</sup>Maybe “M2 plus screws” on the list according with Okutumi-san. Please clarify

<sup>15</sup>`head_cylinder`

*2 Assembly of Recoil Mass*



### 3 Bill of materials

1. 4 × ISO 4762 M6×35 mm surface treated screws.
2. Bubble level.
3. 8 × pins part number ALPSTAG10-L20\_0-E2\_0-A15. These likely come with the frame.
4. 2 × C-clamps.
5. 4 × M5 × 45 mm screws.
6. 4 × M5 plain washers.
7. 4 × ISO 4762 M5 × 30 mm.
8. 4 × ISO 4762 M6×70 mm.
9. 4 × ISO 4762 M12×35 mm screws. These are for the pillars of the earthquake stop at the IM level.

## 4 Hanging the mirror

1. We begin with the bare frame. Please note the following:
  - The base of the frame has four M6 clear holes at the vertices of a  $500 \times 400$  mm rectangle. Please use these holes to fix the frame on an optical breadboard or table using  $4 \times$  ISO 4762 M6 $\times$ 35 mm surface treated screws (listed in item 1 in Sec. 3).
  - Use a bubble level to level the base of the frame straight. (Item 2 in Sec. 3.)

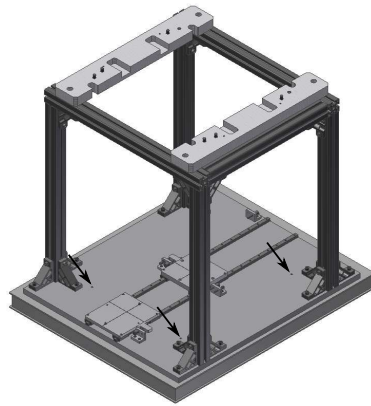

2. Assemble the earthquake stop ring for the IM. Use the following components:
  - a)  $1 \times$  Part-10004-safety structure disk,
  - b)  $(4 \times$  Part-10007-rod security structure 526. Each rod requires the following fasteners: M12  $\times$ 35mm)
  - c)  $2 \times$  Part-10022-safety intermediate mass. Each part requires:  $2 \times$  M6  $\times$ 35 mm. **Total: 4.**
  - d)  $4 \times$  Part-10025-lateral security locking. Each part requires the following fasteners:
    - i.  $2 \times$  M6 $\times$ 25 mm. **Total: 8.**
    - ii. stud:  $1 \times$  CSN02 1187 M6 $\times$ 30 mm. **Total: 4; missing\***.

#### 4 Hanging the mirror

- iii. lock nut: 1×UNI EN 24032 M6. **Total: 4; missing\***.
- e) 4×Part-10023-clamp intermediate mass. Each part requires:
  - i. 2 ×M6 ×25 mm. **Total: 8.**
  - ii. stud: 1×CSN02 1187 M6 ×30 mm. **Total: 4; missing\***.
  - iii. lock nut: 1×UNI EN 24032 M6. **Total: 4; missing\***.

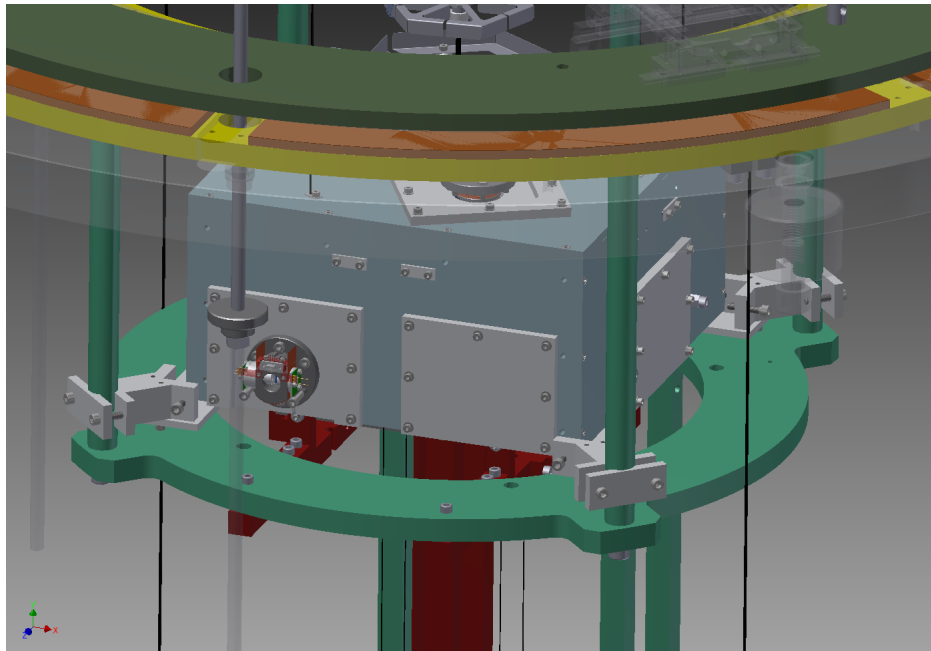

3. Place the earthquake stop ring for the IM on the frame. Set it in position using 8 pins which have to be inserted on the frame (item 3 in Sec. 3).

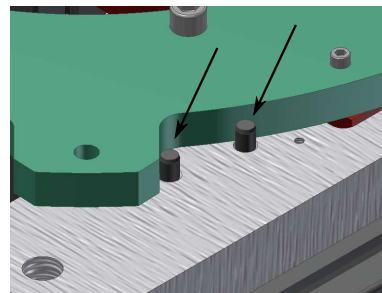
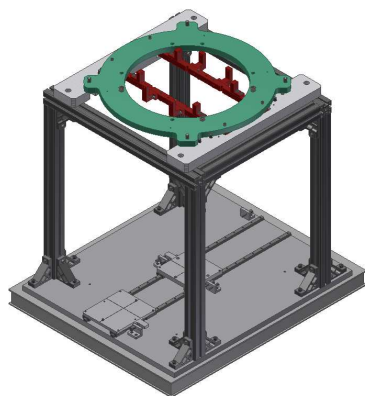

4. Secure the earthquake stop to the frame with two C-clamps as shown in the cross section view.

#### 4 Hanging the mirror

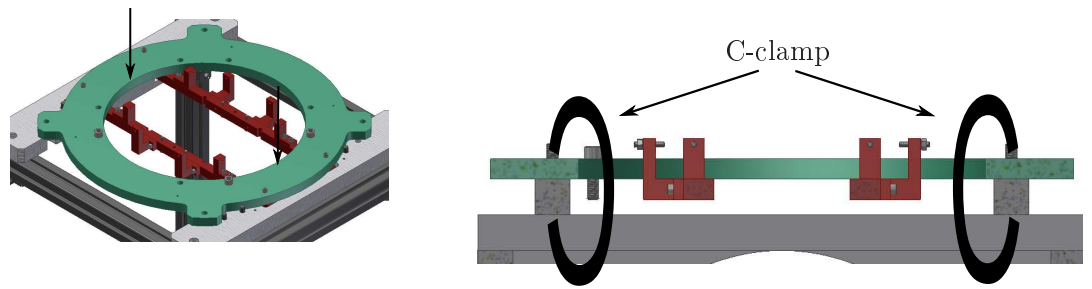

5. Place the IM on top of the earthquake stop. The wire clamps should face the sides of the frame and not to the front or back. Note that since the frame seems to be symmetric (it looks the same whether it's seen from the front or the back), the direction (front or back) from which the optic and RM are inserted will be determined by the orientation of the IM selected now.

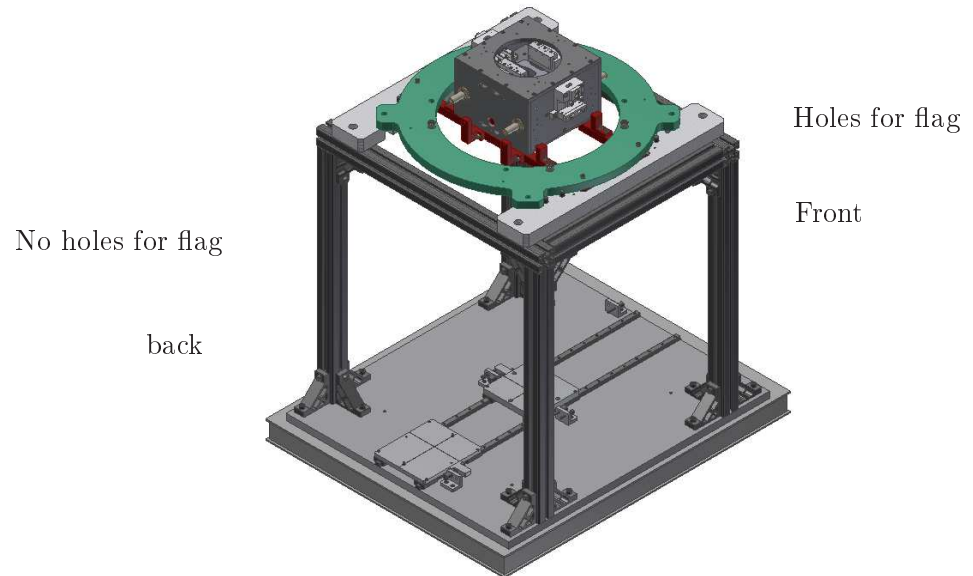

6. Secure the IM to the earthquake stop with the following fasteners:

- Screws:  $4 \times M5 \times 45$  mm.
- Washers:  $4 \times M5$  plain washers.

#### 4 Hanging the mirror

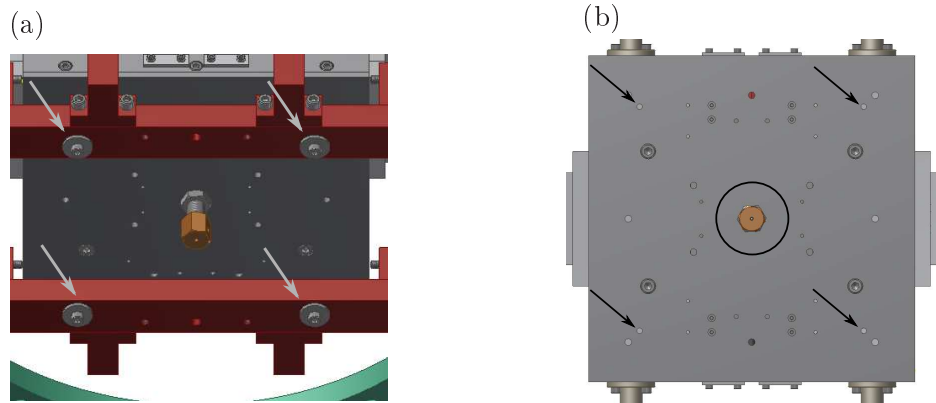

7. Place the winch system on top of the IM. Secure it with the following screws: 4 × ISO 4762 M5 × 30 mm. Remove any peek cable clamp from the top of the IM and move the cables out of the way.

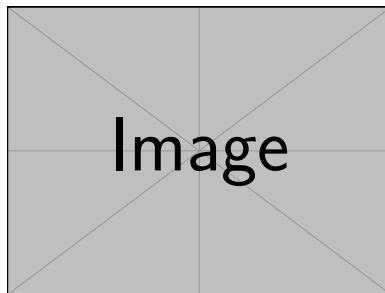

8. Place the bubble level on top of the IM. (The diagram has to be updated.)

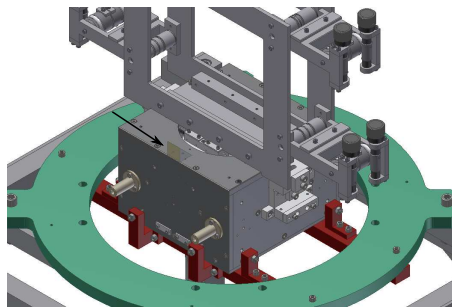

9. Release the fasteners tightened in step 6. Adjust the tilt of the IM using the bubble level. Loosen the screws with the washers and adjust the tilt with the four full-threaded screws which are inserted into the crossed beams of the earthquake stop. Once the IM is straight, fasten the screws with the washers to fix it in position.



#### 4 Hanging the mirror

The IM must be 2 mm above the earthquake stop plate and 22 mm above the crossbeam. Use a caliper to measure these quantities. The height of the IM from the base of the frame should be 786 mm. Use a height gauge to measure it. Also check yaw. The full-threaded screws are ISO4762 M6×70 mm. These screws will not remain with the payload within the vacuum chamber during operation.

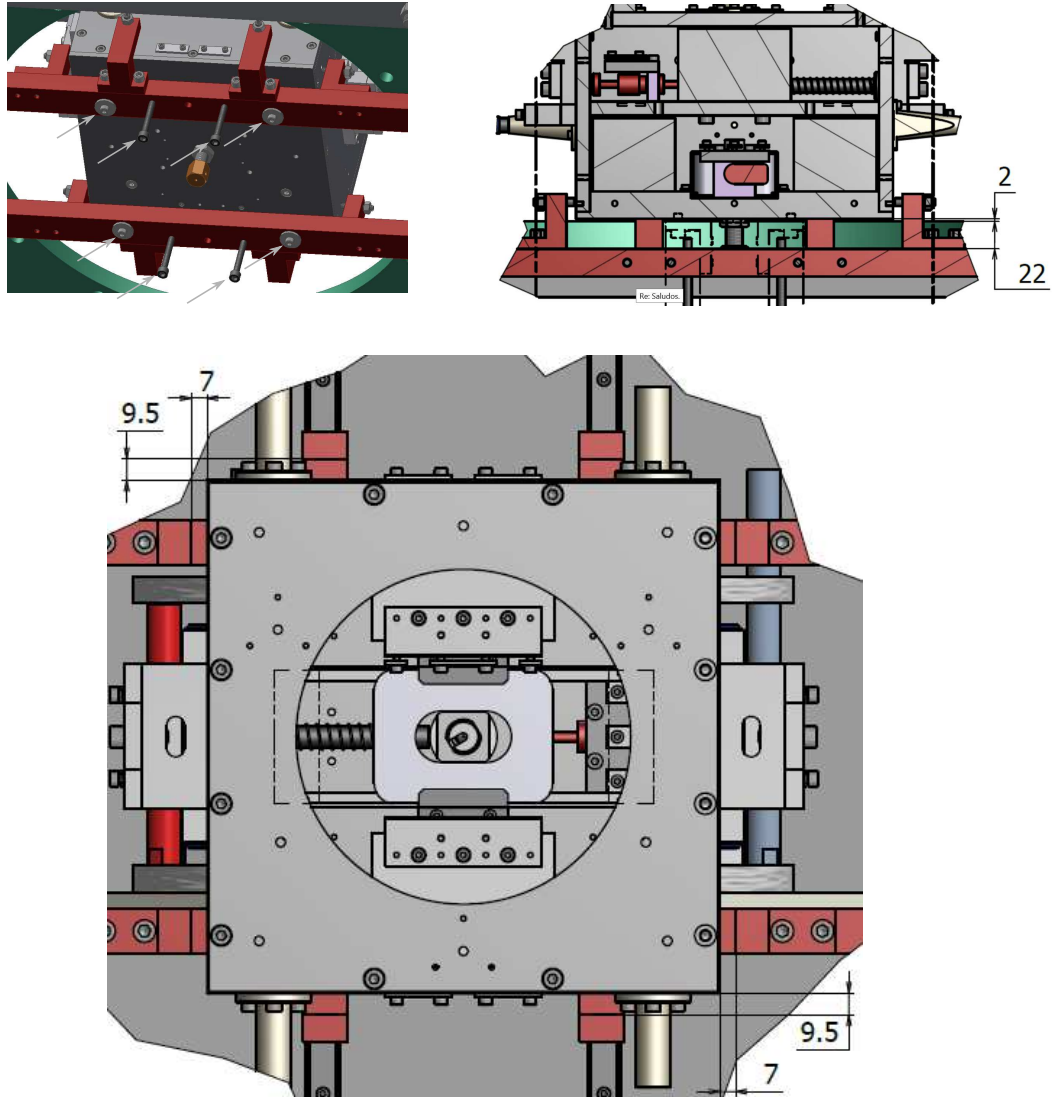

10. Hang a plumb-bob from the magnetic damper holder at the bottom of the IM. Slide the base of the mirror support under the IM and place its center where the plumb-bob indicates. Fix it in place with the screws on the sides.

#### 4 Hanging the mirror

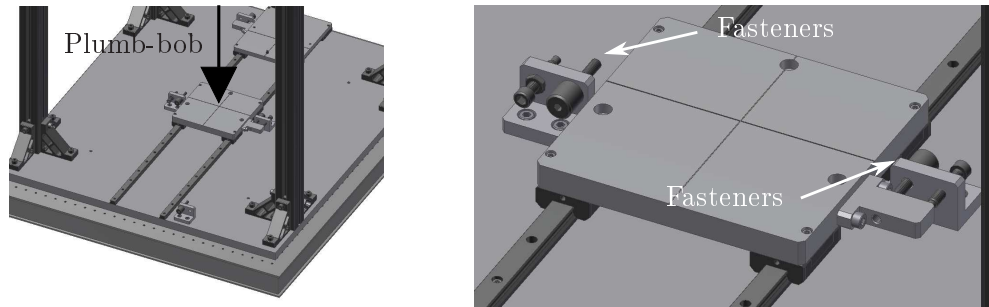

11. Place the case with the mirror inside on the table on the support placed under the IM in the previous step. There are screws to fasten it to the support (the holes are shown in the second drawing in step 10).

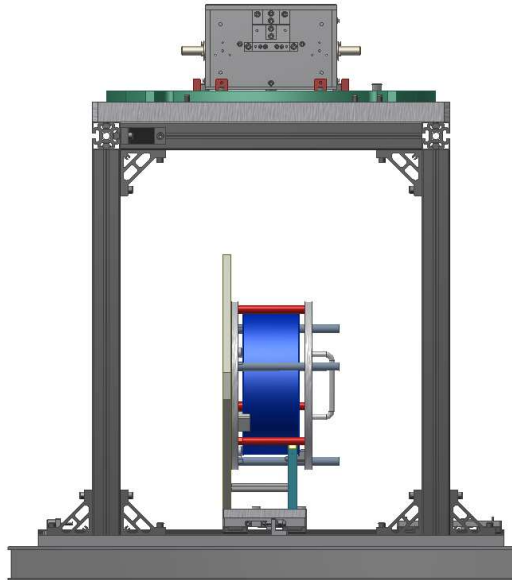

12. Cut two pieces of 2.5 m of 200  $\mu\text{m}$  of piano wire.
13. Wipe the wires with solvents. LIGO used methanol, then acetone and finally isopropanol.
14. Bring one end of each wire underneath the mirror through the hole in the case.

#### 4 Hanging the mirror

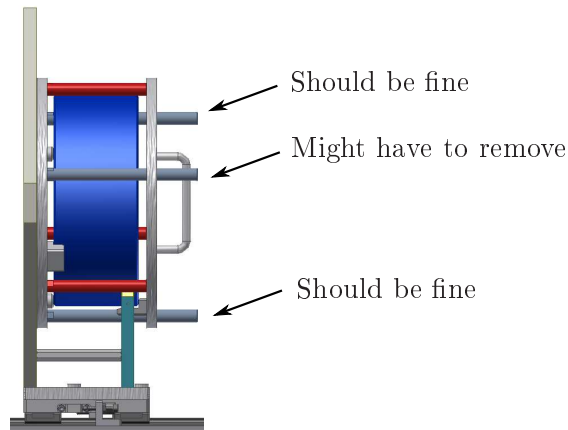

15. Bring the wires through the slits in the clamps all the way up to the winches. One of the gray rods might be on the way of the wires, please remove it. The clamps should already be on the IM. There is a separate manual for it. In case they are not please use the following fasteners:

- a) 2×ISO 4762 M6×35 mm screws uncoated for the upper holes.
- b) 2×ISO 4762 M6×16 mm screws uncoated for the lower holes.
- c) 2×pin20mm\_IS02338B locating pins.

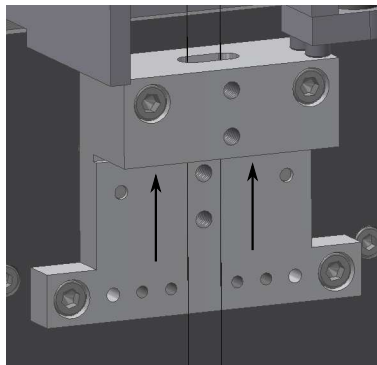

16. Fold the wires over the winch roller with the grooves and bring them to the roller with the clamp and fix them. Clamps referred to as *A* in the figure have grooves on the round face which can be used to host the wires. In order to do this operation more comfortably it is possible to use an auxiliary flat clamp between the two rollers, but release it once the wires are fixed. Such flat clamp is not shown in the figure, but its place is indicated by holes *B* and *C*. Rotate the roller to wind the wire at least one loop. This is to avoid cutting the wire with the clamp. There is

#### 4 Hanging the mirror

at least one person in each group who has used the winches before. (Pictures taken from the e-log entry at <http://www2.nao.ac.jp/~gw-eelog/os1/?r=184.>)

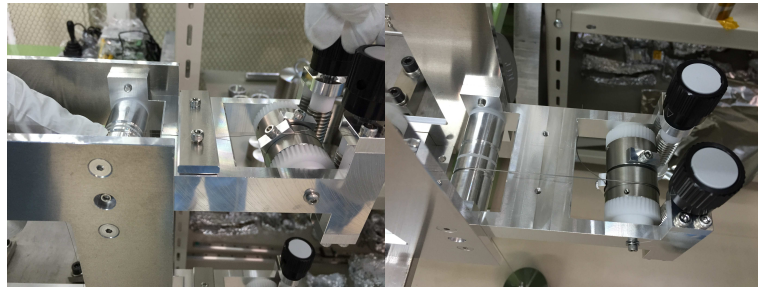
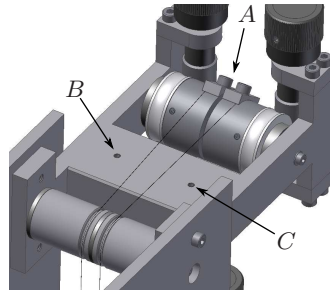

17. Create tension in the pair of wires by pulling them down from below the clamp assembly in the IM and then **softly** fix them with the upper clamp without the vertical grooves. Use  $2 \times$  ISO 4762 M6 $\times$ 16 mm coated screws.

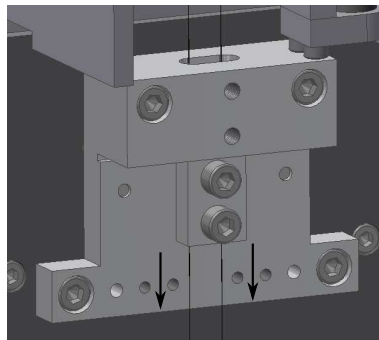

18. At the other side of the payload bring the other two ends of the wires up through the slit in the clamp all the way to the winches.

#### 4 Hanging the mirror

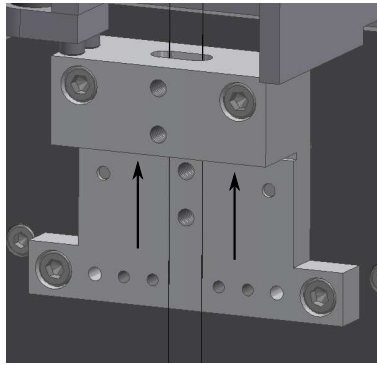

19. As in step 16, fold the wires over the winch roller. Before clamping them create tension by pulling them and making sure they go within the grooves of the four wire breakers around the TM. The figure shows one wire breaker and the grooves are clearly seen. Note that in reality the glass beads are not as neatly placed as depicted.

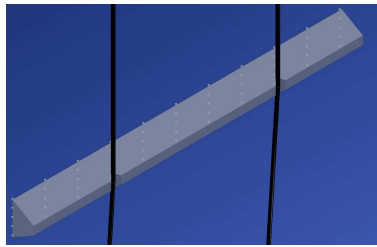

20. Remove or retract any components of the case that would keep the mirror from being lifted slightly. Some of the components don't seem to be removable, but others do. (The model does not have OSEM flags or wire breakers. I has to be updated.)

#### 4 Hanging the mirror

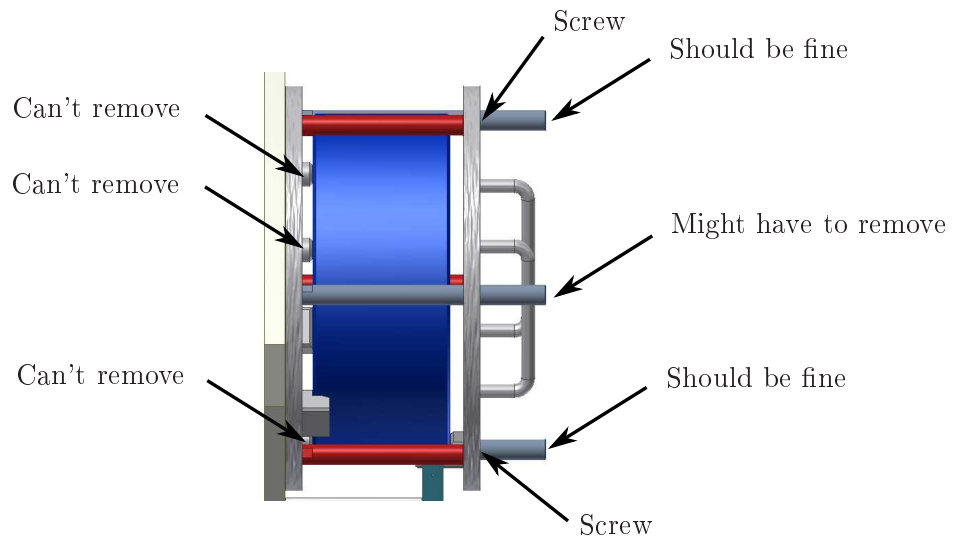

21. Release the clamp adjusted in step 17.
22. Lift the mirror slightly with the wires. Do not go very far up. Move the case to make the optic hang completely free. This will allow us to lift the mirror further and to align it. (The model does not have OSEM flags or wire breakers. I has to be updated.)

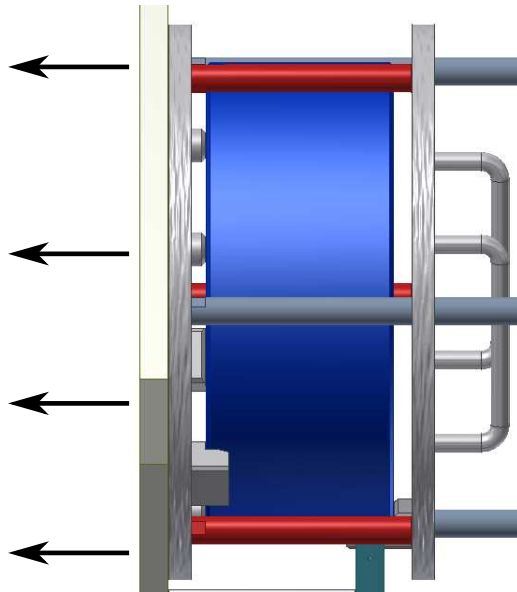

23. Use the four upper knobs to lift the optic 3 mm from their resting position on the support. The height of the wire breakers must be 251 mm after lifting. Use a height gauge. (The model has to be updated.)

#### 4 Hanging the mirror

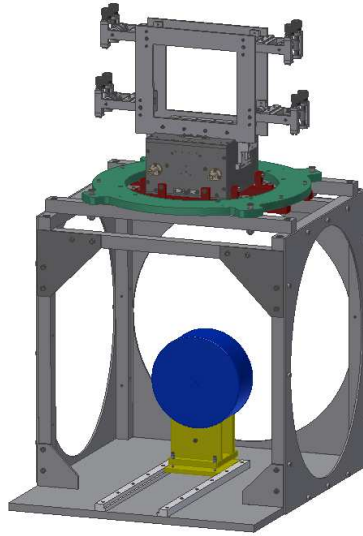

24. Using the knobs also, align the optic with the optical lever.
25. Once the TM is aligned close the lower clamps, which have grooves. Make sure the wires are held within the grooves. Do this on both sides of the IM. **These clamps should not be tightened. They should only be closed gently.** The intention is to produce an elastic deformation of the wires. Use a torque wrench with a [TBD](#) torque spec. Use the follwig fasteners:
  - a) 2×ISO 4762 M4×20 mm screws coated,
  - b) spring washer: 2×M4<sup>1</sup>,
  - c) locating pins: 2×pin12mm\_IS02338B.

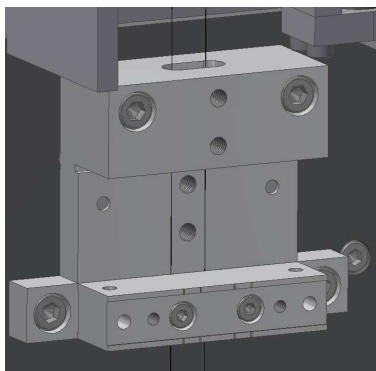

---

<sup>1</sup>spring\_washer\_M4\_typeA

#### 4 Hanging the mirror

26. Check whether the alignment of the TM changed. In case it did, release the clamps and go back to step 24. Otherwise continue to the next step.
27. Tighten the upper clamps on both sides of the IM. These clamps do not have grooves. The aim is to produce a plastic deformation of the wires in order to hold the mirror. Use the same screws as in step 17.

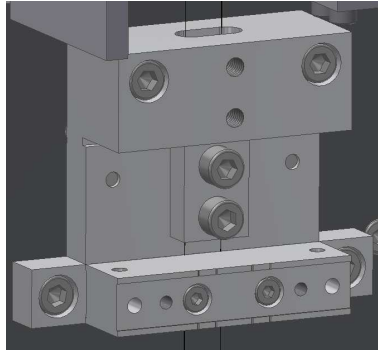

28. Remove whatever is necessary from around the optic in order to bring the RM around it. Put back any gray rod that could have been removed if possible. They are guides to remove the side plate. (The diagram below has to be updated.)

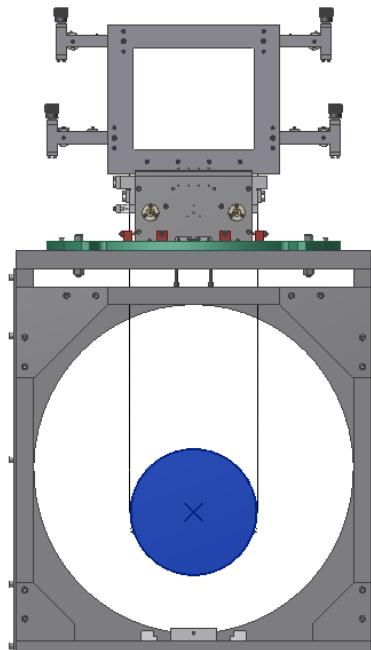

29. Using the gray rods remove the side plate without damaging the OSEM flags.



#### 4 Hanging the mirror

30. Place the RM with its support on the rails. Adjust the height of the wire breakers to 251 mm above the table with the height gauge.

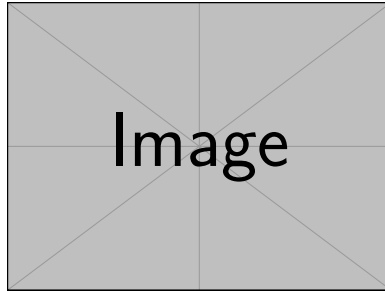

31. Bring the RM as close as possible to the optic without removing the protective case of the optic. Coarsely set the tilt of the RM by adjusting the screws at the base of the support of the RM. A bubble level can be placed on the multipurpose cube. By visual inspection align the OSEM cavities with the flags on the optic.

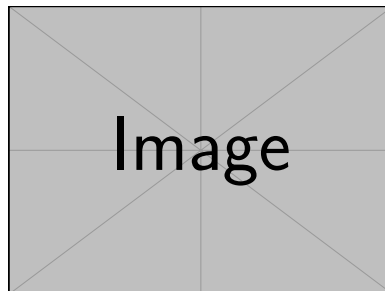

32. Connect the OSEMs to the satellite boxes and obtain a suitable readout. Ideally this should be the digital system. Have the calibration curves of the OSEM ready for inspection. For the test procedure at Kamioka we don't have calibration curves since we're using the prototype satellite boxes from TAMA300. Just check the open voltage output and record it in the log.

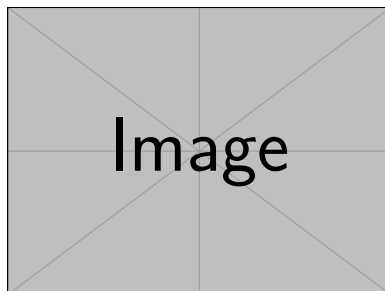

33. Bring the RM around the optic until one or more OSEMs deliver approximately the output expected at the nominal position of the flags. Such voltage would typically be half of the open voltage.

#### 4 Hanging the mirror

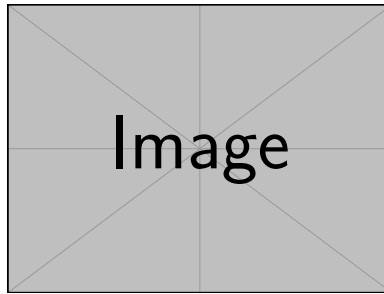

34. Close the RM with the front ring. Use the following fasteners: 12×ISO 4762 M5×40. Coated.
35. Insert the earthquake stop screws assemblies in step Do not screw the earthquake stop screws all the way in.

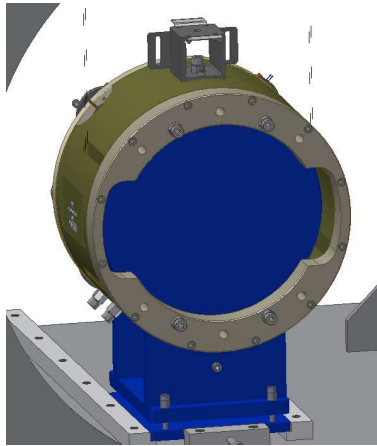

36. Clamp the OSEM ribbon cables on the RM back ring, on the multipurpose cube on top and on the sides of the IM. Use stainless steel clips for the multipurpose cube. From the IM the cables will likely need another temporary anchor point before being connected to the satellite boxes.
37. Cut 2.5 m of 600  $\mu\text{m}$  tungsten wire. We can also try the 650 tungsten  $\mu\text{m}$  wire should the wire breaker allow. (I still have to check whether the wire breaker receives it.)
38. Bring the ends of the wires underneath the RM through the hole in the pedestal.

#### 4 Hanging the mirror

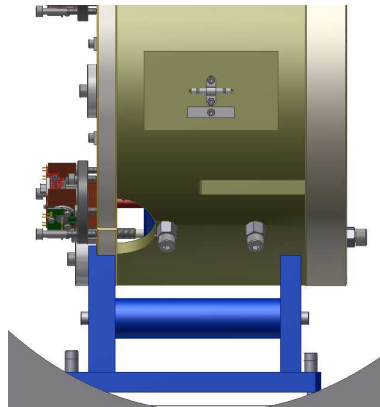

39. On one side of the payload bring the wires in front of the clamps on the IM all the way up to the winches.

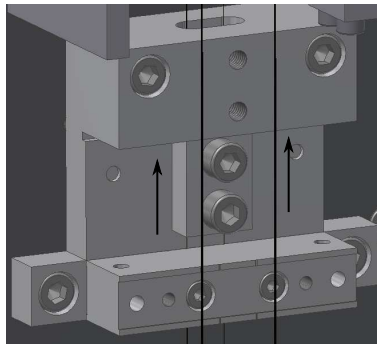

40. Fold the wires over the winch roller with the grooves and bring them to the roller with the clamp and fix them. Use the clamp between the two rollers if necessary but release it once the wire is fixed.

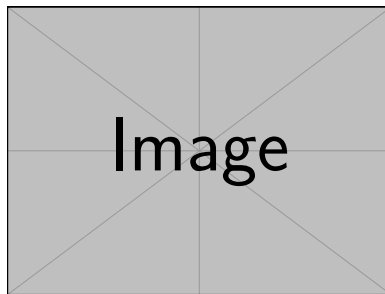

41. Create tension in the pair of wires by pulling them down from below the clamp assembly in the IM and then gently fix them with the upper flat clamp without the vertical grooves. The function of the clamp at this stage is only to keep the tension of the wire above the clamp.

#### 4 Hanging the mirror

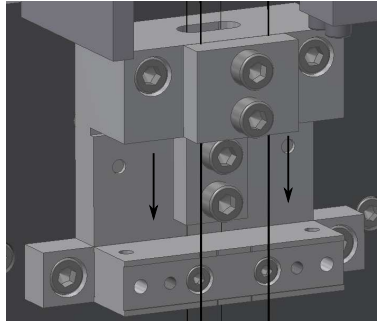

42. At the other side of the payload bring the wires all the way to the winches.

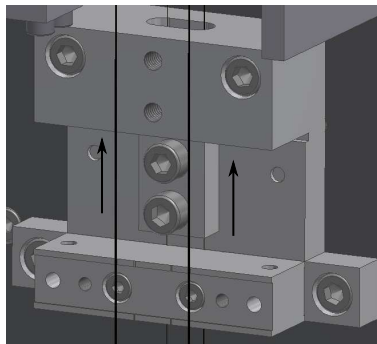

43. Fold the wires over the winch roller with the grooves and bring them to the roller with the clamp. Create tension by pulling the wires up, but not enough that would lift the RM. Make sure the wires go within the grooves of the two wire breakers around the RM. Fix the wires onto the roller with the clamps. Use the flat clamp in between the two rollers if necessary.

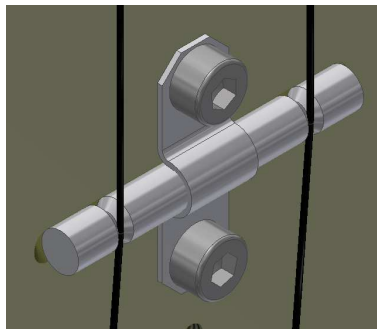

44. Remove any components of the RM support that would keep it from hanging. (As far as I understand, in the current design there is nothing of this sort.)

#### 4 Hanging the mirror

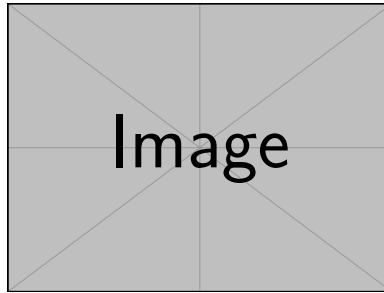

45. Place bubble level on top of the multipurpose cube.

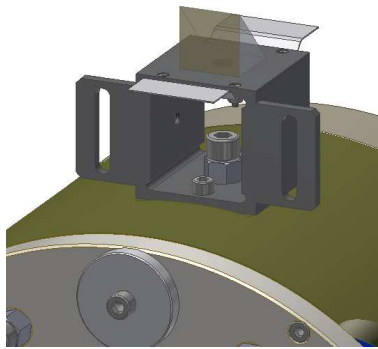

46. Release the clamp adjusted in step 41.
47. Bring down the RM support slowly. Do it while looking at the positions of the flags within the OSEMs. The flags should not come close to the OSEM body. If the RM still comes down with the support increase the tension in the wires by adjusting the knobs of the winches. Bring down the support until the RM hangs.

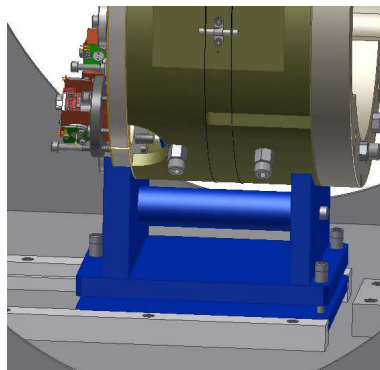

48. Using the knobs align the RM with the optical lever using the reflection on the prism. Do this first in pitch and then in roll by rotating the right angle prism 90

#### 4 Hanging the mirror

degrees.

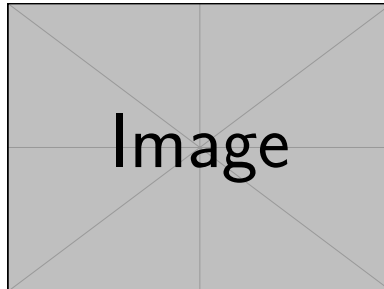

49. Measure again the height of the wire breakers. It should be 251 mm.
50. Close the lower clamps, which have grooves, in order to fix the wires in position (20 mm separation). **These clamps should not be tightened strongly, but gently in order to produce an elastic deformation.** [Torque spec TBD](#). Use the following fasteners:
  - a) 2×ISO 4762 M4×25 mm coated.
  - b) spring washer: 2×M4<sup>2</sup>,
  - c) locating pins: 2×pin12mm\_ISO2338B.

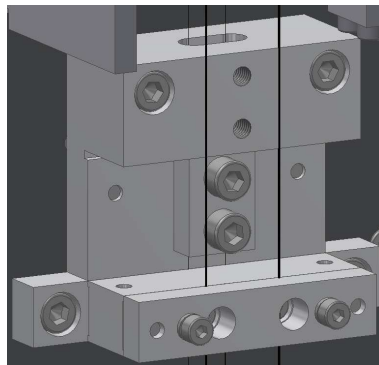

51. Check whether the alignment of the TM changed. In case it did, release the clamps and go back to step 47. Otherwise, continue to the next step.
52. Tighten the upper clamps on both clamp assemblies. [Torque spec TBD](#). These clamps do not have grooves. These clamps are meant to hold the weight of the RM and a plastic deformation of the wires should be achieved. Use the following screws per assembly: 2×ISO 4762 M6×20 mm.

---

<sup>2</sup>spring\_washer\_M4\_typeA

#### 4 Hanging the mirror

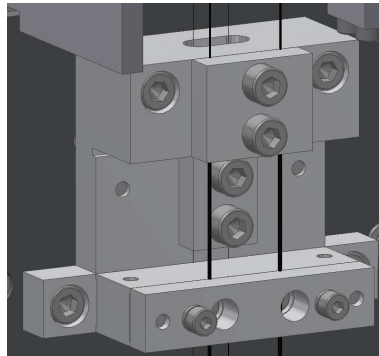

53. Check the output of the OSEMs. Provided the OSEMs were aligned and set at the correct position with respect to the RM, the flags should be close to their nominal positions and the output voltage should be close to 6 V. If they are not then either the OSEMs were not aligned when mounted on the RM or the RM is not aligned with respect to the TM. In the first case please align the OSEMs individually. This may be hard without the lower section of the earthquake stop around the RM. So, the earthquake stop should be assembled now before realignment of the OSEM.
54. The wires can be cut and the winch system can be removed.
55. In case the lower section of the earthquake stop was not assembled in step 53, assemble it now.