

bKAGRA PSL Design Study

Yuta Michimura

Department of Physics, University of Tokyo

Scope

- Collect information for bKAGRA PSL
- Give first proposal for bKAGRA PSL design
- Start discussion on noises and control loops
PMC, FSS, ISS
- References:
 - [JGW-G1503293](#), [JGW-G1402866](#) (laser setup)
 - [JGW-T1402349](#) (iKAGRA PMC)
 - [JGW-G1503515](#) (bKAGRA PMC)
 - [JGW-T1503330](#) (FSS modeling)
 - [JGW-D1503389](#) (ISS plan)
 - [JGW-D1503189](#) (EOM layout plan)
 - [JGW-T1402332](#) (beam jitter requirement at PSL)
 - [LIGO-T0900649](#) (aLIGO PSL Final Design)
 - N. Ohmae, PhD Thesis (2010)

Schematics

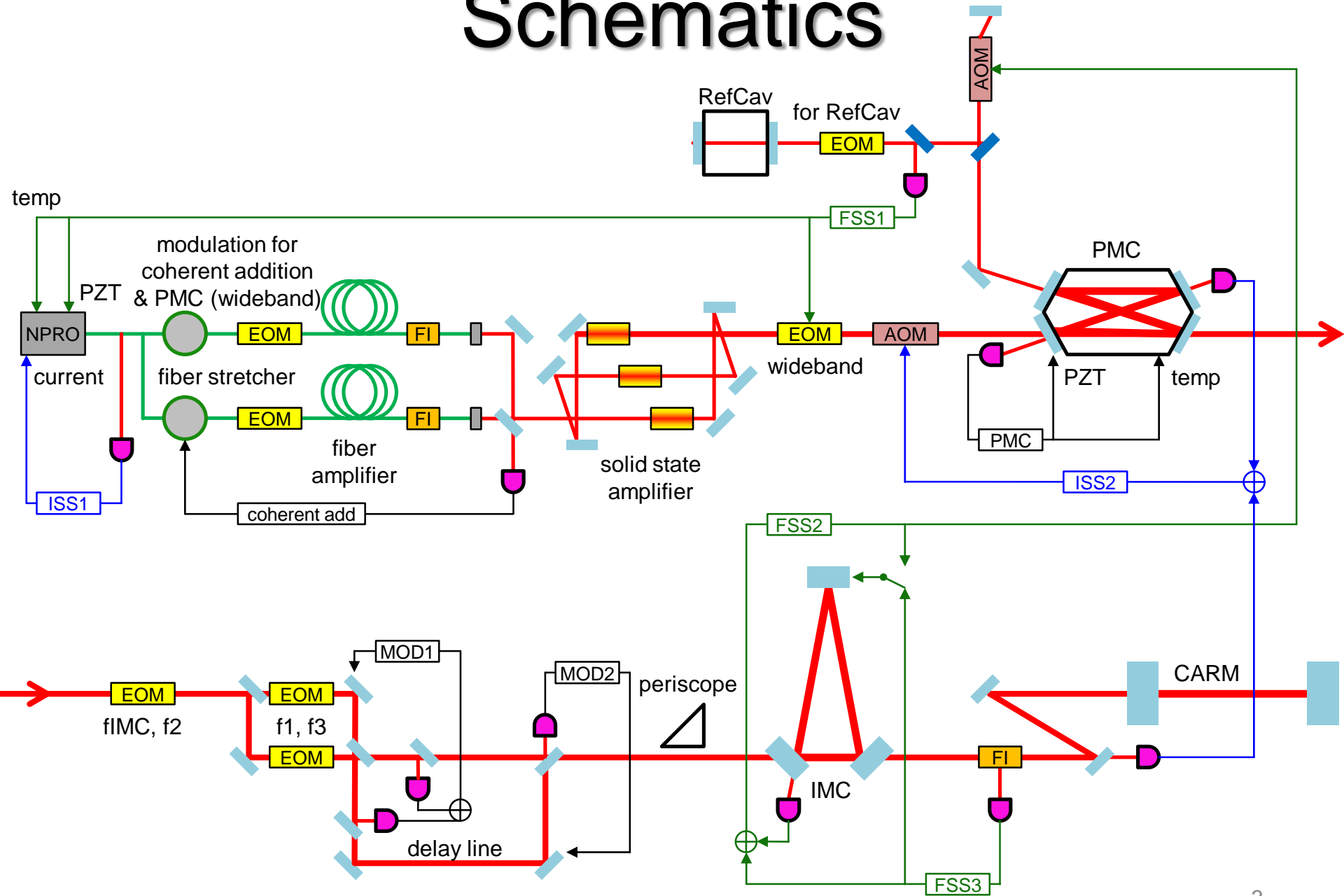

Concept

- RefCav after PMC to reduce beam jitter
 - > wideband EOM after fiber amplifier to avoid phase delay
(Another possibility is to put RefCav and wideband EOM both before the fiber amplifiers. In this case, we don't have to use high power wideband EOM, and RefCav servo stay locked when PMC is unlocked. However, beam jitter might be a problem.)
- Use PMC auxiliary transmissions for RefCav and ISS to save power
- Simple, but loss less f1(PM-AM), f2(PM), f3(AM) modulation
 - > PM-AM switchable for f1
loses some f3 AM, but doesn't matter much
since f3 AM is used only for the lock acquisition
- Use less EOMs as possible
 - > use same EOM for coherent addition and PMC servo
 - use same EOM (doubly-resonant) for f2 and IMC
 - use same EOM (doubly-resonant) for f1 and f2

Actual Layout

- all fit in 4.8 m x 1.5 m bKAGRA PSL table
- see [JGW-D1503484](https://www.jgw-d1503484) for the updated layout

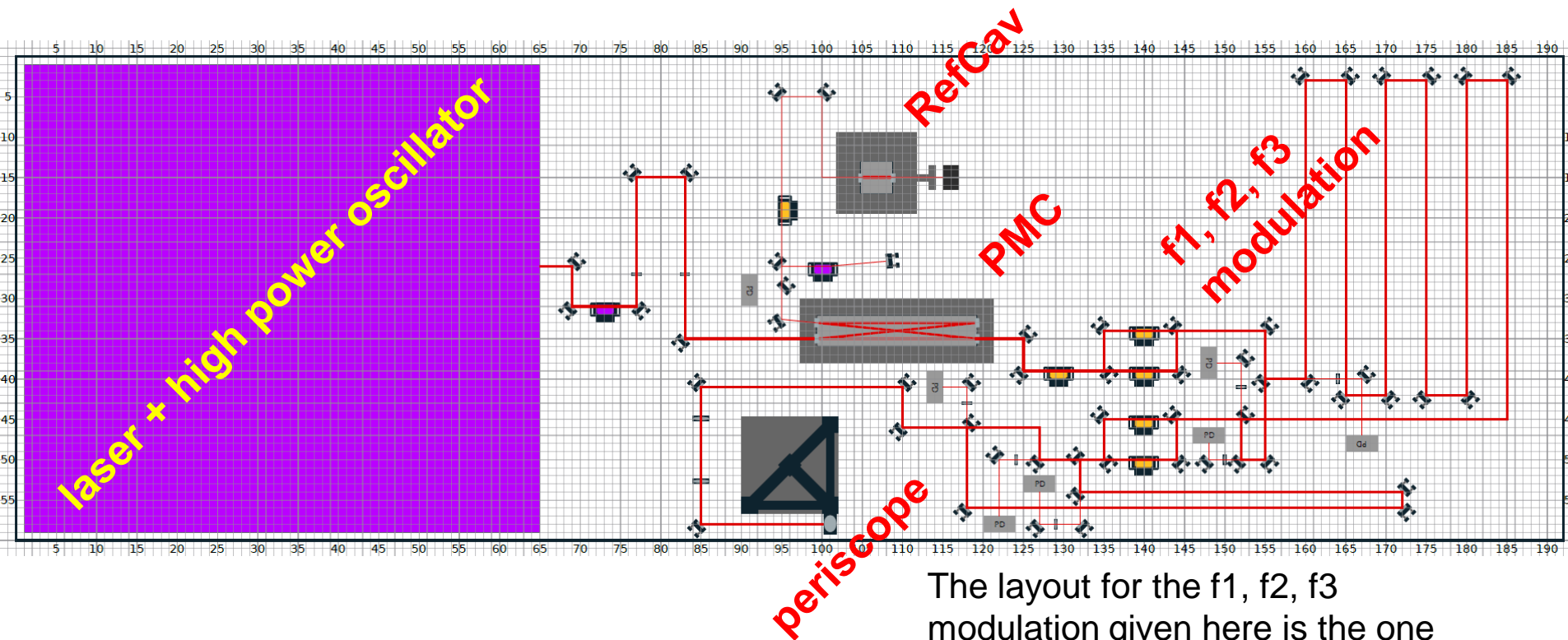

The layout for the f1, f2, f3 modulation given here is the one which takes up the most space. We are thinking of using a different layout as given in p.3

Pre-Mode Cleaner

- bow-tie cavity, aluminum spacer (aLIGO-like)
- at design phase (see [JGW-G1503515](#))

| | |
|-------------------|---------|
| finesse | 155 |
| round trip length | 2.02 m |
| FSR | 150 MHz |
| cavity pole | 480 kHz |
| TMS | 42 MHz |

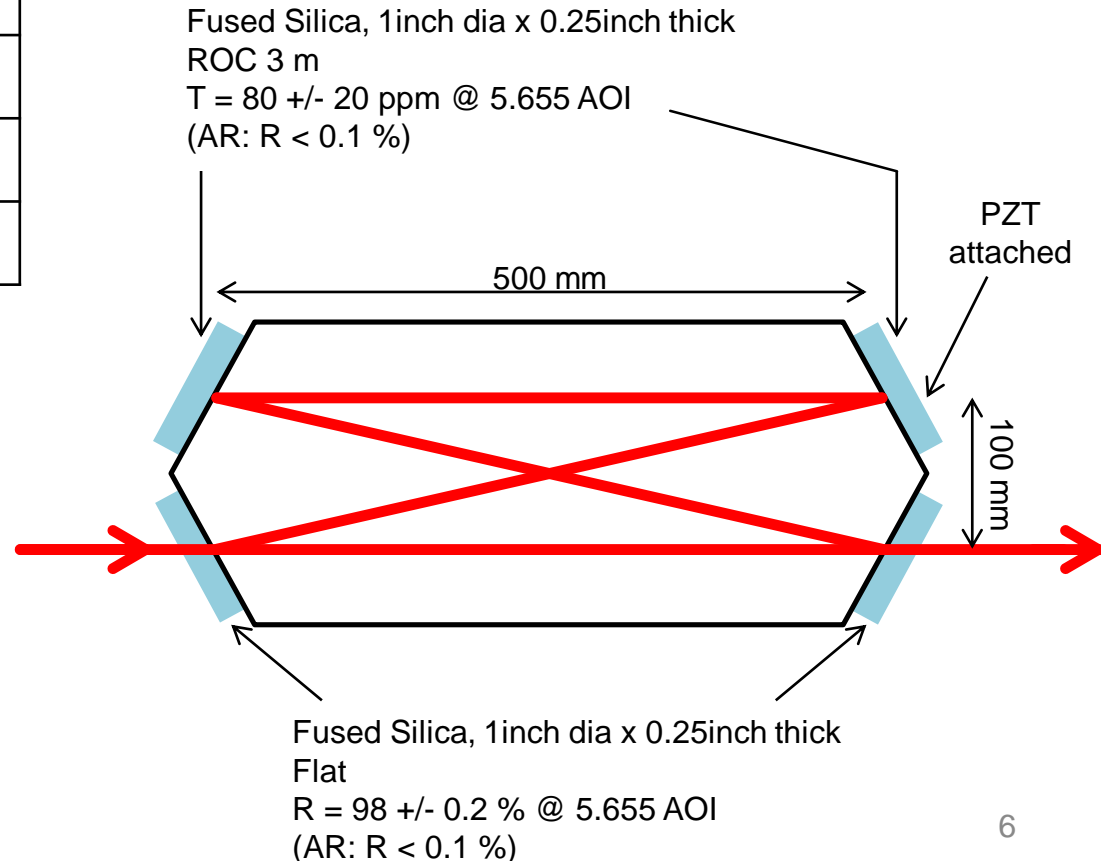

FSR: free spectral range
TMS: transverse mode spacing

Reference Cavity

- linear cavity, ULE spacer
- already made (currently at Kashiwa) including Zerodur support, thermally insulated vacuum can, temperature control
- Specs sheet available from [JGW-T1503493](#)

| | |
|-------------------|----------|
| finesse | 3e4 |
| round trip length | 2*100 mm |
| FSR | 1.5 GHz |
| cavity pole | 22 kHz |
| TMS | 0.11 GHz |

- we call it a RefCav or FRC (frequency reference cavity; it stands for fiber ring cavity in iKAGRA!)

Photo from N. Ohmae



RefCav Frequency Stability

- long term drift should be smaller than $\sim 100 \text{ mHz/sec}$
It corresponds to 8.4 kHz/day and the daily drift will be smaller than the arm cavity FSR (50 kHz). So, we can lock the arm cavity at the same fringe every day.
- this can be achieved by stabilizing the temperature within $\pm 1 \text{ K}$ at the thermal expansion zero crossing point (this gives $< 2e-9 /\text{K}$ of the thermal expansion), and making the temperature drift smaller than $2e-7 \text{ K/sec}$.

- estimated frequency stability is shown right
 seismic: $1e-9 (1\text{Hz}/\text{freq})^{**2} \text{ m}/\text{rtHz}$
 vibration sensitivity: $3e-8$
 vibration isolation: $1x \text{ Minus K}$
 thermal expansion: $2e-9$
 cavity temperature: $(1\text{Hz}/\text{freq}) \text{ uK}/\text{rtHz}$

coating Q: 2500
 substrate Q: $1e6$
 spacer Q: $6e4$
 coating thickness: 10 μm

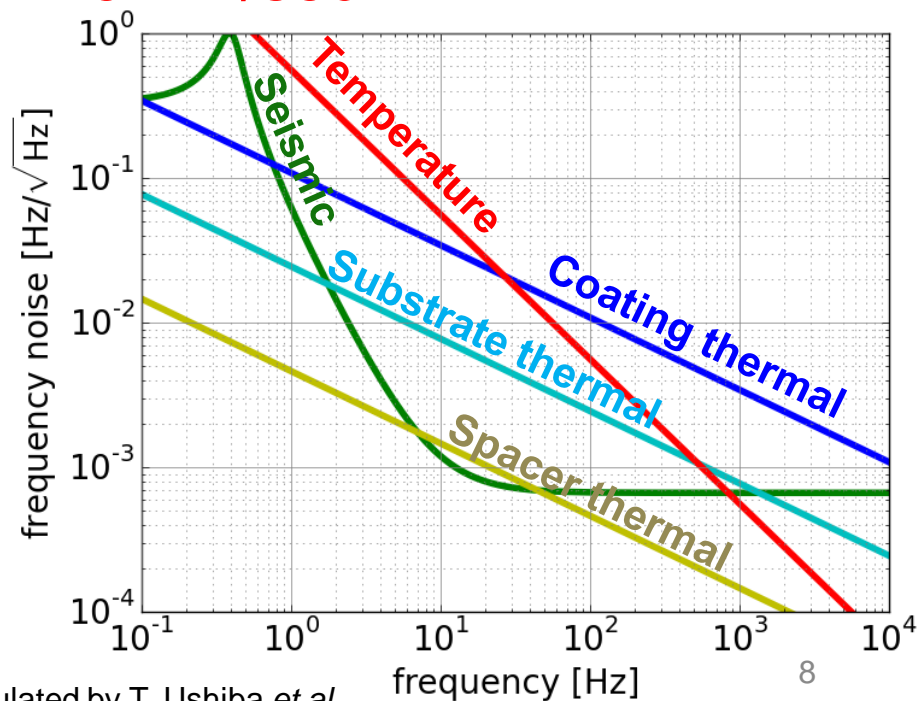

Calculated by T. Ushiba *et al.*

Frequency Stabilization Servo

- Modeling on going
- See [JGW-T1503330](#) for preliminary result
- It looks like the current PSL design basically meet the requirements

Intensity Stabilization Servo

- No modeling yet
- See [JGW-D1503389](#)

EOM Layout for f1 ,f2,f3 Modulations

- Calculation for deciding the layout on going
- See [JGW-D1503189](#)
(we are considering of choosing layout 3)
- Sideband amplitudes we need
 - f1 PM: $J_1(0.15)$ [$J_1(0.2)$ at maximum]
 - f1 AM: $0.65 * J_1(0.15)$ [optional for DRSE; 65% of PM]
 - f2 PM: $J_1(0.05)$ [$J_1(0.1)$ at maximum]
 - f3 AM: 0.05 [only used for lock acquisition]
- Unwanted sidebands
 - f1 harmonics: requirements to be calculated
 - f3 harmonics: requirements to be calculated
 - unwanted f1 AM: requirements to be calculated
 - unwanted f2 AM: requirements to be calculated

Beam Jitter

- Requirements for PSL periscope mirror displacement/tilt are

$$\delta x < (5 \times 10^{-10} + 5 \times 10^{-3} \text{ Hz}/f^4) \text{ m}/\sqrt{\text{Hz}}$$

$$\delta \theta < (2 \times 10^{-11} + 2 \times 10^{-4} \text{ Hz}/f^4) \text{ rad}/\sqrt{\text{Hz}}$$

(see [JGW-T1402332](#) for derivation)

- We have to design a periscope to meet this requirement

People in Charge

- Overall layout [Nakano]
- PMC [Nakano, Michimura, UToyama]
- RefCav [Michimura?]
- FSS [Michimura]
- ISS [UToyama]
- EOM [Uehara, Shiga, Somiya]
- Periscope [??]