

OSEM to Sat Amp Cabling JGW-T1403037-v2, 20 Feb 2015, as agreed between Fabian, Mark, Sekiguchi, Takahashi and Miyakawa. Modified from -v1 to make better use of twisted pairs in the standard out-of-vacuum cable (D1402377).

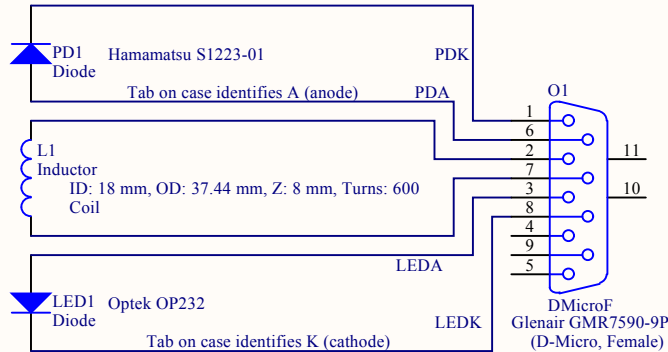

OSEM

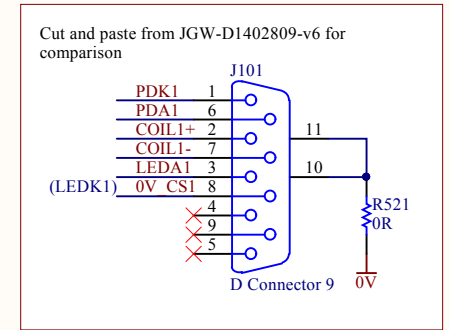
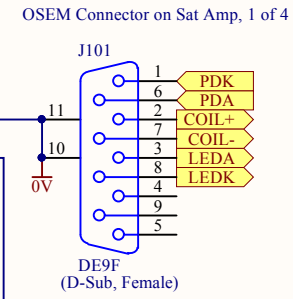
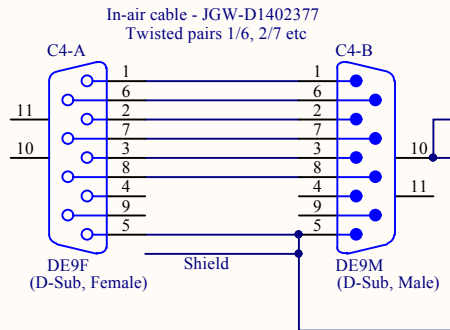
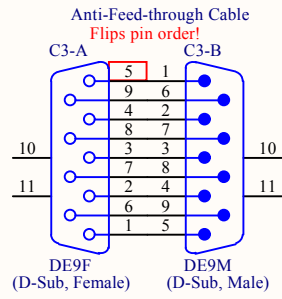
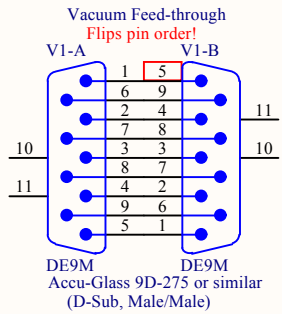
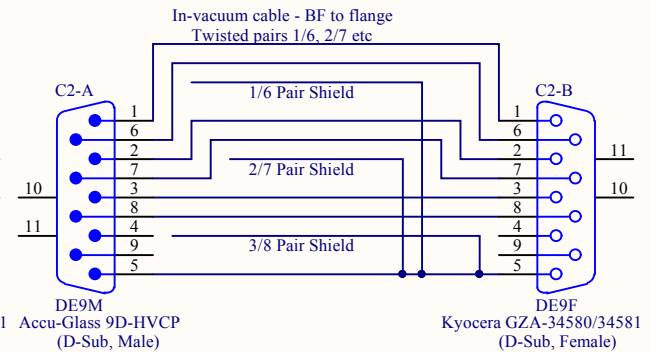
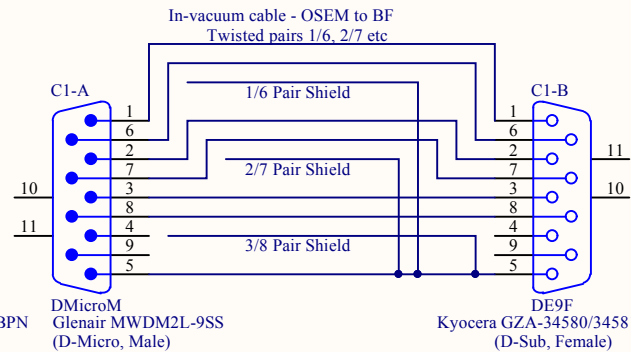

Title			
OSEM to Sat Amp Cabling			
Size	Number	Revision	
A4	JGW-T1403037	-v2	
Date:	1 2015/02/20	Sheet 1 of	1
File:	\\.\OSEM cabling.SchDoc	Drawn By:	Mark Barton