

Requirements for IMC Mirror Placement

Yuta Michimura

Ando Group

Department of Physics, University of Tokyo

Scope

- Set the requirement for placement errors for input mode cleaner (IMC) mirrors.
- References:
 - [J. Opt. 13 055504 \(2011\)](#)
(triangular cavity eigenmode paper by Kawazoe)
 - [JGW-T1402481](#) (calculation by T. Saito)
 - [JGW-D1402507](#) (IOO 3D drawing)
 - [JGW-T1402486](#) (layout around IFI)

Conclusion

- M_{Ci} placement error should be
yaw < 1 deg, pitch < 1 deg, disp < 1 mm
- M_{Co} placement error should be
yaw < 0.5 deg, pitch < 1 deg, disp < 1 mm
- M_{Ce} placement error should be
yaw < 0.5 deg, pitch < 1 deg, disp < 1 cm

- Angular requirements are from actuation range (alignment should be done within ~0.1 mrad to get the beam resonating in the cavity).
- Displacement requirements are from beam displacements at succeeding mirrors/viewports.

Requirement 1

- The beam should hit the IMC mirrors.

Definitions

- α/β for yaw/pitch misalignment
- γ for longitudinal displacement

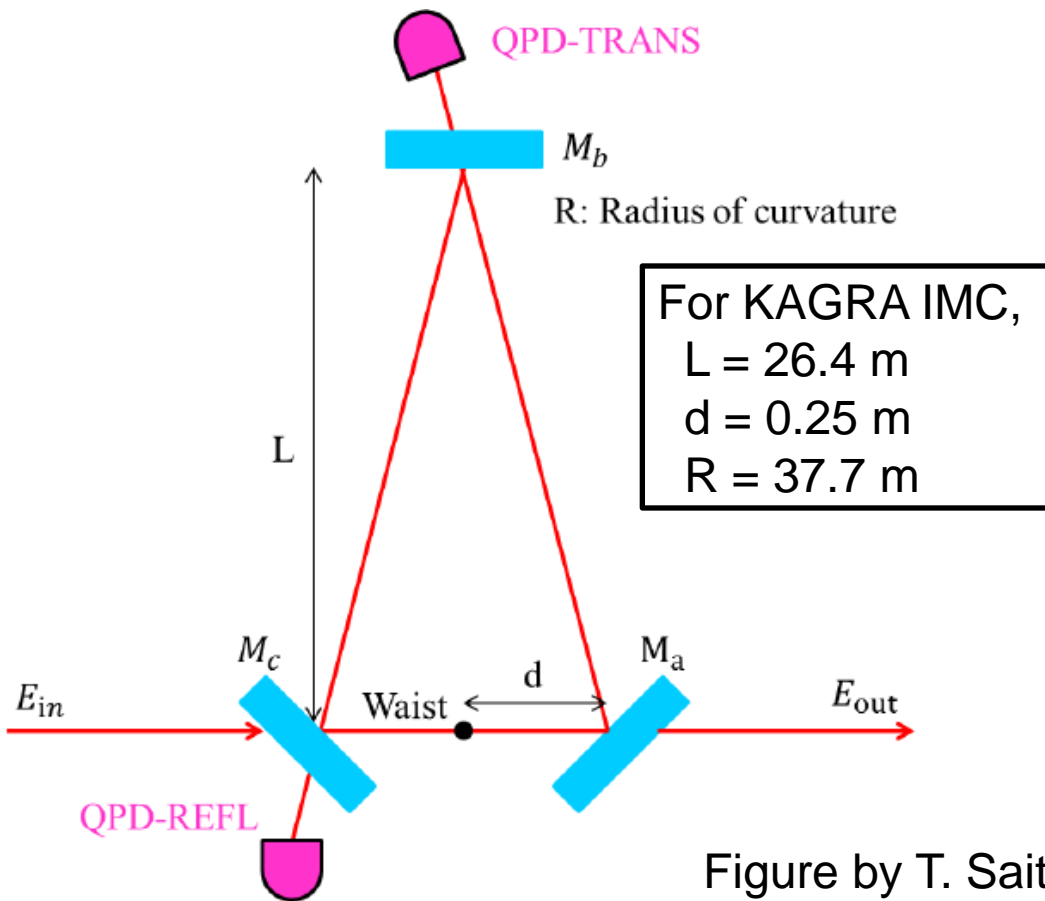

Fig.1 Input Mode Cleaner

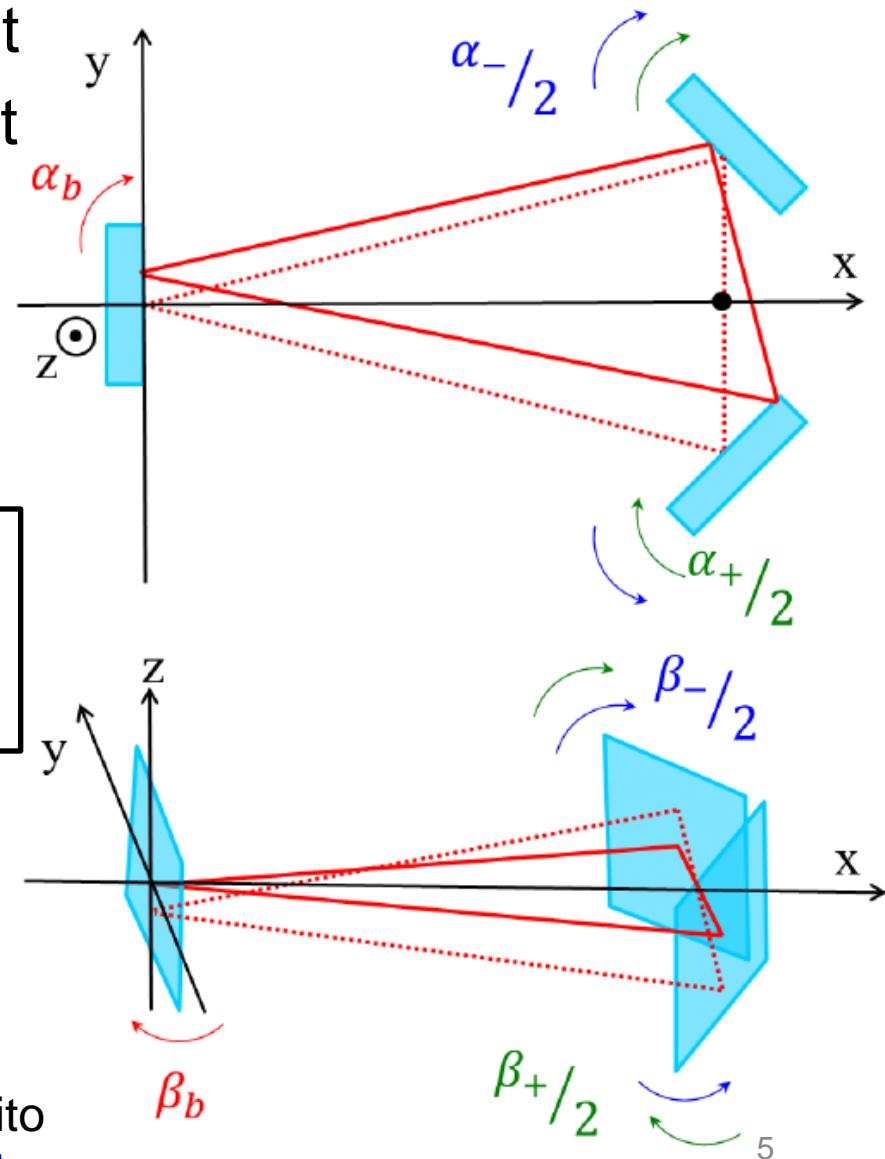

Fig.4.1 ミスアラインメント時の共振器軸の変化

Figure by T. Saito
[JGW-T1402481](https://doi.org/10.1145/JGW-T1402481)

Miscentering from Misalignments

- all values are in m/rad
- $\alpha_b < 0.5$ mrad
- $\alpha_- < 1.5$ mrad
- $\alpha_+ < 50$ mrad
- $\beta_b < 1.5$ mrad
- $\beta_- < 250$ mrad
- $\beta_+ < 1.5$ mrad

	Δr_c (MCi)	Δr_a (MCo)	Δr_b (MCe)
α_b	$\frac{\sqrt{2}Rd}{R-L-d}$ = 1.21	$\frac{\sqrt{2}Rd}{R-L-d}$ = 1.21	$-\frac{R(L+d)}{R-L-d}$ = -90.9
α_-	$\sqrt{2(L^2 + d^2)}$ = 37.3	$-\sqrt{2(L^2 + d^2)}$ = -37.3	0
α_+	$-\frac{\sqrt{2}(R-L)d}{R-L-d}$ = -0.362	$-\frac{\sqrt{2}(R-L)d}{R-L-d}$ = -0.362	$\frac{Rd}{R-L-d}$ = 0.853
β_b	$-R$ = -37.7	$-R$ = -37.7	$-R$ = -37.7
β_-	$\frac{d}{\sqrt{2}}$ = 0.177	$-\frac{d}{\sqrt{2}}$ = -0.177	0
β_+	$\frac{R-L}{\sqrt{2}}$ = 7.99	$\frac{R-L}{\sqrt{2}}$ = 7.99	$\frac{R}{\sqrt{2}}$ = 26.66

Note that miscentering is defined by $\Delta r = \sqrt{(\Delta x)^2 + (\Delta y)^2 + (\Delta z)^2}$, where $\Delta x, \Delta y, \Delta z$ are the displacements defined in [J. Opt. 13 055504 \(2011\)](#).

Miscentering from Displacements

- all values are in m/m
- $\gamma_c < 2$ cm
- $\gamma_a < 2$ cm
- $\gamma_b < 3.5$ cm

	Δr_c (MCI)	Δr_a (MCo)	Δr_b (MCe)
γ_c	0	1	$\frac{R}{\sqrt{2}(R-L-d)}$ = 2.41
γ_a	1	0	$-\frac{R}{\sqrt{2}(R-L-d)}$ = -2.41
γ_b	$\sqrt{2}$	$\sqrt{2}$	0

Summary 1

- If we set the requirement for the beam miscentering to be 5 cm (c.f. mirror diameter = 10 cm);
- M_{Ci} placement error should be
yaw < 0.7 mrad, pitch < 0.7 mrad, disp < 2 cm
- M_{Co} placement error should be
yaw < 0.7 mrad, pitch < 0.7 mrad, disp < 2 cm
- M_{Ce} placement error should be
yaw < 0.5 mrad, pitch < 0.7 mrad, disp < 3.5 cm
(c.f. 1 mrad = 0.06 deg)
- It seems impossible to meet the angular requirements only by placing the optics. Fine adjustment should be done with picomotors on IMC suspensions.
→ angular requirement should be set from actuation range
- The displacement requirements seem to be too easy from other point of view.

Requirement 2

- IMC transmitted beams should hit the succeeding optics.
- IMC incident beam path and oplev beam paths should be clear.

IMC layout

to IMC TRANS PDs

* Not to scale at all !!

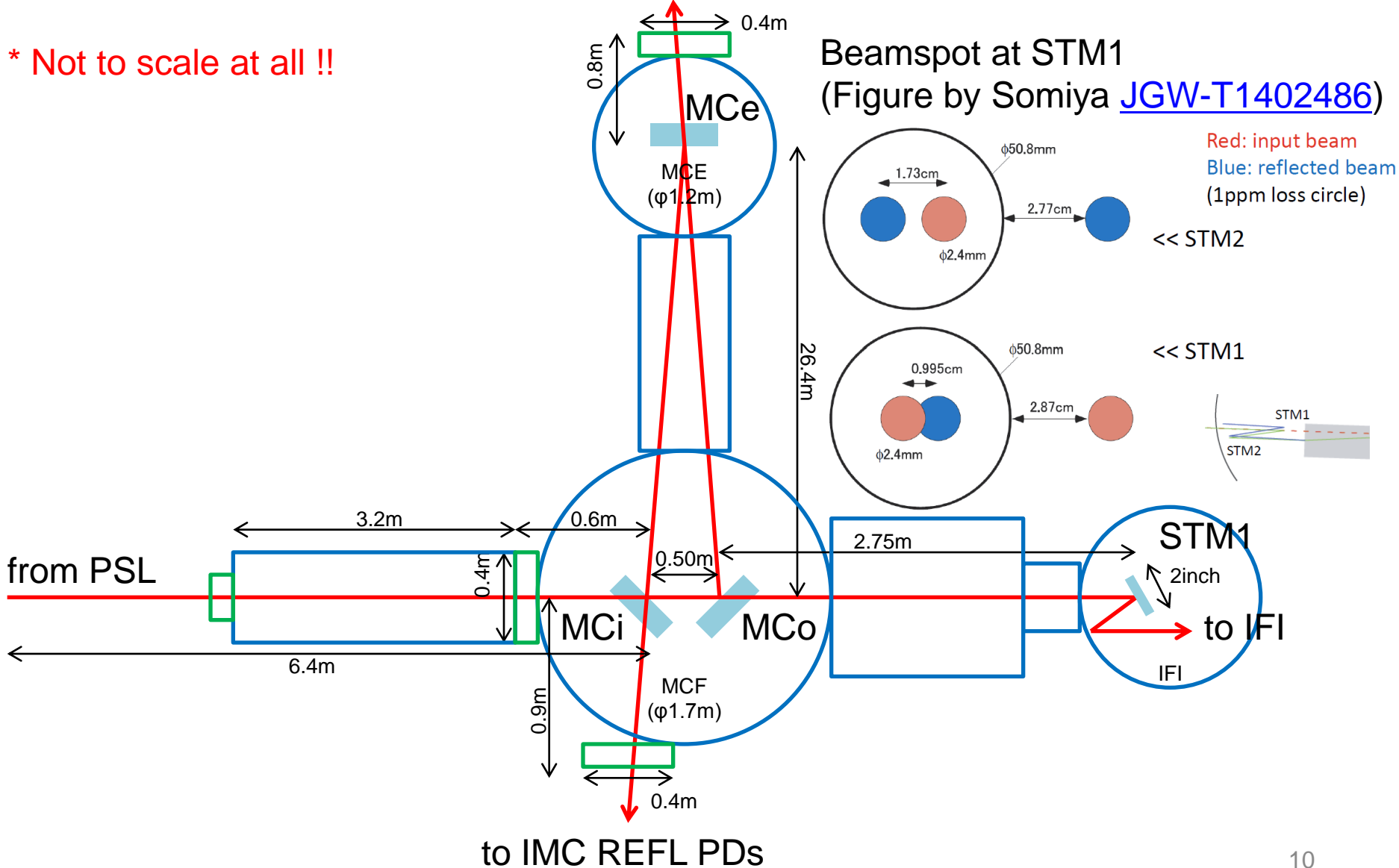

Beam Displacements

- Assumption: All the mirrors are aligned so that the beam hits the mirror at the center, even if they are misplaced
- all values are in m/m

	Laser Inj.	IMC REFL	IMC TRANS	STM1
γ_c	8.6	1.0	0	5.5
γ_a	7.6	0	0.03	6.5
γ_b	0	0.03	1.0	0

Summary 2

- If we set the requirement for the beam displacement at STM1 and viewports to be less than 1 cm;
- M_{Ci} placement error should be
disp < 1 mm
- M_{Co} placement error should be
disp < 1 mm
- M_{Ce} placement error should be
disp < 1 cm

- Oplev beams won't be blocked if mirrors are placed within the requirements above.

Requirement 3

- Alignments of IMC mirrors should be able to be fine adjusted with picomotors.
- So, placement error should be smaller than the picomotor actuation range.

IMC Angular Actuation Range

- Actuation range is limited by the gap (~1 mm) between the middle stage mass and damping magnets

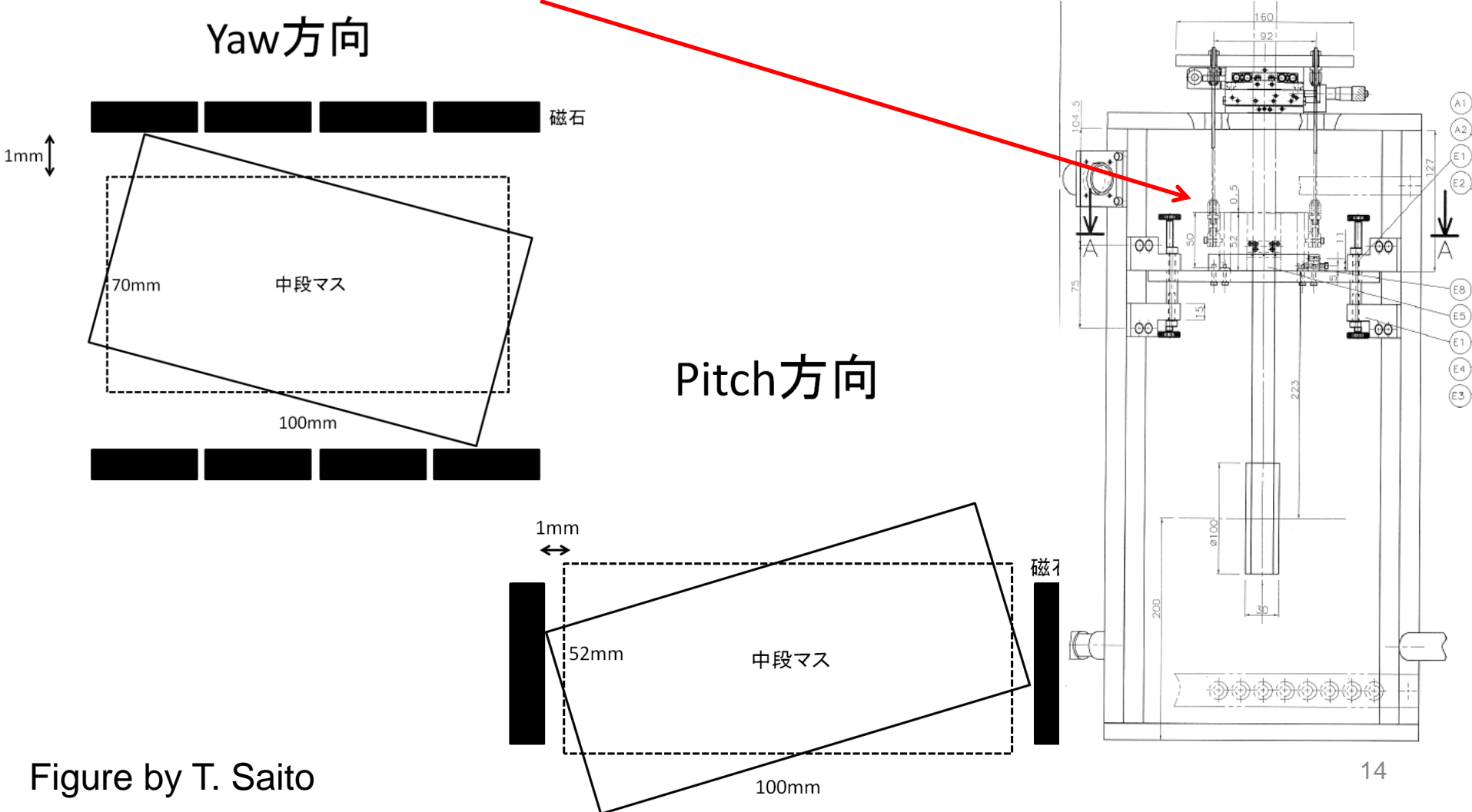

Figure by T. Saito

Summary 3

- Angular actuation range of IMC mirrors are ~1 deg in yaw, ~2 deg in pitch.