

# KAGRA ISC

# Electrical Components Layout

Yuta Michimura

Ando Group

Department of Physics, University of Tokyo

# Scope and Disclaimer

- Draw rough layout of electrical components (RF distribution, PD/QPDs, servo boards) for KAGRA ISC
- Cameras and picomotors are not included
- Components for ISS, ALS, and OMC are very uncertain
- “AS rack” is currently not on the rack list
- JGW-D1402908 ones are used also for iKAGRA
- References:
  - JGW-D1402908 (IMC servo topology)
  - JGW-D1402984 (Cabling around PSL+IMC)
  - JGW-D1100425 (electronics racks layout)
  - JGW-D1402831 (what’s inside electronics racks)
  - JGW-T1402982 (list of ISC detection ports)
  - Wiki/OutputTables (list of output tables)

# KAGRA Layout

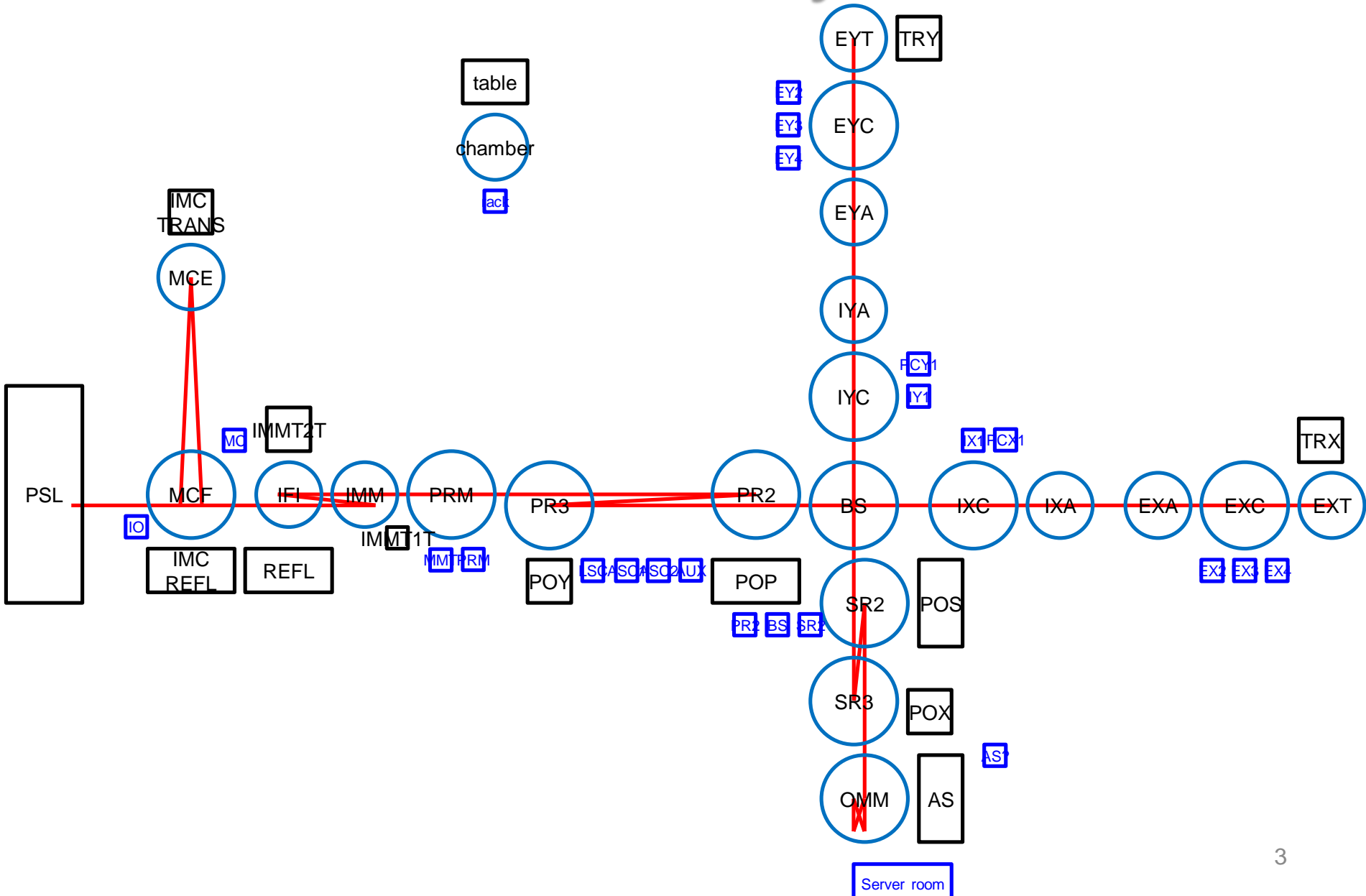

# List of EOMs, PDs, QPDs

Underline: also for iKAGRA  
[ ]: may be omitted

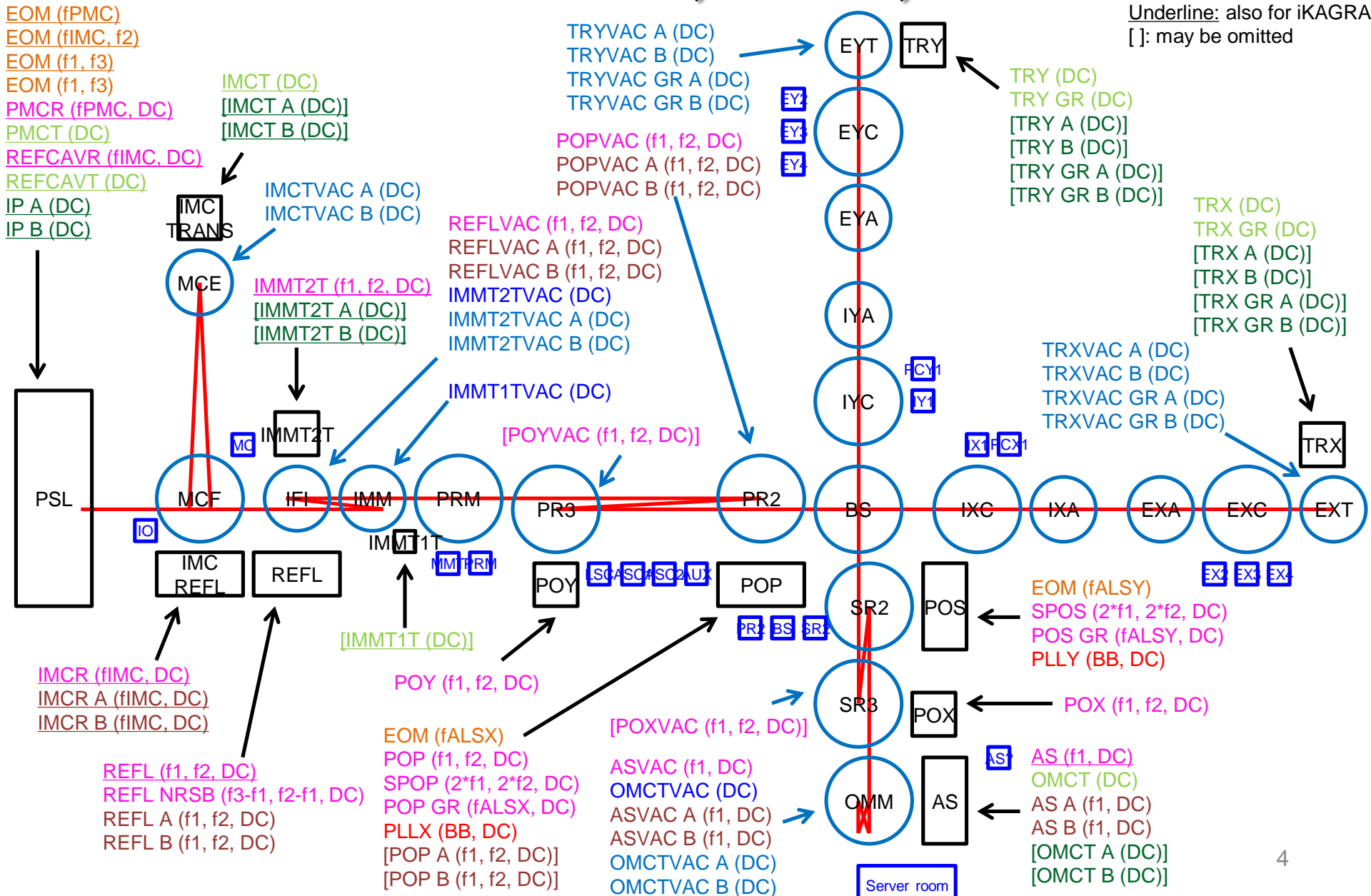

# Where Do Signals Go

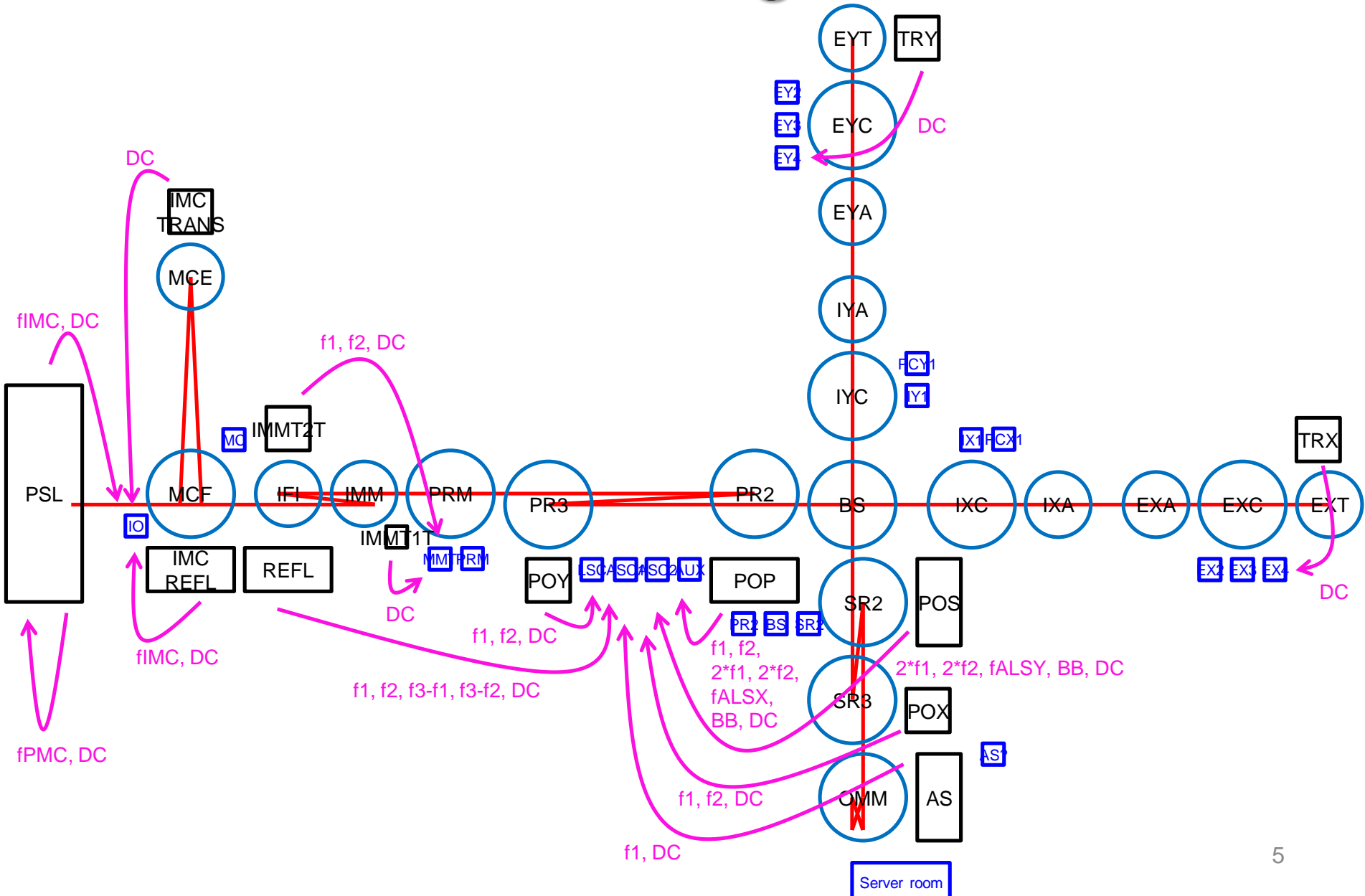

# RF Generation and Distribution

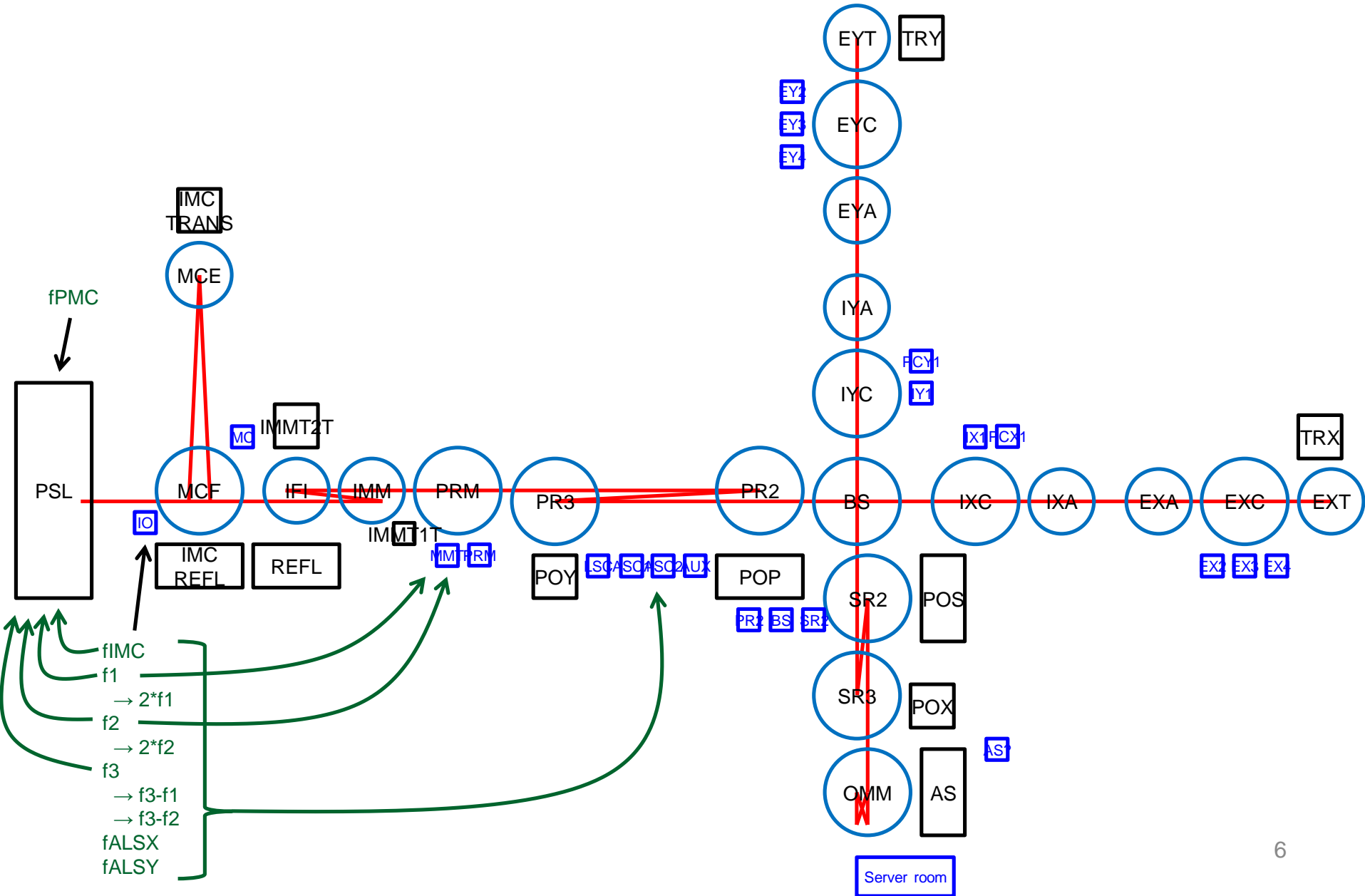

# List of Servo Boards

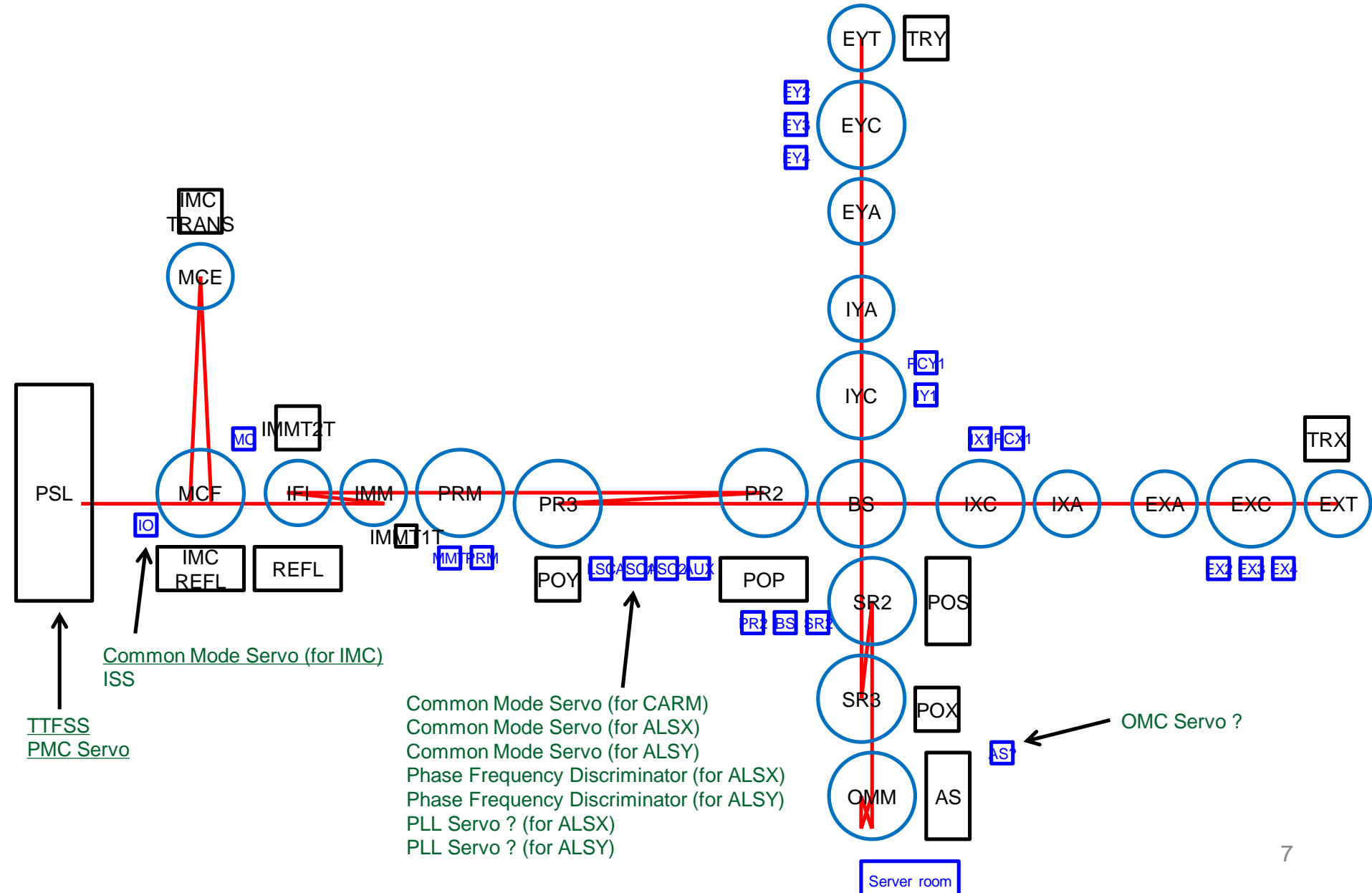

# List of PZTs

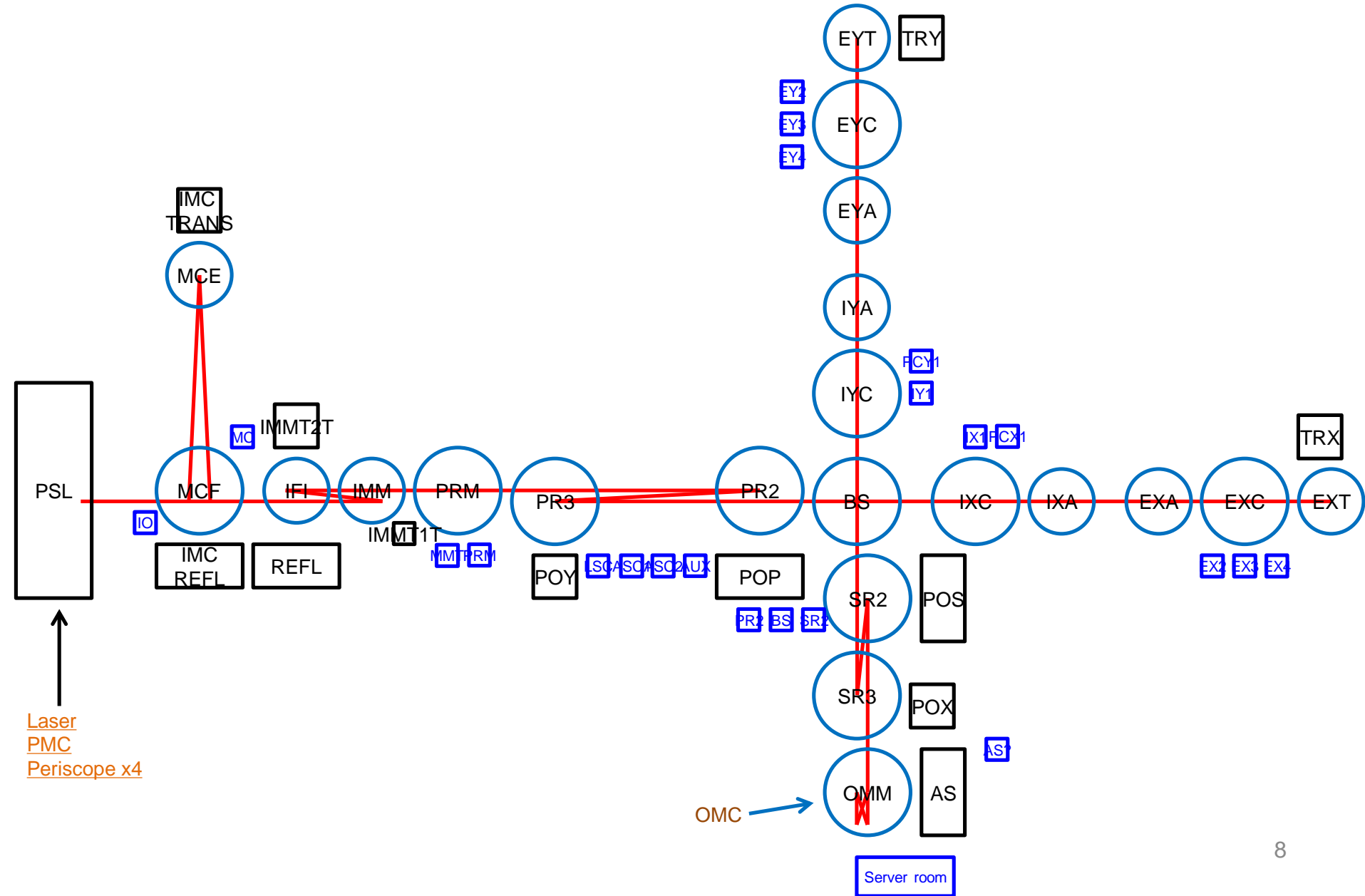



# List of Picomotors

