

KAGRA ISC

Electrical Components Layout

Yuta Michimura

Ando Group

Department of Physics, University of Tokyo

Scope and Disclaimer

- Draw rough layout of electrical components (RF distribution, PD/QPDs, servo boards) for KAGRA ISC
- Cameras and picomotors are not included
- Components for ISS, ALS, and OMC are very uncertain
- “AS rack” is currently not on the rack list
- References:
 - [JGW-D1402908](#) (IMC servo topology)
 - [JGW-D1402984](#) (Cabling around PSL+IMC)
 - [JGW-D1100425](#) (electronics racks layout)
 - [JGW-D1402831](#) (what’s inside electronics racks)
 - [JGW-T1402982](#) (list of ISC detection ports)
 - [Wiki/OutputTables](#) (list of output tables)

KAGRA Layout

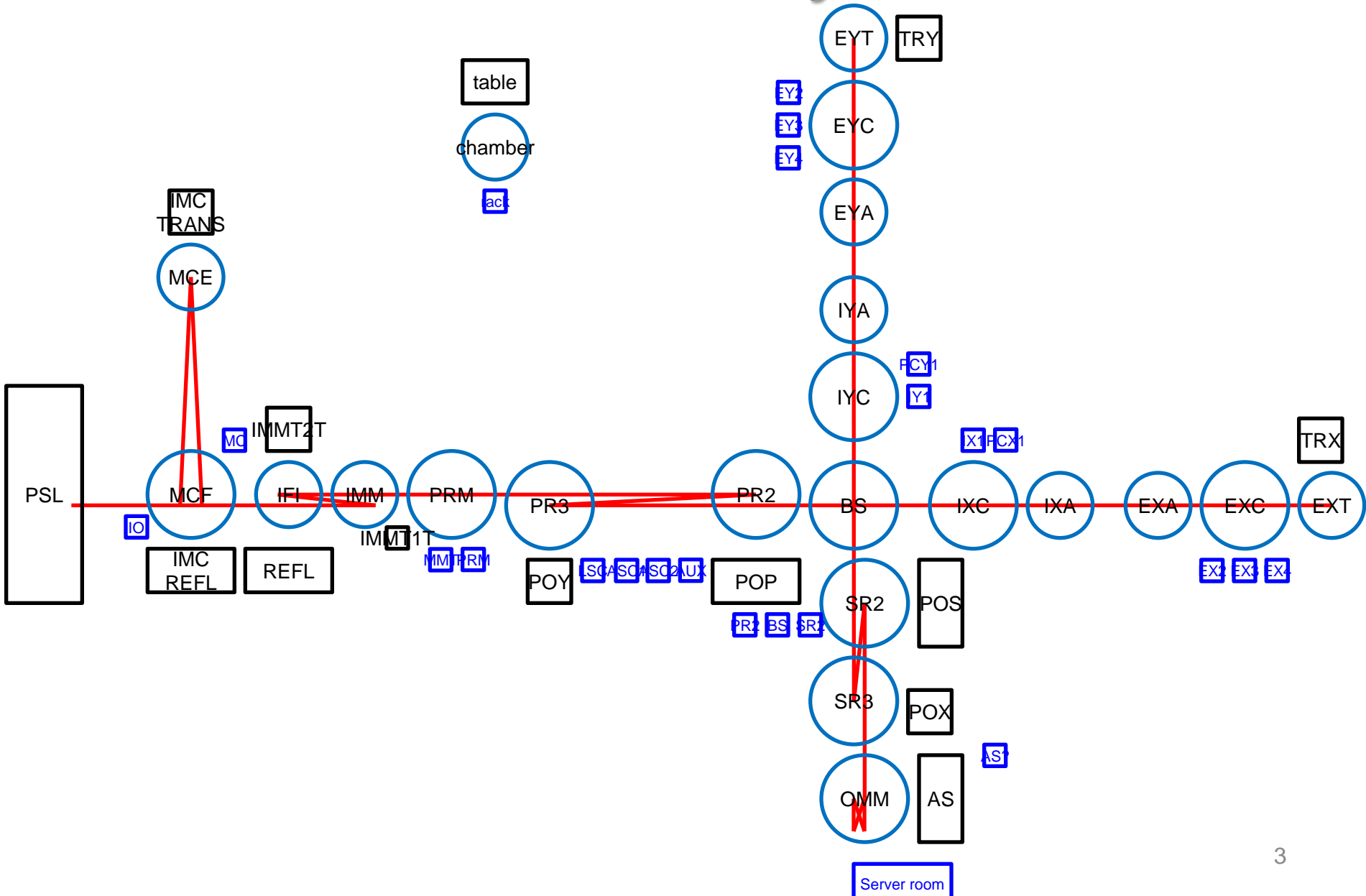

List of EOMs, PDs, QPDs

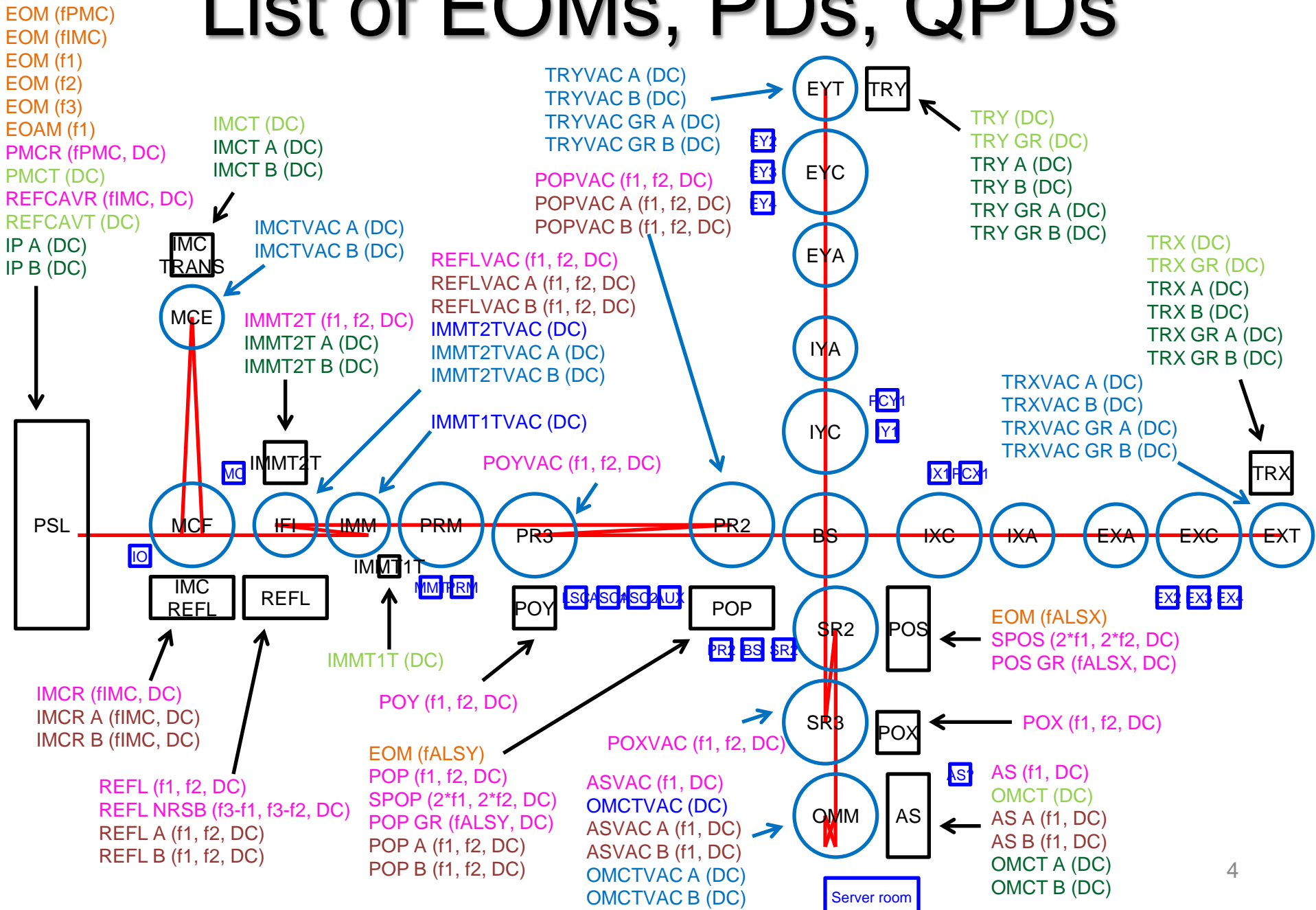

Where Do Signals Go

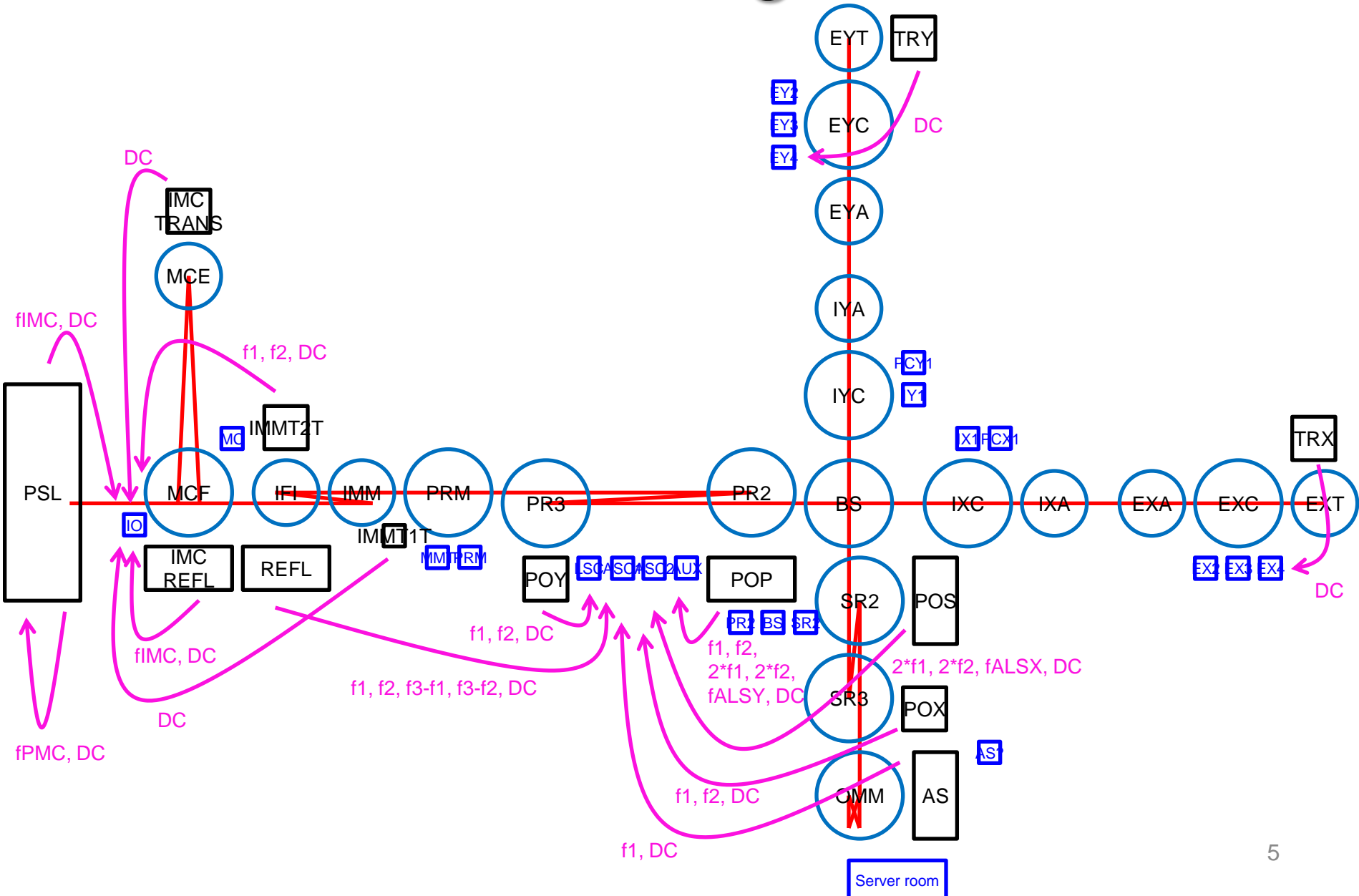

RF Generation and Distribution

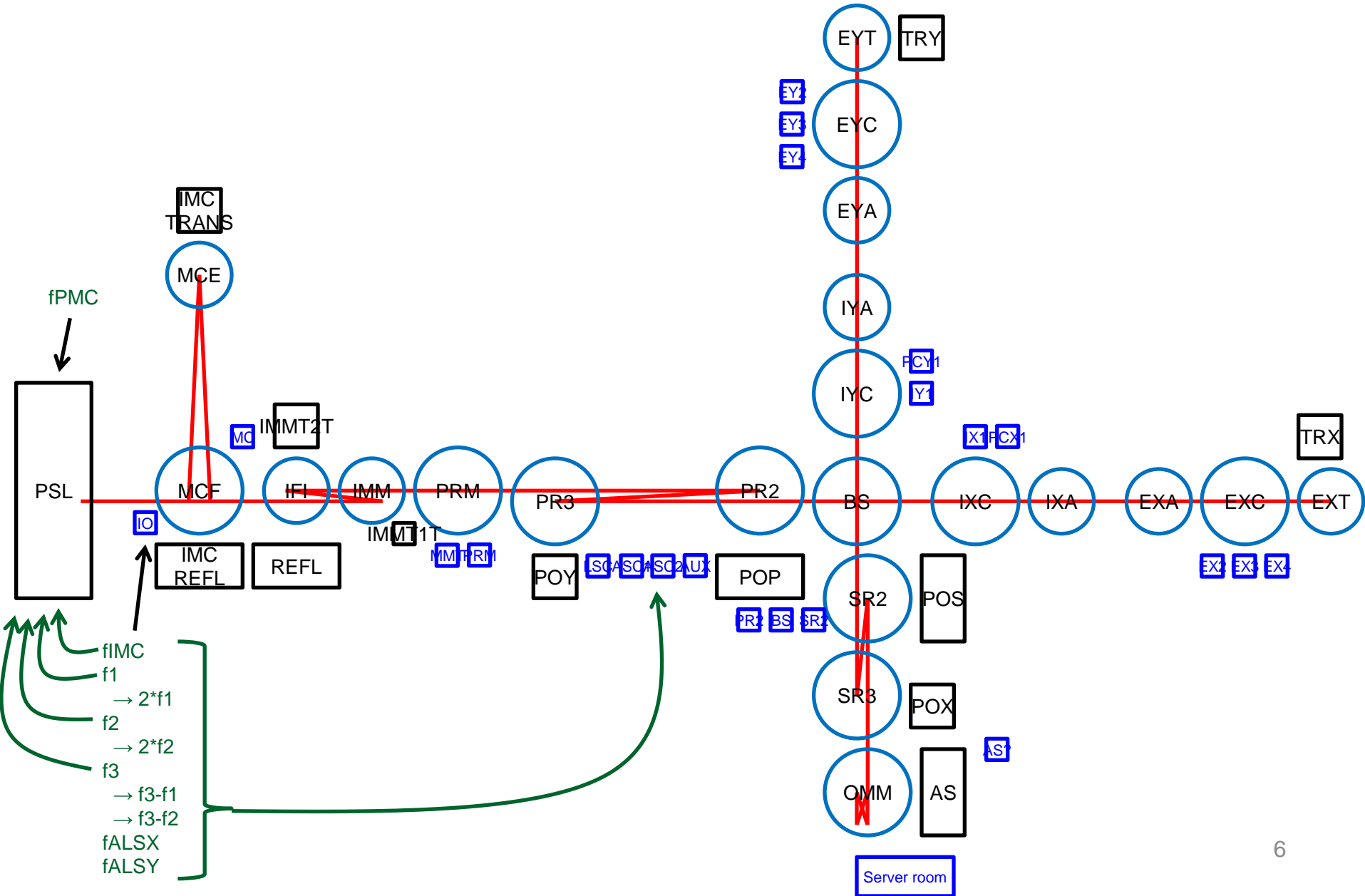

Servo Boards

