

# **Status of KAGRA Detector Characterization**

**Kazuhiro Hayama  
on behalf of the detector characterization group**

# Scope of the detector characterization

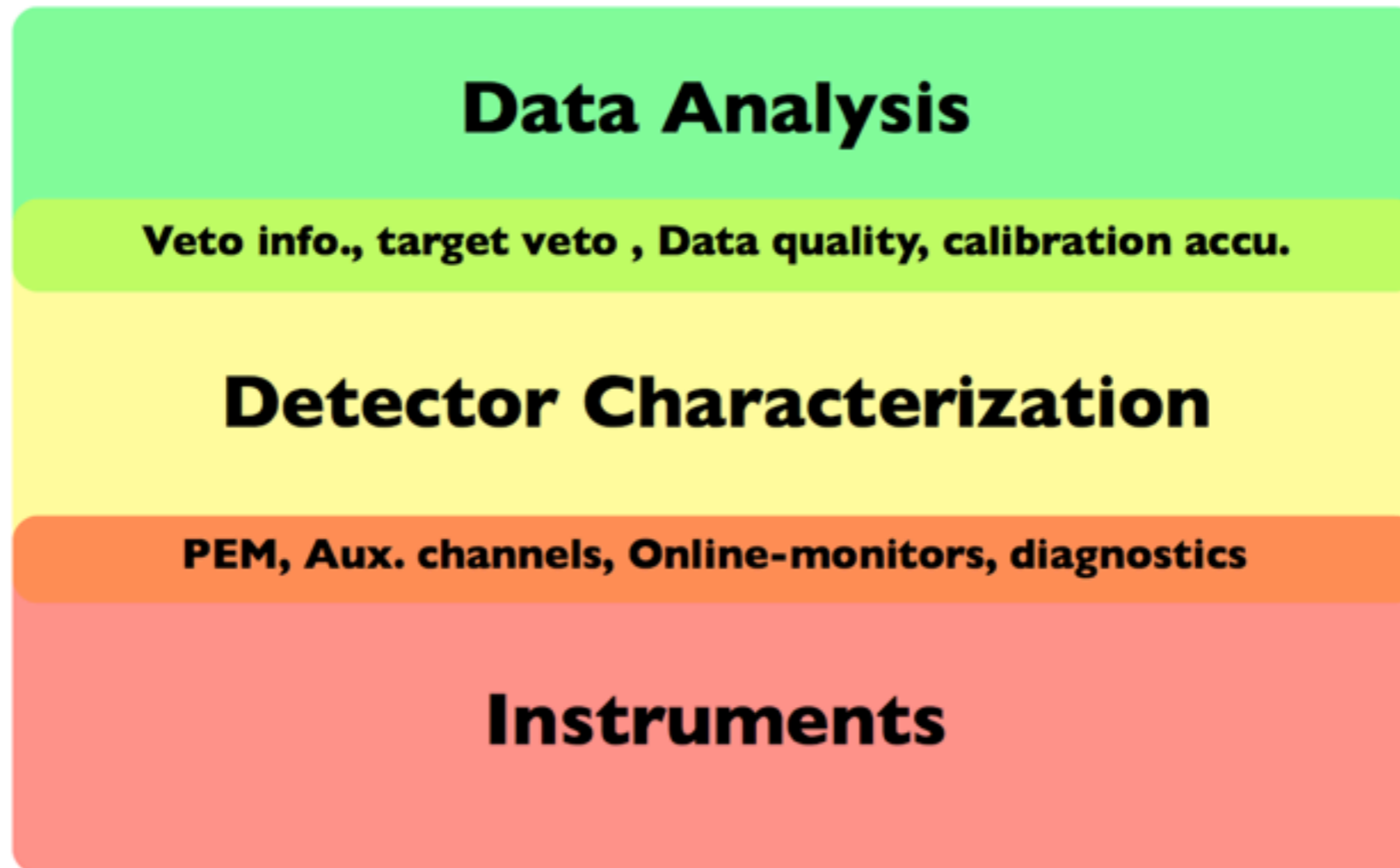

**Two Direction : To provide system, tools for**

- **Detector diagnostics, speed-up commissioning**
- **Monitor data quality, Veto analysis**

# Subsystem detector characterization



## Speed-up commissioning

- **Subsystem Diagnostics**
  - **ADC noise is within range?**
  - **Whitening requirement?**
  - **Channel correlated noise?**
  - **Find good frequency region for calibration**
  - **Components consisting the subsystem is working correctly?**
  - **Noise budget**
- **Kill source of glitches, lines**

# Multiple-subsystem characterization

## Speed-up commissioning

### Example of correlated noise between subsystems

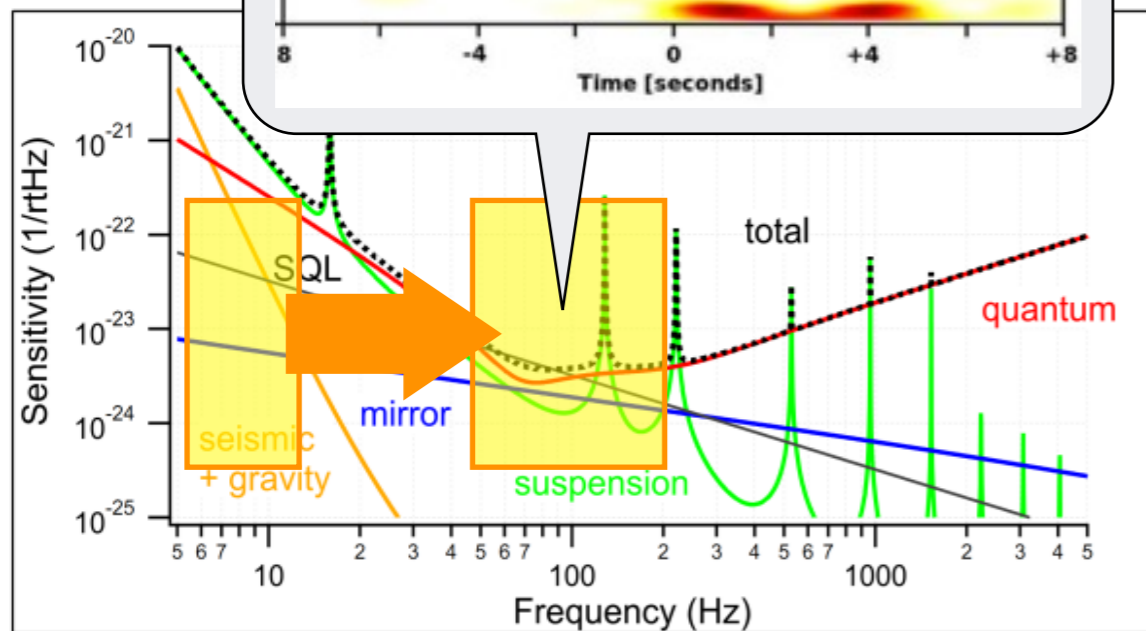
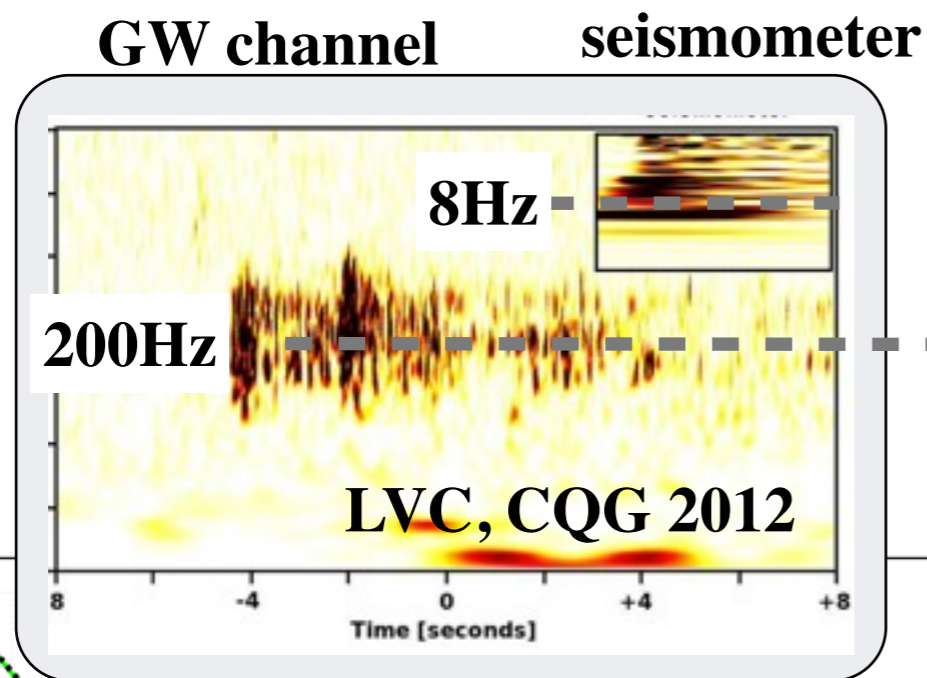

Sensitivity curve of KAGRA

- Need to watch channels over subsystems
- Up-conversion noise: seismic glitches will excite optical bench motion which cause scattered light noise.  
-> AOS-VIS channels
- Correlation analysis between multiple subsystems, Multi variate analysis using lots of channels will be important to find/understand/kill such noise source.



# Data quality monitor, Veto Analysis

## Categorization of data quality

Category	Definition	Prescription for analyses
CAT1	Flags obvious and severe malfunctions of the detector.	Science data are re-defined when removing CAT1 segments.
CAT2	Flags noisy periods where the coupling between the noise source and the DF is well-established.	Triggers can be automatically removed if flagged by a CAT2 veto. Good performance.
CAT3	Flags noisy periods where the coupling between the noise source and the DF is not well-established.	CAT3 flags should not be applied automatically. Triggers flagged by a CAT3 veto should be followed up carefully.

LVC

## Post processing : Veto Analysis

Veto list generation		
Transient GW (CBC, Burst)	Continuous GW (pulsar, LMXB, ...)	Stochastic GW (Early Univ, ...)
<ul style="list-style-type: none"> <li>• Real-time glitch detection</li> <li>• Glitch classification</li> <li>• Coincidence analysis between the GW channel and auxiliary sensor channels.</li> <li>• ...</li> </ul>	<ul style="list-style-type: none"> <li>• Line tracking</li> <li>• Line detection</li> <li>• Removal of high frequency spikes</li> <li>• ...</li> </ul>	<ul style="list-style-type: none"> <li>• Noise floor monitor</li> <li>• Non-stationary</li> <li>• ...</li> </ul>

# Detector Characterization Cluster

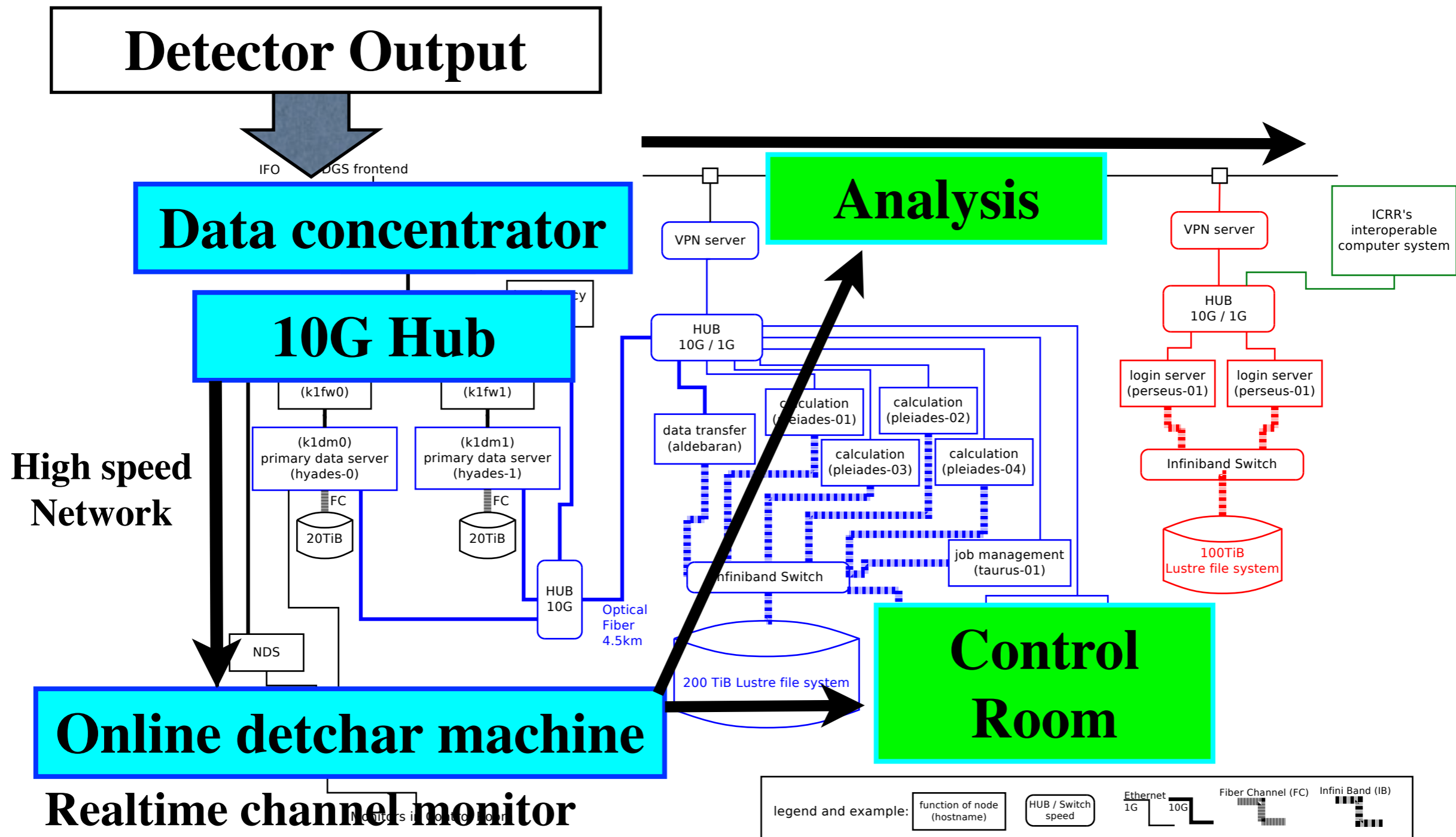

**Kanda**

# On going DetChar projects

## Primary Projects

- To maintain Diagnostics Test Tool
- Detchar GUI
- Glitch Monitor
- Line Monitor
- Noise Modeling
- Rayleigh Monitor
- Noise Floor Monitoring
- Range Monitor  
(Inspiral,  
Ringdown,  
Insp-Merger-Ringdown)
- Noise Budget
- Health Monitor
- Data base
- Quality flag
- Detchar summary page

## Special Projects

- Globally correlated noise
- Violin mode
- Multi-Channel Analysis  
(with Korea detchar, Mano)
- Detchar shift plan
- Newtonian Noise

in progress

in slowly progress



# HasKAL : DetChar tools/system



- Haskell-based analysis software package
  - **Runtime Error FREE** by strong type checking system
  - **Easily integrate** KAGALI, LAL, FrameLib,..
  - **Short debugging time by short coding**

Actively being developed at GitHub (Open to everyone)

Tools for gravitational w

The screenshot shows the GitHub repository page for 'detector-characterization'. At the top, it displays repository statistics: 246 commits, 3 branches, 0 releases, and 7 contributors. Below this is a progress bar with green, purple, and yellow segments. The main content area shows a commit history table with columns for commit message, author, and time. The most recent commit is by 'enoshima' 22 hours ago, updating 'firFiler, iirFilter'. Other commits include adding 'gsl functions', changing directory structure, and adding cache file designations. A file named '.gitignore' is listed as the initial commit. A URL is overlaid on the bottom of the screenshot: <https://github.com/gw-analysis/detector-characterization>

Commit Message	Author	Time
firFiler, iirFilter updated	enoshima	22 hours ago
add some gsl functions		6 days ago
change directory structure of option files		6 days ago
add entry form of designating cache file		22 days ago
Initial commit		
window function is selectable in gwpsdCore		a day ago



# Structure of HasKAL



branch: **master** **detector-characterization** / **HasKAL** / **src** / **HasKAL** / +

firFiler, iirFilter updated

**enoshima** authored 22 hours ago

..

<b>DetectorUtils</b>	Detector.hsfixed
<b>ExternalUtils</b>	change time-variable from String to Tuple
<b>FrameUtils</b>	modified PickUpFileName.hs
<b>GUI_Utils</b>	change time-variable from String to Tuple
<b>MonitorUtils</b>	change time-variable from String to Tuple
<b>PlotUtils</b>	remove argument of tapplication from module
<b>SignalProcessingUtils</b>	firFiler, iirFilter updated
<b>SpectrumUtils</b>	window function is selectable in gwpsdCore
<b>TimeUtils</b>	generate timetuple2gps by Yokozawa

# DetChar GUI

## Running Glitch Monitor (kleineWelle)

The screenshot displays the DetChar GUI interface. The 'KleineWelle' window is active, showing a list of parameters for monitoring. The 'Cache file' is set to 'gwffiles\_sort...'. The date and time are set to 2014, 3, 17, 16:15:12 JST. The plot titled 'TITLE 3' shows a scatter plot of data points with a grid. The x-axis ranges from 1079075742.5 to 1079075757.5, and the y-axis ranges from 0 to 700. The plot contains several data points in various colors (blue, green, orange, red, yellow, grey). A blue circle with the text 'HOGHEHOGE' is overlaid on the plot.

Cache file: gwffiles\_sort...

Year: 2014

Month: 3

Day: 17

Hour: 16

Minute: 15

Second: 12

timeZone: JST

Parameters:

- ifo
- peak\_time
- peak\_time\_ns
- start\_time
- start\_time\_ns
- duration
- search
- central\_freq
- channel
- amplitude

Buttons: Glitch, Line, Gaussianity, RangeMon, Exit

Buttons: KleineWelle, Close

```
Write data. Start: 1079075824:000000000 end: 1079075840:
1:X15-ADC_FILTER_00_IN1_DQ-1079075824-16.xml
Write data. Start: 1079075840:000000000 end: 1079075840:
Q-1079075824-16.xml
# finished processing stride - Thu Jun 19 16:51:57 2014
# processing at 1079075840:000000000 offset 1.07908e+09
Write data. Start: 1079075840:000000000 end: 1079075856:
1:X15-ADC_FILTER_00_IN1_DQ-1079075840-16.xml
Write data. Start: 1079075840:000000000 end: 1079075856:
Q-1079075840-16.xml
# finished processing stride - Thu Jun 19 16:51:57 2014
# processing at 1079075856:000000000 offset 1.07908e+09 16 0 - T
Write data. Start: 1079075856:000000000 end: 1079075872:000000000
1:X15-ADC_FILTER_00_IN1_DQ-1079075856-16.xml
Write data. Start: 1079075856:000000000 end: 1079075872:000000000
Q-1079075856-16.xml
# finished processing stride - Thu Jun 19 16:51:57 2014
No more requested files
synch: Unable to fetch next frame
Synch failed
# finished.
Data environment has terminated with Term/Attn/finish/EOF =0/0/0/
Run Plot tool
```

# ROOT based plotting

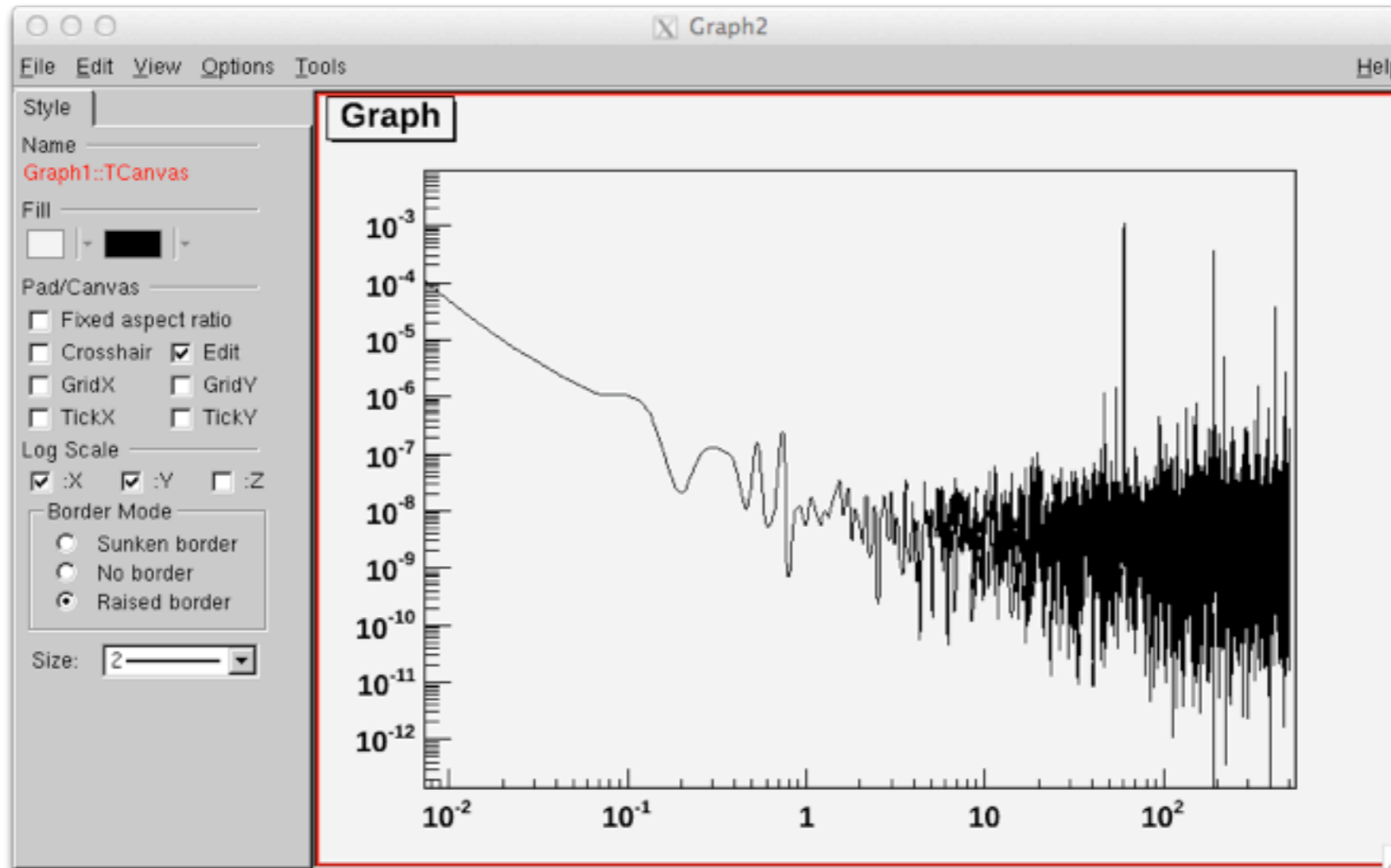

# Range Monitor

## Characterizing telescope sensitivities

### Inspiral

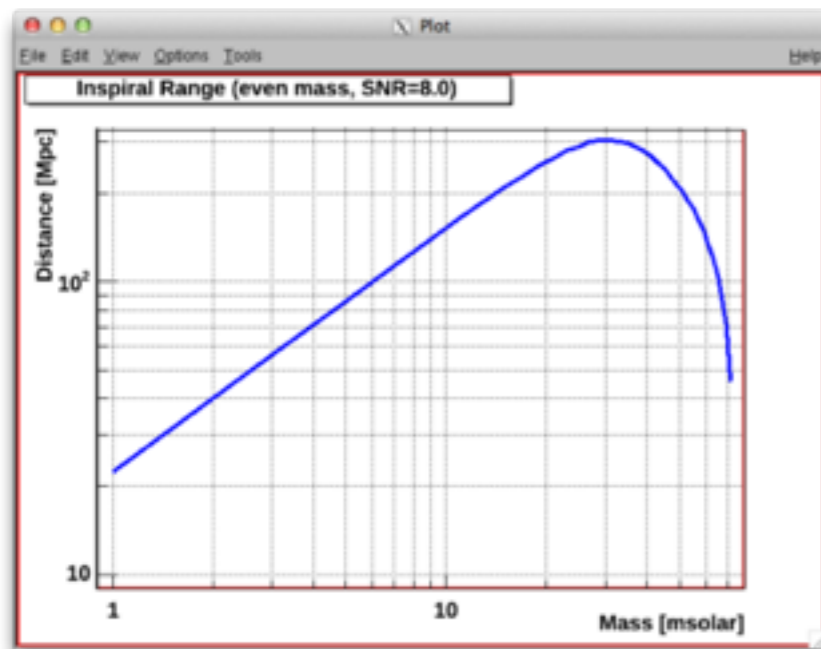

### Ringdown

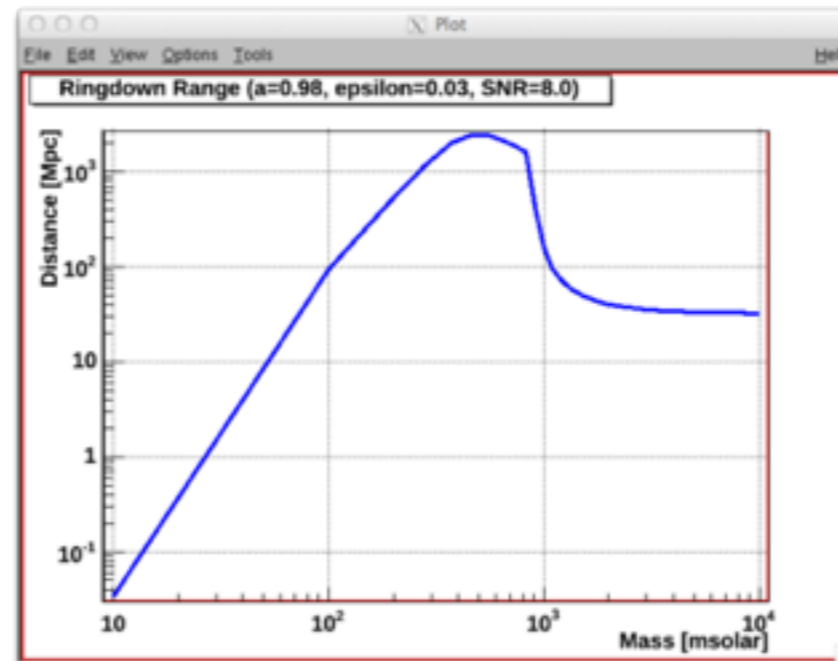

### IMBH (Inspiral+Merger+Ringdown)

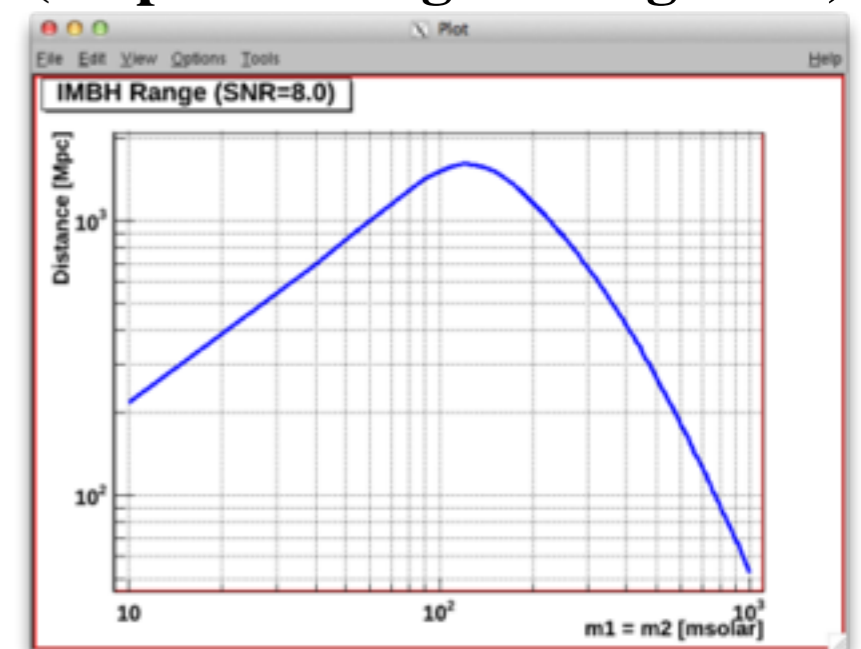



# Rayleigh Monitor



## Investigating noise behavior at various frequency regions

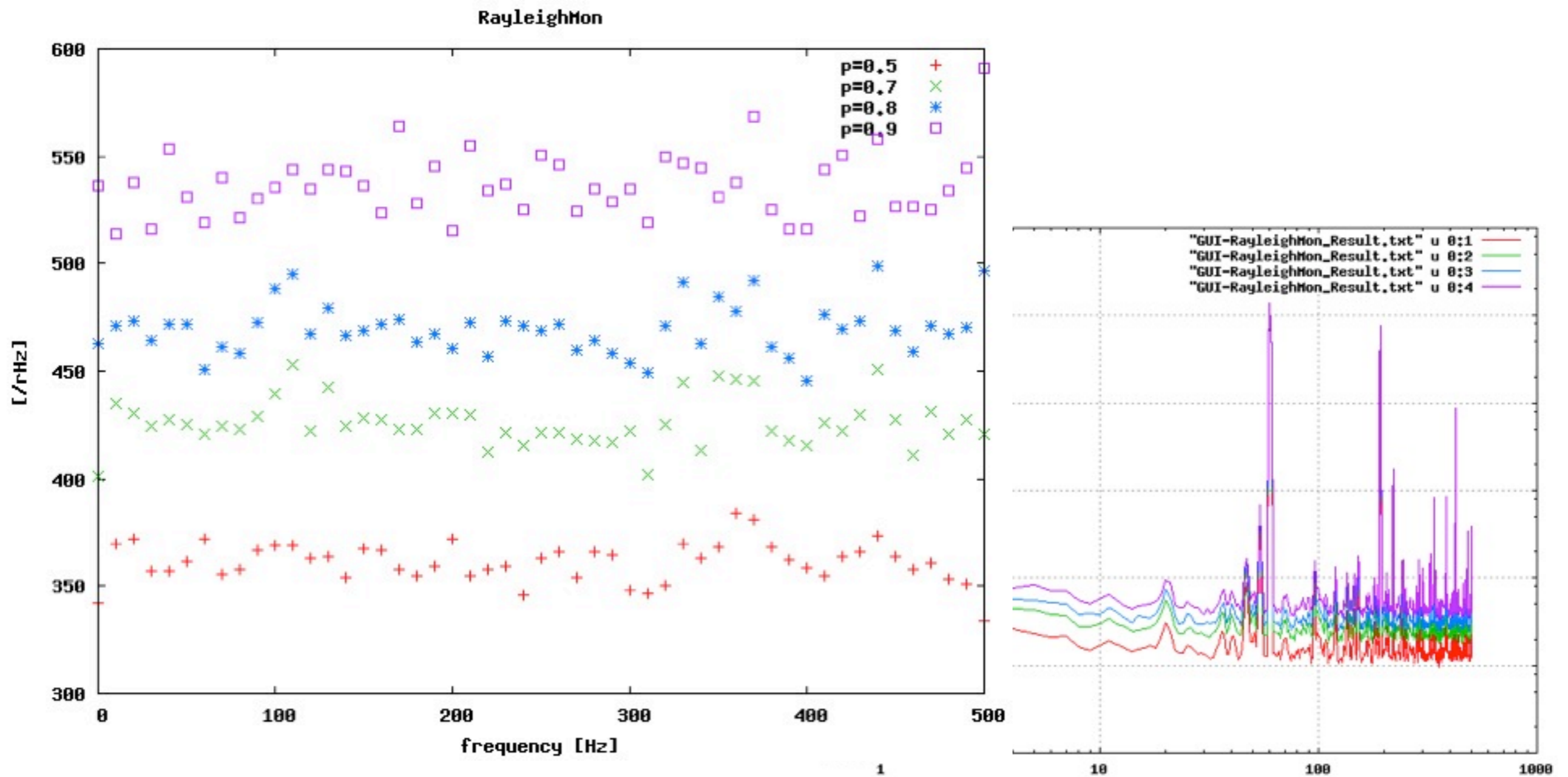



# New noise characterization tools



- **Realtime non-Gaussian noise modeling**
  - **In reality, even stationary noise is different from Gaussian noise.**
- **Non-linear correlation analysis between Aux channels**
- **Globally detector network monitor**

# Multi-Channel Analysis

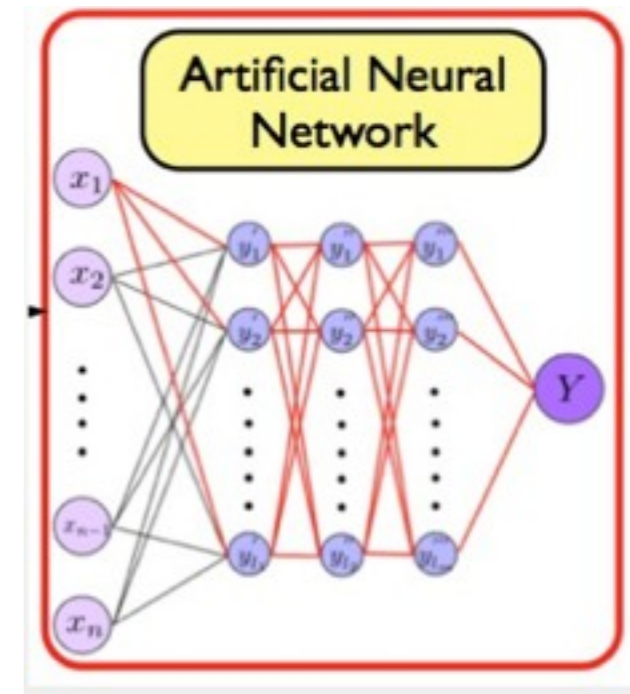

- Lead by Korean GW group
- Initial Goal:
  - Development of a method for localize noise sources using auxiliary channels and PEMs to support find/kill noise sources.
  - KGWG has been developing ANN based one for post-processing analysis in LVC.
  - We focuses on a tool useful for commissioning.
- Account to access KISTI cluster

# Integrating iDQ into HasKAL

- a low-latency pipeline which makes event-by-event predictions about the glitchiness of GW data based on auxiliary channel informations and provides data quality information.
- Finding responsible channels of glitches

Receiver Operating Characteristic Curve

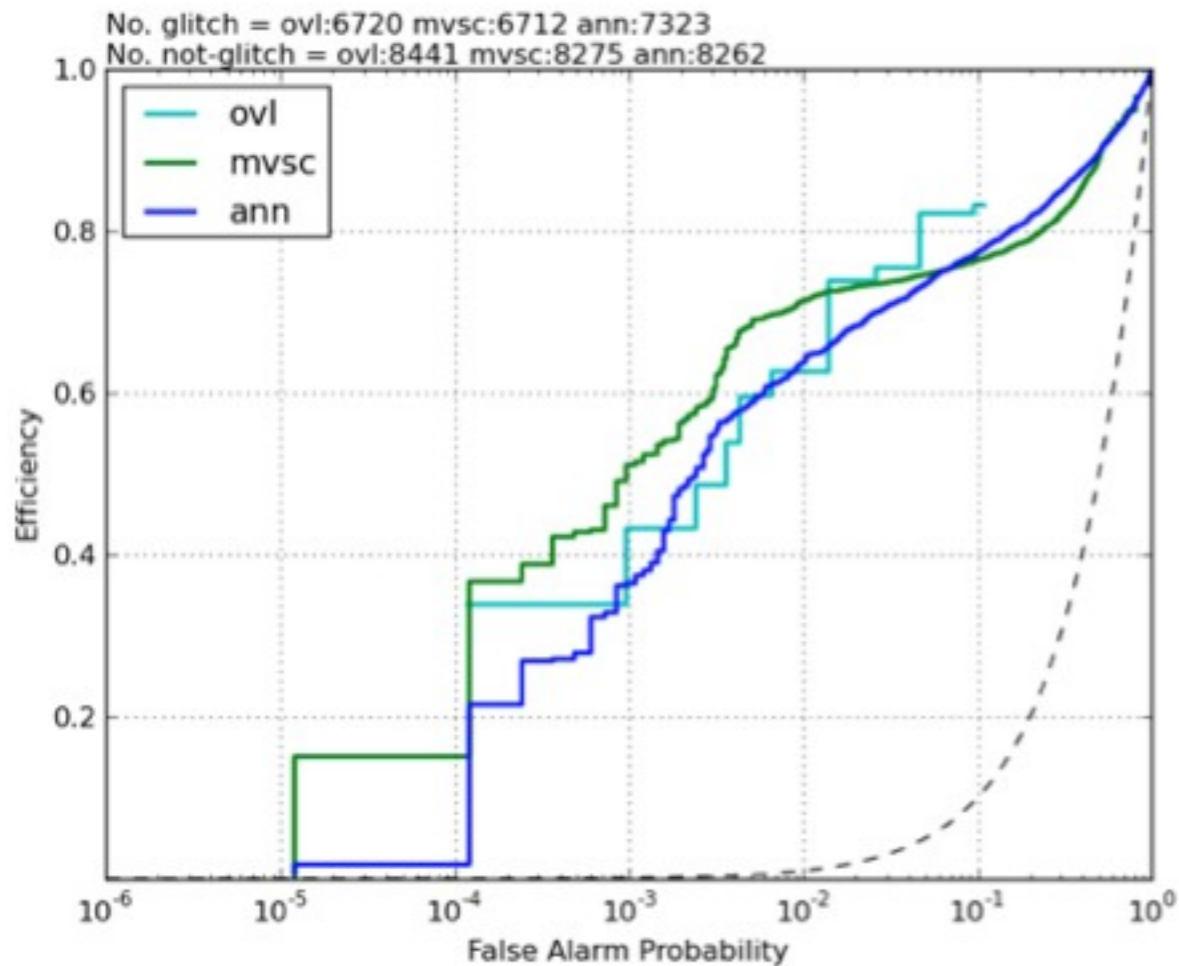

Channel performance trends

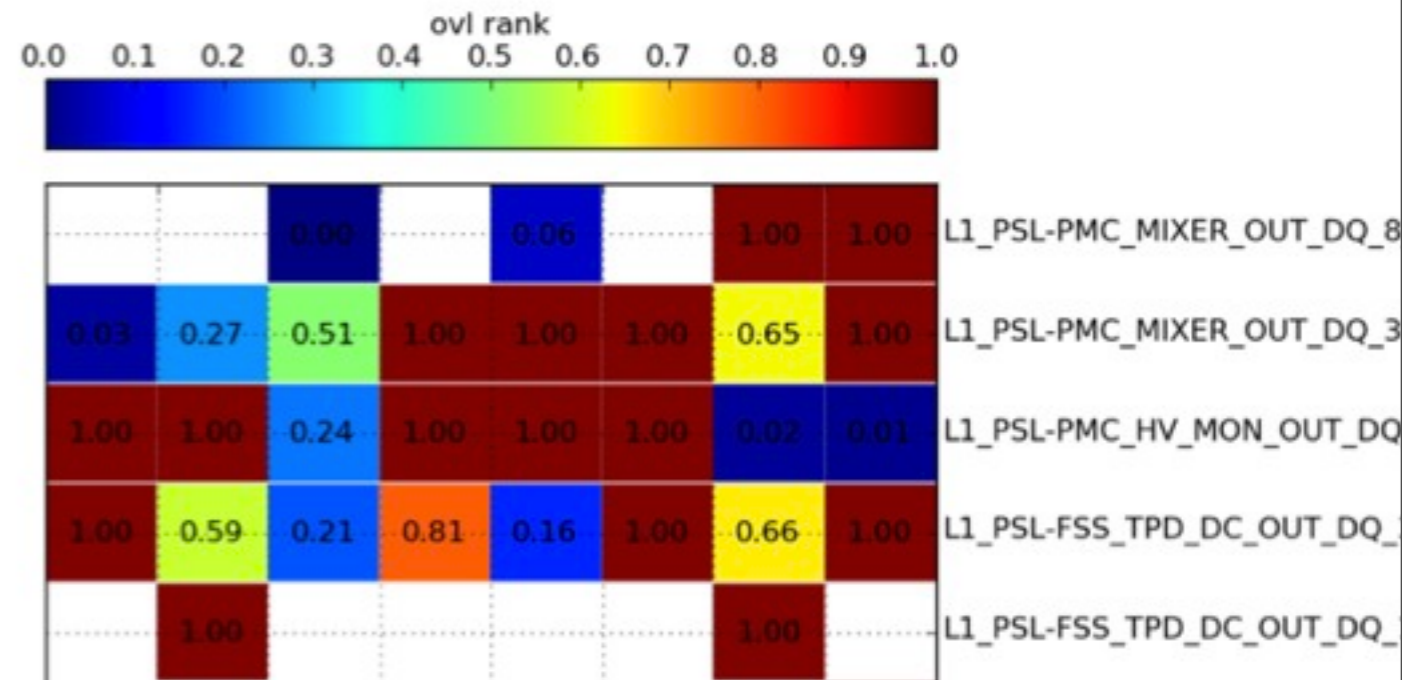

Young-Min Kim (Pusan Nat'l Univ.)

Japan-Korea KAGRA DetChar Call @ April 22, 2014

# Data quality study



Daisuke Tatsumi (NAOJ)

**Reduction of cryogenic induced glitches**

**KAGRA is a unique cryogenic detector in the world.**

**We are developing a method to quality the data condition.**

- **A noise monitoring system for the cryogenic system is developed at TAMA 300.**
- **Our goal is to develop a system to reduce the false alarm rate to 1/month.**





# Noise Characterization at the KAGRA site

**Seismic noise : < 2Hz  
consistent with CLIO  
high frequency under investigation**

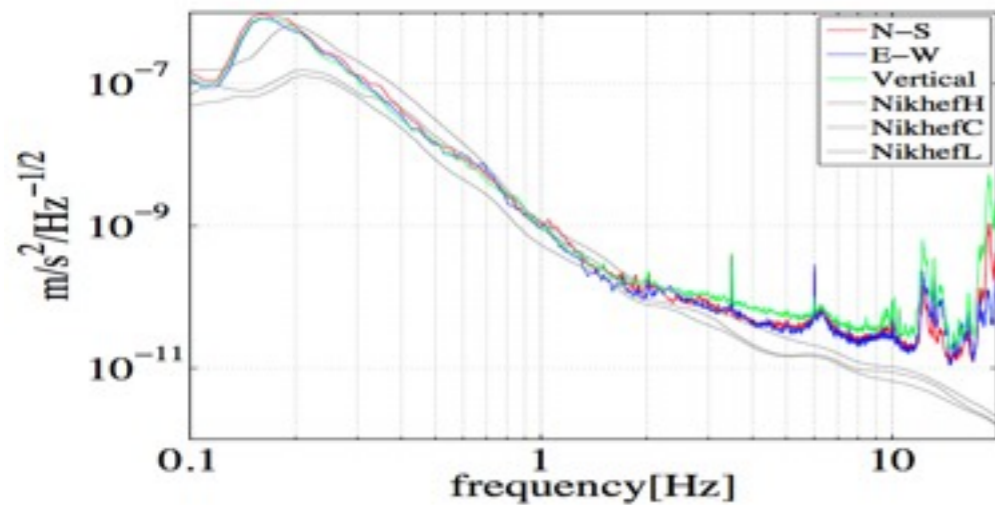

**Stationarity: not bad, but  
longer data needed**

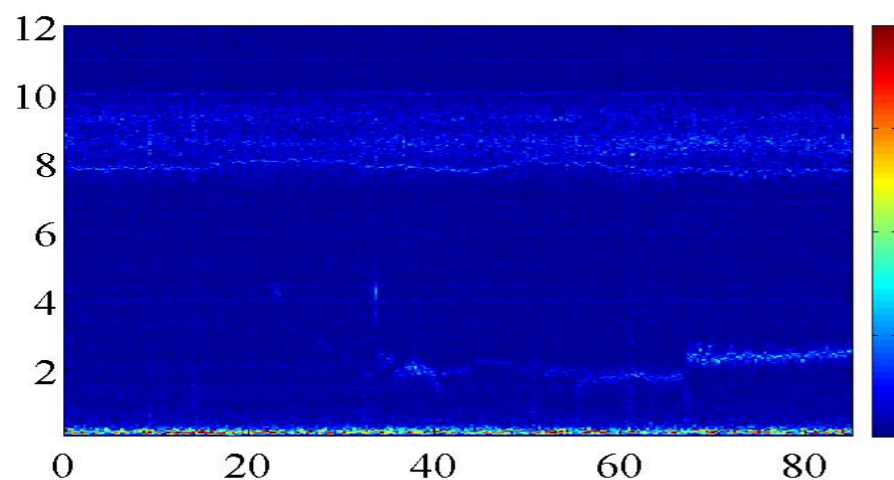

**magnetic field : Requirement of  
Coil-magnet actuator**

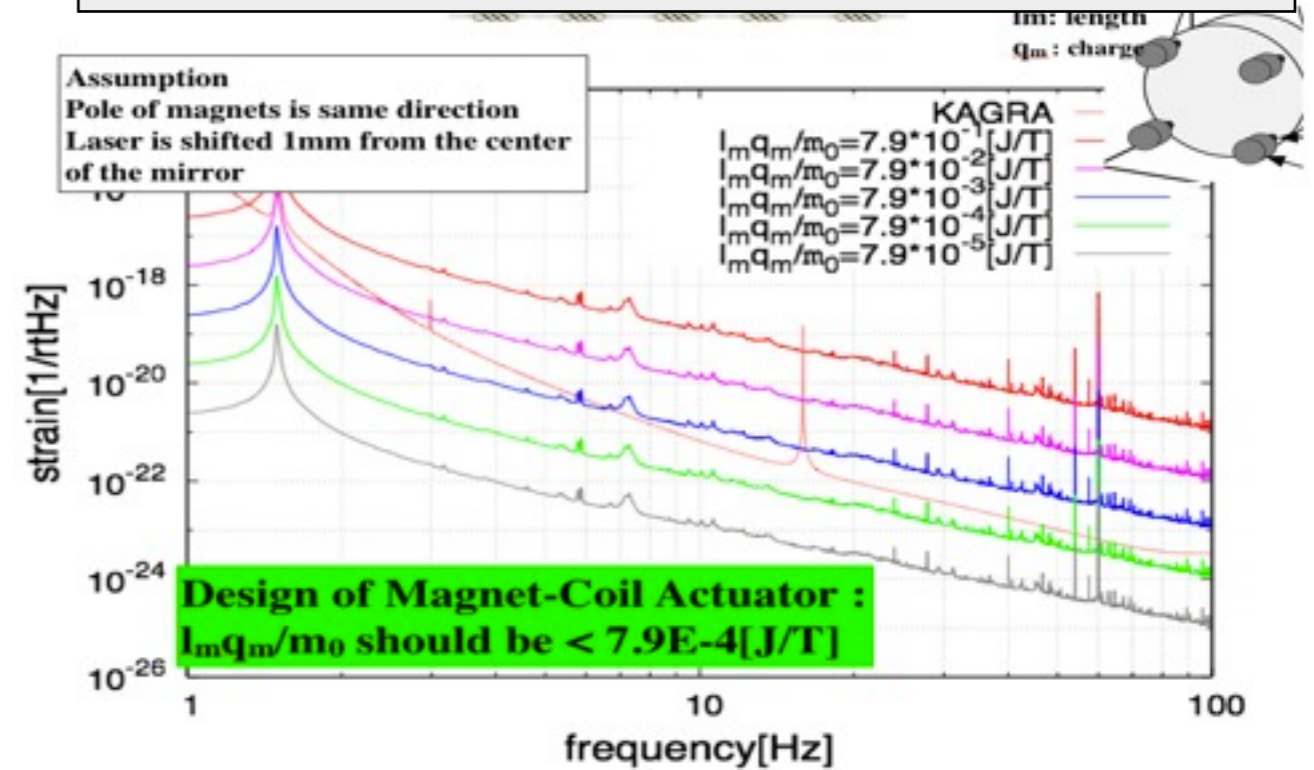

**No strange magnetic sources**

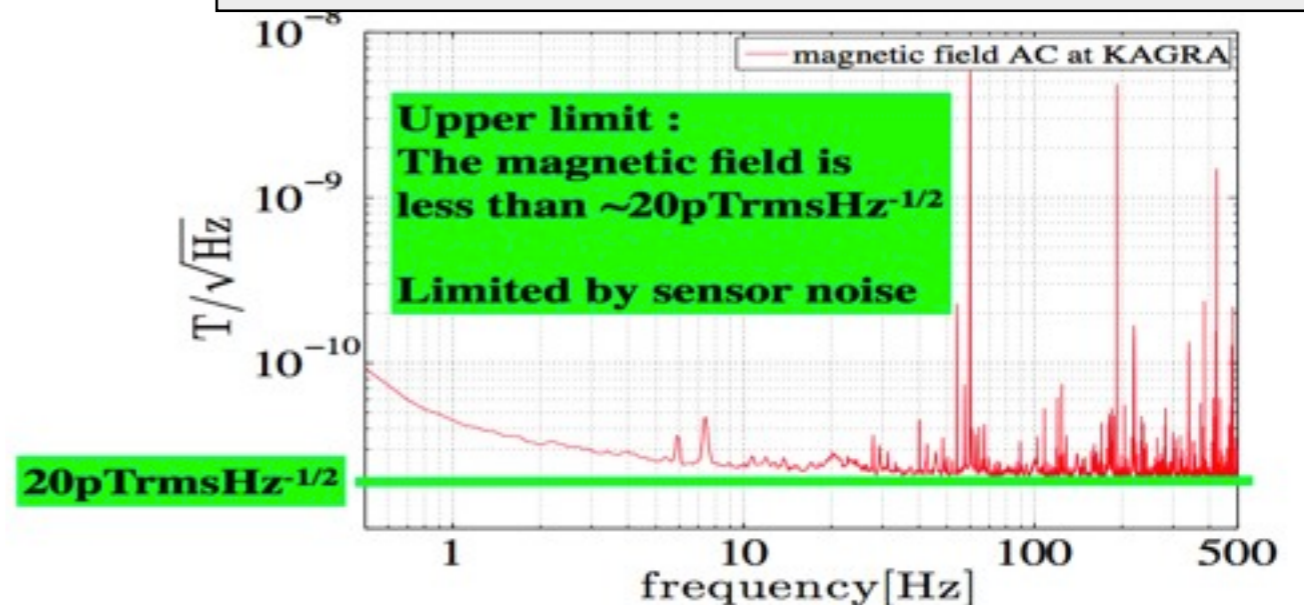



# S : Globally Correlated Magnetic Noise

## Global correlated magnetic noise

Atsushi Nishizawa  
Kyoto Univ.

- Schumann resonance  
Resonance of the ionosphere due to discharge of thunders, solar wind,...
- very weak (0.5-1E-12T/rHz) (Earth's:1E-5T)

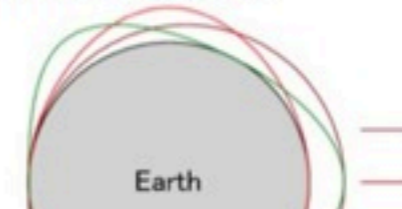

**Discussing possibility of Direct measurement of Schumann resonance at the KAGRA site collaboration with geophysicists at OCU.**

### Influence on SGWB search

detector pair	$h_0^2 \Omega_{gw}$ w/o magnetic noise	$h_0^2 \Omega_{gw}$ w/ magnetic noise	degradation factor
HL	$5.5 \times 10^{-9}$	$2.5 \times 10^{-8}$	4.55
HV	$2.4 \times 10^{-8}$	$4.1 \times 10^{-8}$	1.71
LV	$2.0 \times 10^{-8}$	$3.5 \times 10^{-8}$	1.75
KH	$3.8 \times 10^{-8}$	$5.0 \times 10^{-8}$	1.31
KL	$6.4 \times 10^{-8}$	$7.7 \times 10^{-8}$	1.20
KV	$2.2 \times 10^{-8}$	$3.4 \times 10^{-8}$	1.54

表 1: Detectable  $h_0^2 \Omega_{gw}$  with SNR = 5 for 1 yr observation time. Note that when correlation noise limits the sensitivity to  $\Omega_{gw}$ , longer observation time does not help improve the sensitivity.

# Schedule



- 2014 June : Installation of detchar GUI on VIS digital system at NAOJ so that VIS people use the GUI and feed back to us**
- 2014 Oct ~ : GIF will start operate some of environmental monitors. These monitor data will be retrieve by same digital system as KAGRA. We will do test-operation of the detchar system/tools using the monitor data.**
- 2014Oct-2015Dec Updating system and tools.**



# Environmental Monitors

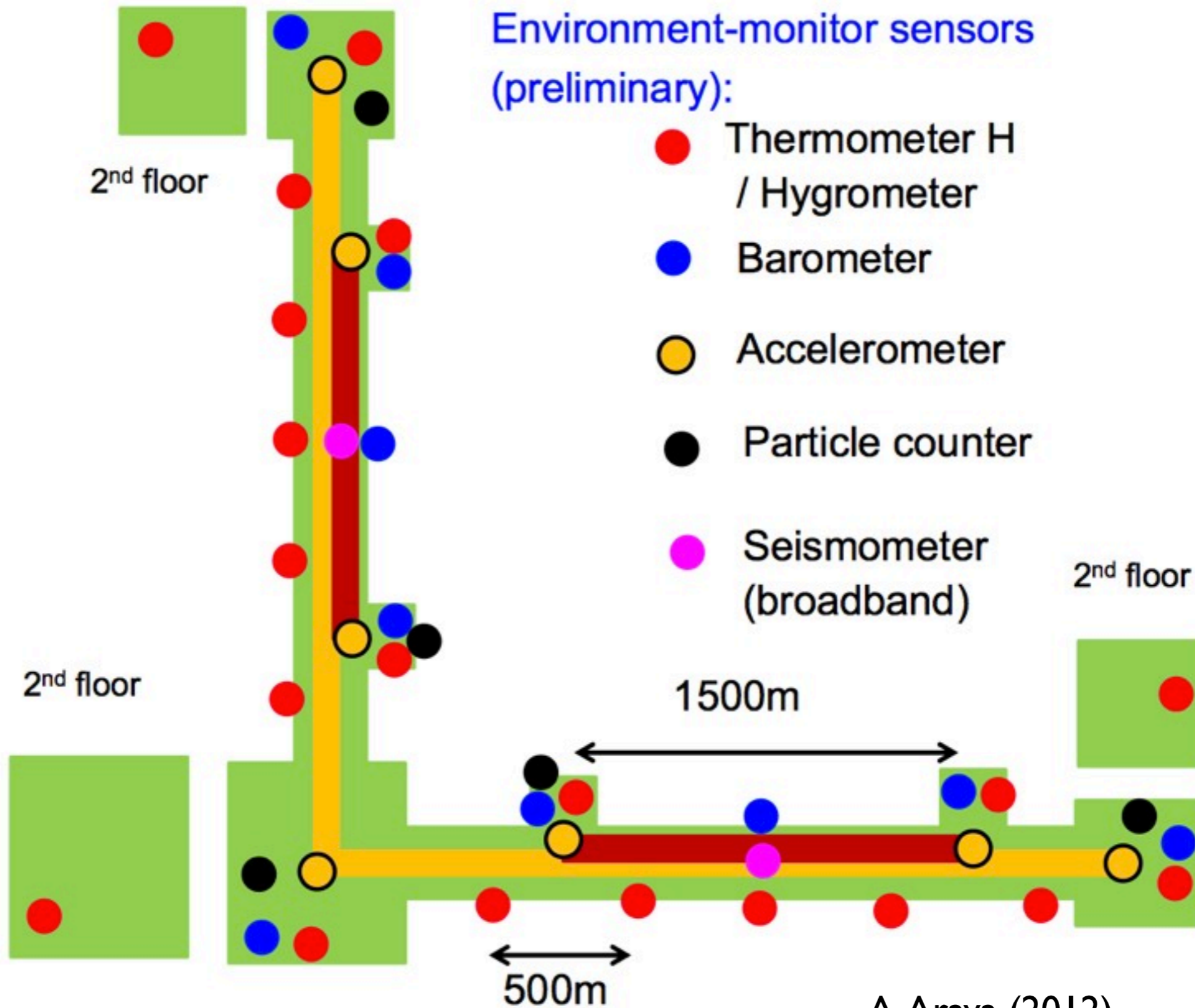

A.Araya (2012)



# S : Globally Correlated Magnetic Noise

Atsushi Nishizawa  
Kyoto Univ.

## Global correlated magnetic noise

- Schumann resonance  
Resonance of the ionosphere due to discharge of thunders, solar wind,...
- very weak (0.5-1E-12T/rHz) (Earth's:1E-5T)
- Long coherent length ~1000km
- Correlation shows up by 1 year integration

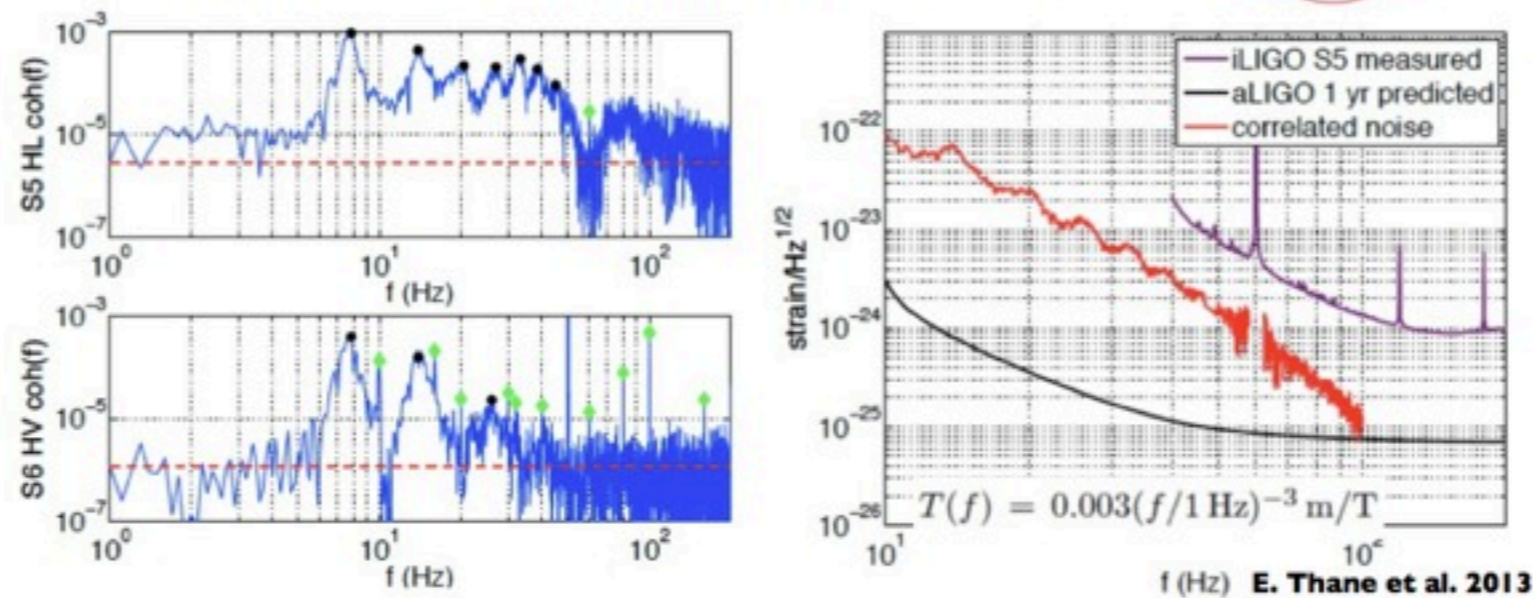
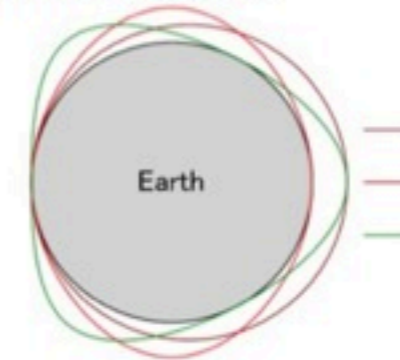

## Influence on SGWB search

detector pair	$h_0^2 \Omega_{\text{gw}}$ w/o magnetic noise	$h_0^2 \Omega_{\text{gw}}$ w/ magnetic noise	degradation factor
HL	$5.5 \times 10^{-9}$	$2.5 \times 10^{-8}$	4.55
HV	$2.4 \times 10^{-8}$	$4.1 \times 10^{-8}$	1.71
LV	$2.0 \times 10^{-8}$	$3.5 \times 10^{-8}$	1.75
KH	$3.8 \times 10^{-8}$	$5.0 \times 10^{-8}$	1.31
KL	$6.4 \times 10^{-8}$	$7.7 \times 10^{-8}$	1.20
KV	$2.2 \times 10^{-8}$	$3.4 \times 10^{-8}$	1.54

表 1: Detectable  $h_0^2 \Omega_{\text{gw}}$  with SNR = 5 for 1 yr observation time. Note that when correlation noise limits the sensitivity to  $\Omega_{\text{gw}}$ , longer observation time does not help improve the sensitivity.



# Structure of the projects

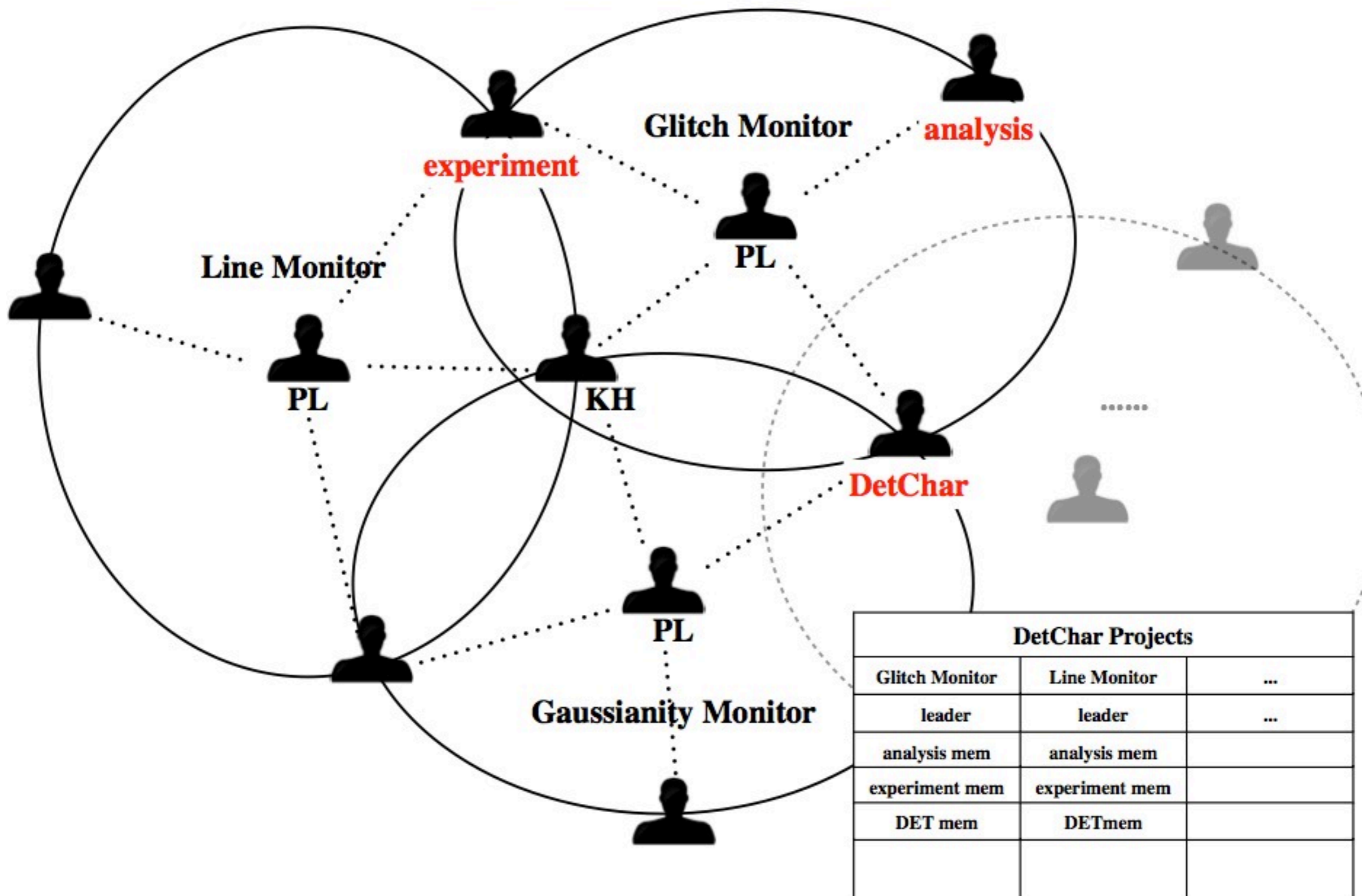

# Noise Characterization

## What about Seismic Up-Conversion Noise ?

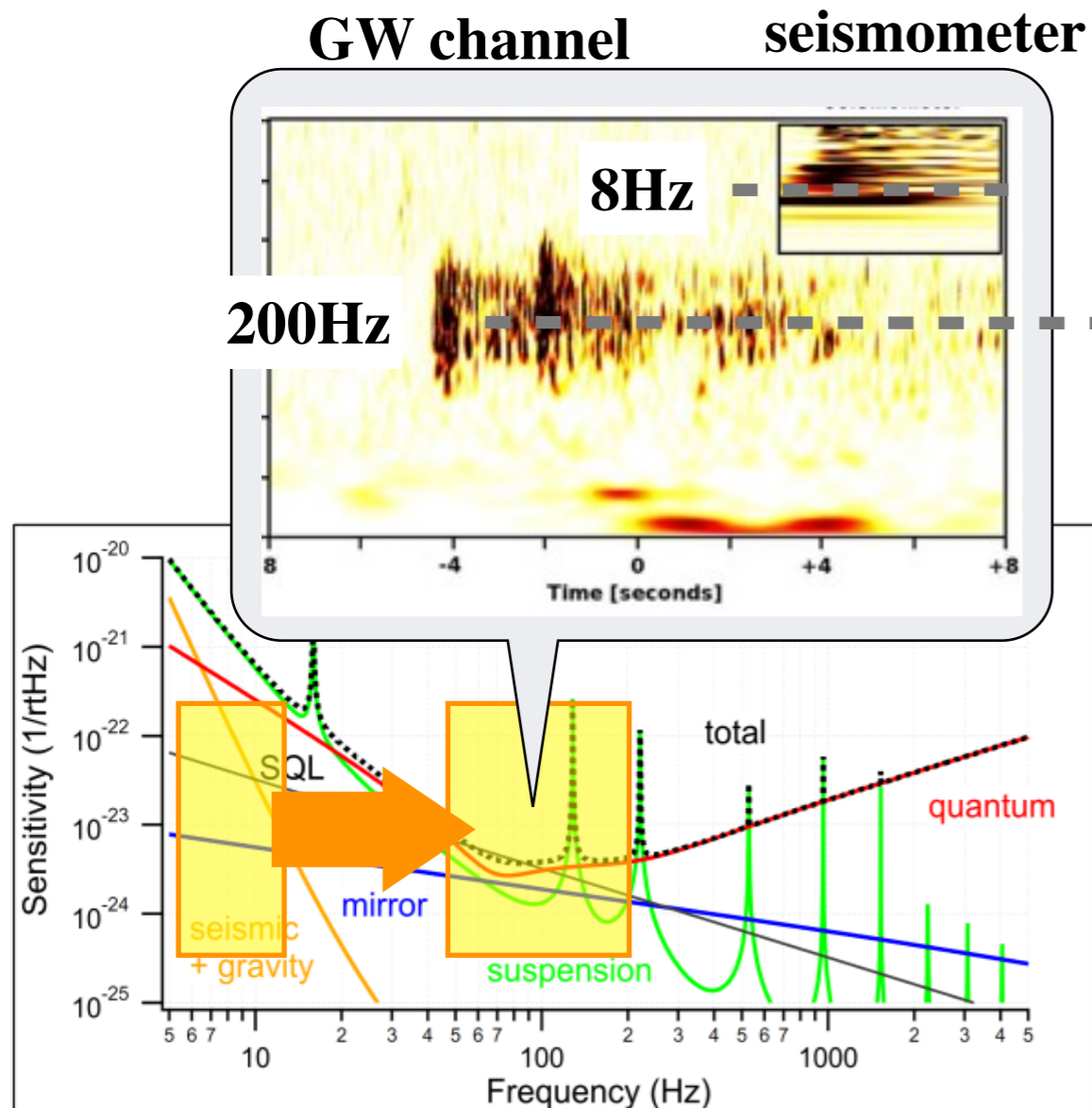

Sensitivity curve of KAGRA

## How magnetic field affects KAGRA?

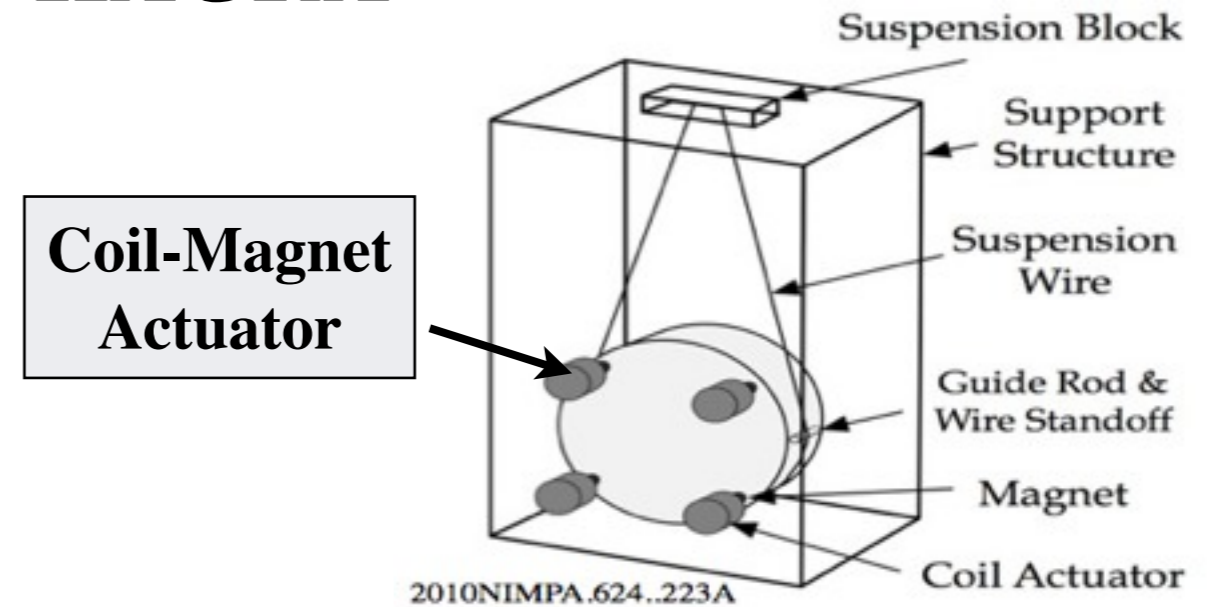

## Globally correlated noise

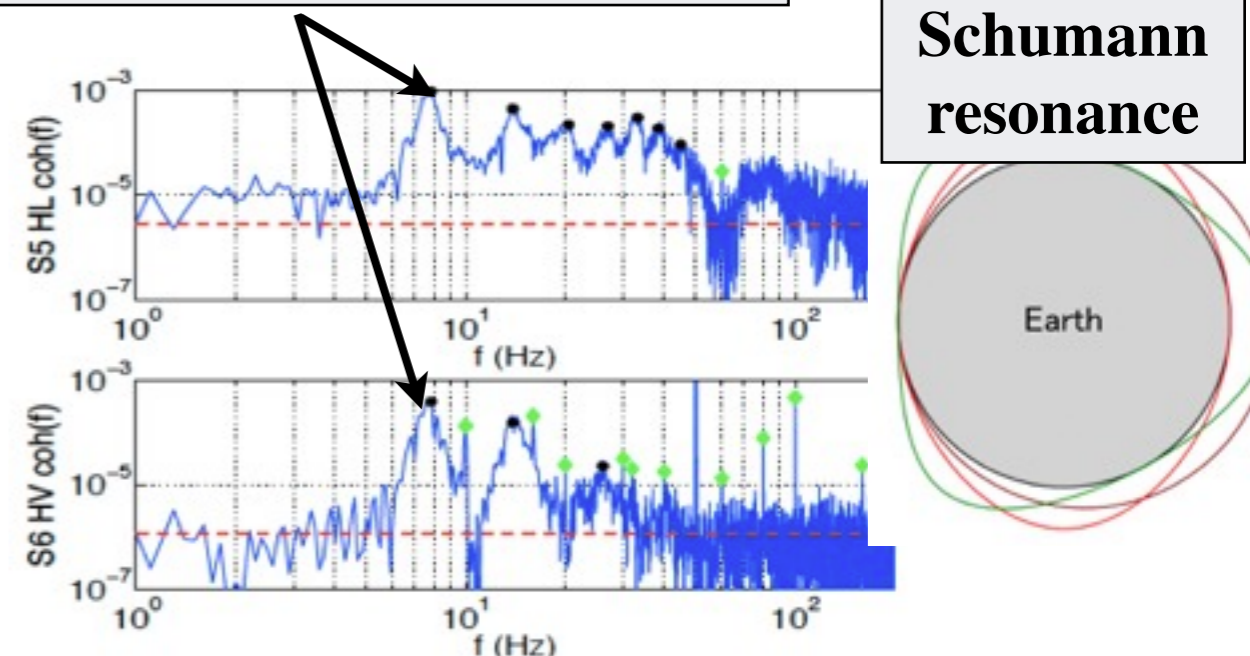



# Location of the measurement



# Rana's Comment at External Review



DetChar:

1) A way to maximize the utility of DetChar in speeding the commissioning progress in the early days is for the commissioning team to construct well-defined start-up projects for the DetChar team. An example of one created for LIGO is here:

[https://nodus.ligo.caltech.edu:30889/wiki/doku.php?id=detector\\_commissioning\\_characterization\\_projects](https://nodus.ligo.caltech.edu:30889/wiki/doku.php?id=detector_commissioning_characterization_projects)

2) It would be helpful to have remote interferometer experts able to do remote monitoring and data analysis during the commissioning phase. Will there be remote data mirrors, data access, workstations?