

Interferometer Photo Detector Circuit

(2012/5/24 麻生氏提供の受光パワー・データ(再計算値)による)

2012/5/31

平松成範

Circuit : GEO600_1b ($f_0=16.811\text{MHz}$: $C_{pd}=50\text{pF}$, $L_1=0.82\mu\text{H}$, $C_1=108.4\text{pF}$, $R_1=10\Omega$)

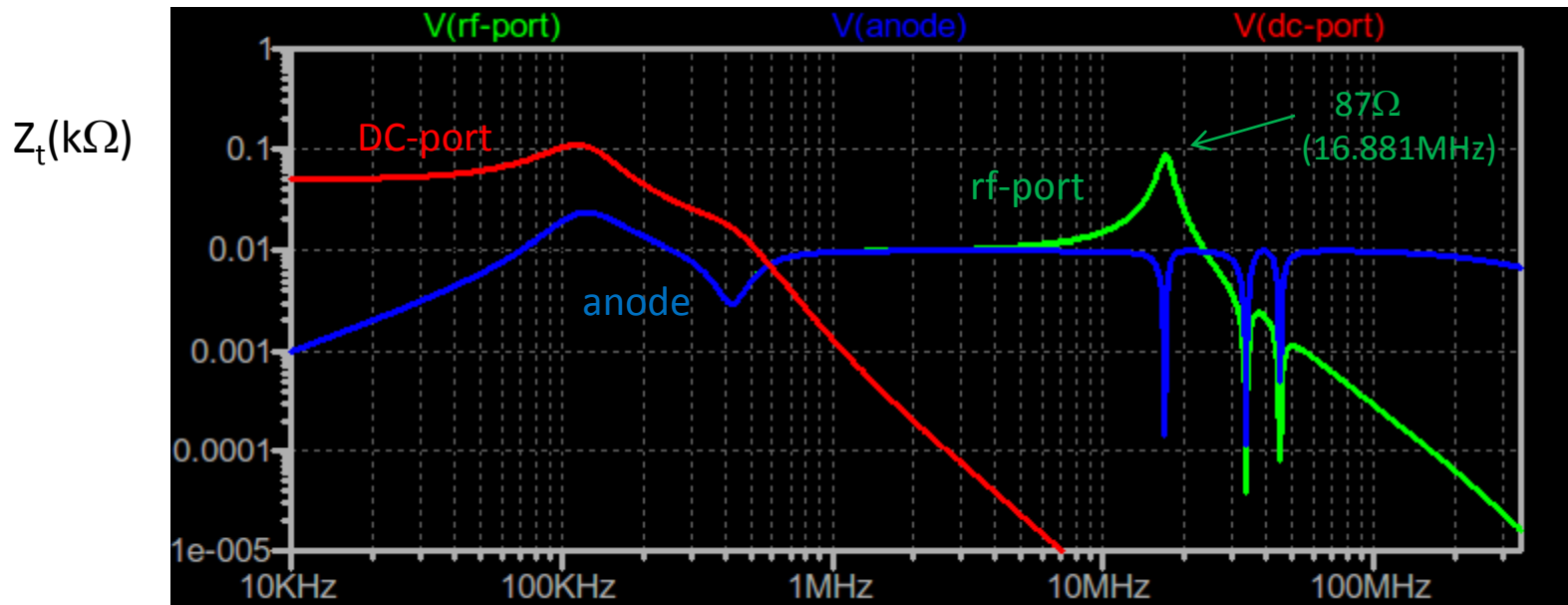
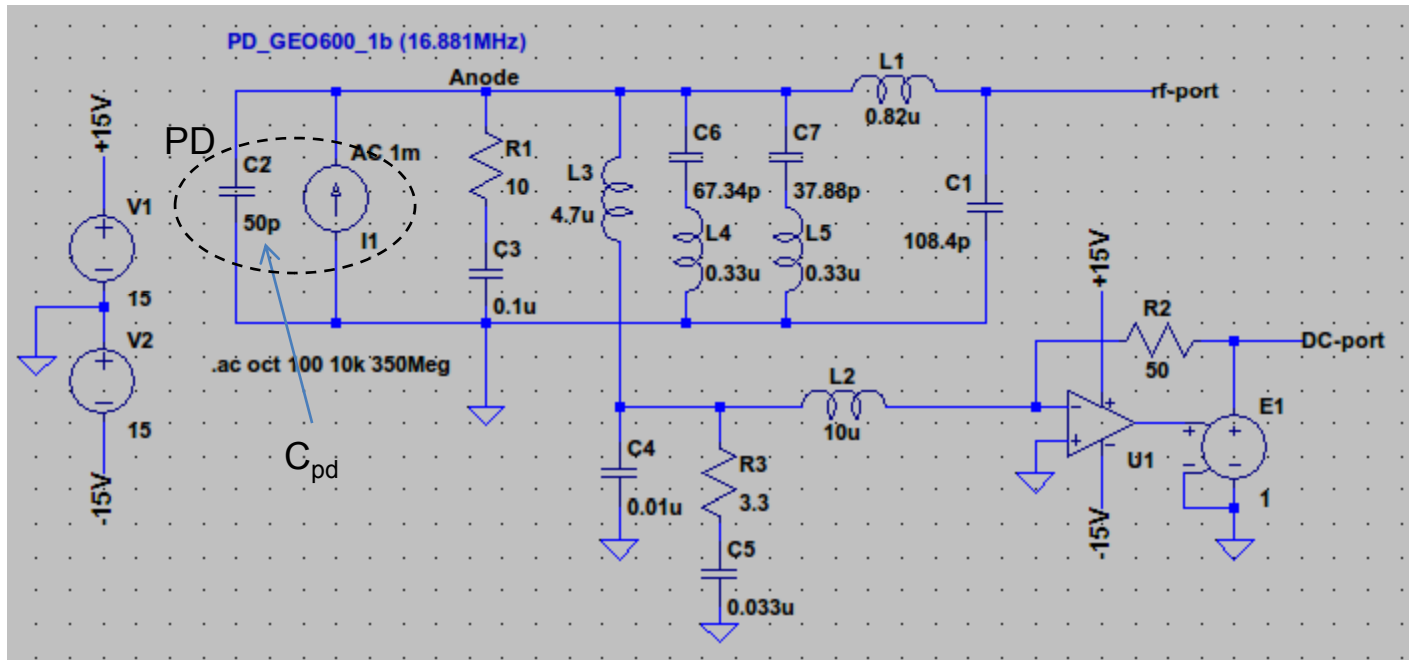

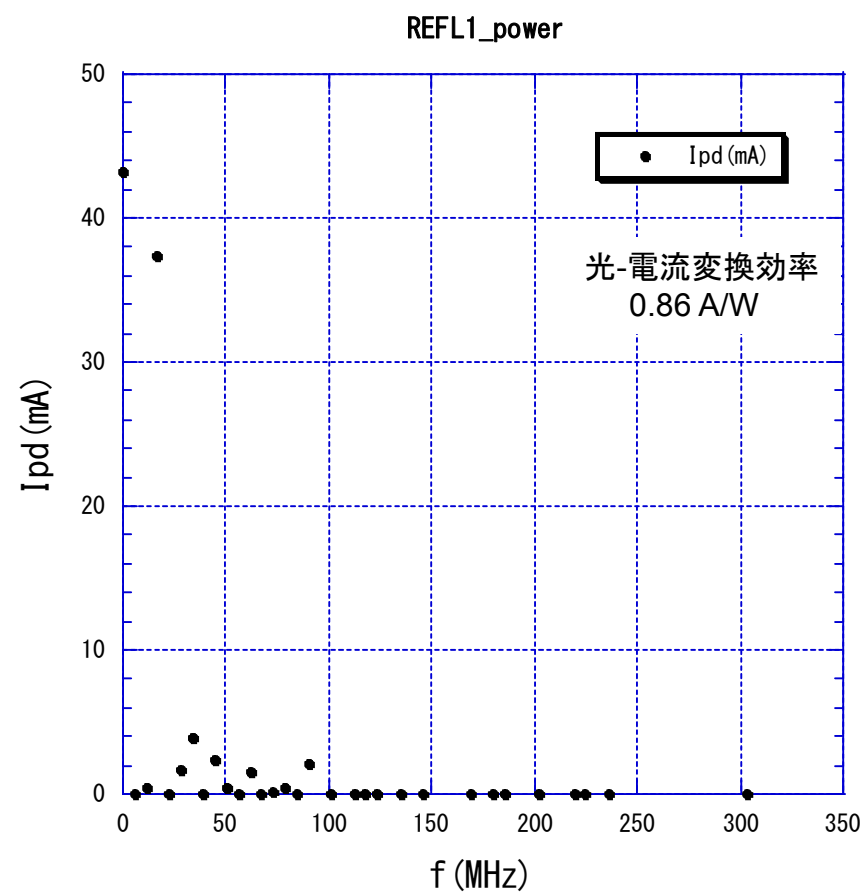
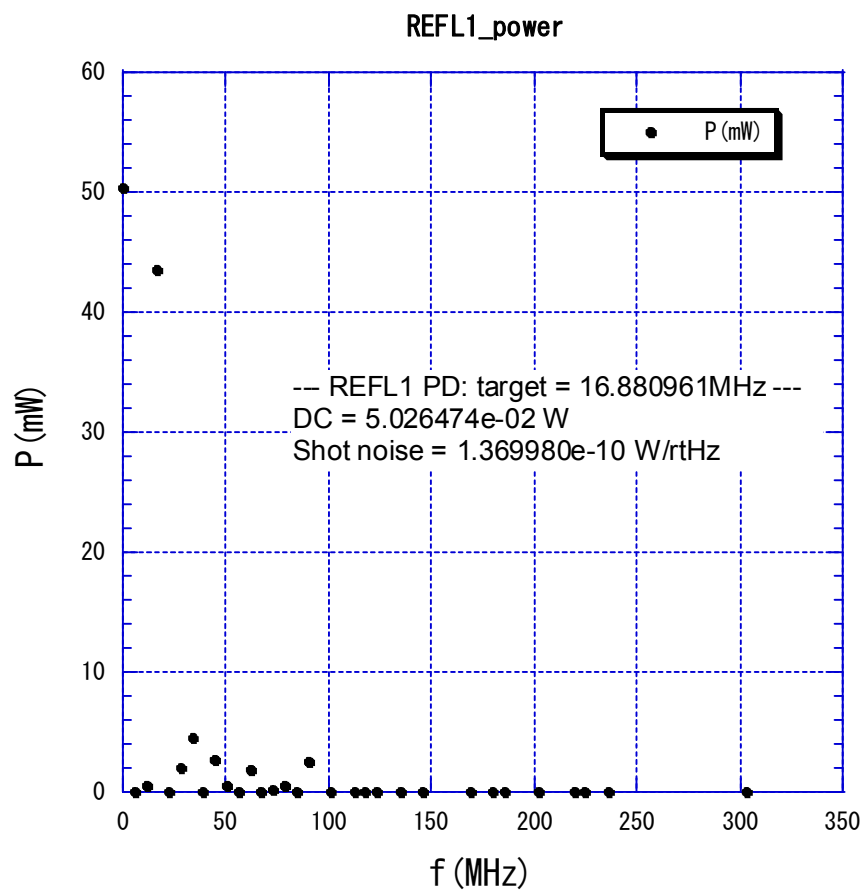

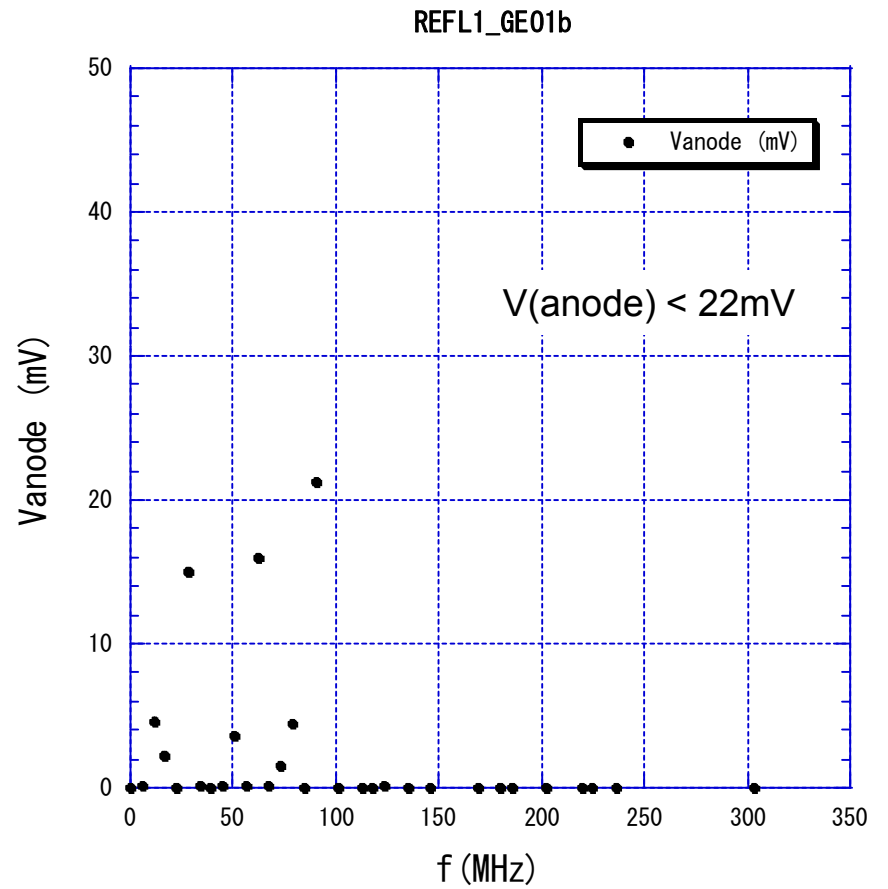
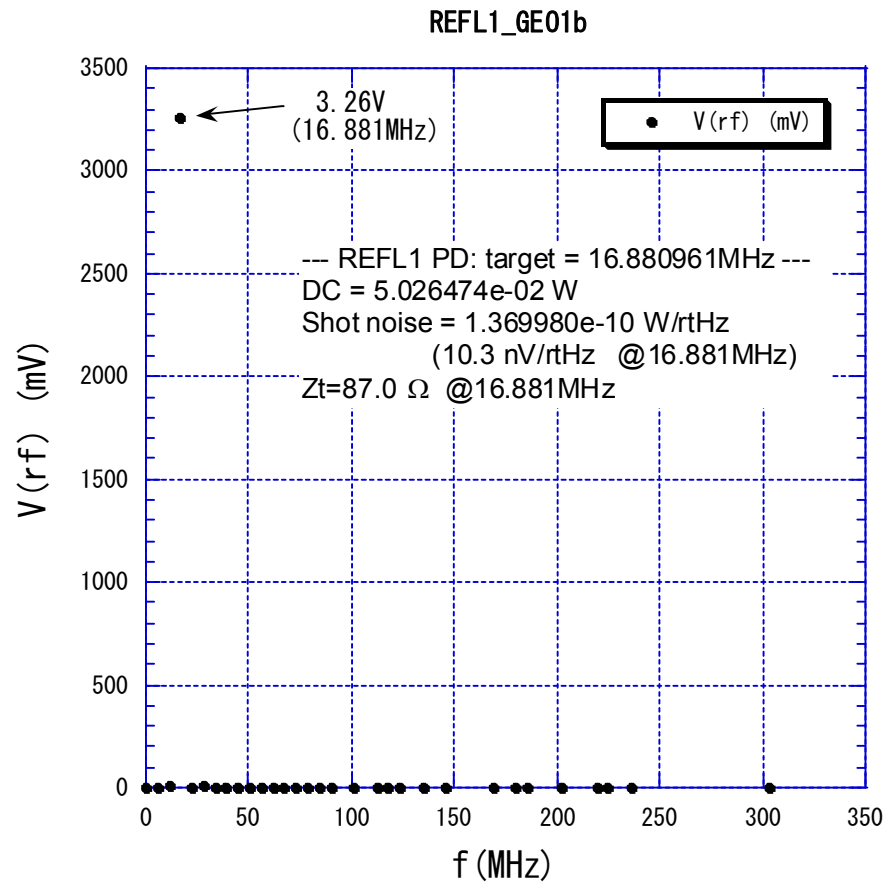

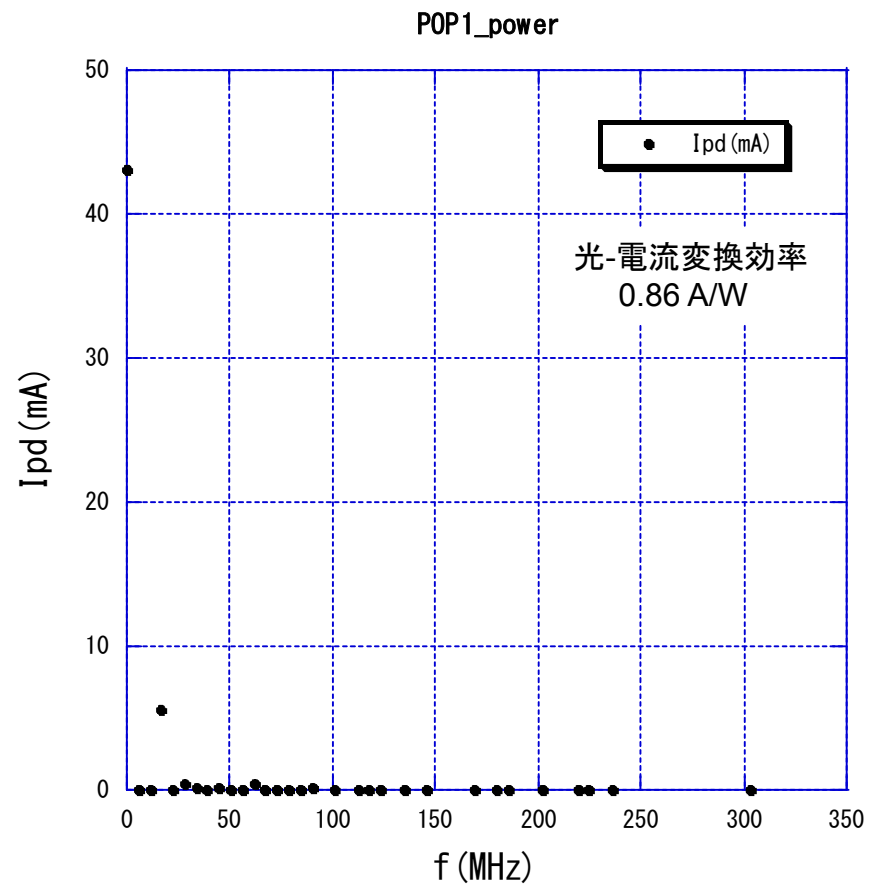
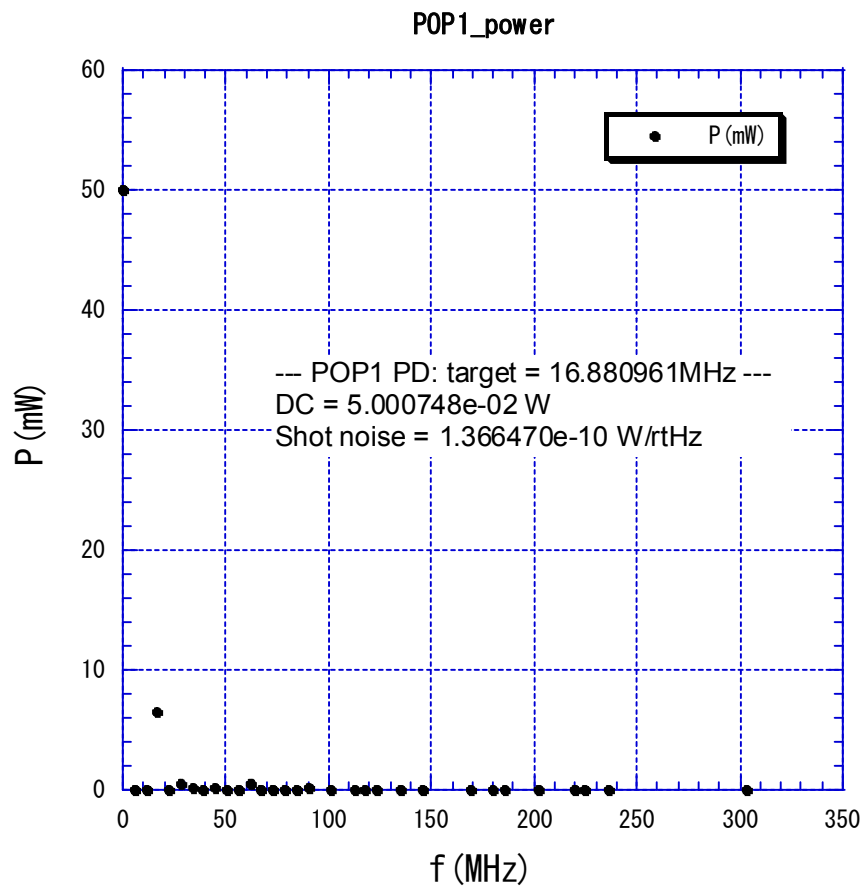

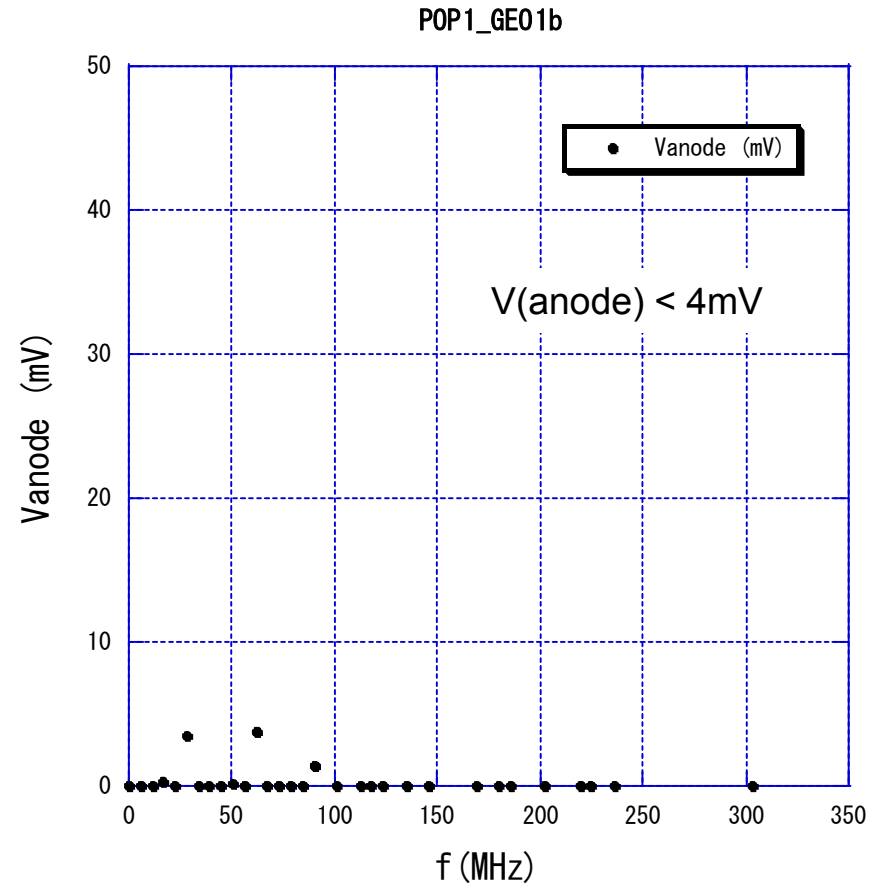
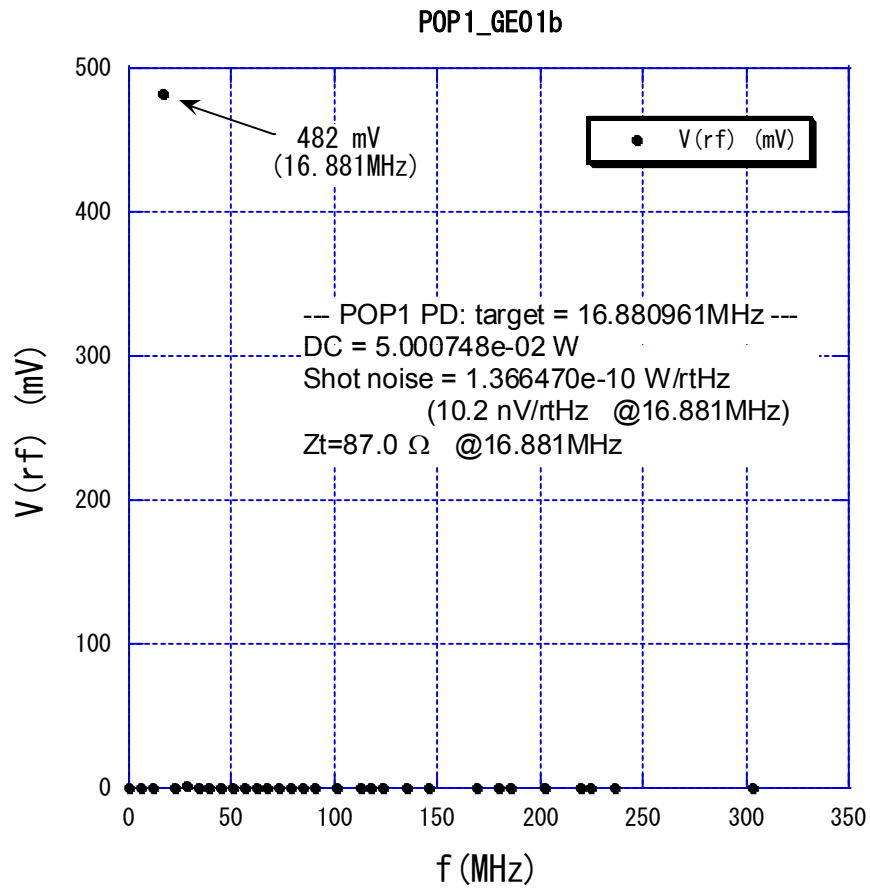

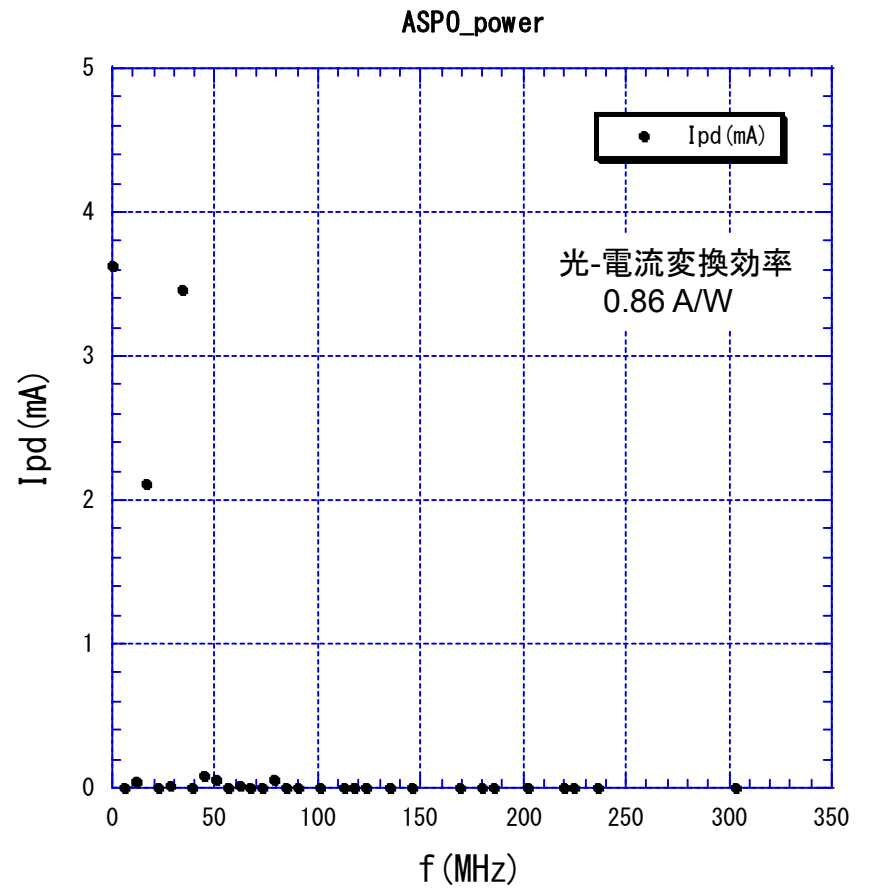
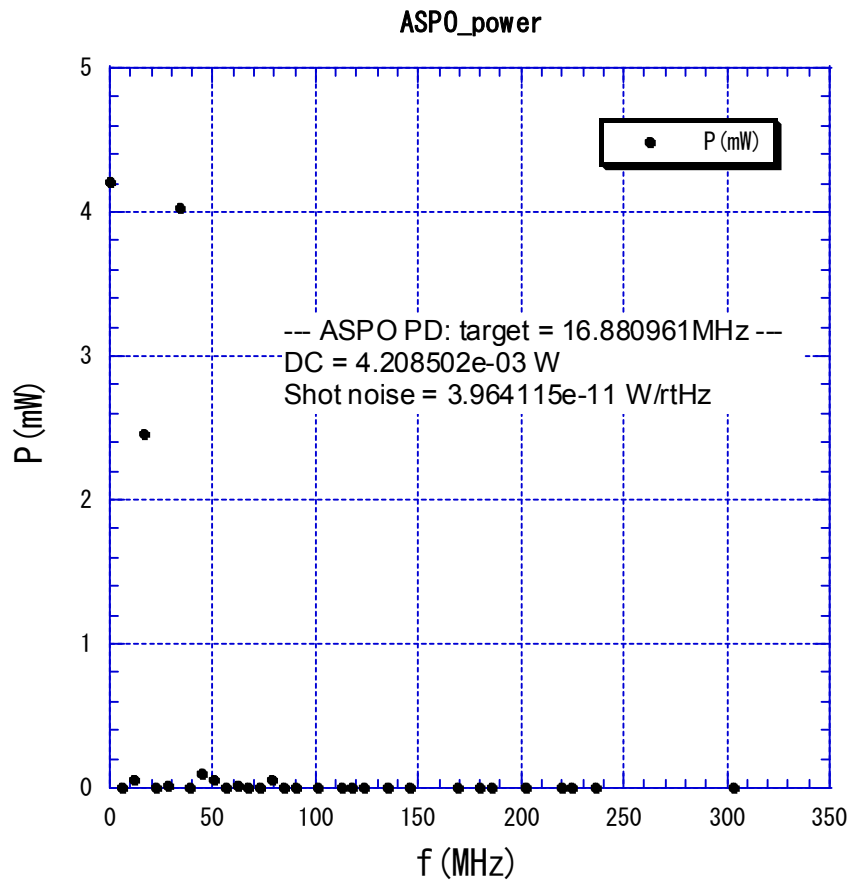

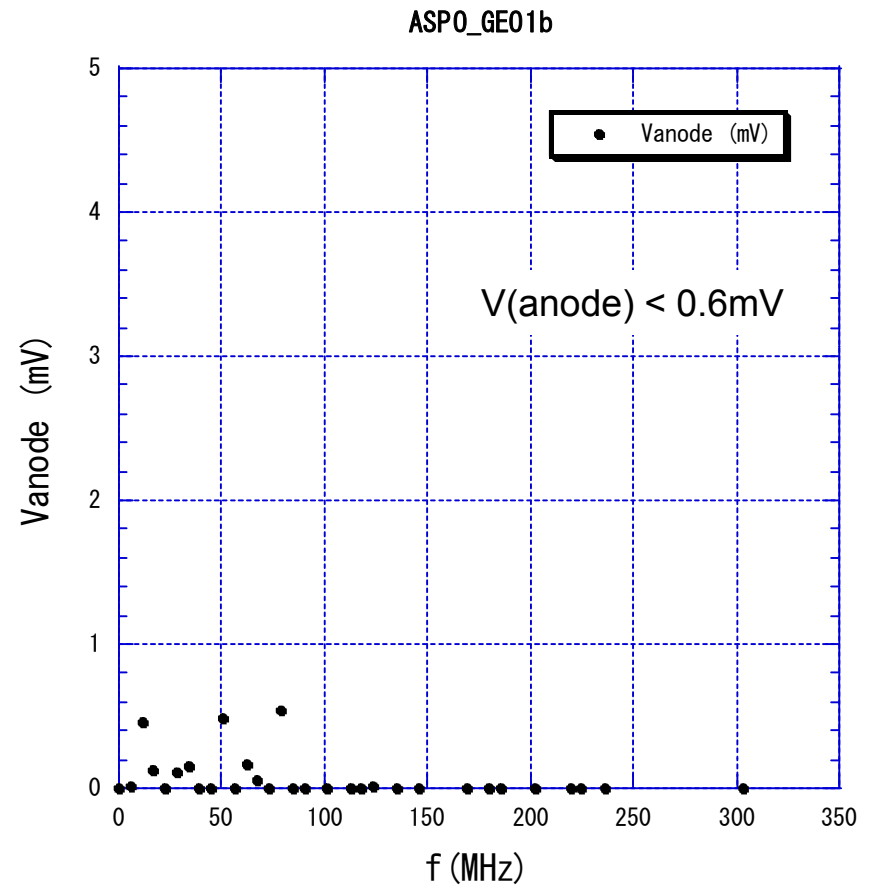
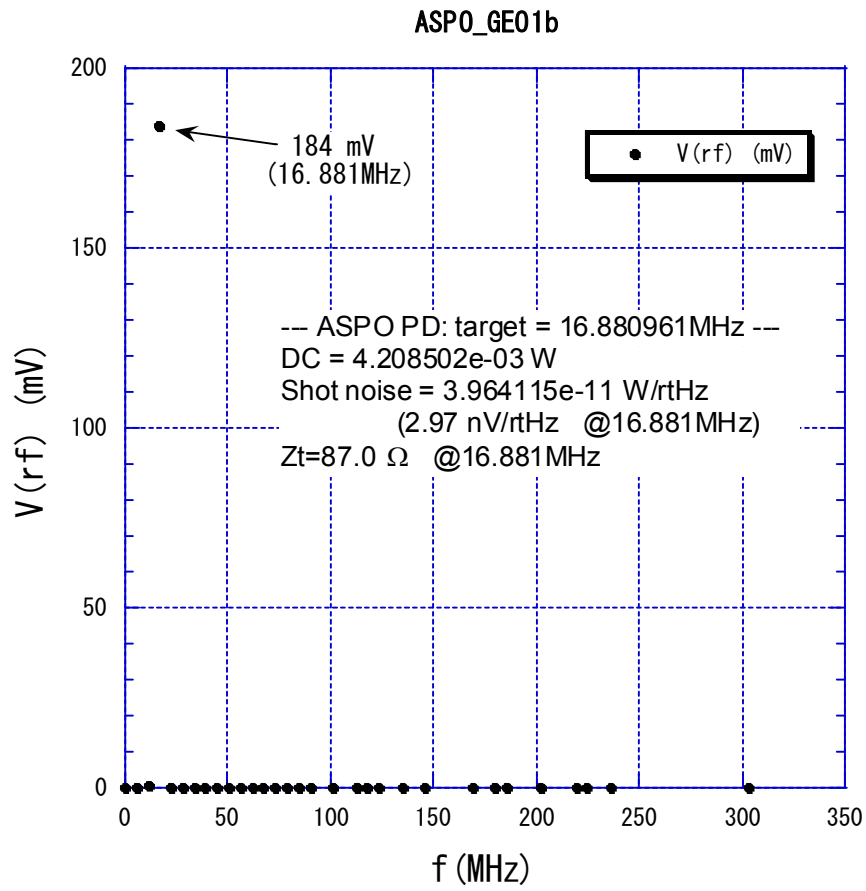

Circuit : GEO600_3a ($f_0=45.016\text{MHz}$: $C_{pd}=50\text{pF}$, $L_1=0.82\mu\text{H}$, $C_1=108.4\text{pF}$, $R_1=10\Omega$)

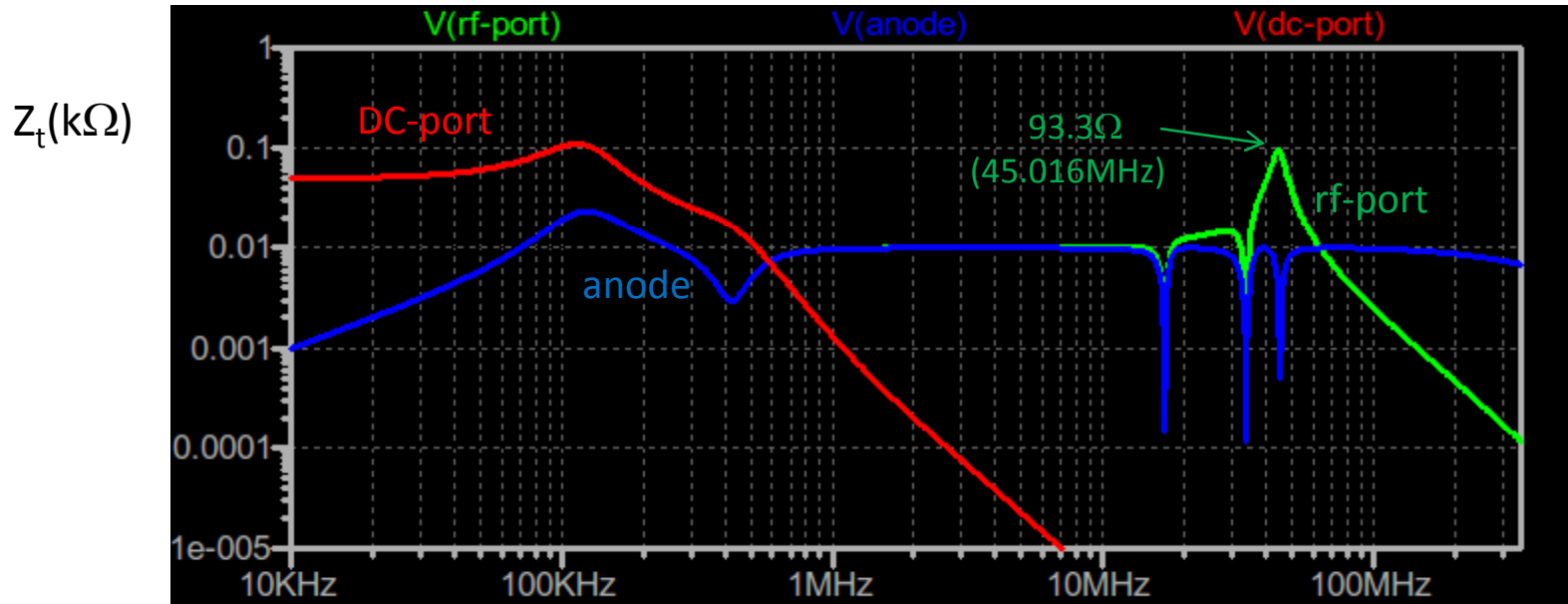
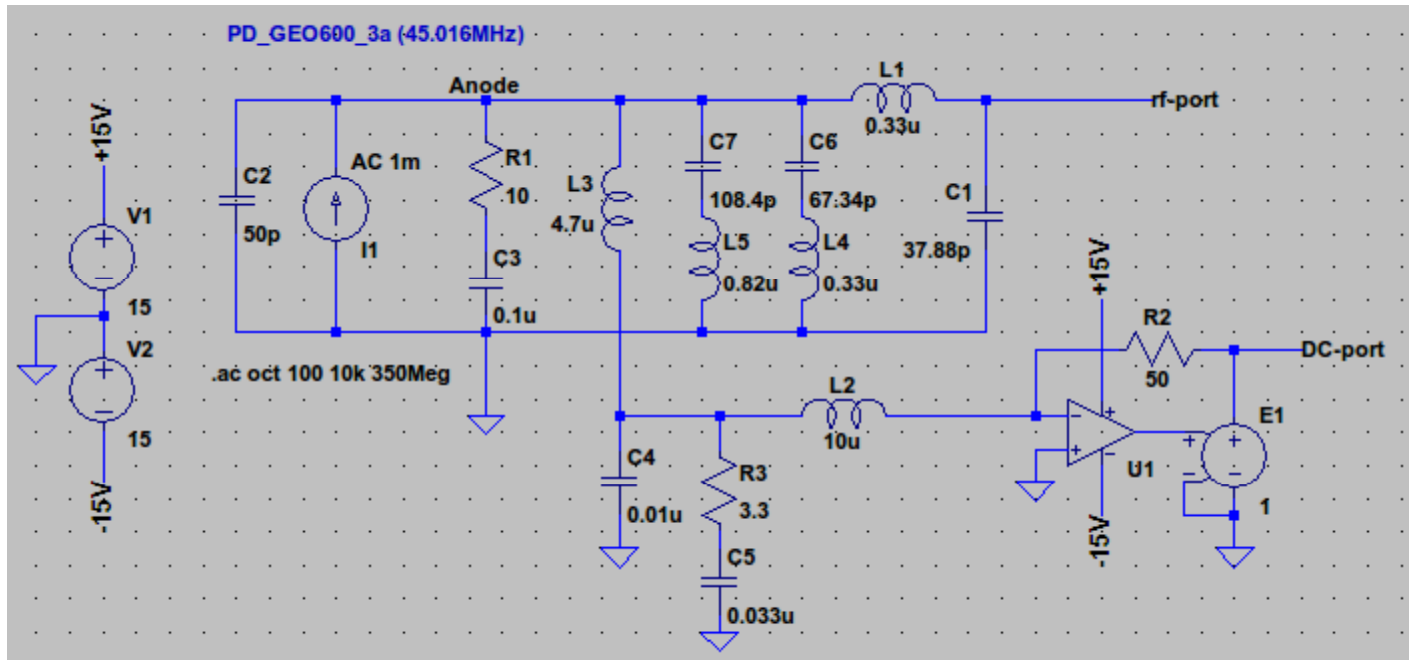

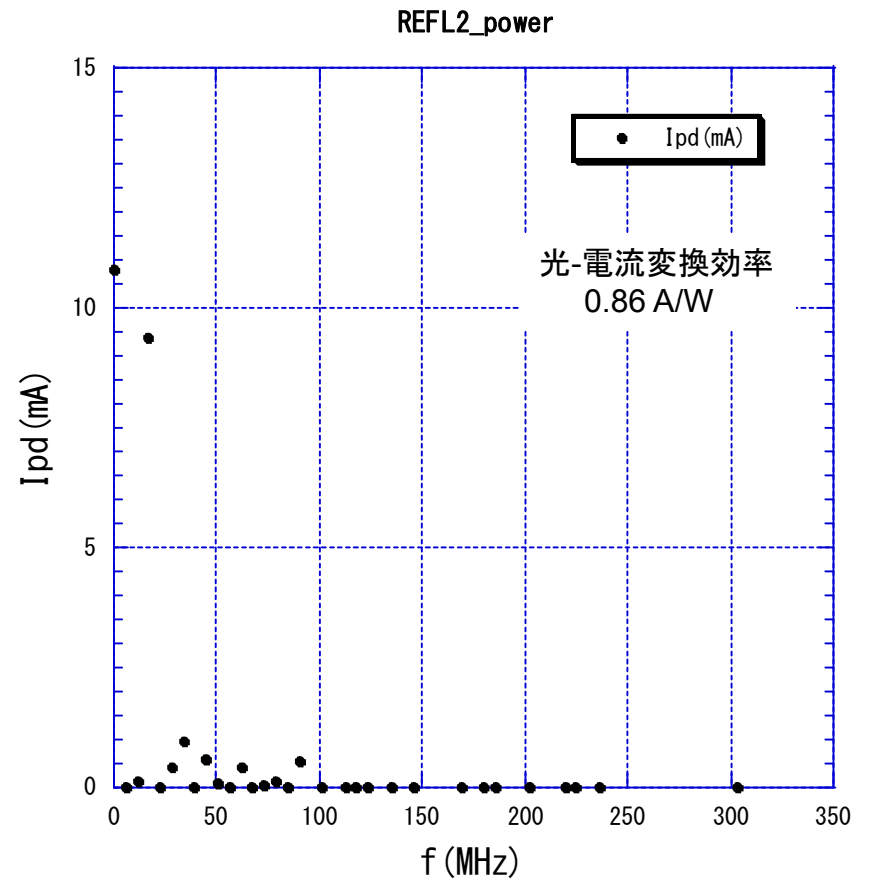
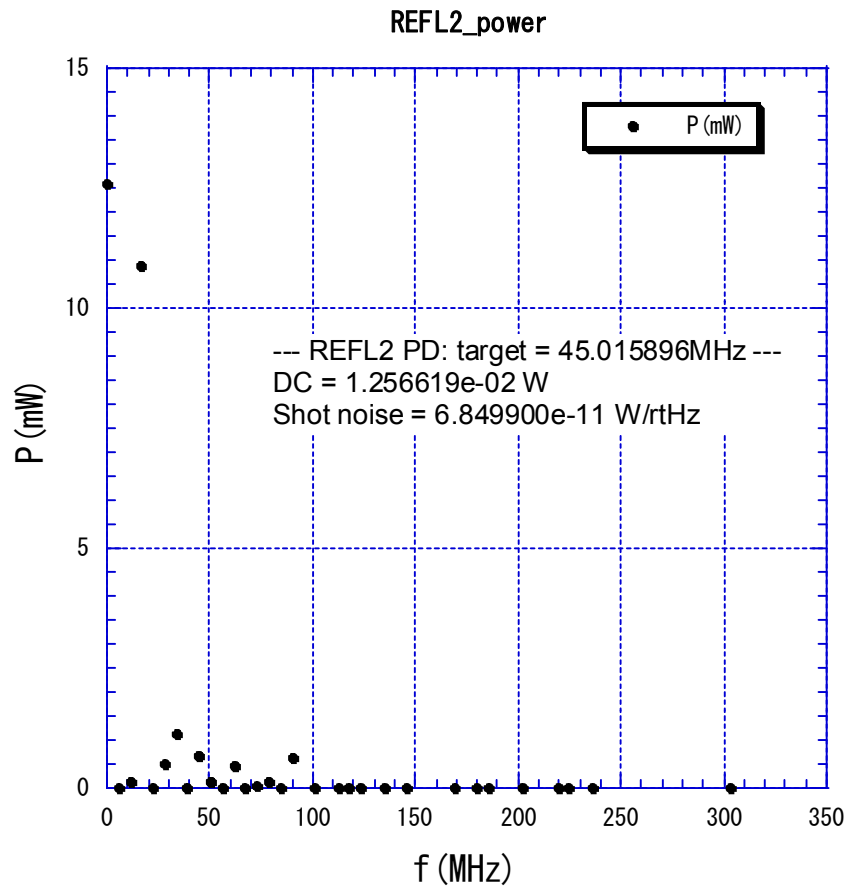

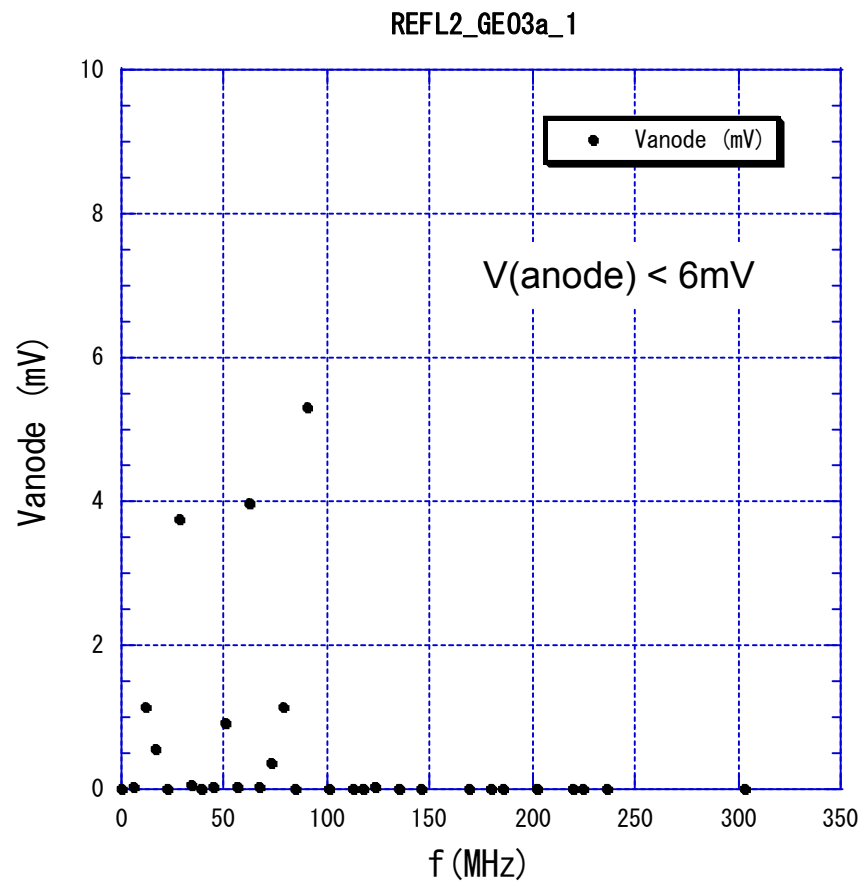
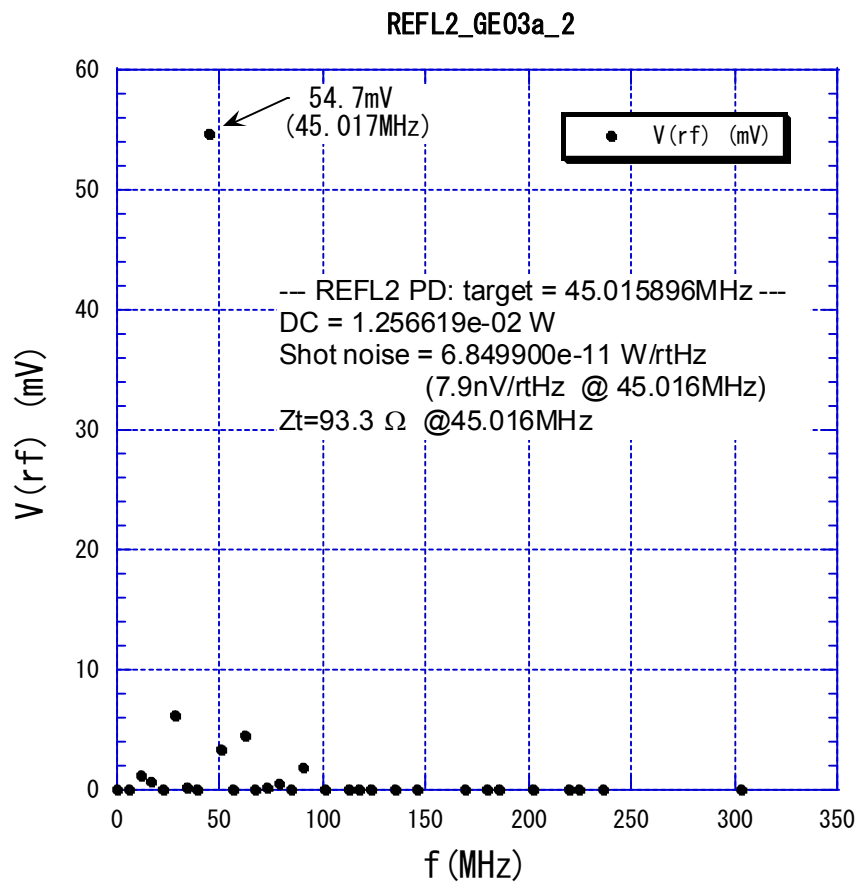

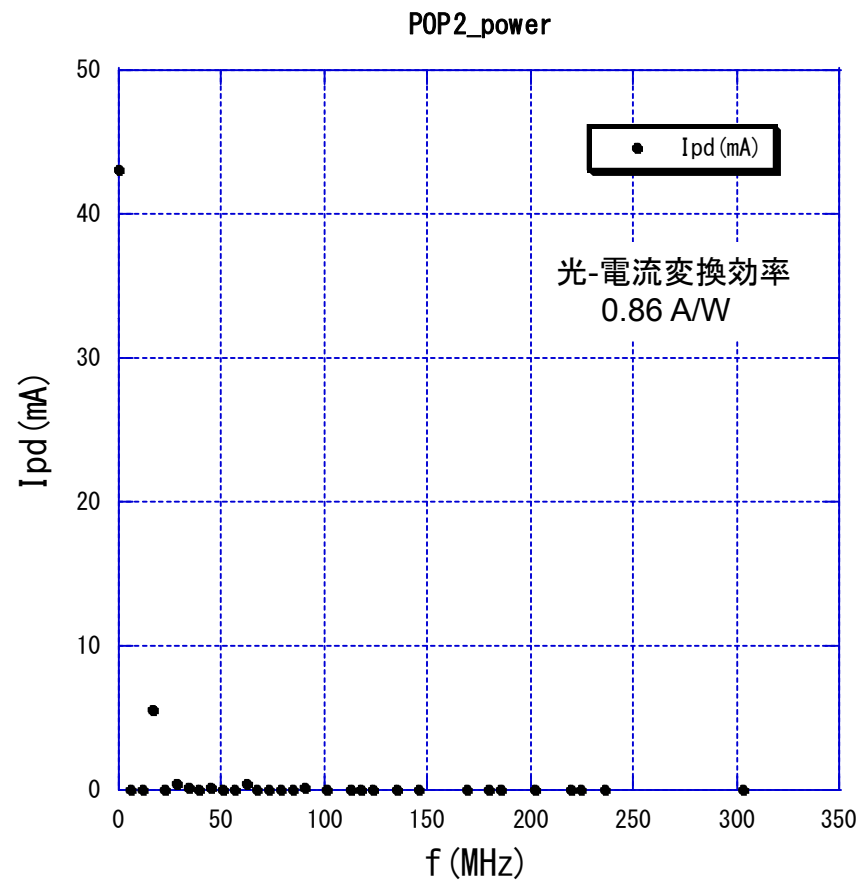
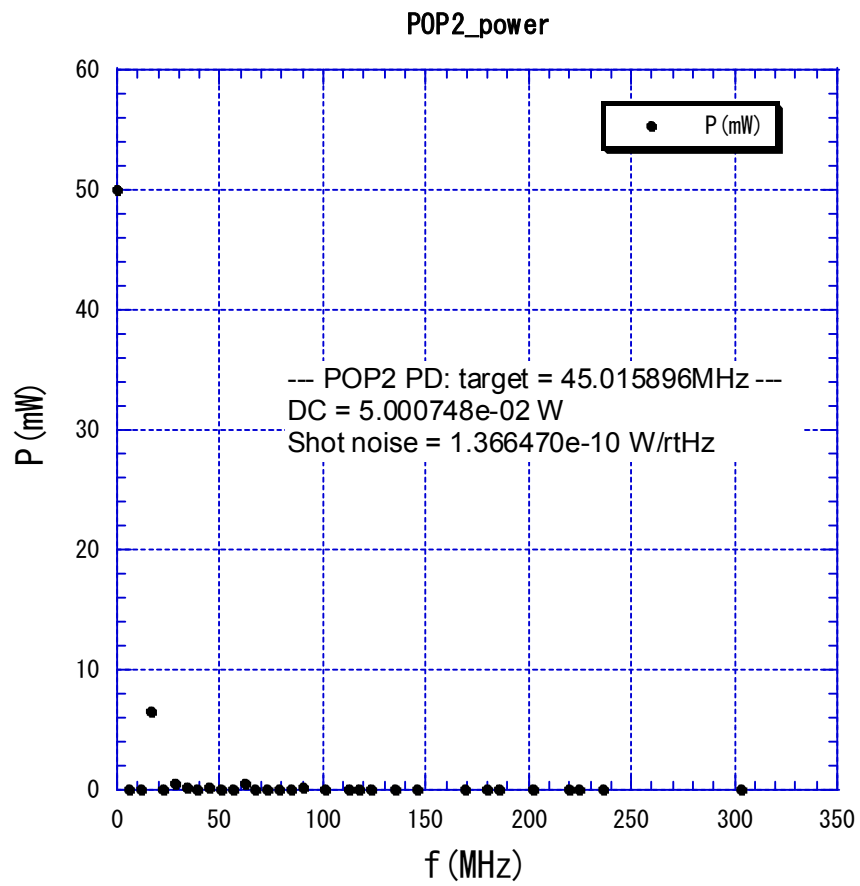

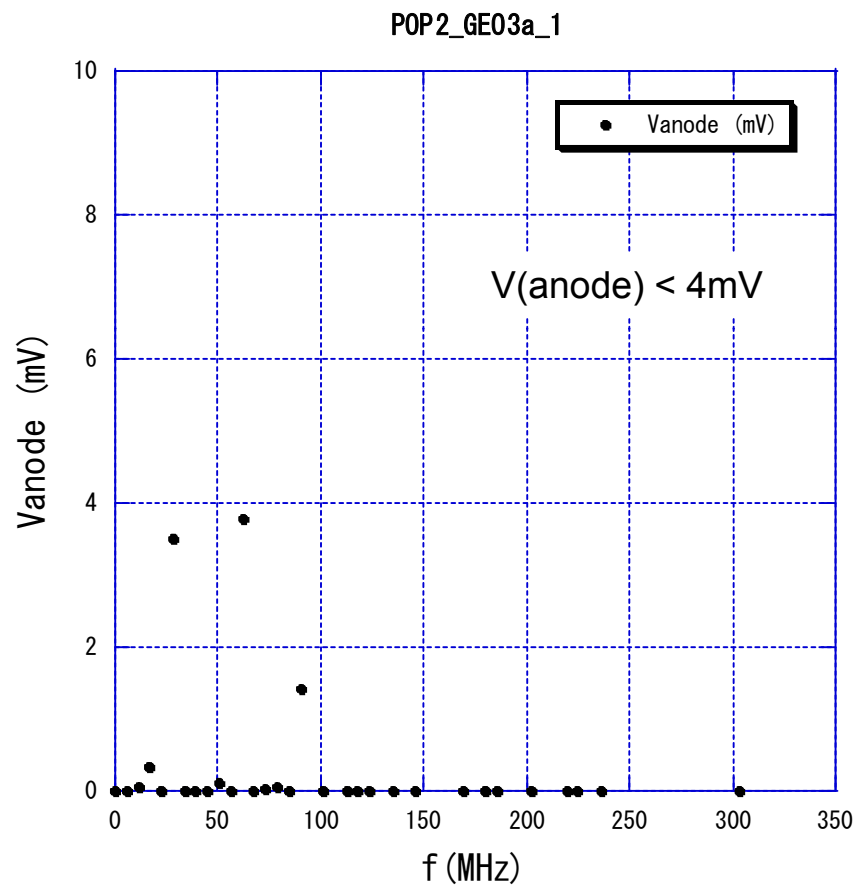
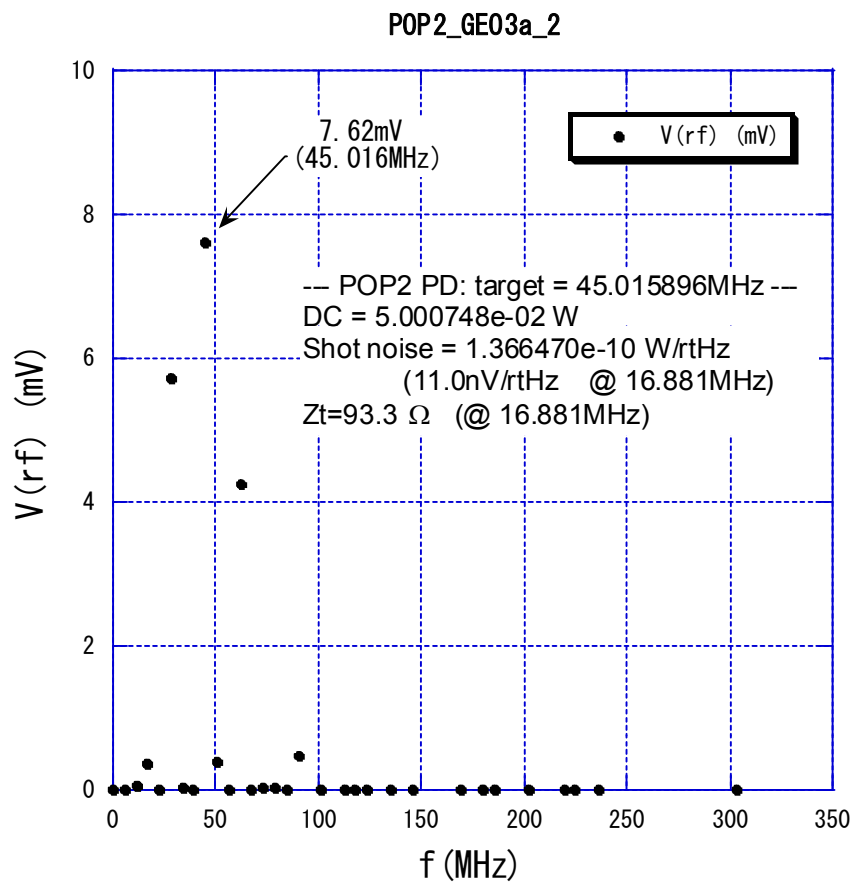

まとめ

Target freq.
(circuit resonance freq.)

rf-port 出力用 OP1 の入力
換算雑音はこれより十分小さい
ことが望まれる

$R_1 = 10 \Omega$
(Appendix B 参照)

PD	circuit	f_0 (MHz)	P (DC) (mW)	P (at f_0) (mW)	Zt (at f_0) (Ω)	V(rf) (mV)	Shot noise (nV/rtHz)	Thermal noise (nV/rtHz)
REFL1	GEO600_1b (p.2)	16.881	50.265	43.530	87.0	3260	10.3	3.55
REFL2	GEO600_3a (p.9)	45.016	12.566	0.6814	93.3	54.7	5.50	3.80
POP1	GEO600_1b (p.2)	16.881	50.007	6.4403	87.0	482	10.2	3.55
POP2	GEO600_3a (p.9)	45.016	50.007	0.0949	93.3	7.62	11.0	3.80
ASPO	GEO600_1b (p.2)	16.881	4.2085	2.4595	87.0	184	2.97	3.55

GEO600_1b : $L1=0.82\mu\text{H}$, $C1=108.4\text{pF}$, $R1=10\Omega$

GEO600_3a : $L1=0.33\mu\text{H}$, $C1=37.88\text{pF}$, $R1=10\Omega$

at f_0

REFL1, ASPO は回路定数の変更可(次ページ表)

注: 2012/5/24 麻生氏提供の受光パワー・データ(再計算値)による

まとめ(続)

REF1, ASPO の回路定数変更

PD	L1 C1	R1	f_0 (MHz)	Zt (at f_0) (Ω)	V(rf) (mV)	Shot noise (nV/rtHz)	Thermal noise (nV/rtHz)	V(DC) (V)
REFL1	0.68 μ H 130.7pF	20 Ω	16.881	72.1	2700	8.54	2.07	2.16
REFL2	GEO600_3a		45.016	93.3	54.7	5.50	3.80	0.540
POP1	GEO600_1b		16.881	87.0	482	10.2	3.55	2.15
POP2	GEO600_3a		45.016	93.3	7.62	11.0	3.80	2.15
ASPO	1.5 μ H 59.3pF	20 Ω	16.881	159	337	5.43	4.58	0.181

$\omega C_{pd} R_1 \ll 1$ なる条件のもとでは、REFL2, POP2 (共振周波数45.016MHz) は変更の余地なし

Appendix A 受光パワー (2012/5/26 麻生氏提供)

--- REFL1 PD: target = 16.880961MHz ---

DC = 5.026474e-02 W

Shot noise = 1.369980e-10 W/rtHz

f(MHz), P(W)

5.626987, 1.100485e-05
11.253974, 5.455531e-04
16.880961, 4.352951e-02
22.507948, 1.094440e-06
28.134935, 1.929028e-03
33.761922, 4.533192e-03
39.388909, 2.682817e-07
45.015896, 2.725535e-03
50.642883, 4.731386e-04
56.269870, 1.634270e-05
61.896857, 1.863028e-03
67.523844, 1.356901e-05
73.150831, 1.746389e-04
78.777818, 5.256557e-04
84.404805, 4.551461e-07
90.031792, 2.489756e-03
101.285766, 1.606858e-07
112.539740, 5.254366e-07
118.166727, 5.084316e-06
123.793714, 1.395871e-05
135.047688, 2.613296e-07
146.301662, 2.815484e-09
168.809610, 6.881434e-08
180.063584, 3.166540e-07
185.690571, 5.472501e-09
202.571532, 1.379237e-10
219.452493, 4.854554e-12
225.079480, 1.203652e-11
236.333454, 1.963254e-13
303.857298, 1.287535e-13

--- REFL2 PD: target = 45.015896MHz ---

DC = 1.256619e-02 W

Shot noise = 6.849900e-11 W/rtHz

f(MHz), P(W)

5.626987, 2.751213e-06
11.253974, 1.363883e-04
16.880961, 1.088238e-02
22.507948, 2.736100e-07
28.134935, 4.822570e-04
33.761922, 1.133298e-03
39.388909, 6.707042e-08
45.015896, 6.813838e-04
50.642883, 1.182846e-04
56.269870, 4.085675e-06
61.896857, 4.657570e-04
67.523844, 3.392252e-06
73.150831, 4.365973e-05
78.777818, 1.314139e-04
84.404805, 1.137865e-07
90.031792, 6.224390e-04
101.285766, 4.017145e-08
112.539740, 1.313591e-07
118.166727, 1.271079e-06
123.793714, 3.489677e-06
135.047688, 6.533240e-08
146.301662, 7.038710e-10
168.809610, 1.720358e-08
180.063584, 7.916350e-08
185.690571, 1.368125e-09
202.571532, 3.448092e-11
219.452493, 1.213639e-12
225.079480, 3.009130e-12
236.333454, 4.908134e-14
303.857298, 3.218838e-14

--- POP1 PD: target = 16.880961MHz ---

DC = 5.000748e-02 W

Shot noise = 1.366470e-10 W/rtHz

f(MHz), P(W)

5.626987, 7.733593e-07
11.253974, 6.039889e-06
16.880961, 6.440286e-03
22.507948, 2.040181e-08
28.134935, 4.493085e-04
33.761922, 2.300804e-04
39.388909, 4.504155e-09
45.015896, 9.489546e-05
50.642883, 1.318496e-05
56.269870, 1.099829e-07
61.896857, 4.421604e-04
67.523844, 1.402968e-06
73.150831, 3.098277e-06
78.777818, 6.514071e-06
84.404805, 3.025908e-09
90.031792, 1.672568e-04
101.285766, 3.032683e-09
112.539740, 4.144640e-09
118.166727, 1.807938e-07
123.793714, 1.340232e-07
135.047688, 9.448349e-09
146.301662, 2.201989e-11
168.809610, 1.844614e-09
180.063584, 3.277850e-08
185.690571, 1.384629e-10
202.571532, 9.287771e-13
219.452493, 1.327265e-13
225.079480, 2.499132e-13
236.333454, 4.489983e-16
303.857298, 5.767589e-16

--- POP2 PD: target = 45.015896MHz ---

DC = 5.000748e-02 W

Shot noise = 1.366470e-10 W/rtHz

f(MHz), P(W)

5.626987, 7.733593e-07
11.253974, 6.039889e-06
16.880961, 6.440286e-03
22.507948, 2.040181e-08
28.134935, 4.493085e-04
33.761922, 2.300804e-04
39.388909, 4.504155e-09
45.015896, 9.489546e-05
50.642883, 1.318496e-05
56.269870, 1.099829e-07
61.896857, 4.421604e-04
67.523844, 1.402968e-06
73.150831, 3.098277e-06
78.777818, 6.514071e-06
84.404805, 3.025908e-09
90.031792, 1.672568e-04
101.285766, 3.032683e-09
112.539740, 4.144640e-09
118.166727, 1.807938e-07
123.793714, 1.340232e-07
135.047688, 9.448349e-09
146.301662, 2.201989e-11
168.809610, 1.844614e-09
180.063584, 3.277850e-08
185.690571, 1.384629e-10
202.571532, 9.287771e-13
219.452493, 1.327265e-13
225.079480, 2.499132e-13
236.333454, 4.489983e-16
303.857298, 5.767589e-16

--- ASPO PD: target = 16.880961MHz ---

DC = 4.208502e-03 W

Shot noise = 3.964115e-11 W/rtHz

f(MHz), P(W)

5.626987, 1.241853e-06
11.253974, 5.505002e-05
16.880961, 2.459520e-03
22.507948, 5.904967e-08
28.134935, 1.523102e-05
33.761922, 4.022986e-03
39.388909, 2.609744e-08
45.015896, 9.510846e-05
50.642883, 6.302600e-05
56.269870, 8.259401e-07
61.896857, 1.931459e-05
67.523844, 5.876853e-06
73.150831, 5.929963e-07
78.777818, 6.283580e-05
84.404805, 2.420282e-08
90.031792, 5.821271e-07
101.285766, 1.368103e-08
112.539740, 5.183023e-08
118.166727, 1.998011e-09
123.793714, 1.122259e-06
135.047688, 1.547713e-08
146.301662, 9.693689e-11
168.809610, 5.734567e-11
180.063584, 1.889478e-10
185.690571, 8.266513e-10
202.571532, 1.583382e-11
219.452493, 1.158499e-13
225.079480, 1.728828e-15
236.333454, 1.130181e-14
303.857298, 1.152063e-17

Appendix B 等価回路

B点(OP1入力)までの等価回路、トラップは省略

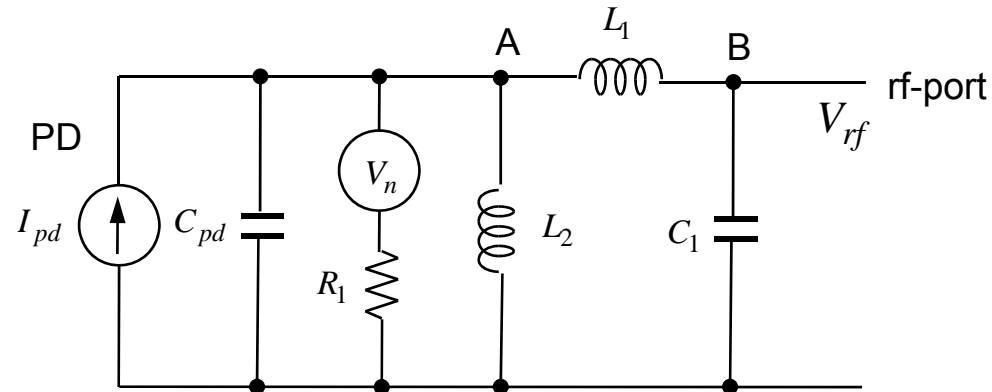

$$V_A(\omega) = Z_t^{anode}(\omega)(I_{pd} + V_n / R_1)$$

$$V_B(\omega) = Z_t^{rf}(\omega)(I_{pd} + V_n / R_1)$$

$$Z_t^{rf}(\omega) = \frac{j\omega L_2}{1 - \omega^2(L_1 + L_2)C_1 + (j\omega L_2 / R_1)(1 - \omega^2 L_1 C_1)(1 + j\omega C_{pd} R_1)}$$

$$Z_t^{anode}(\omega) = Z_t^{rf}(\omega)(1 - \omega^2 L_1 C_1)$$

$Z_t^{anode}(\omega)$ は I_{pd} に対するA点における伝達インピーダンス(trans-impedance)

$Z_t^{rf}(\omega)$ は I_{pd} に対するB点における伝達インピーダンス(trans-impedance)

* L_1 、 C_1 の共振周波数 $\omega = \omega_0 = 1/\sqrt{L_1 C_1}$ では、共振の Q 値

$$Q = \frac{\omega_0 L_1}{R_1} = \frac{1}{\omega_0 C_1 R_1}$$

を用いて

$$Z_t^{rf}(\omega_0) = QR_1 = 1/\omega_0 C_1 = \omega_0 L_1 \quad (Z_t^{rf}(\omega_0) \text{ は } L_1 \text{ または } C_1 \text{ のみで決まる})$$

$$V_{rf}(\omega_0) = -jZ_t^{rf}(\omega_0)I_{pd} - jQV_n$$

となる。

* L_1 、 C_1 の共振特性を乱さないためには

$$\omega C_{pd} R_1 \ll 1$$

であることが必要 ($C_{pd} = 50 \text{ pF}$, $R_1 = 10 \Omega \rightarrow \omega C_{pd} R_1 = 0.157 \text{ (at } 50 \text{ MHz)}$)

$R_1 > 15 \Omega$ では C_{pd} の影響による共振周波数のずれが顕著になる

* V_n を R_1 の抵抗熱雑音 $V_n = \sqrt{4kTR_1\Delta f}$ とすると

B点に生ずる熱雑音は

$$QV_n = \frac{Z_t^{rf}(\omega_0)}{R_1} V_n = Q\sqrt{4kTR_1\Delta f} \quad \text{である}$$

I_{pd} に対して熱雑音を下げるには QR_1 を大きくする $\rightarrow C_1$ が小さくなる
 $\rightarrow OP_1$ の入力容量の影響が大きくなる (あまり自由度はない)

$R_1 = 10 \Omega$  p.14