



KAMIOKA GRAVITATIONAL WAVE TELESCOPE

JGW- T1200931-v4

KAGRA

29 March 2012

Transport features of the KAGRA type-B seismic
attenuation chains and vacuum tanks.

Riccardo DeSalvo, Gianni Gennaro

Distribution of this document:

Public

This is an internal working note of the

***KAGRA* Large-scale Cryogenic Gravitational Wave Telescope Project.**

<http://gwcenter.icrr.u-tokyo.ac.jp/en//>

1 Introduction

The [seismic isolation of KAGRA](#) will be based on the SAS Seismic Attenuation System, the KAGRA recycler and beam splitter will use Type-B chains. Assembling and commissioning equipment inside the KAGRA [tunnels](#) has logistic difficulties, and result in a slower process. In addition the tight confines of the tunnel will limit the number of people working at any given time. Those people would be competing for the use of common instruments like the overhead cranes. In addition the KAGRA experimental halls will be ready rather late, any assembly and commissioning work that can be done externally will greatly accelerate the KAGRA commissioning. It is therefore important to do as much external pre-assembly and pre-commissioning as possible, store pre-assembled units as large and as complete as possible, ship them to the site as ready-to-fit units and limit the assembly in the tunnel to the minimum possible.

The safe transport of Virgo's payloads, with fused silica fibers, between Pisa and Roma, is the proof that complex structures, even much more delicate than the type-B towers, can be safely transported without damage or loss of tuning accuracy.

KAGRA's type-B towers are described in and the [Type-B design](#), the [design philosophy](#) and [3D images](#) are also available.

The type-B SAS seismic chains and payload have been designed and will be fully [assembled](#), [cabled](#), balanced, [tuned](#) and [tested](#) in a clean University laboratory. Unfortunately they are too large to be transported long distance in a single piece because the maximum truck height is 3.8 m (the tunnel height is 4 m at the apex), the Type-2 vacuum tanks are 4.7 m tall, and the Type-2 SAS chain inside is 5.3 m.

It is important to transport the chains in their vertical orientation.

For road transport the KAGRA type-B seismic attenuation units have to be broken down in sections transportable on trucks.

Transport features have to be engineered into the system to allow safe transport from the assembly laboratory to the Kamioka mine. The transport must preserve the UHV cleanliness of the shipped sections, as well as all balancing and tuning pre-performed.

The SAS structures are too tall to fit on a truck, and need transport stiffeners to keep the suspended parts from hitting the safety structures and get damaged.

The SAS chain will be separated in two halves and transported in clean tanks, each 1.7 m tall, from the laboratory to their final position in the KAGRA tunnels.

Once separated in half, it will be easy to transport the type-B chains and their UHV vacuum tanks.

The following strategy has been devised.

2 Sectioning the SAS chain

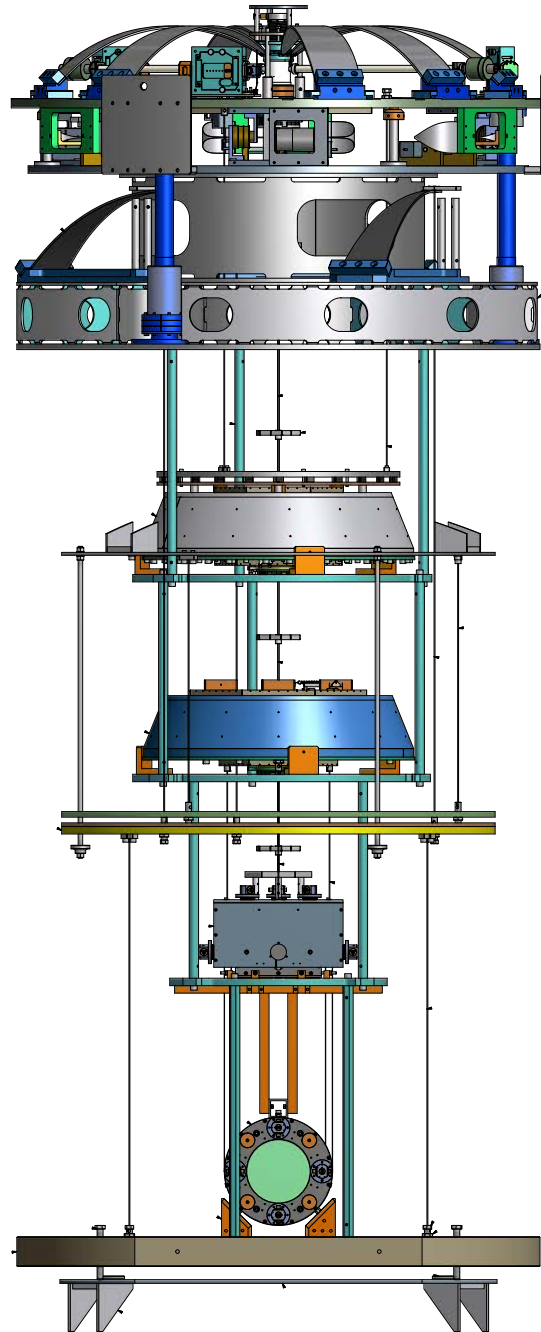

Figure 1: Type B chains and suspended optical bench (vacuum tank not shown)

The type B chains can be seen as composed by two parts, from now on called the seismic attenuator and its payload, and by the suspended optical bench. Note that this division is purely for convenience, the type-B seismic chains are an integrated structure with seismic attenuation and control functions distributed along the entire chain, and there is no physical division between the two arbitrarily separated halves.

As already discussed in the [assembly](#) report, the type B Seismic attenuator and its payload will be integrated in a single unit in a clean booth in the experimental hall. This unit can be lifted via crane from the clean booth and lowered directly into its vacuum tank, from above, with the optical bench already in place in the vacuum tank.

For long distance transport on a truck this unit will be divided in two; the seismic isolator will be sectioned from its payload. Both will be housed in a clean tank. The design of the tanks can be found in section 21 of this [drawing set](#).

The optical bench illustrated in figure 2, the seismic attenuation, illustrated in figure 3 and the payload, figure 4 will travel separately.

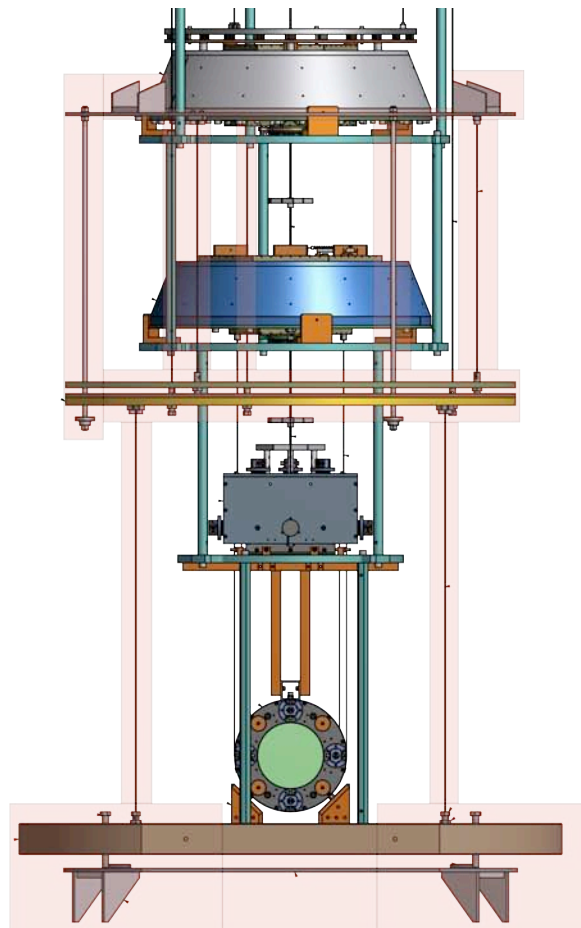

Figure 2: The structure of the optical bench is shaded in pink. The shelves above and below are welded to the inner surface of the tank. The optical bench, which will be fixed to its vacuum tank, will be mounted directly in loco, and then suspended from its springs on the pre-isolator base structure.

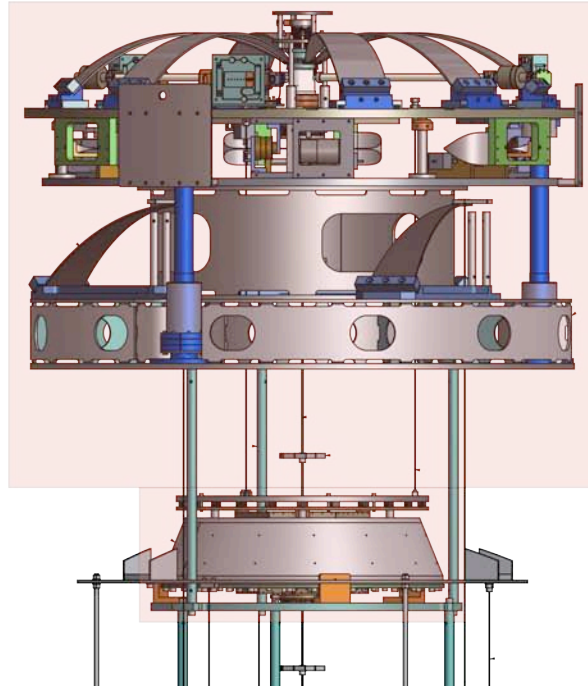

Figure 3: Seismic attenuation, it is composed of the pre-isolator, the standard filter, the Eddy current damper that reduces the mirror low frequency residual motion, and the top part of the safety structure. It fits in a tank 1.7 m high, 1.5 m in diameter.

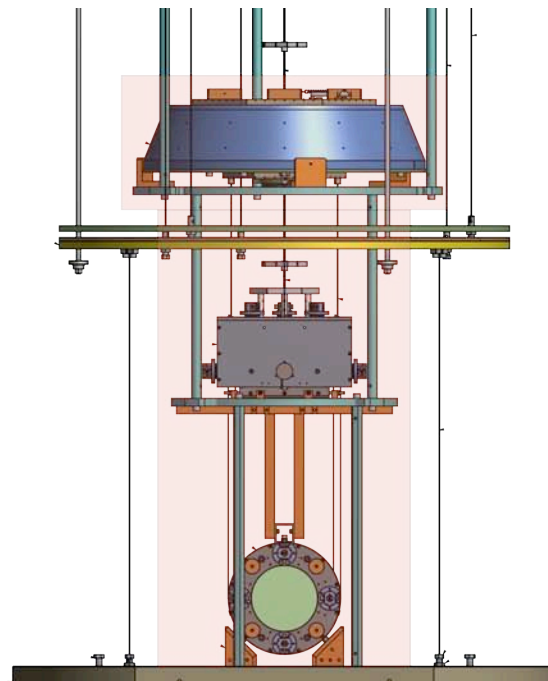

Figure 4: Payload, it is composed by the bottom filter, the intermediate mass and its recoil mass, the mirror and its recoil mass, and the lower section of the safety structure. It fits in a tank 1.7 m high, 0.9 m in diameter.

Only a limited amount of parts have to be removed in preparation for shipment:

- the suspension wire between the standard filter and the bottom filter
- the electrical cabling between the standard filter and the bottom filter
- the three tie rods, between the upper and lower sections of the safety structure
- the three wires supporting the intermediate mass of the suspended optical bench.

The parts to be removed (except the electrical ribbons, which are not shown) are illustrated in figure 5.

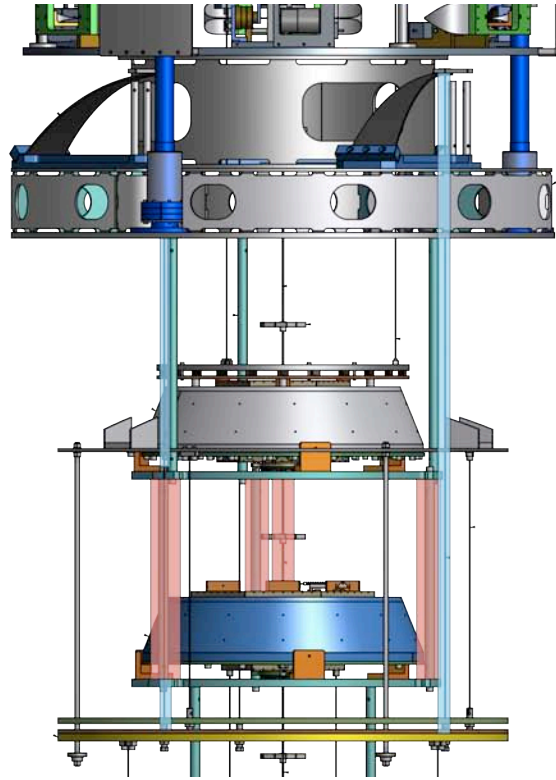

Figure 5: Components to be removed to section the seismic isolation from the payload. Shaded in pink are the mirror suspension wire and the three tie rods connecting the upper and lower section of the earthquake safety structure. Shaded in light blue are the three suspension wires of the optical bench intermediate mass.

The three wires connecting the pre-isolator to the optical bench intermediate mass would be in any case be mounted separately, after the entire seismic attenuation chain is lowered into the vacuum tank.

The electrical cabling for controls, running along the chain, are not shown in figure 5. To disconnect the wiring a crown of male sub-D connectors are mounted on the lateral surface of the bottom filter as illustrated in figure 6.

The disconnected cables, with their female connectors will be unclipped from the hexagonal cable rack on the octagonal shelf on top of the bottom filter, unclipped from the cabling spider along the

suspension wire, rolled up, and temporarily secured to the hexagonal cable rack on the bottom of the standard filter.

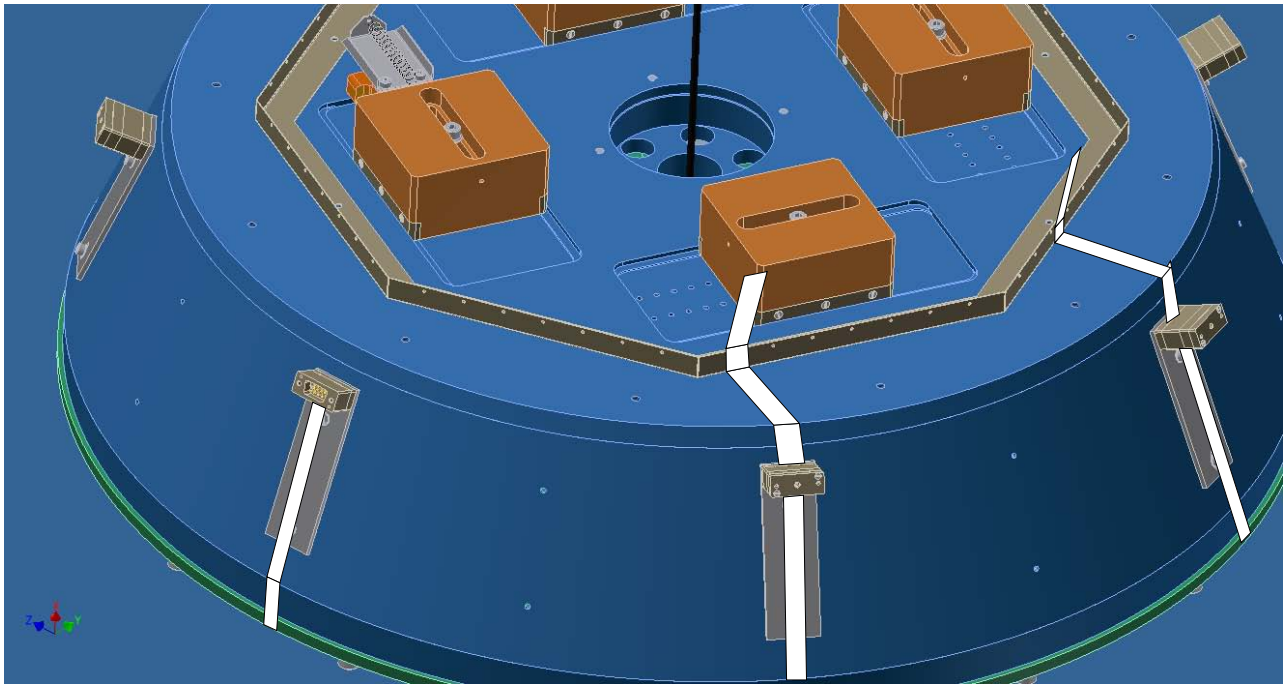

Figure 6: Crown of [connectors](#) mounted on the bottom filter. The ribbon cables coming from below end in the male connectors bolted to the lateral surface of the bottom filter. The cables coming from above (one shown as removed) are clipped to the octagonal shelf, and then fold up towards the cabling spider above. To separate the two halves of the chain, the cables are disconnected, unclipped from the shelf, and from the spider, and rolled up all the way to the standard filter above.

2.1 Immobilizing all components for shipment

Even after being disconnected, the seismic isolator and the payload cannot safely travel unless many, small precautions are taken to immobilize all moving parts and keep them from bouncing around and being damaged.

Special travel containers, very rigid and almost water tight, will keep the sections UHV clean and safe during transport.

At the end of the transport the two sections will be re-united in a clean booth and rapidly inserted in the vacuum chamber.

The rest of the report discusses the details of immobilization of all moving parts, and the travel containers.

2.2 The Top transport tank

The transport tank for upper half chain, shown in figure 7, weighs 395 kg, is about 1.5 m in diameter and 1.7 m in height.

The gross weight of the isolation chain (including only Type B pre-isolator and standard filter) is 1448 kg. The center of mass is 1.0 m from ground.

The tank has bottom ears for bolting to a transport pallet. A layer of soft expanded polystyrene is inserted between the tank and the pallet to reduce high frequency vibrations.

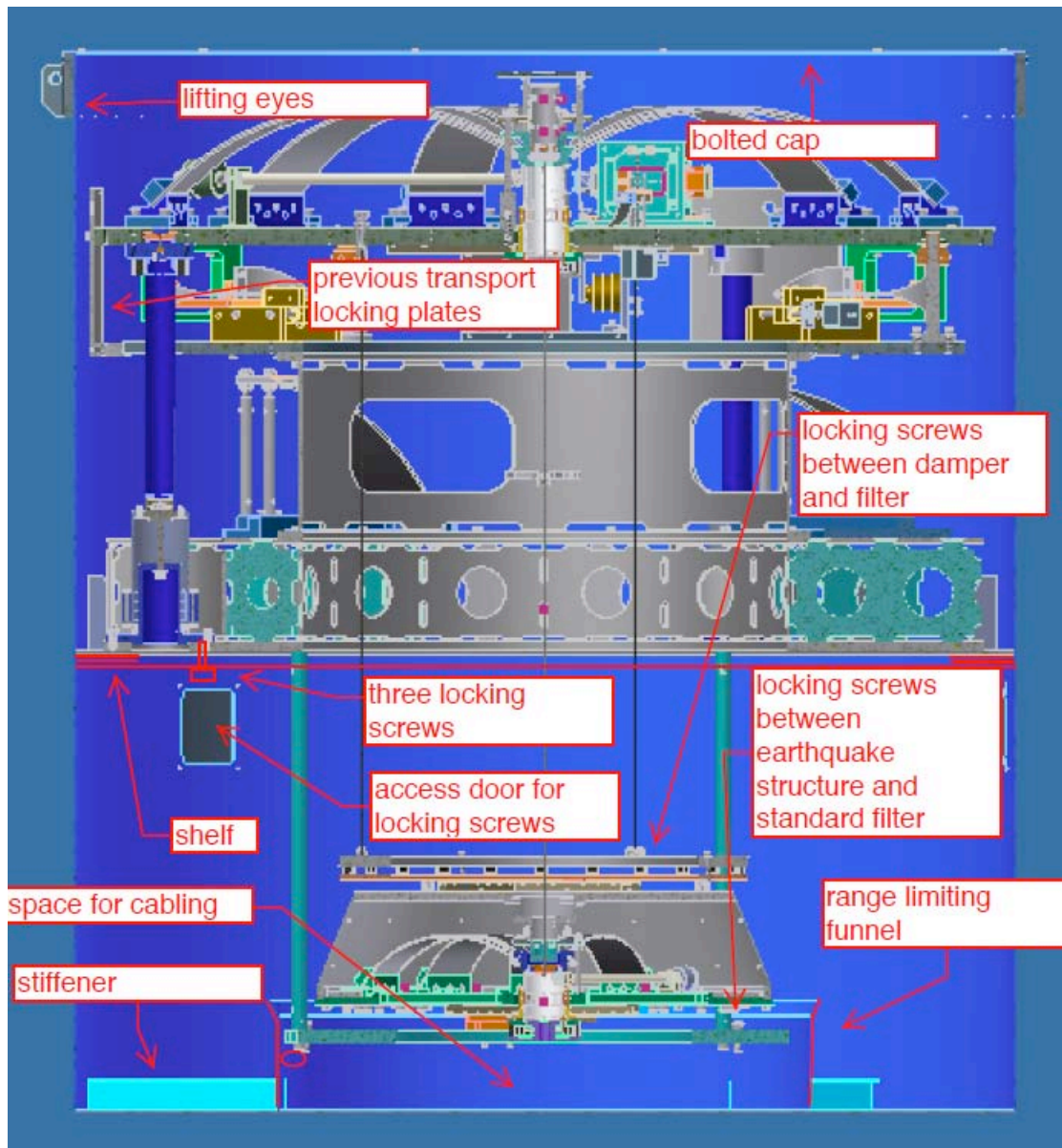

Figure 7: Transport tank loaded with the type-B seismic isolator.

The transport tank is a stainless steel tank provided with a circular shelf to support the pre-isolator base structure. The shelf is held by stiffeners that also act as insertion guides. At the bottom of the tank, a 900 mm diameter cup immobilizes the transversal motion of the safety structure and the standard filter. The shelf is provided with three slots designed to lock the pre-isolator base with three M12 bolts. Three access windows are foreseen below the shelf, in correspondence with the slots, to insert or remove the three bolts.

A strong stiffener ring is welded at the rim of the tank, with three lifting eyes. The stiffener is also provided with numerous threaded holes to secure the cap, which is a simple metal disk with a soft rubber gasket.

The cup at the bottom has a slanted rim to ease insertion of the safety structure, and is tall enough to leave 10 cm of empty space for the coils of cables temporarily secured below the standard filter, and protected by a thin sheet metal transport plate as shown in figure 15.5.

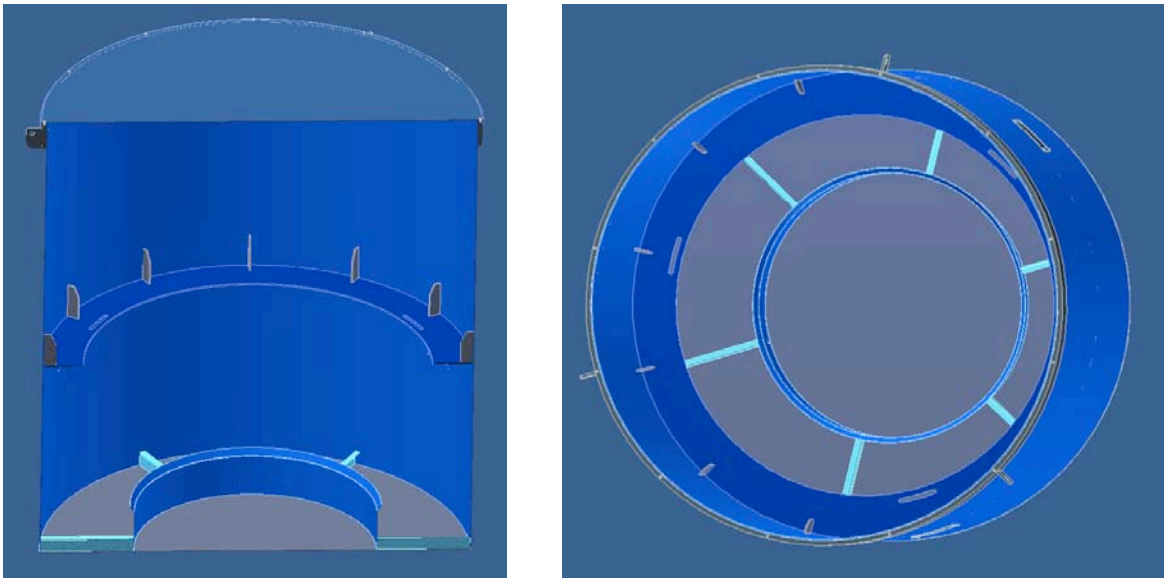

Figure 8: Cutout and top view of the tank.

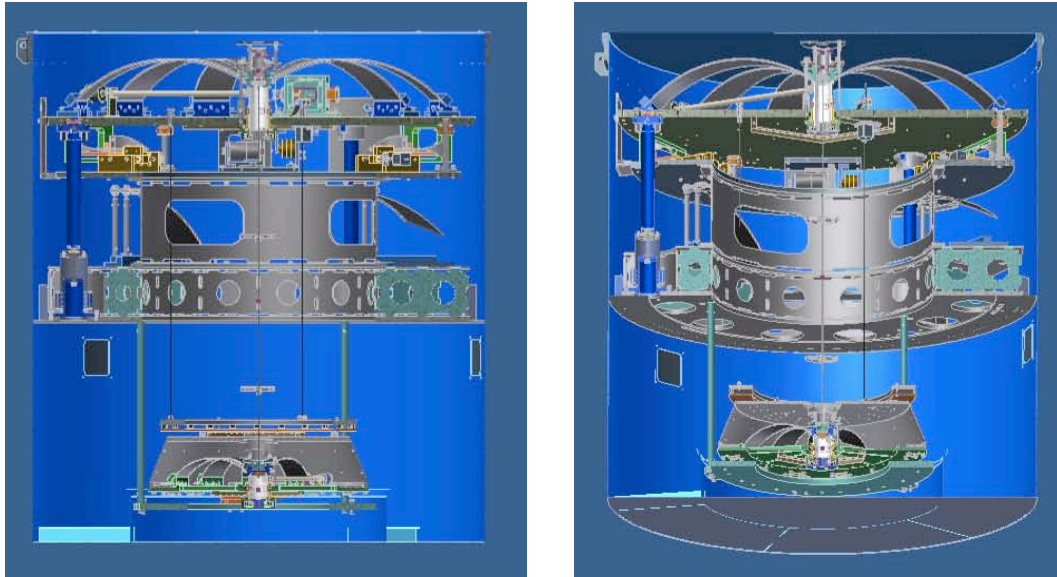

Figure 9: Side views of the loaded tank.

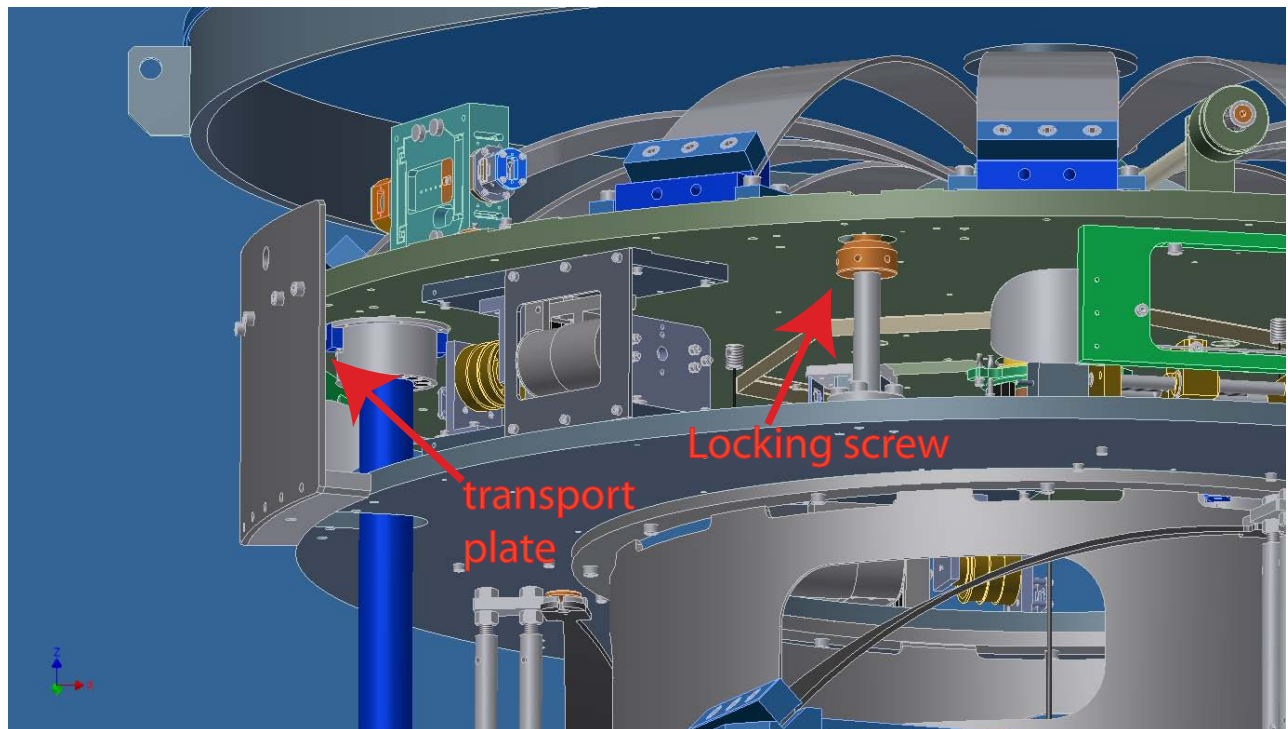

Figure 10: The orange locking screw-head are engaged to lock the horizontal movement of the IP. Then the transport plates are mounted to lock the Inverted pendulum to the base structure of the pre-isolator.

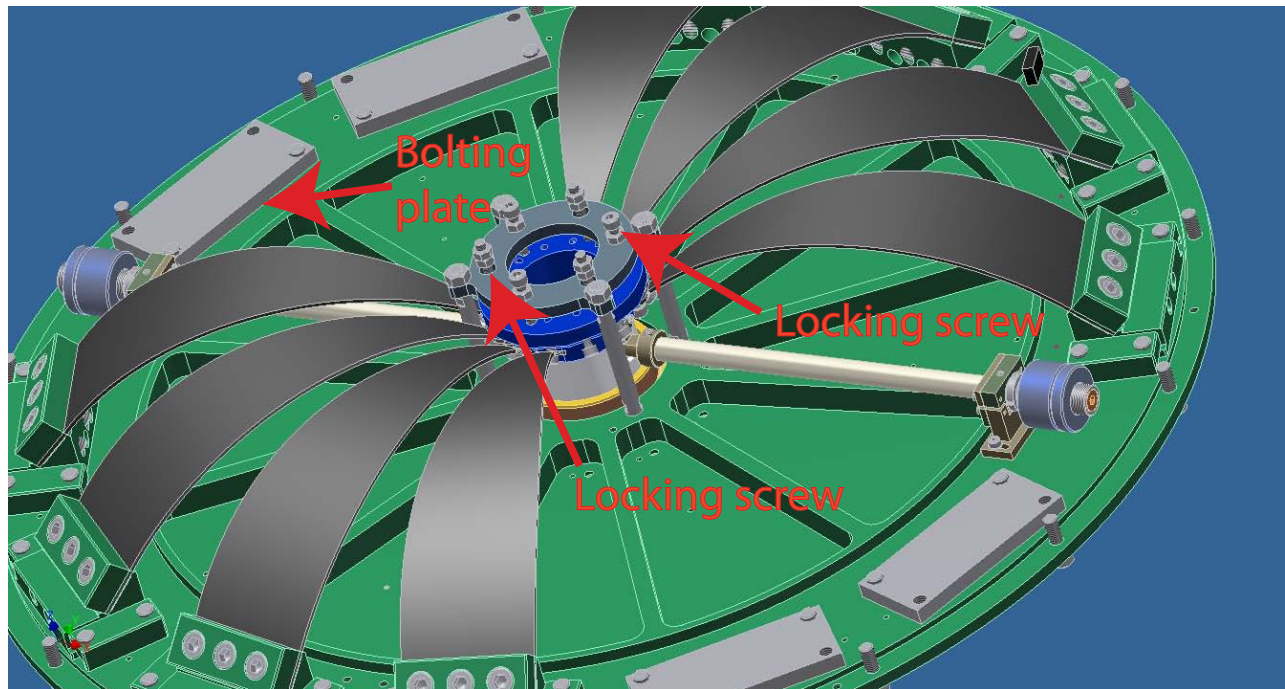

Figure 11: The three range limiter screws and nuts are engaged to lock the vertical movement of the GAS springs. Bolting plates have been added in the unused slots of suspension blades. Two of the threaded holes in the plates will be used to bolt the filter to its safety structure as illustrated in figure 12.

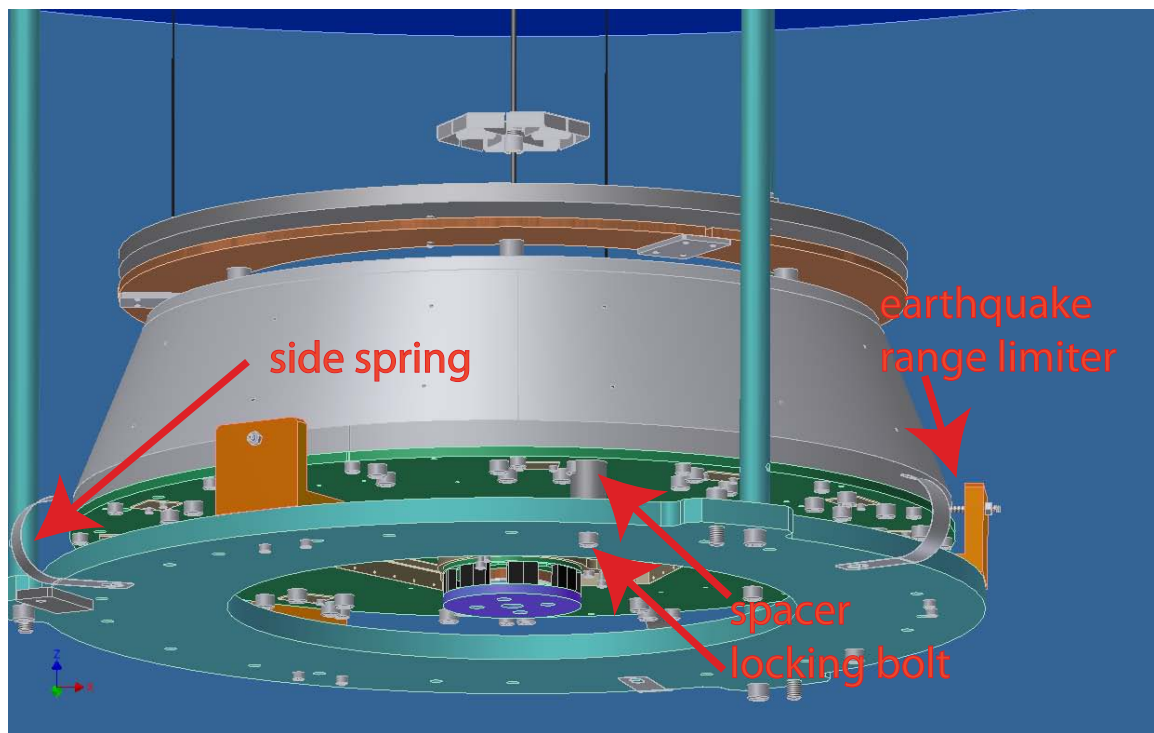

Figure12: The spacers and bolts lock the standard filter to its safety structure. The Earthquake range limiters can be engaged as well. The side spring mounted for transport hold the safety structure firmly inside the transport can.

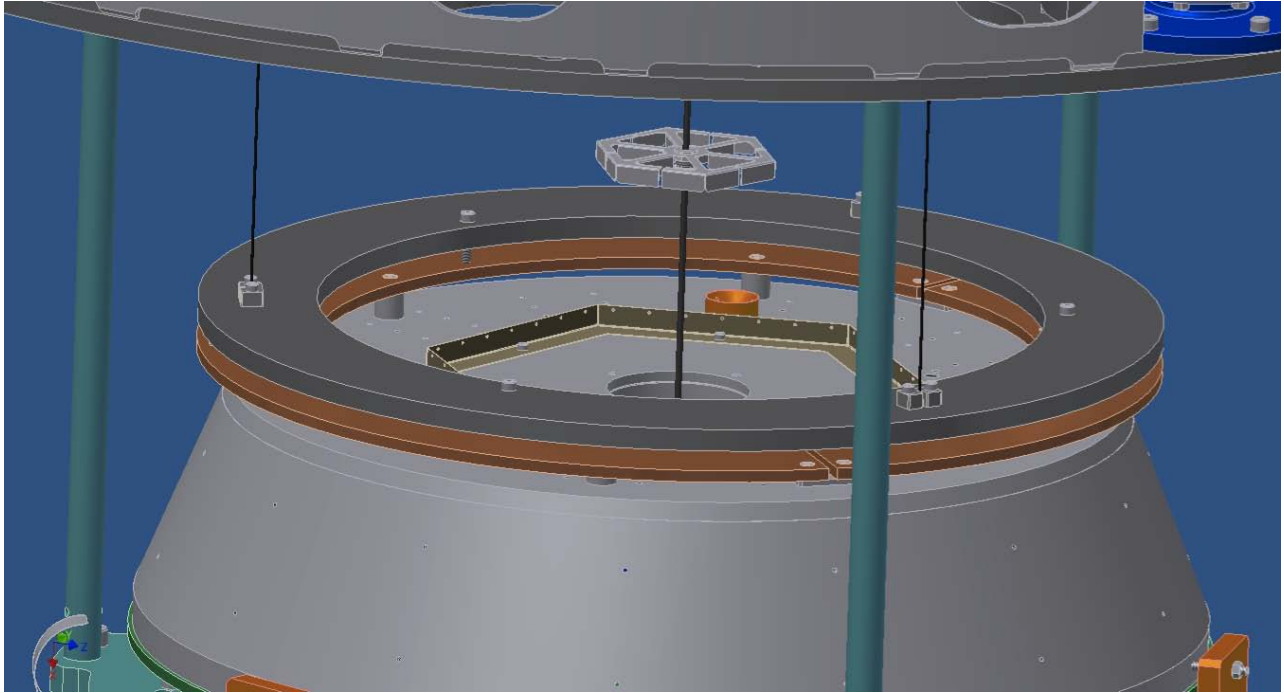

Figure13: Three temporary bolts lock the magnetic damper ring to its copper ring on the top of the standard filter.

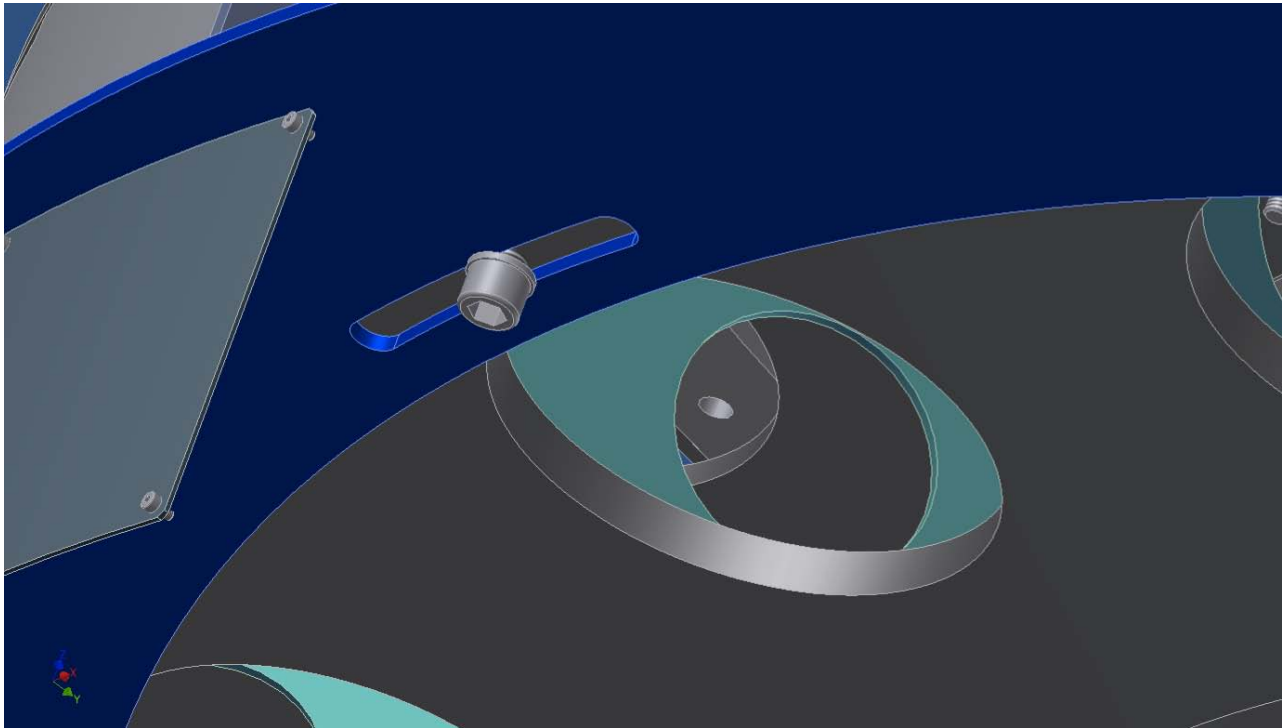

Figure 14: Three bolts secure the base of the pre-isolator to the transport tank shelf. They are accessed through the access door, shown in grey on the left, while the tank's wall has been made transparent to allow view of the bolt.

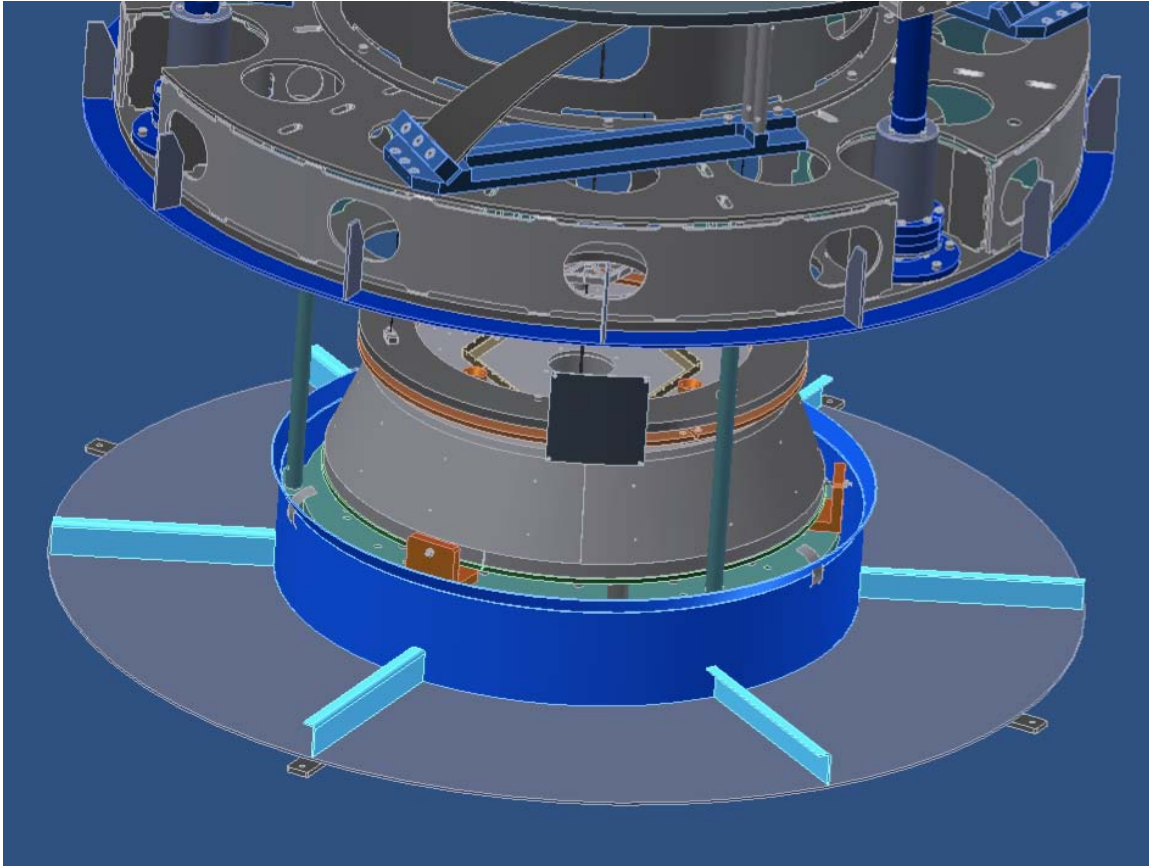

Figure 15: The safety structure fits inside the cup at the bottom of the tank, where the side springs shown in figure 12 impede the lateral oscillation of the standard filter against the safety structure.

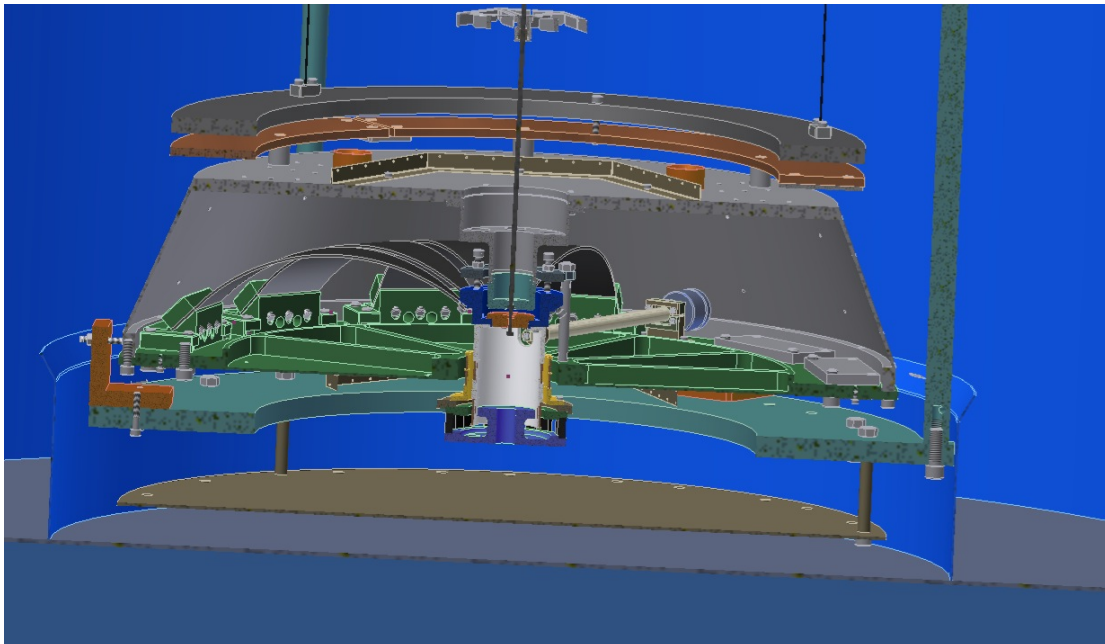

Figure 15.5 temporary cable tray supporting the coiled ribbons during transport.

2.3 The Bottom transport tank

The transport tank for the payload is smaller, but otherwise similar to the large tank.

The transport tank for the payload, shown in figure 16, it weights 99 kg, is about 0.9 m in diameter and 1.7 m in height.

The gross weight of the payload (including its safety structure) is 362 kg. The center of mass is 1.12 m from ground.

The tank has bottom ears for bolting to a transport pallet. A layer of soft expanded polystyrene is inserted between the tank and the pallet to reduce high frequency vibrations.



Figure 16: The transport tank for the payload is much smaller. The bottom plate of the tank is provided with bolting lips to attach the tank to a transport pallet. The payload locked into its safety structure is bolted from above onto a circular shelf.

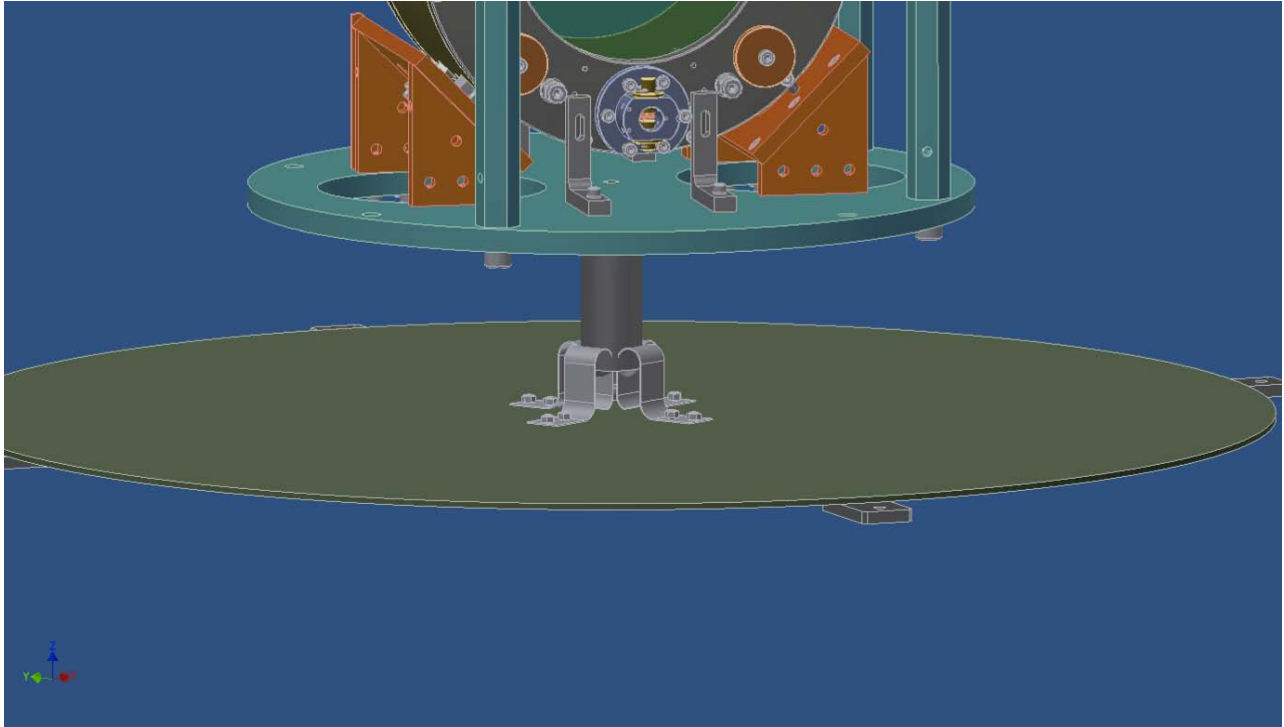

Figure 17: A temporary stud is screwed under the bottom of the payload safety structure. When the payload is inserted into its transport tank, the stud slips between 4 springs impeding its transversal motion.

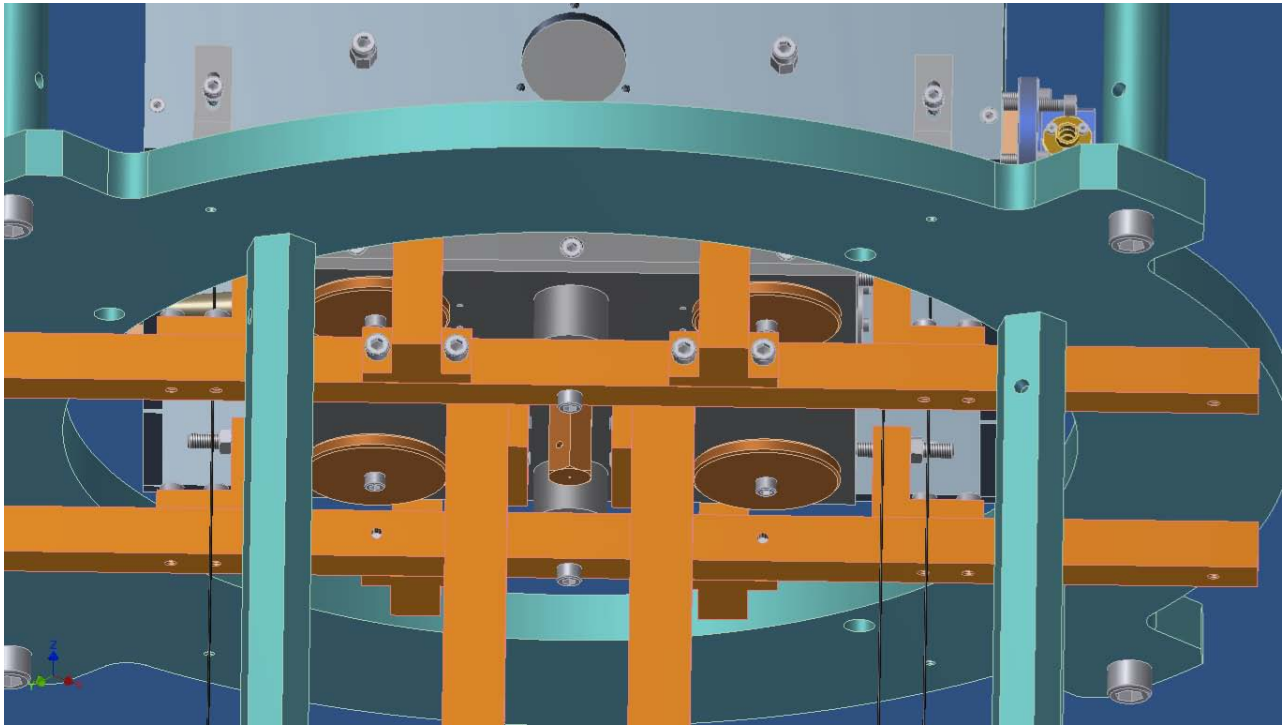

Figure18: Two bolts and spacers lock the intermediate mass to its safety structure.

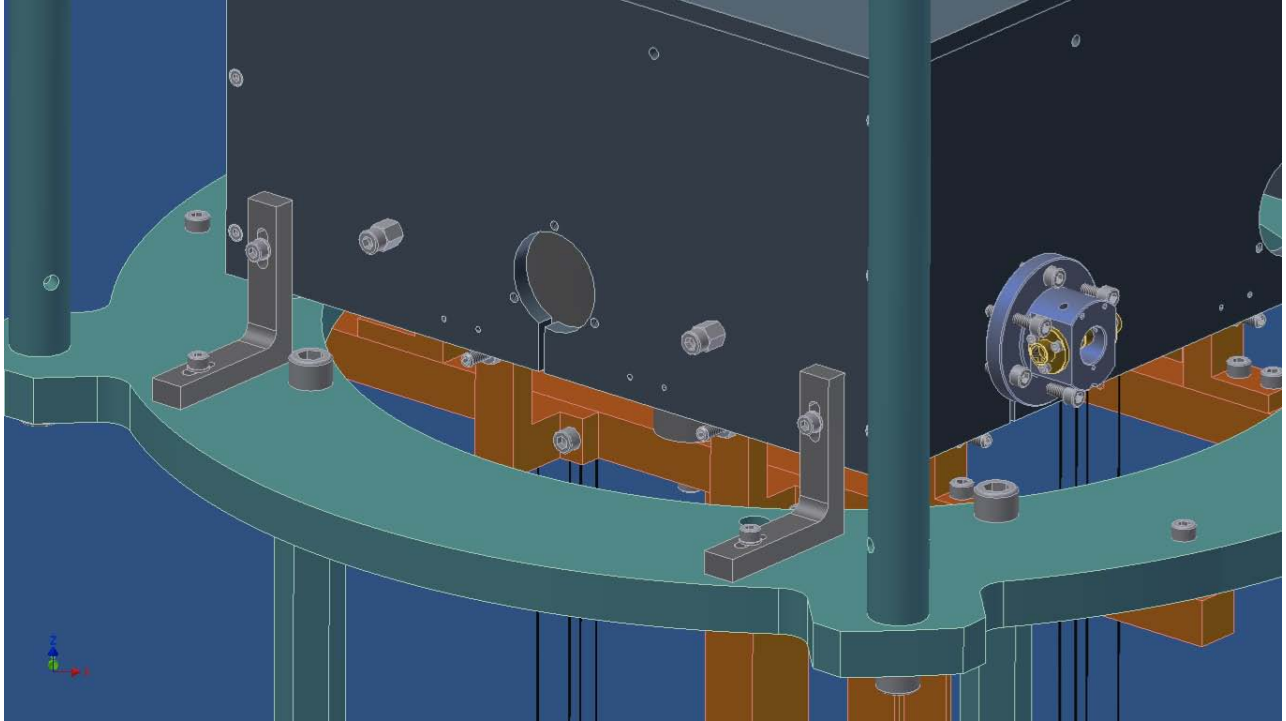

Figure19: Four brackets lock the transversal movement of the intermediate recoil mass. Note: slots are foreseen in the brackets because the intermediate mass and its recoil mass are first positioned and weakly interlocked by tightening their mutual motion range limiting screws. The brackets are tightened down last to provided added rigidity.

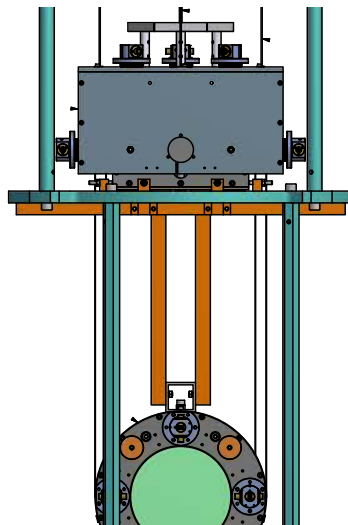

Figure 20: Two bars tie the intermediate mass to the mirror recoil mass.

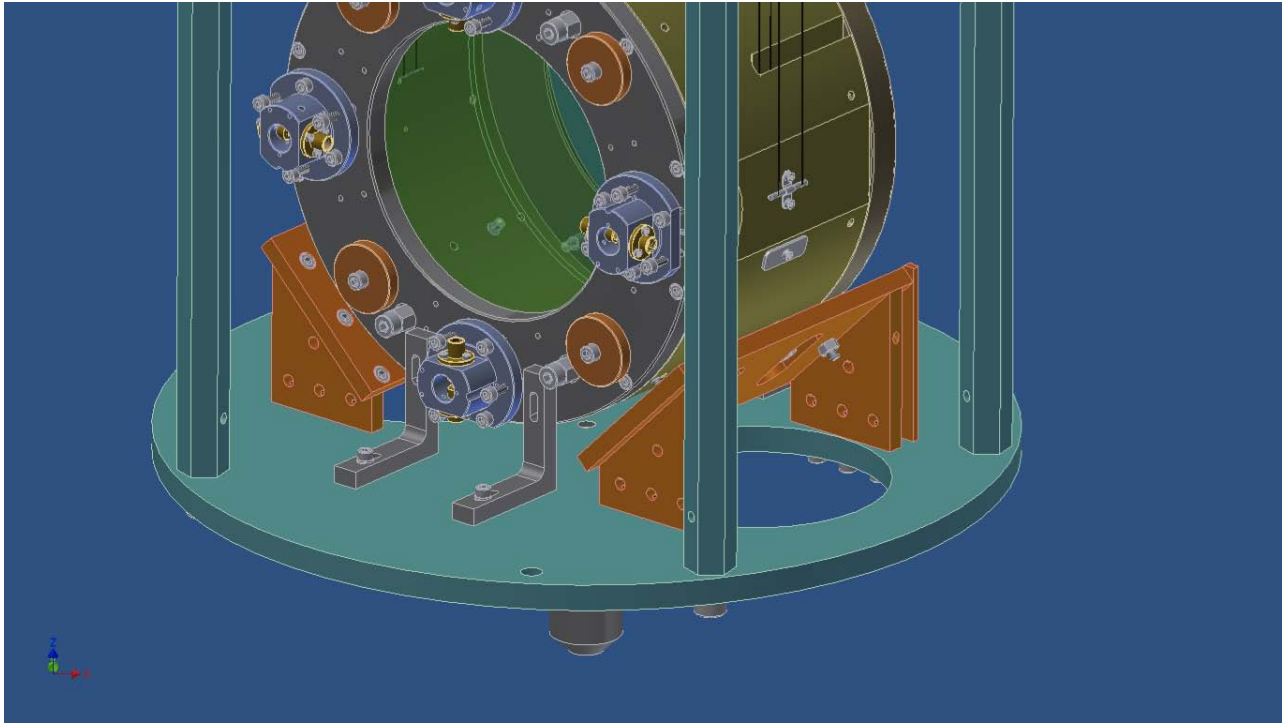

Figure 21: The mirror is locked inside its recoil mass by tightening its range limiting screws, after inserting Nylon spacers. Four brackets lock the longitudinal motion of the mirror recoil mass, they only sit against it, because the recoil mass is already solidly locked to the intermediate mass in the vertical direction.

3 The UHV vacuum tanks.

The UHV vacuum tanks are delivered with protection flanges on the large ports and blind conflat flanges in all smaller ports. The top and bottom parts, as well as the three SAS support bellows can be assembled and leak tested. The assembled tanks are rigid enough that they can be rotated 90° and safely travel on flat bed trucks. They can be lifted from the truck bed by the experimental hall crane, and raised back to their vertical position. Because they are sealed, the UHV cleanliness inside the tank is automatically preserved.

The external structures supporting the SAS chains would be disassembled and travel in a separate crate, independent from the tank.

4 Disassembly and Reassembly.

The SAS towers can be assembled and tested well in advance. The best storage place is to keep the full chains stored inside their own vacuum tank. The SAS tower can then be rapidly sectioned, the SAS chains stored in their transport tanks, and shipped.

Once the three components have been moved from the assembly and testing site, or from the storage site, to the experimental hall the tanks can be positioned to their final position. The two halves of the SAS chains can be reconnected, freed from the hard transport locks, and re-tested in the local assembly clean room. Then the reconstructed chains are lifted and lowered in the tank.

The entire operation should take less than a working day. If only one set of tanks is built, the longest delay may well be the time to send the empty tanks back to the storage place to be refilled.

This procedure will greatly accelerate the commissioning time of KAGRA.

5 Moving the fully assembled and tuned Type-B SAS towers along the KAGRA tunnel.

There is an interesting option that can be considered.

The type-B SAS towers are designed for the beam splitter and recycler mirrors. Their SAS chains are designed for assembly in a clean room inside the experimental hall, then lifted with the crane, and lowered in its vacuum chamber. This operation is adequate for its use in b-KAGRA.

There is an option that can be considered for initial KAGRA. In i-KAGRA there will have no power recycling and no signal recycling, therefore only two of the three power recycler mirrors will be necessary to allow the beam to follow the dog-leg path leading to the beam splitter. Therefore four Type-B towers would be initially unused.

The type-B towers are designed to carry the same mirror size as the four main mirrors of i-KAGRA. Therefore there would be a great economical and manpower advantage, as well as an acceleration of the commissioning, if the four available Type-B towers could be used to suspend the i-KAGRA main mirrors.

5.1 Air cushion transport

The main problem is that there is no crane to assemble the Type-B towers in the working locations of the ITM and ETM of i-KAGRA.

There is a second problem that the few m of connection tunnel between the experimental halls and the i-KAGRA ITM and ETM locations are 4 m tall, 70 cm lower than the Type-B towers (figure 22). If these few meters of tunnel length could be made 80 cm taller, the following scenario could be enacted.

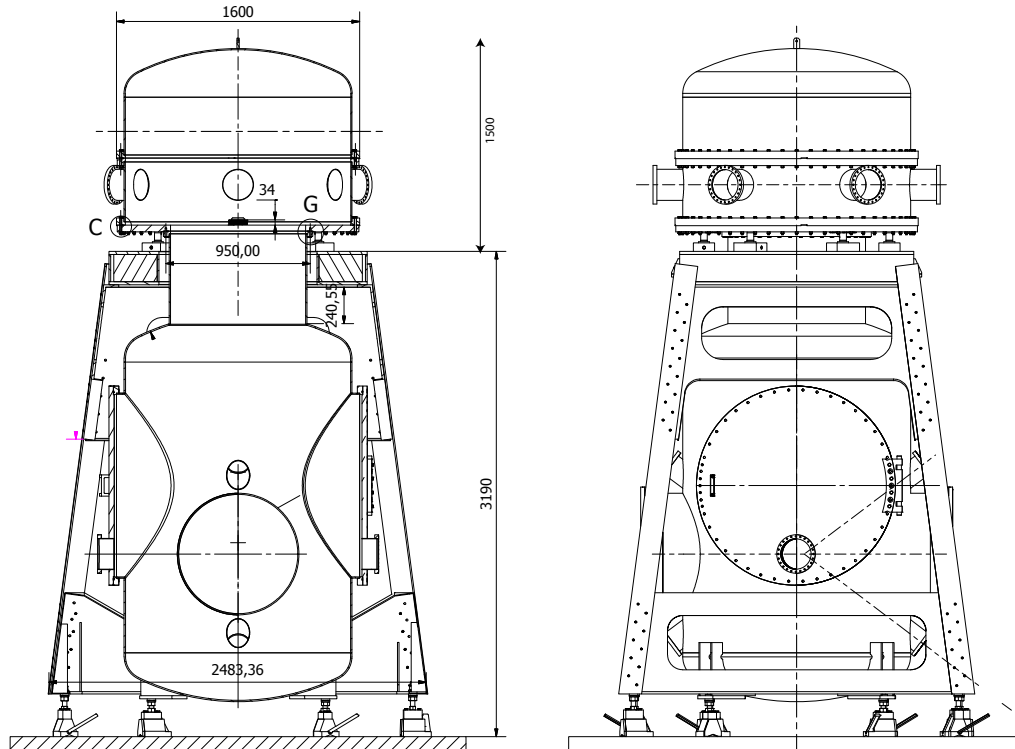

Figure 22: Dimensions of the Type-B SAS towers.

The Type-B SAS towers can be fully assembled in the central or in the end experimental halls, and then transported, fully functioning, already loaded with their mirrors, to their working location. This can be safely and precisely done with aircushion plates, an operation that is commonly done industrially, as can be seen in:

http://www.youtube.com/watch?v=PEwDu8ka_RI and <http://www.aerofilmsystems.com/products>.

At CERN the 2,000 or 3,000 tons of the AU2 experiment were precisely moved in and out of the beam-line by aircushion, propelled by a modified bicycle.

A much simple system can be implemented at i-KAGRA. A steel plate 2.5x2.5 m can be fitted with a 10 cm wide, bolted rim structure, containing a rubberized cloth skirt, as illustrated in figure 23.

The entire Type-B SAS structure, can be mounted on the plate, and magnetically clamped (it is already provided with magnetic clamps for relocation).

Air is blown inside the rubberized cloth skirt circling the plate, thus generating a soft seal to the ground. Properly located holes in the cloth pressurize the air below the plate and lift it. Less than 0.1 atmosphere pressure, provided by a blower, is sufficient to lift the tower. Then the fully functioning SAS tower can be pushed by hand.

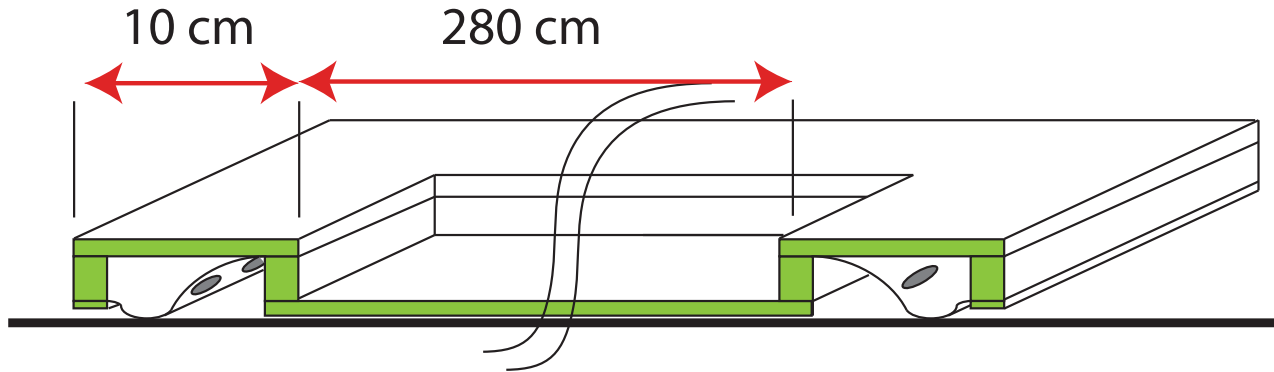

Figure 23: Schematized aircushion plate to move type-B SAS towers at KAGRA.

The Type-B SAS tower, complete of its vacuum tank and external structure, can then be drifted on the floor to the desired location, provided that the floor is sufficiently flat. Steps can be passed with a “Panama” approach of shimmed plates.

6 In situ cleaning of the mirrors.

The transport locking mechanisms described above are convenient in case that mirror cleaning is necessary.

The mirror is locked inside its recoil mass, and the recoil mass to the safety structure. Then a lint-free cloth can be applied on the mirror surface, first contact sprayed onto it on several layers. After drying, the cloth is stripped and the mirror released.