



# Type-B seismic attenuation chains and vacuum tanks

Riccardo DeSalvo  
for Seismic group  
JGW-G1200835



# Type-B performance

- Type-B performance exceeds noise requirements for beam splitters and recycler mirror
- Type-B performance exceeds residual motion requirements for easy lock acquisition
- See Sekiguchi's thesis [P1200770](#)
- Note: OSEM Sensor/Actuator's parameters still to be optimized, but easily within requirement parameters
- See K. Yamamoto [T1100812](#)



# Type-B design concepts and implementation strategies

- Much more complex system than assumed by most collaborators
- Mechanical complexity:
- To make operations simple
- To allow simple and rapid installation
- To allow for mobility



# General concepts

- 1500 mm diameter tank
- Easy access to optics and optical bench from one port
- 2000 mm tanks have non accessible areas
- >2000 mm allows walk in but is not affordable
- Dirtytness issue

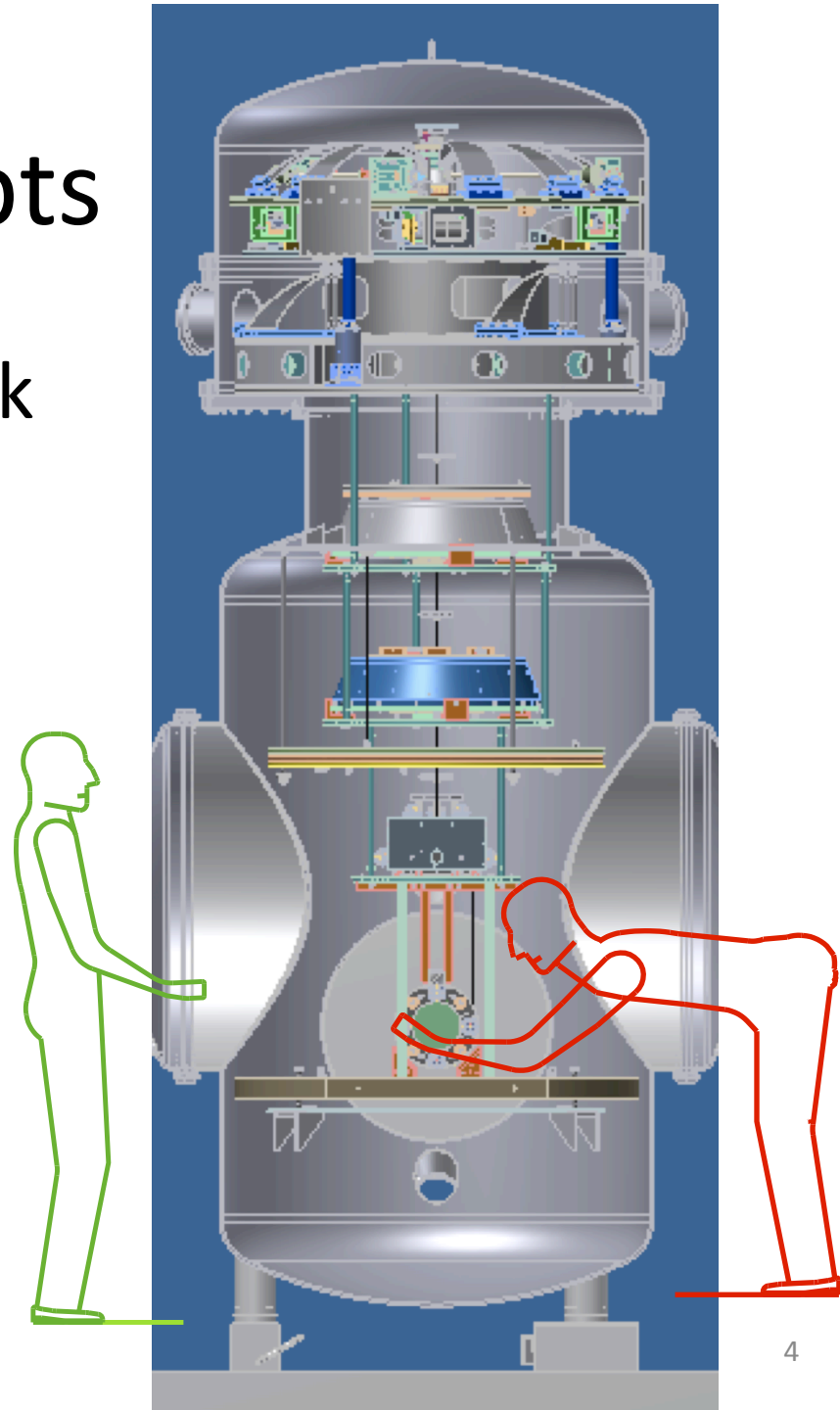



# Cleanliness issues

- Inject clean air from top port during access
- **Persons work from outside**
- **Shoe dirt stays out and sweating is continuously swept away**

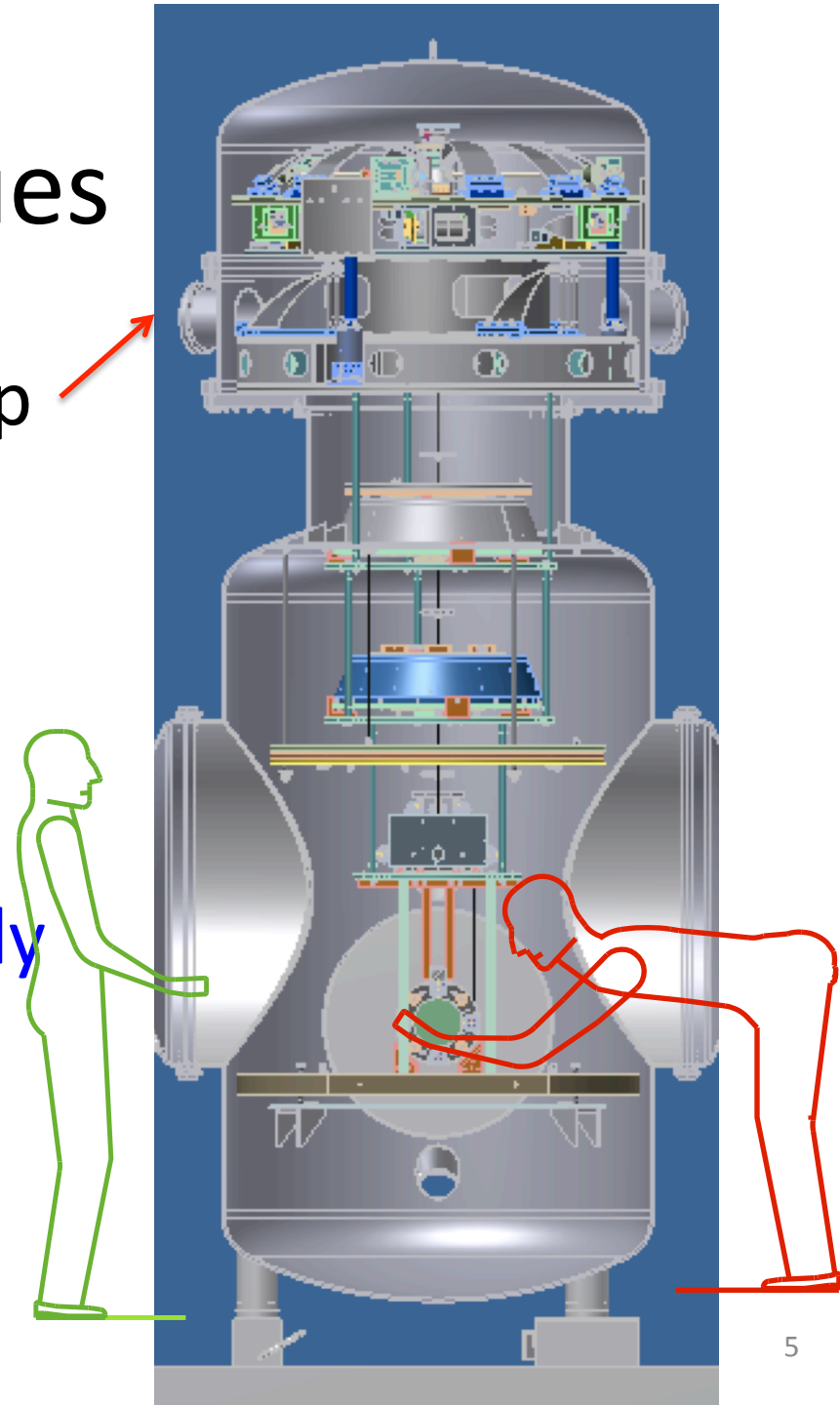



# The four components of type-B

- External structure



- Vacuum tank

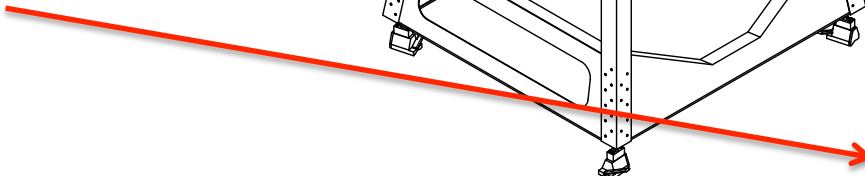

- Attenuation chain

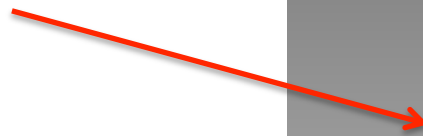

- Optical bench

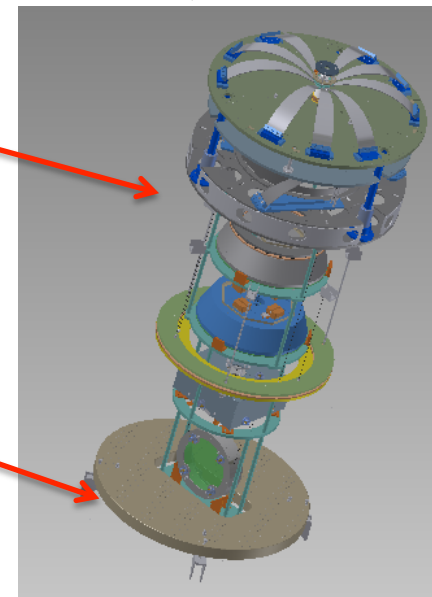
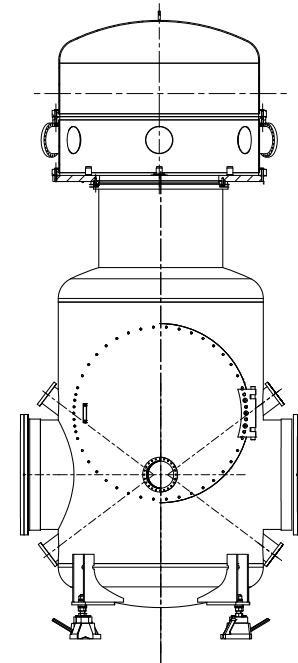
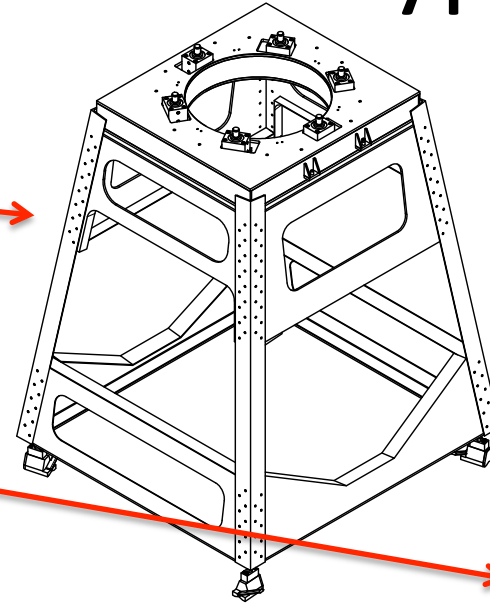
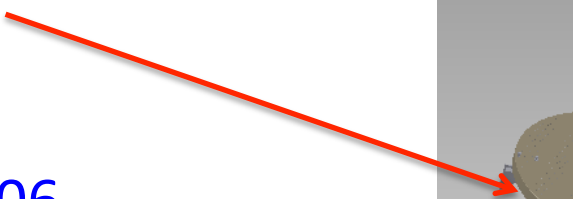



# External structure

- Welded and bolted painted steel structure
- Built for rigidity
- Mechanically Independent from noisy vacuum tank
- Supports the attenuation chain platform
- Supports the optical levers
- Magnetic feet to satisfy relocation requirements
- Also see [T1100638](#)

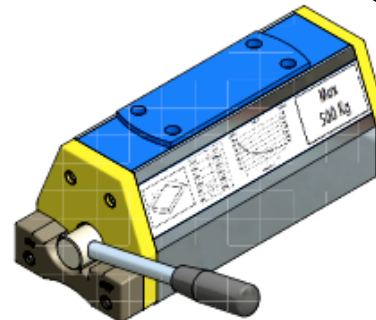
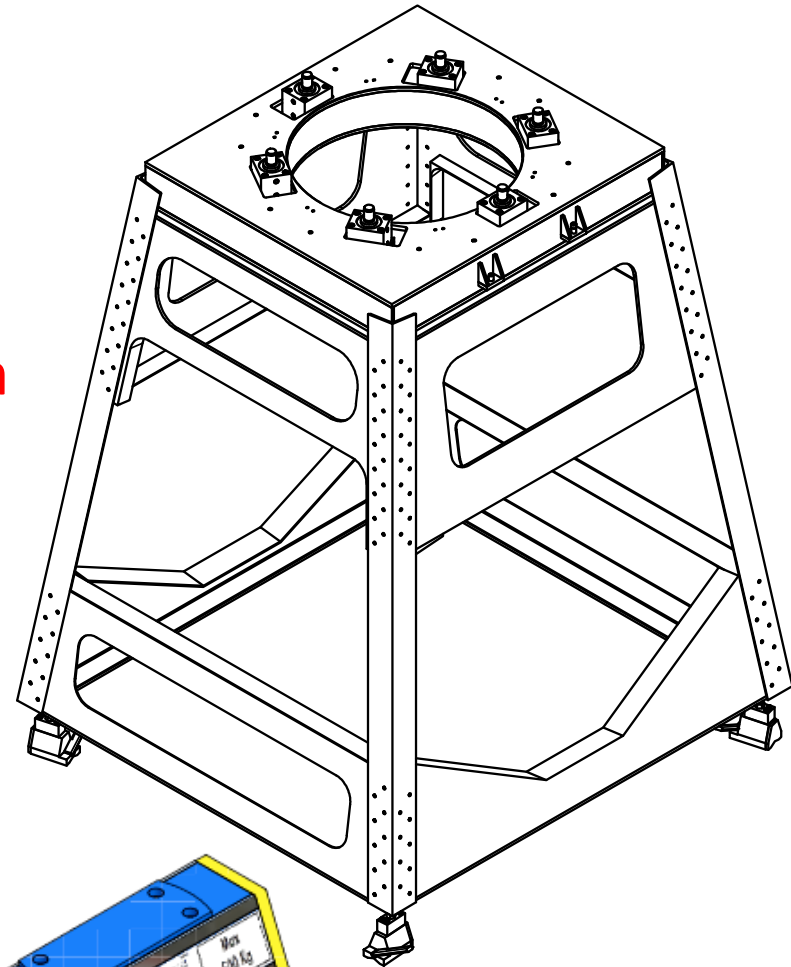



# Vacuum tank

- Top chamber contains pre-isolator, same as type-A
- **1200 mm diameter access ports**
- View ports for optical levers
- **800 mm diameter beam ports**
- Magnetic feet to satisfy relocation requirements

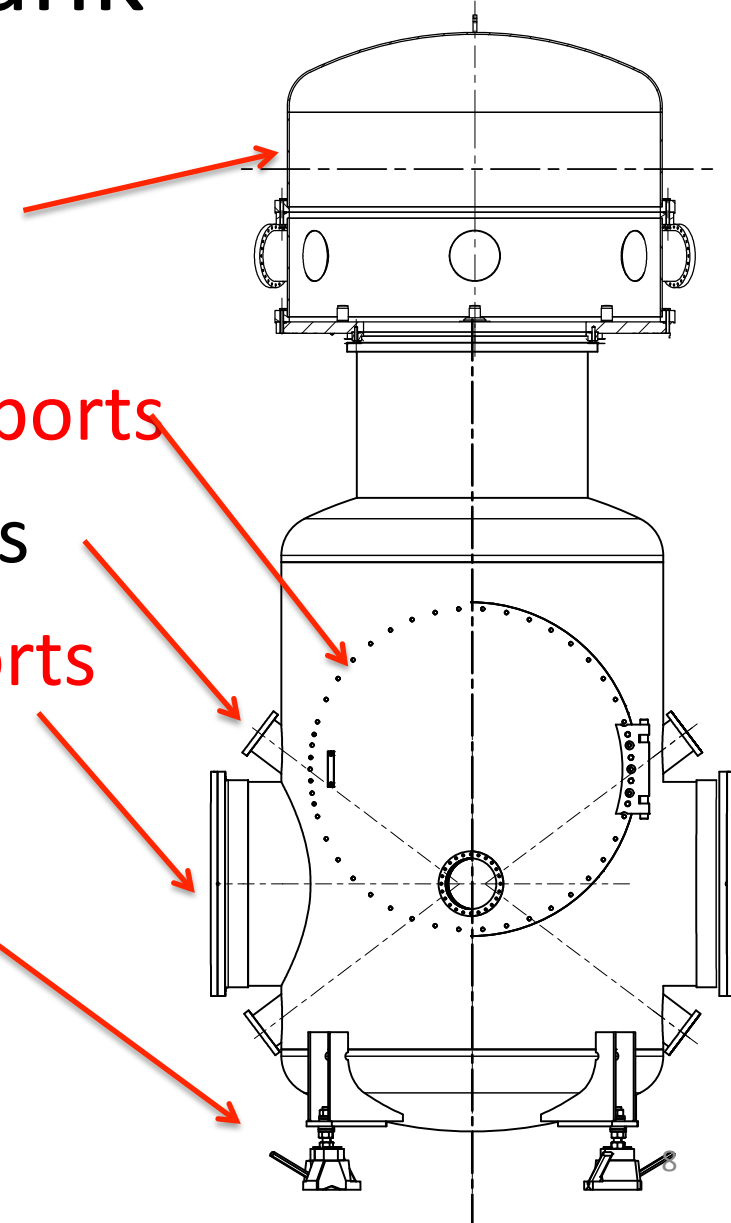

Design drawings [D1200819](#)





# Attenuation chain

- Pre attenuator = inverted pendulum + top filter
- Standard filter and Eddy current damper
- Bottom filter
- Intermediate mass and its recoil mass
- Mirror and its recoil mass

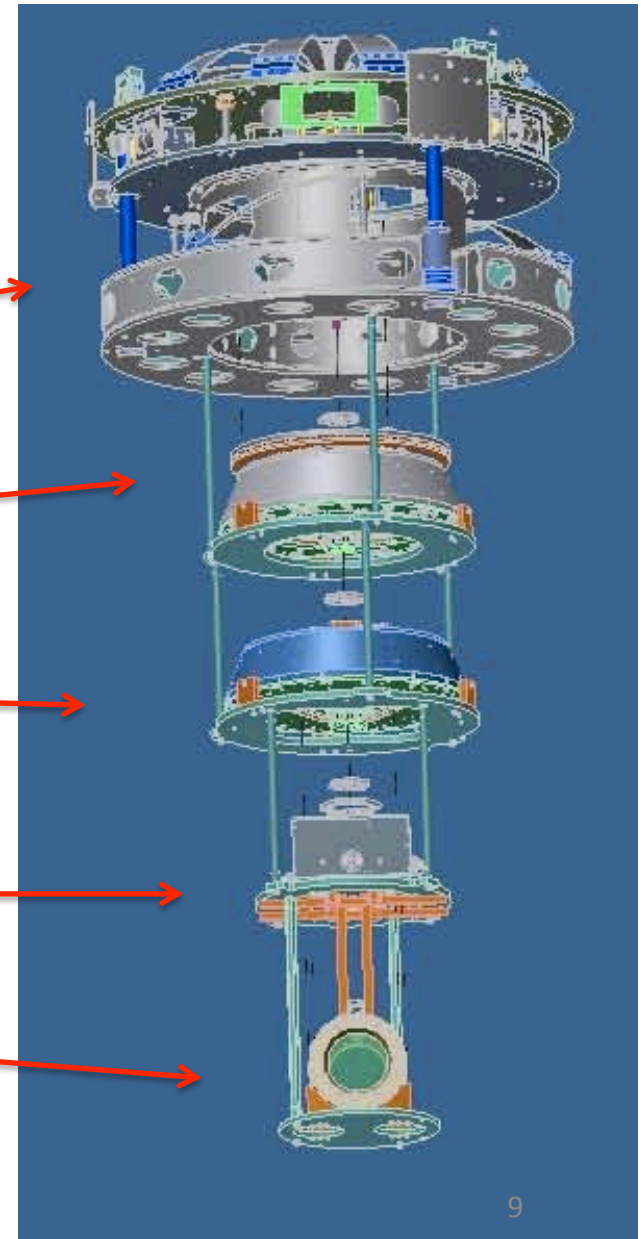

Design drawings [T1100450](#)

3/2/12

and [D1200818](#)



# Optical bench

- Suspended on three springs on Pre-attenuator structure
- Double pendulum
- Eddy current damper
- Aluminum honeycomb optical bench

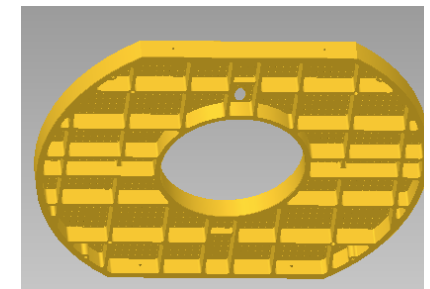
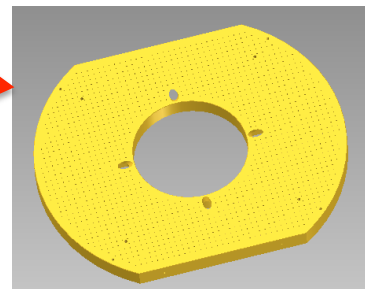
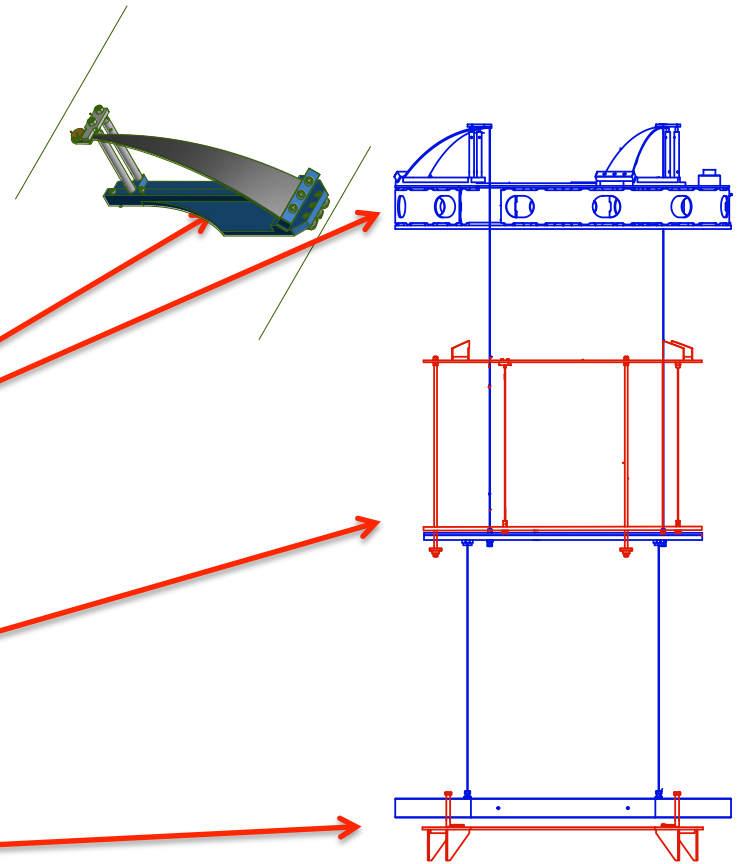



# Pre-attenuator Functions:

- Attenuation at 0.1 Hz
- **top filter** + **Inverted pendulum**
- Fine transversal positioning, static and dynamic (tidal tracking)
- **Static yaw control of chain**
- Suspends chain
- **Suspends damper**
- Suspends optical bench

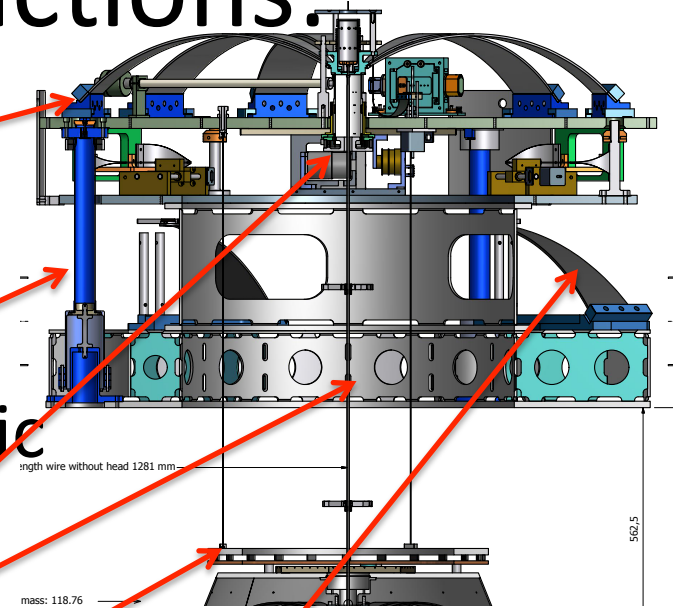



# Standard filter: functions

- Standard GAS filter attenuation
- Eddy current damping of chain resonances
- Natural reduction of r.m.s. residual motion of mirror

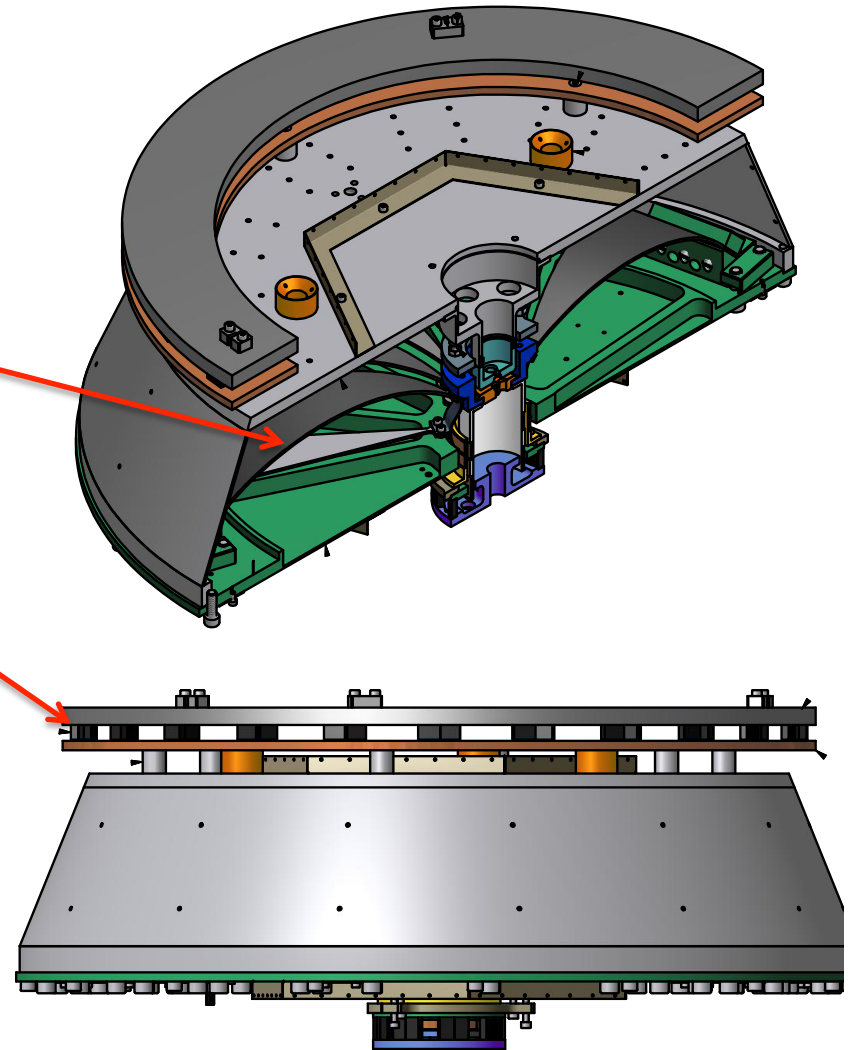

Production status [T1200804](#)



# Bottom filter: functions

- Standard GAS filter attenuation
- Vertical control of intermediate mass
- Tip-tilt control of intermediate recoil mass (three wire marionetta)
- Static yaw control of intermediate mass with respect to its recoil mass

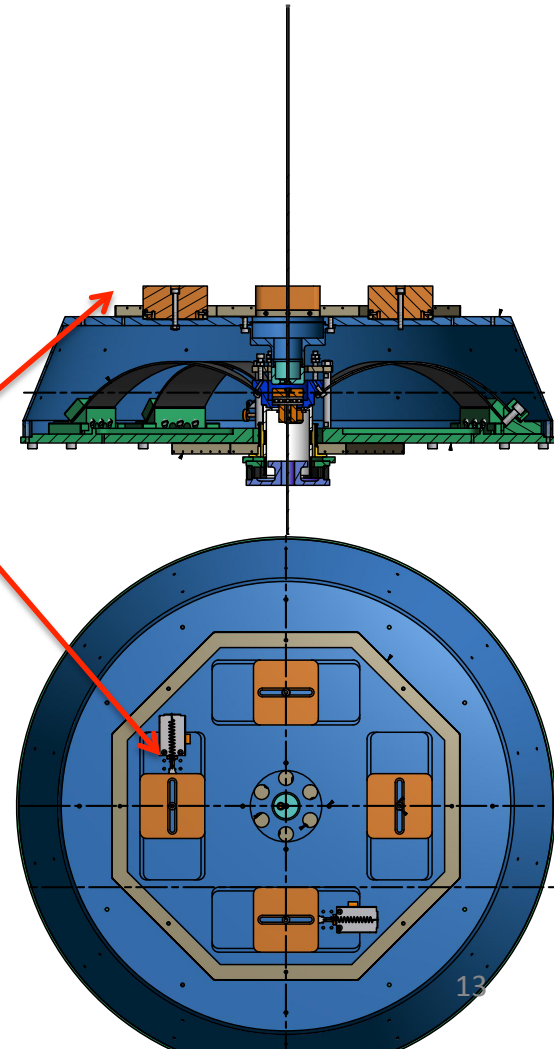
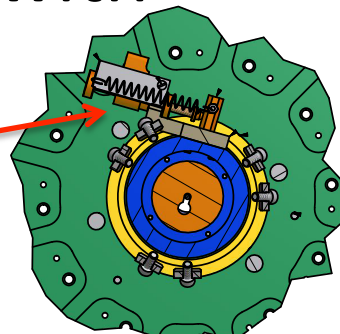



# Intermediate mass: functions

- Wire suspensions of mirror and its recoil mass
- Static controls of mirror pitch and roll (length + yaw from preattenuator)
- Dynamic 6 d.o.f. control of mirror (OSEMs)
- Locks/ earthquake stops to intermediate recoil mass

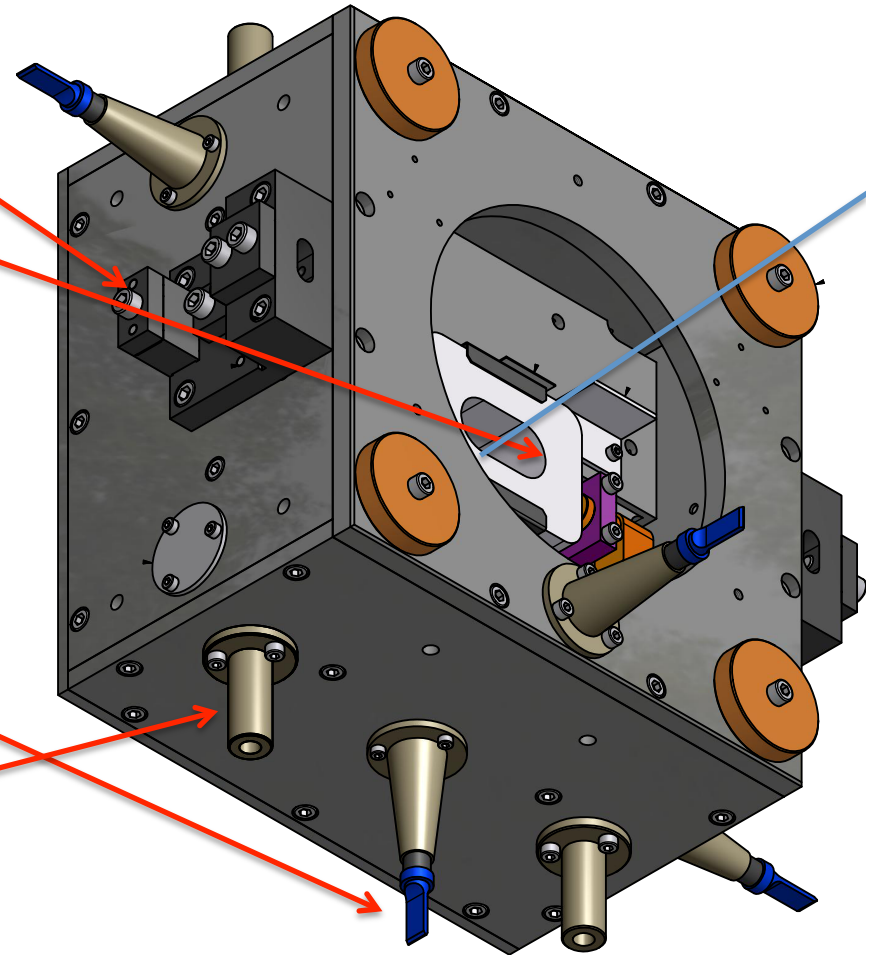



# Intermediate recoil mass functions

- Dynamic 6 d.o.f. control of intermediate mass

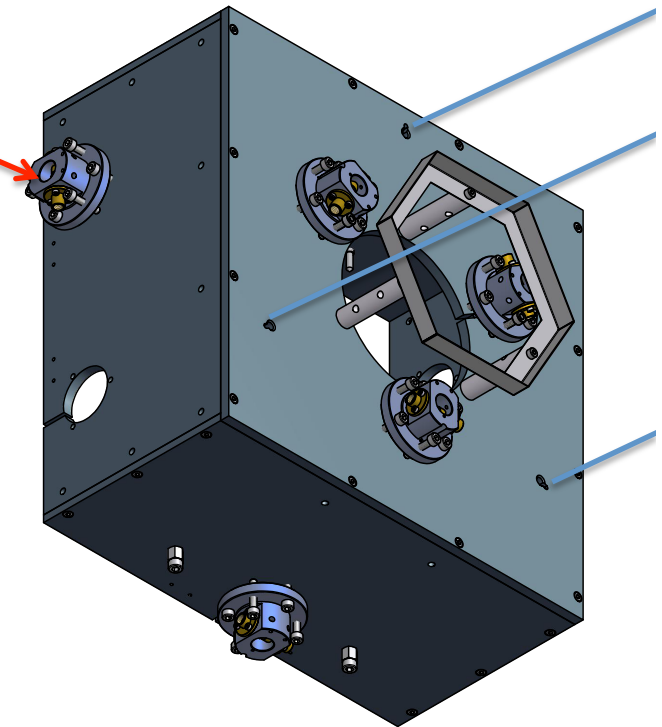



# Mirror recoil mass functions

- Fine dynamic controls of interferometer length and mirror pitch and yaw (OSEMs)
- Eddy current damping of relative motion (whip from intermediate mass)
- Main scattered light baffle

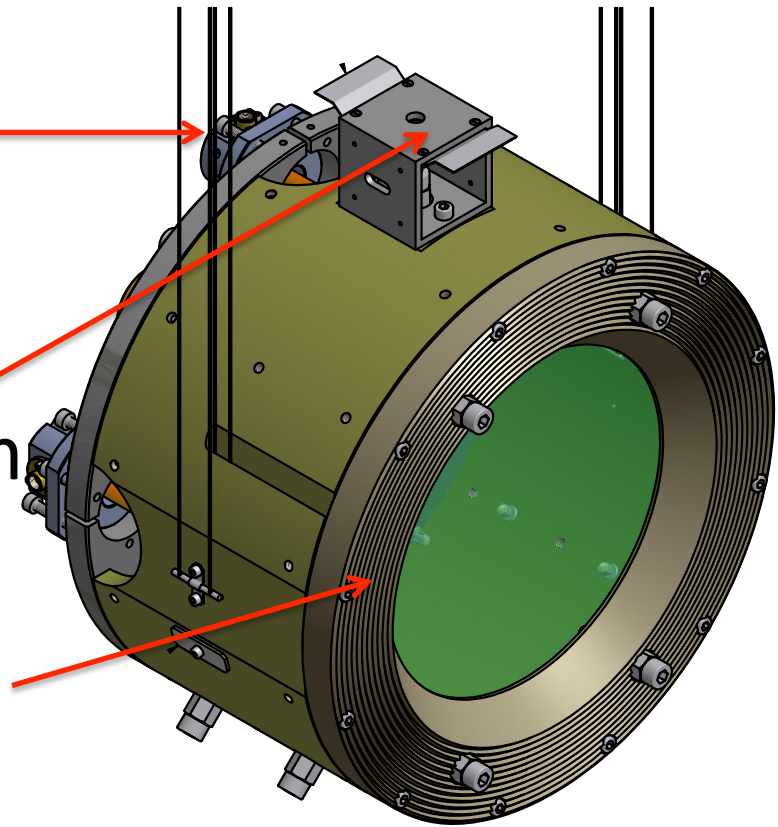





# Earthquake safety structure: functions

- Mounts below pre-attenuator frame
- Provides earthquake stops
- Immobilizes attenuation chain during transport
- Very important, allows pre-implementation and transport

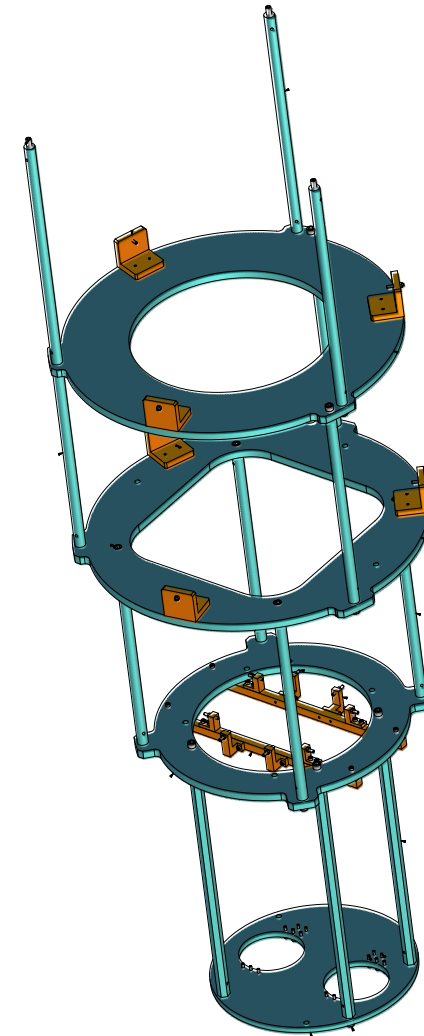



# Assembly procedures: mirror

- Mirror glue tool
- Position OSEM flags
- Position wire breakers

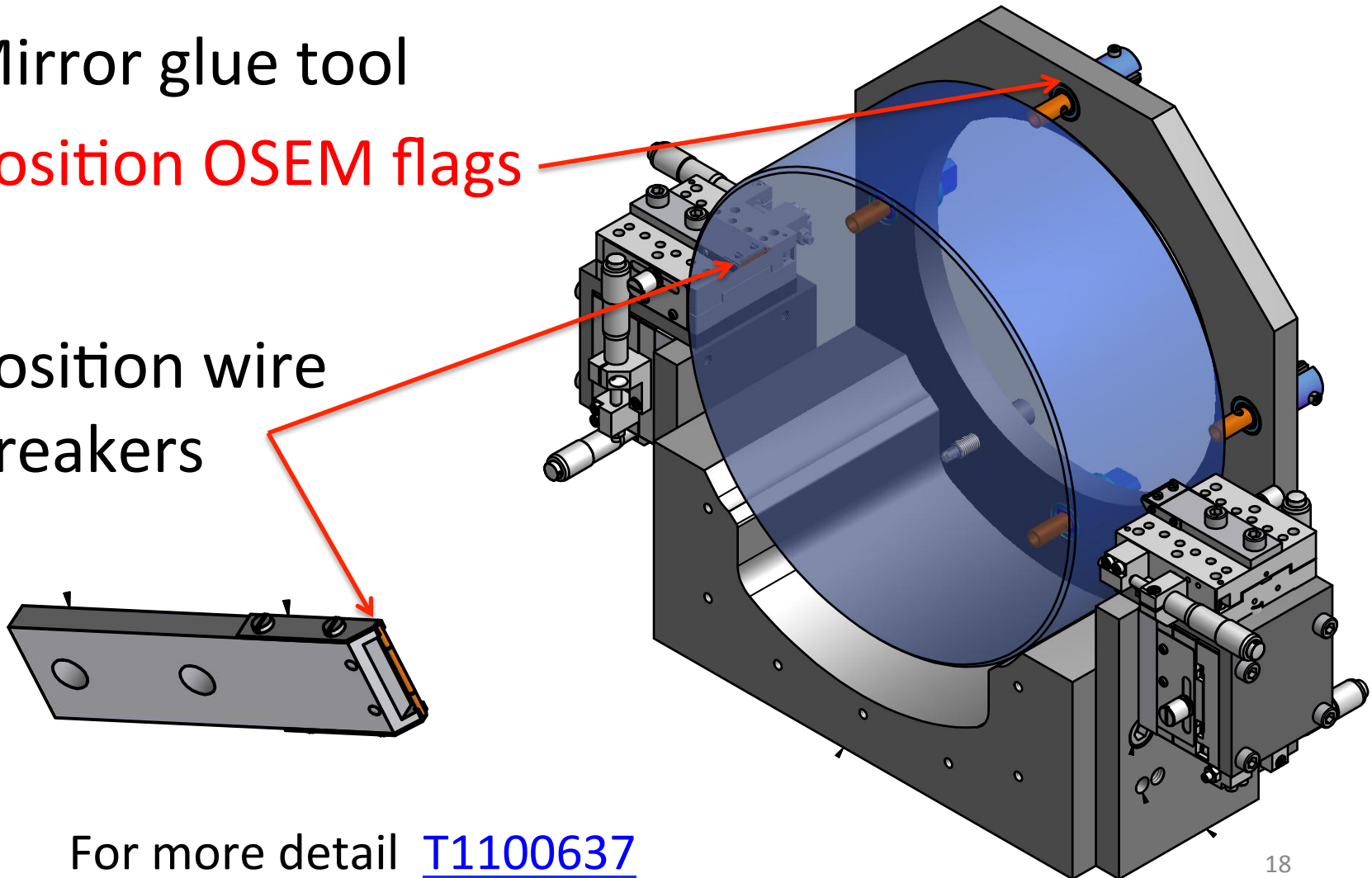



# Assembly procedure: suspending mirror and recoil mass

- The mirror is suspended on wires and balanced by means of 4 winches
- Then the mirror stand is removed, the recoil mass slides in position and is similarly suspended
- The wire clamps are locked

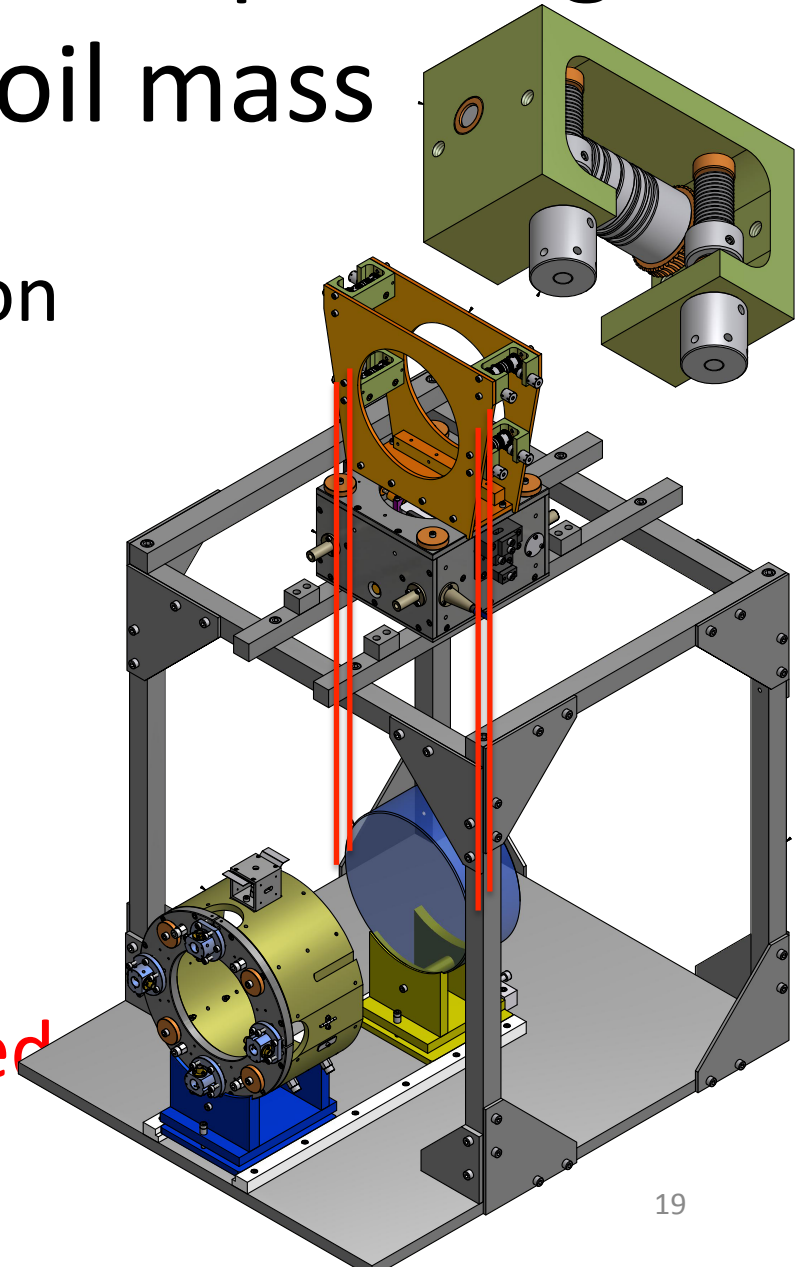



# Transporting mirror and intermediate mass

- The intermediate recoil mass is mounted around the intermediate mass and secured by means of screws
- The recoil mass is secured to the intermediate mass by means of temporary transport bars
- The mirror is locked inside its recoil mass by means of radial and axial set screws

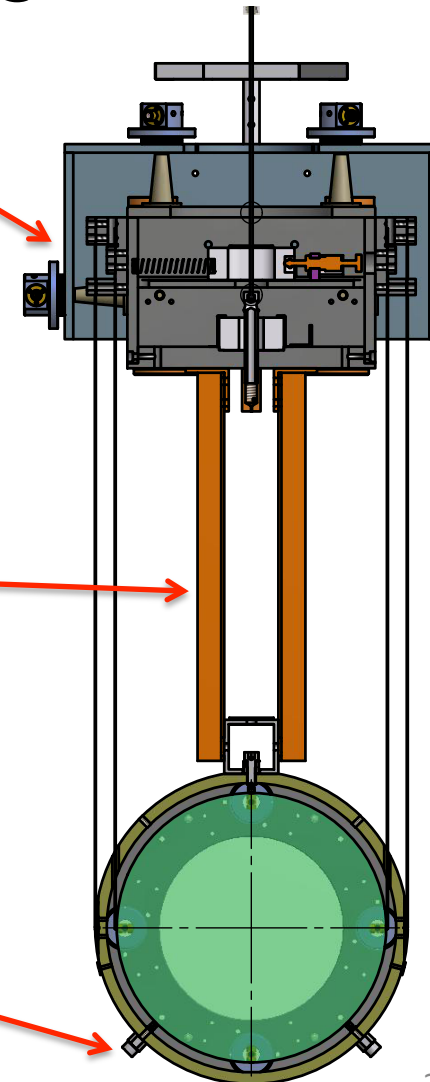



# Assembly procedure: the filters

- A clean room stand is used to mount and cable the chain in its earthquake safety structure
- The mirror and recoil mass are lowered in place first
- The filters are added one by one and cabling is implemented
- The filters are secured to the safety structure
- The chain is ready to be lifted out of the stand and for transport

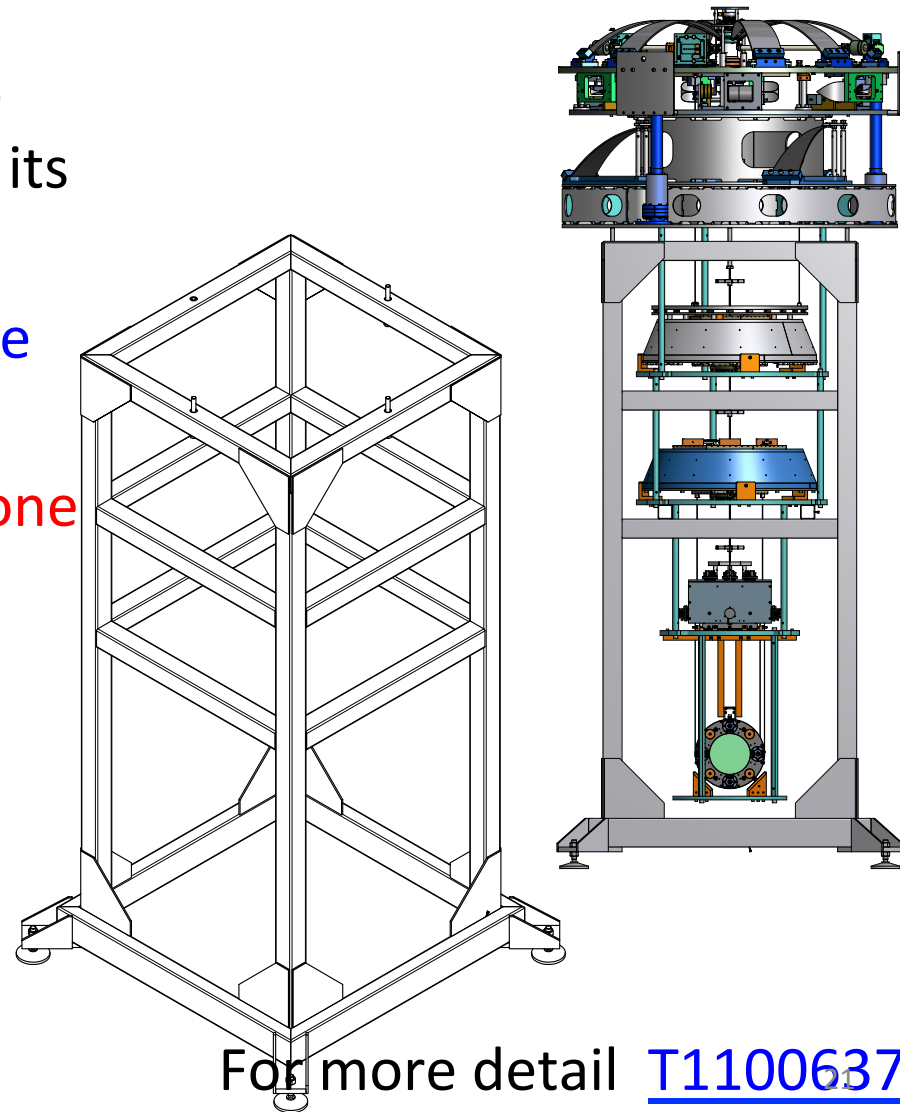

For more detail [T1100637](#)



# Moving the attenuator in the vacuum tank

- After assembly the attenuator can be lifted from the stand and lowered in a vacuum tank

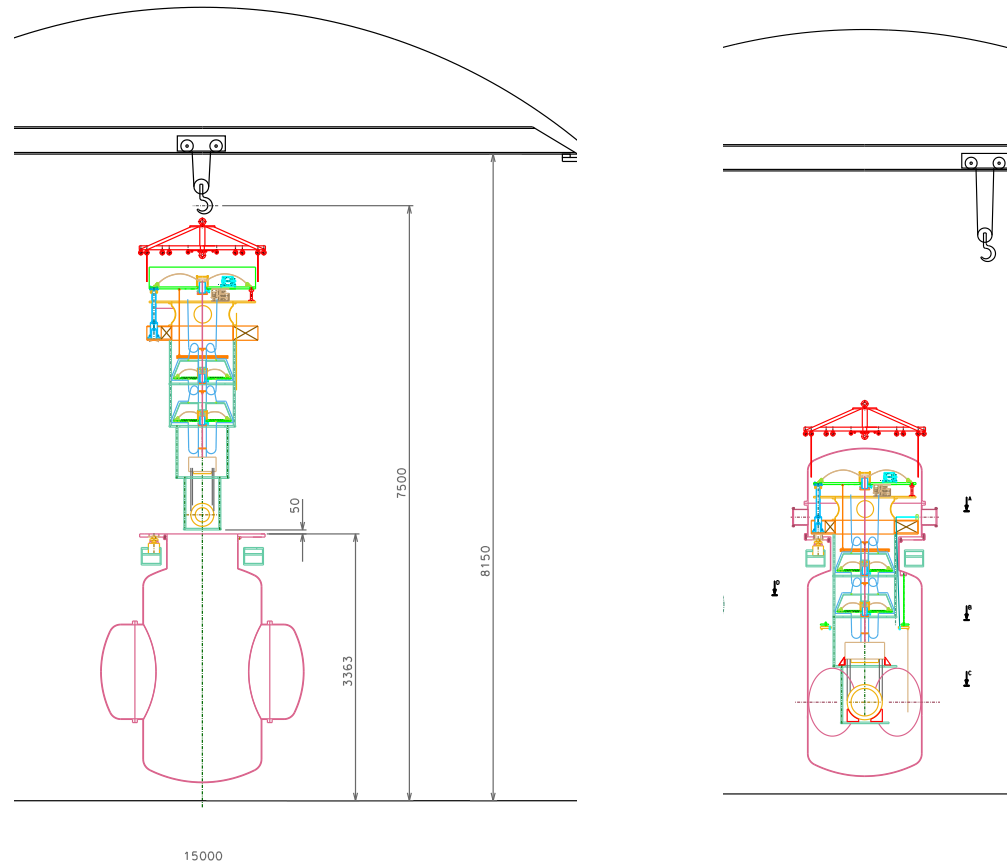



# It is a lot of work !

- Do we really need to make all of that work in the close confines of a tunnel?
- Can we do the assembly outside and then move it in its container after assembling cabling and testing?



# Can we move it

- Moving it straight up is too tall for a truck
- Turning it on a side for shipment would damage the tilt actuators

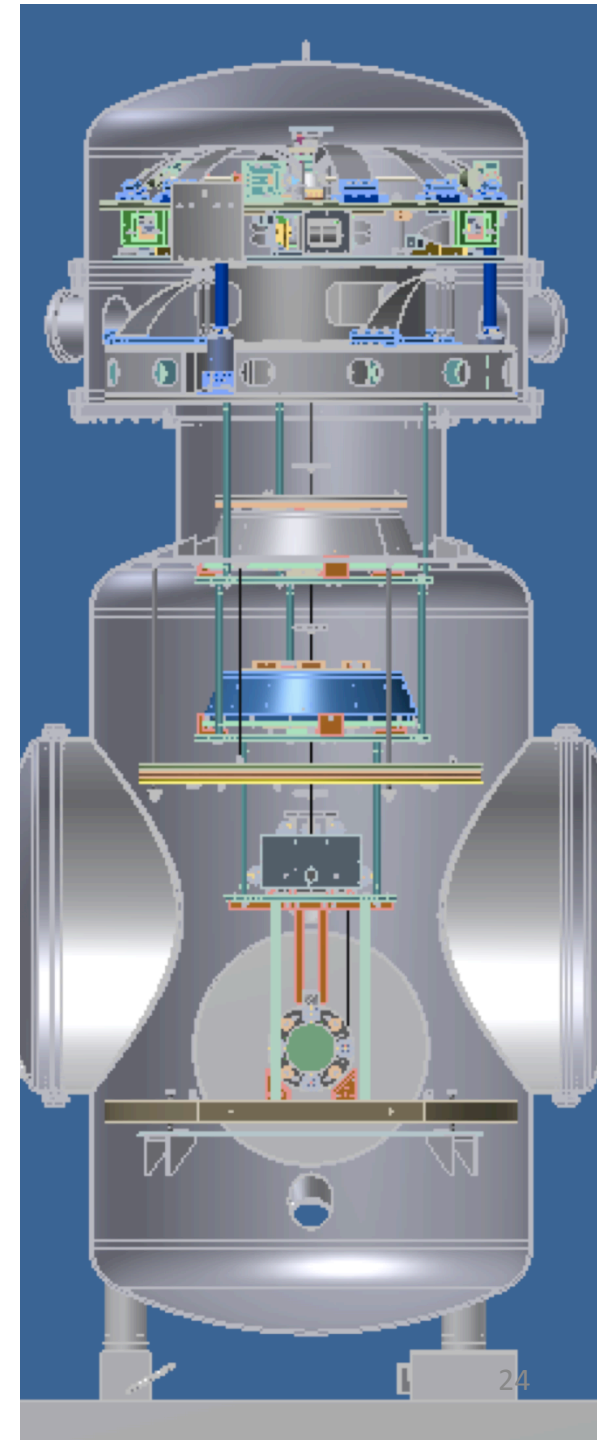





# This is possible !

- If we divide Type-B SAS from its vacuum tank we can transport as two semi-finished units, and **rapidly** re-install

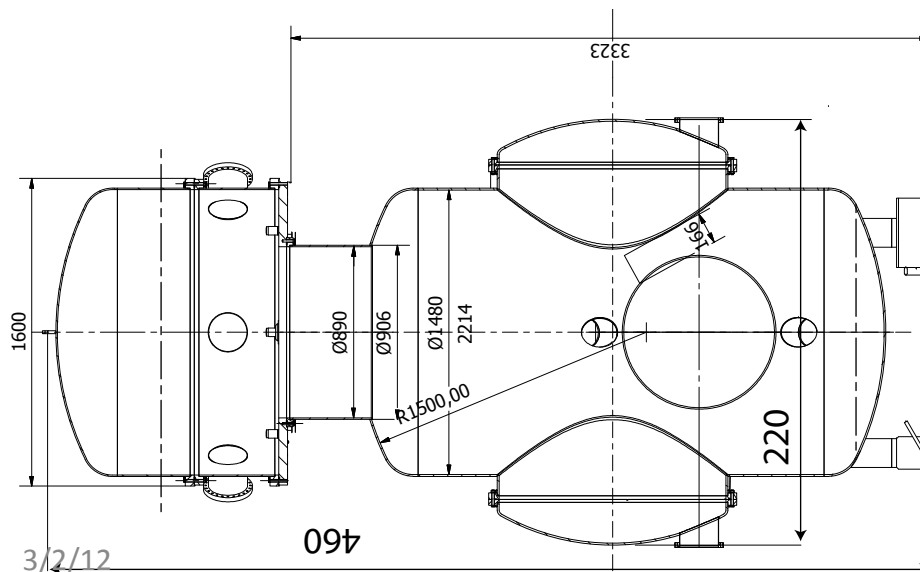



# Useful alternatives

- SAS itself can fit in a container straight up and fit on a special cart and move along the 3.8 m tall tunnels
- We can fit into a special container
- Maybe it can even fit on a low-bed truck and make it travel long distance on the road

3.4 m





# Useful alternatives

- The empty tank can rotate easily and fit on a truck

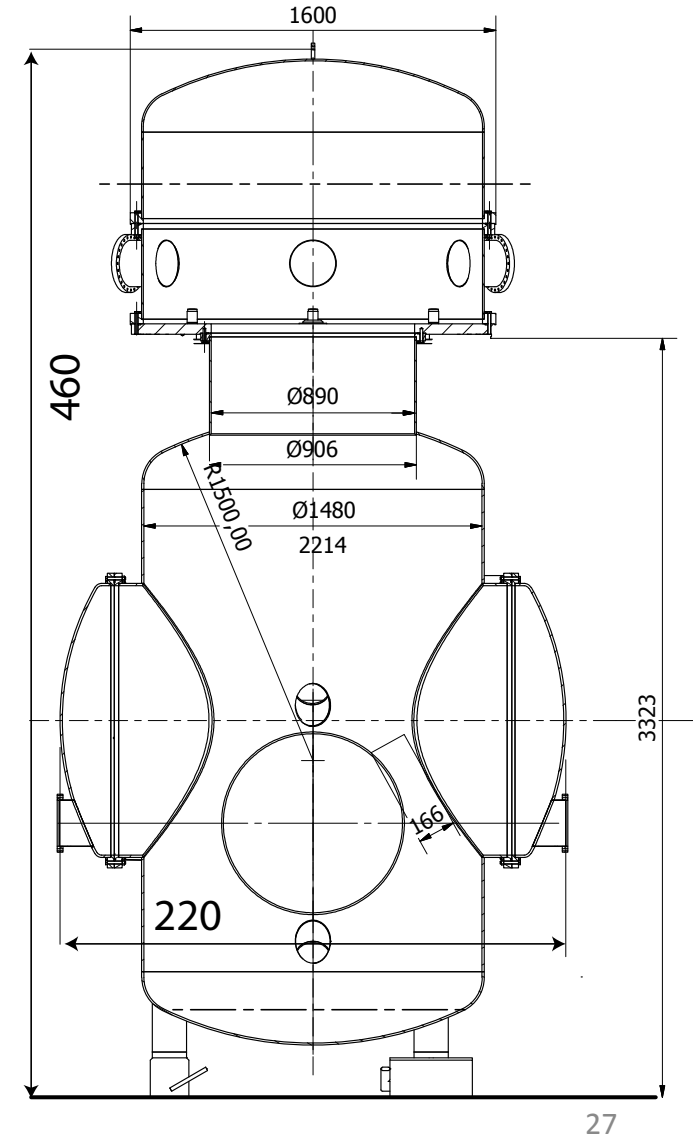
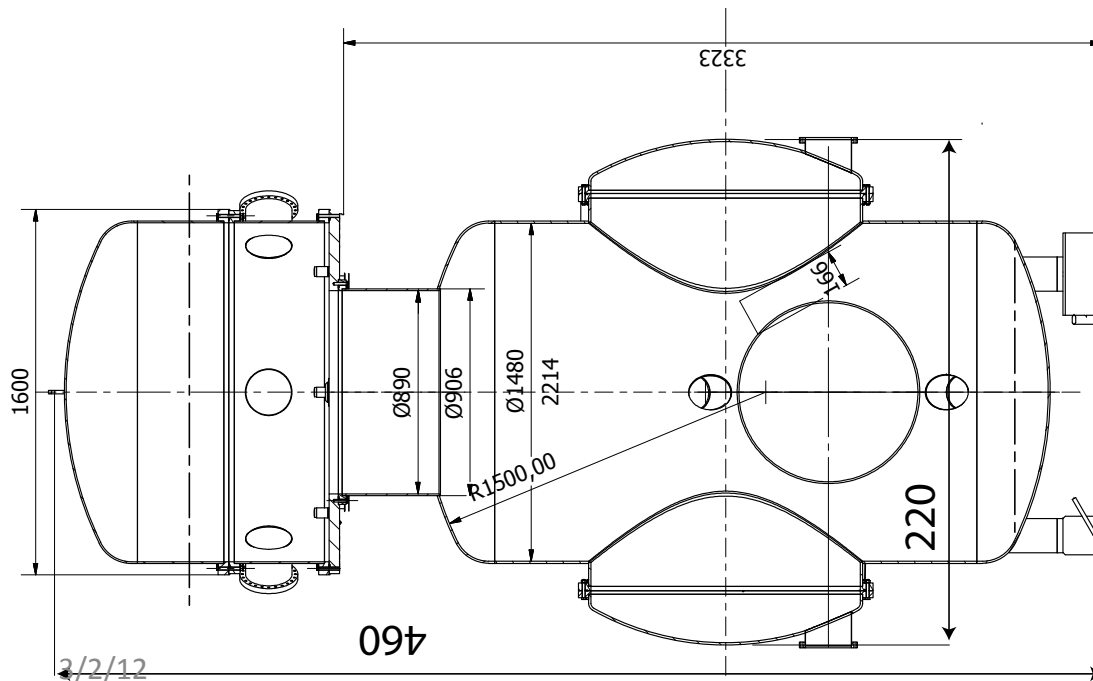



# What is the use?

- We can pre-mount and cable it
- Mount optical levers
- Early test of damping, alignment and control programs
- Perhaps mount 2 in tandem and test lock acquisition programs
- Rapidly disassemble, transport
- Rapidly re-assemble in tunnel
- It Saves a lot of time ! !

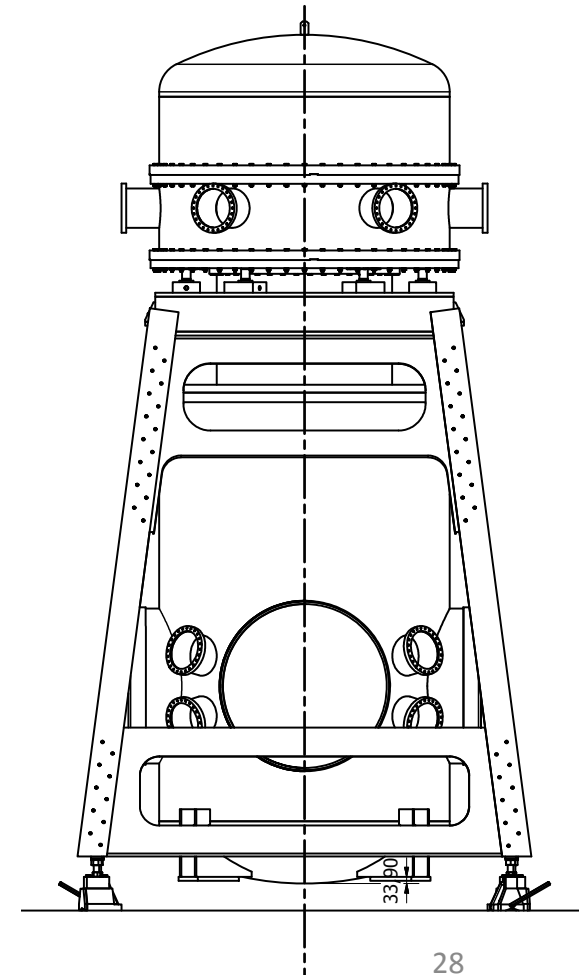



# Questions

- How tall is this tunnel?
- If tall enough perhaps we can mount SAS in itstank outside and bring in the entire in a single step ! !
- More work to do !

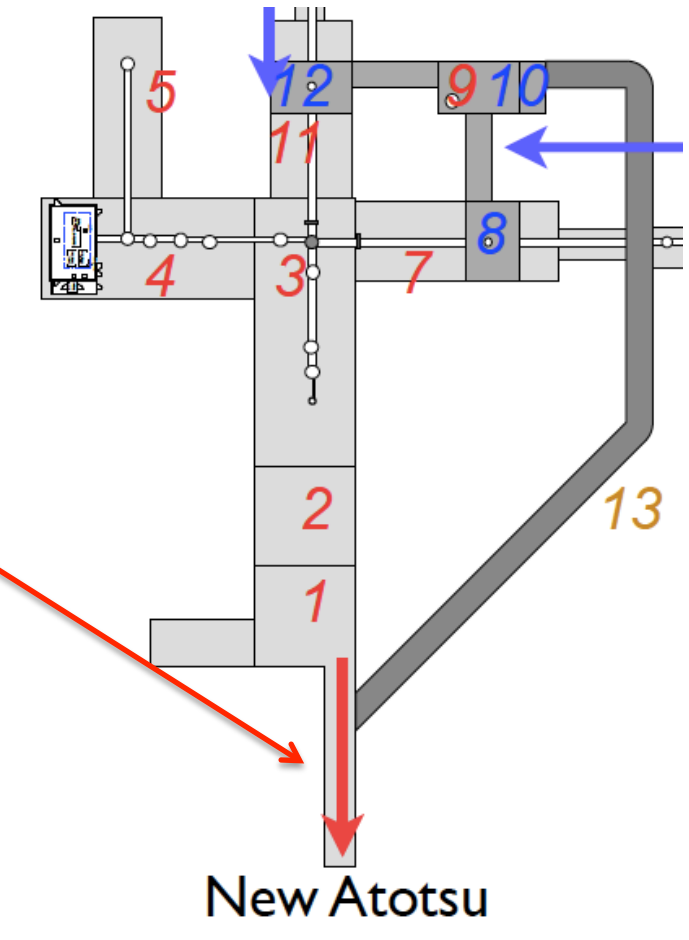



- Remote and anticipated assembly and cabling may allow:
- Early debugging and development of control strategies
- Improvements and shortenings of the roadmap
- Give more time to other tasks after tunnel is finished



# What about the beam splitter?

- No access ports
- Vertical flange to insert optical bench
- four 800 mm beam ports
- Optical levers at 45°
- Access by removing pipe

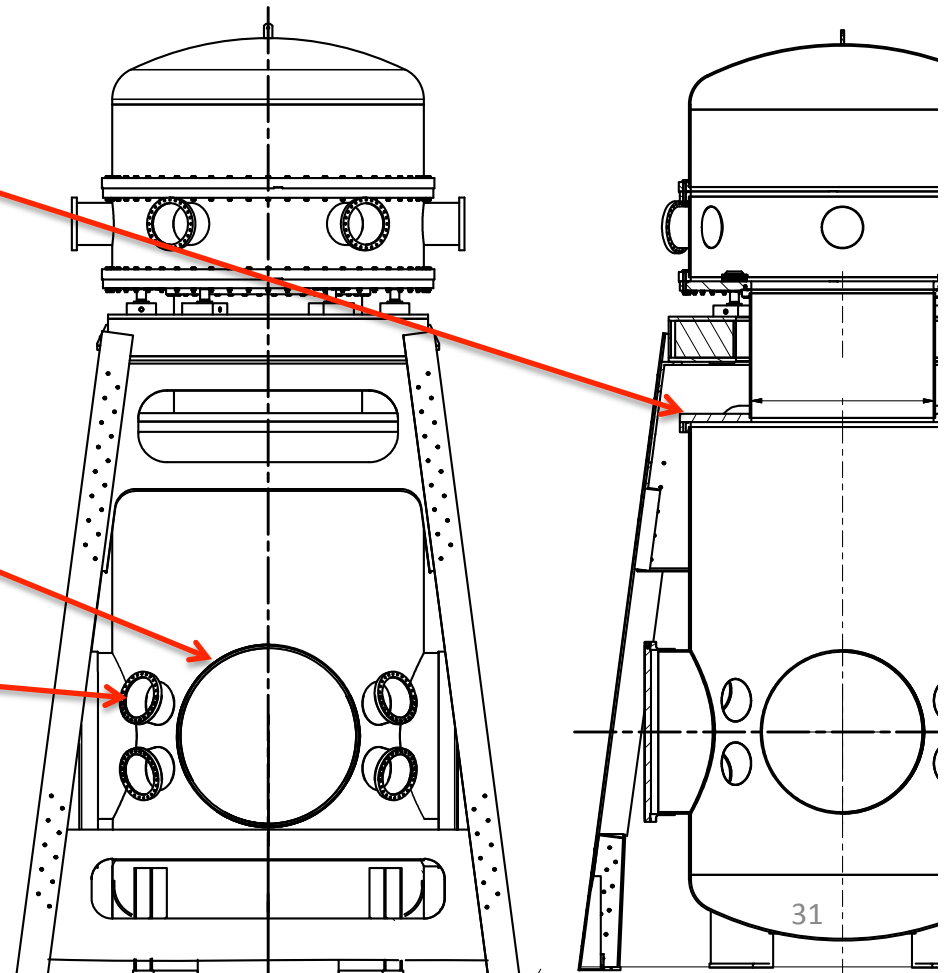



# Conclusions

- Small tanks and short chains allow remote assembly and fast implementation after tunnel completion
- Small tanks allow for easier access
- Somewhat larger tanks have less easy access (larger than one arm-length)
- Ports at 45° under external structure beams
- Much larger walk-in tanks unaffordable