

**Type-B suspension assembly sequence**, it will evolve into an assembly manual.

The magnet and wire breaker gluing jig are developed and described separately. The design of the structure to string the wires around the mirrors and recoil mass is shown in figure 1. The winch-box is mounted above the intermediate mass (which at this point of assembly is still without its recoil mass).

The mirror, which has already its magnets and wire breakers glued in place, is supported on a stand sliding below the intermediate mass.

Details of the winch box are shown in figure 2. Details of the winch unit are shown in figure 3, each winch unit has two independent winches for the forward and back wires.

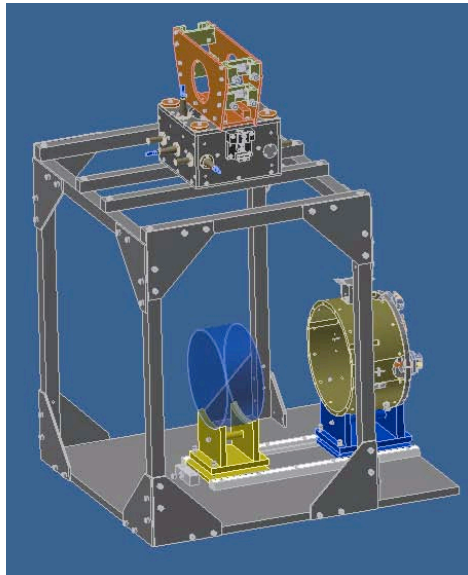

Figure 1, Wiring structure, mirror, mirror recoil mass, intermediate mass and winch box.

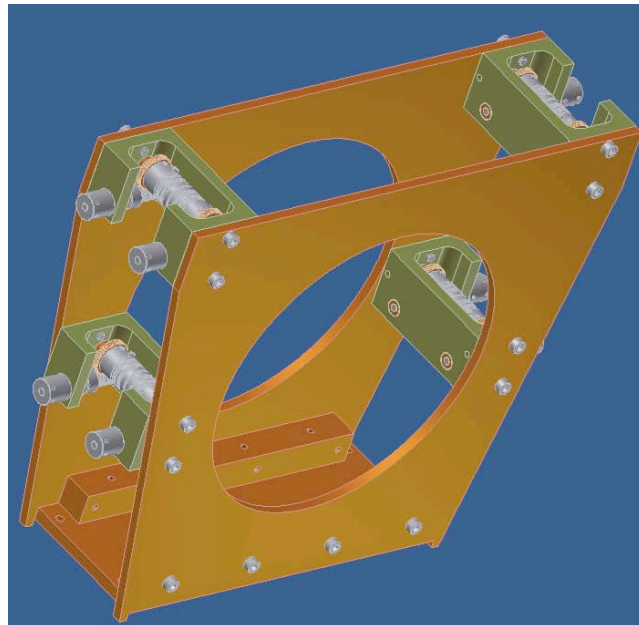

Figure 2 Winch box for the recycler mirrors.

**Mirror and recoil mass assembly sequence.**

1. The mirror is positioned first, its two wires wrapped around it, wrapped to the drum of the lower winches.
2. The winch drum has grooves used to roughly align the wires above one clamp or the other.
3. The winch are positioned so that the wires hang down slightly outside their intended final position, so that they are transversally positioned by a small notch at the upper surface of the locking pad of the weight holding clamp.
4. The wires are fed through both the middle (mirror weight holding clamp) and lower (positioning) wire clamps, around the mirror and back to the opposite winches. All four wire clamps are kept loose.
5. The wires holding the mirror are pulled to pick the weight load.
6. The stand supporting the mirror is lowered by means of the three screws and extracted.
7. The mirror is aligned by means of laser optical levers and optical survey tools.
8. The middle clamp is locked to hold the mirror weight.
9. The bottom clamp is closed to contact by hand for transversal positioning, but not tightened.
10. The recoil mass barrel (with OSEMs) is pushed forward and positioned (Figure 4).
11. The recoil mass front plate is bolted on the recoil mass barrel.
12. The recoil mass wires are fed through the top clamp, the bottom clamp (which is further loosened and then closed back to contact), around the recoil mass, up through the other two clamps on the other side.
13. The secondary wire clamps on the recoil mass are mounted and left in contact for transversal positioning, but otherwise loose.
14. The wire ends are attached to the four winches.
15. The winches are pulled to pick up the weight.
16. The stand supporting the recoil mass is lowered by means of the three screws and extracted.
17. The recoil mass is aligned with respect with the hanging mirror.
18. The top clamp is locked to hold the recoil mass weight.
19. The bottom clamp is locked.
20. The secondary wire clamps on the recoil mass are locked
21. The magnetic whip is mounted.
22. The OSEMs are wired all the way to the intermediate mass, and their signal is nulled.
23. Final alignment cross check is performed.
24. The wires are cut and the winch box removed.
25. The mirror is immobilized inside the recoil mass by means of the locking screws.
26. The two transport brackets are bolted to the bottom of the recoil mass, then they are bolted to the side of the whip pad stand on the recoil mass.

27. The unit is ready for assembly of the intermediate recoil mass.

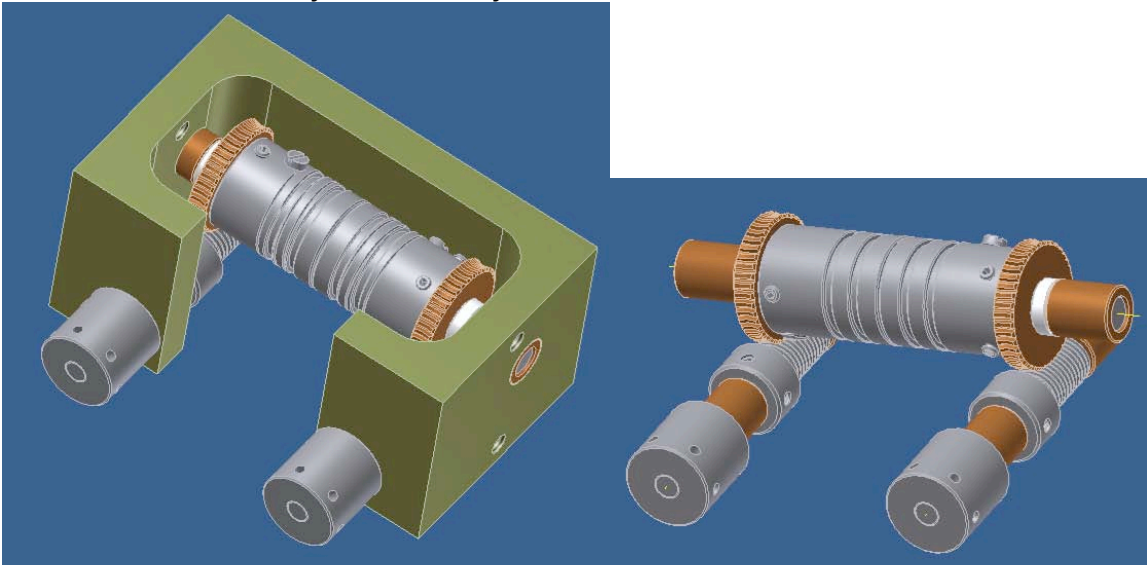

Figure 3. Winch details; each unit contains 2 independent winches. The drum of each winch has two grooves, which are used to wrap wire either for the mirror or for its recoil mass. A spiral groove allows the wire to move from the groove to a wire fastening screw.

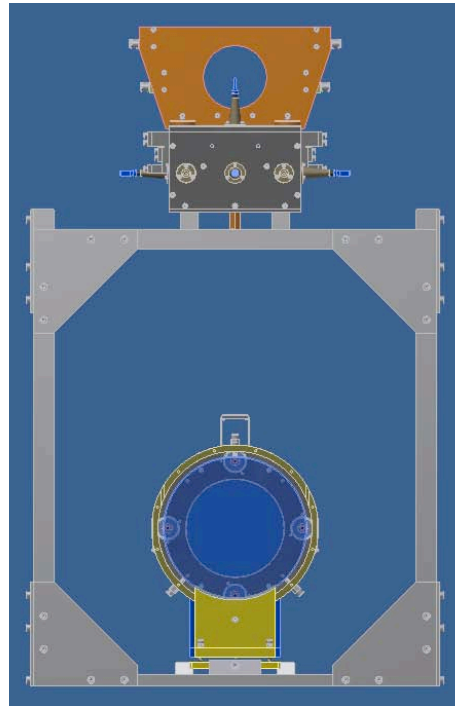

Figure 4, the recoil mass is pushed forward, around the mirror. The wires are cut below the winches, the winch box removed

After suspending the test mass and its recoil mass the intermediate mass recoil mass is added and positioned with its locking screws (figure 5). The OSEMS, both test mass and intermediate mass, are mounted, wired and tested.

Two transport bars are mounted between the intermediate mass and the mirror recoil mass. The mirror is immobilized inside its recoil mass with its locking screws. Then the mirror and intermediate mass unit are removed from the assembly structure, and moved to the next step of assembly structure.

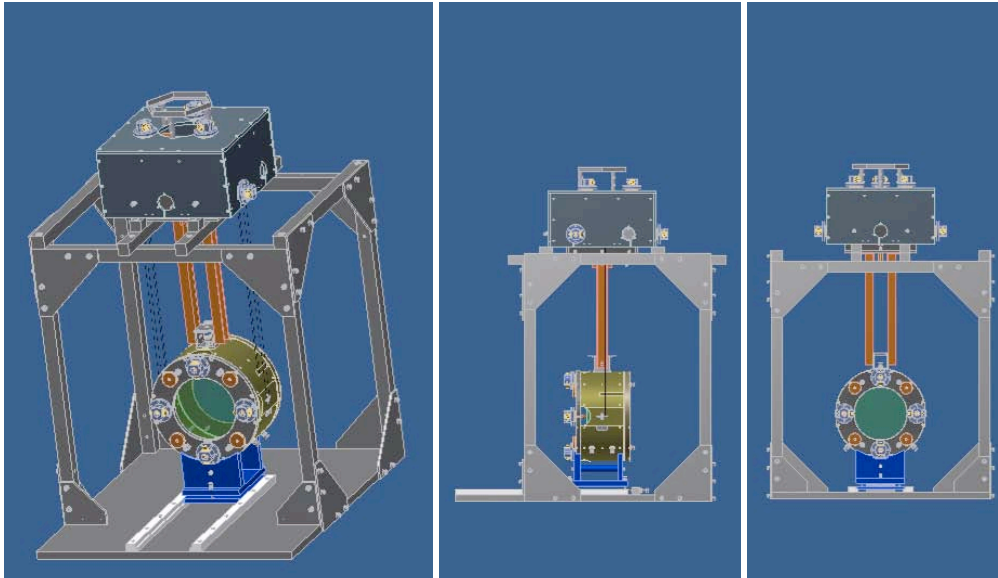

Figure 5: The intermediate recoil mass is inserted

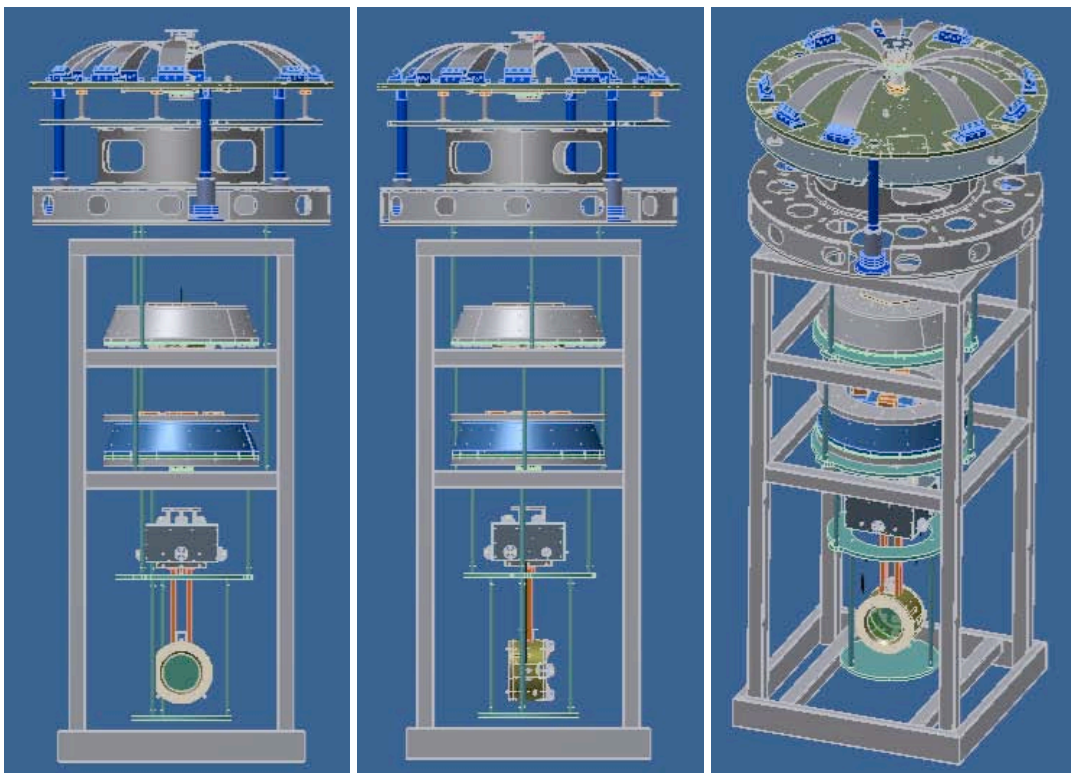

Figure 6: Structure to mount bottom filter, standard filter, and top filter-Inverted pendulum unit, as well as the safety and transport structure.

A tall assembly stand is designed to mount the bottom, standard and top filter (figure 6).

The assembly stand is designed so that the entire structure can eventually be lifted off with the crane from the top.

The entire operation is made in a clean room.

The Type-B chain assembly is as follows.

### **Type-B chain assembly sequence.**

1. Brackets are attached to the lower floor of the assembly stand.
2. The safety disks of test mass, intermediate mass and bottom filter are mounted together, then positioned on suitable shim blocks on the brackets.
3. The test mass and intermediate mass unit is positioned, suspended on shim blocks over the intermediate mass safety disk.
4. The locking blocks are mounted on their retracted position (lateral earthquake safety stops) on the mirror and intermediate mass safety disks.
5. The bottom filter is moved in, and supported on blocks.
6. The intermediate mass and its recoil mass are suspended from the bottom filter.
7. Cabling is propagated above the bottom filter.
8. The mirror transport bars are removed.
9. The mirror transport caps are removed.
10. Intermediate mass support blocks are removed.
11. The bottom filter is tested adding the required amount of ballast mass on the intermediate mass to make it float properly at its working point.
12. Brackets are attached to the mid floor of the assembly stand.
13. The safety ring of the standard filter is moved in and mounted on the brackets. It is connected to the lower ring with its support bars.
14. The standard filter is moved in, and supported on blocks.
15. The bottom filter is suspended from the standard filter.
16. The bottom filter locking blocks are mounted on their retracted position (lateral earthquake safety stops) on the bottom filter safety disks.
17. Cabling is propagated above the standard filter.
18. The bottom filter support blocks are removed.
19. The standard filter is tested adding the required amount of ballast mass on the bottom filter to make it float properly at its working point.
20. The top filter-inverted pendulum is moved in, and supported on blocks.
21. The safety ring of the intermediate filter is connected to the bottom of the Inverted Pendulum base structure.
22. The intermediate filter is suspended from the top filter.
23. The standard filter locking blocks are mounted on their retracted position (lateral earthquake safety stops) on the standard filter safety disks.
24. Cabling is propagated around the top filter and inverted pendulum.
25. The standard filter support blocks are removed.
26. The top filter is tested adding the required amount of ballast mass on the bottom filter to make it float properly at its working point.

27. The inverted pendulum is released and loaded with its ballast mass to tune its resonant frequency to the required value.
28. The locking clamps are engaged to lock all parts together for transport.
29. The transport caps are inserted and locked around the mirror.
30. All the brackets are removed to allow unimpeded vertical lifting of the chain.
31. A clean plastic gown is prepared around the lifting tool. The lifting tool attached to the top of the chain.
32. The clean room roof is opened to bring in the crane.
33. The Type-B attenuation chain is ready to lift off the assembly stand and out of the clean room.
34. As the chain is lifted the gown is lowered around the structure to maintain cleanliness.