

Report on Analog Electronics Subsystem

Shigenori Moriwaki

Advanced Materials Science, University of Tokyo

2011-08-04

Members:

- Tomotada Akutsu
 - Yoichi Aso
 - Souichi Telada
 - Osamu Miyakawa
 - Shinji Miyoki
-

Contents

- Tasks of Analog Electronics Subgroup
- Location of analog racks
- Components to be provided
- DC power supply
- Analog signal transfer
- Mechanical interfaces
- Schedule
- Risk management

Tasks of Analog Electronics Subsystem

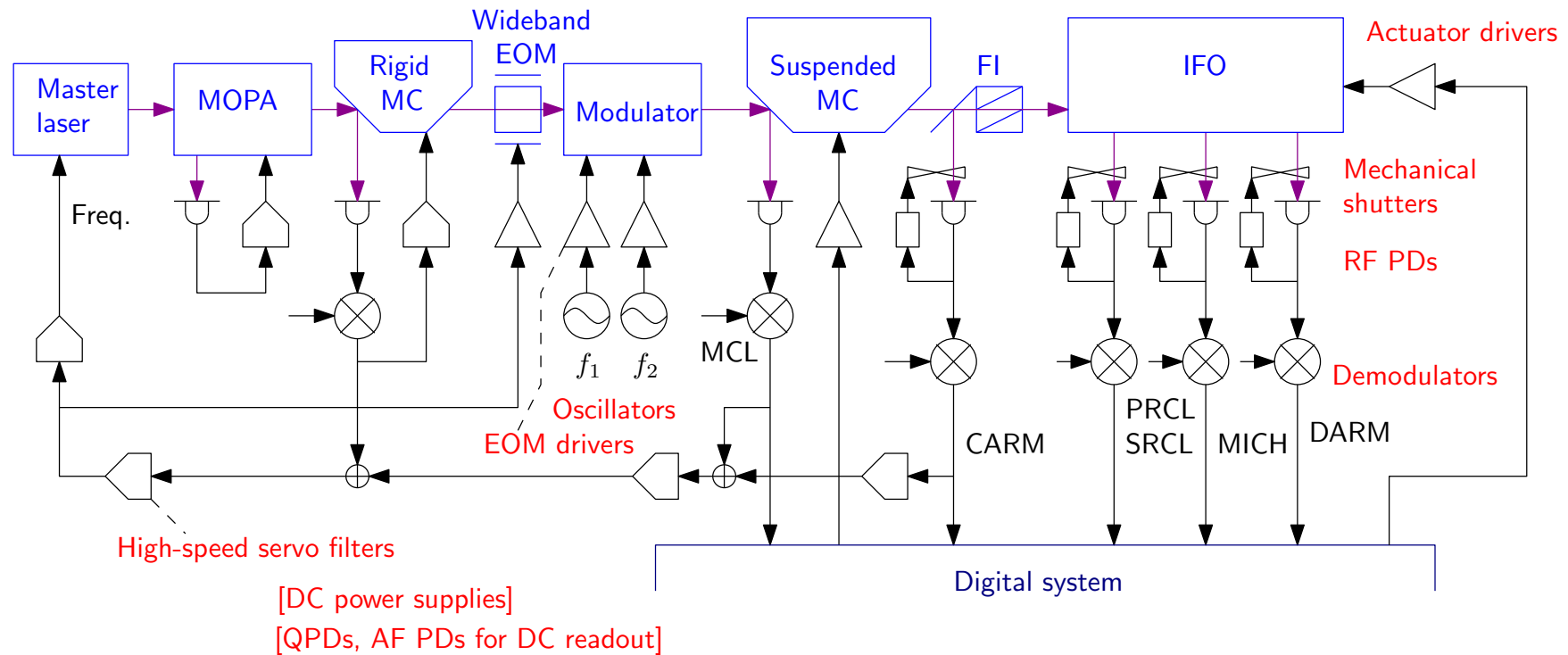

Components to be provided:

- DC power supplies
- Photo detectors
- Actuator drivers
- RF oscillators, drivers and demodulators
- Conditioning filters for ADC/DAC
- High-speed servo filters out of the digital control subsystem

Location of analog rack: center area

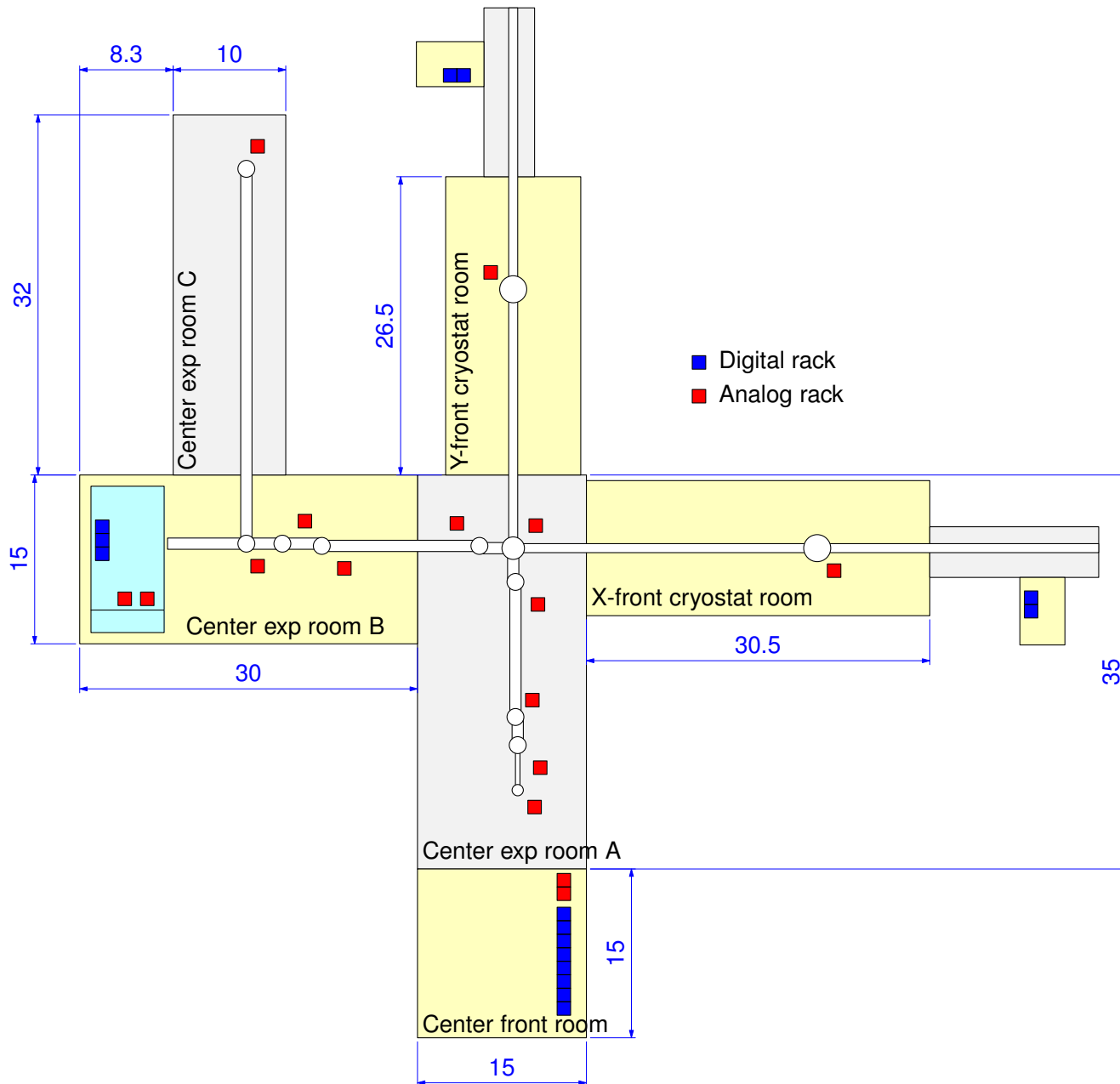

- (locations of optical benches are not determined yet)
- Analog racks should be separate sufficiently far from AC transformer and AC motors used in vacuum or cryogenic instruments.

Location of analog rack: X-end area

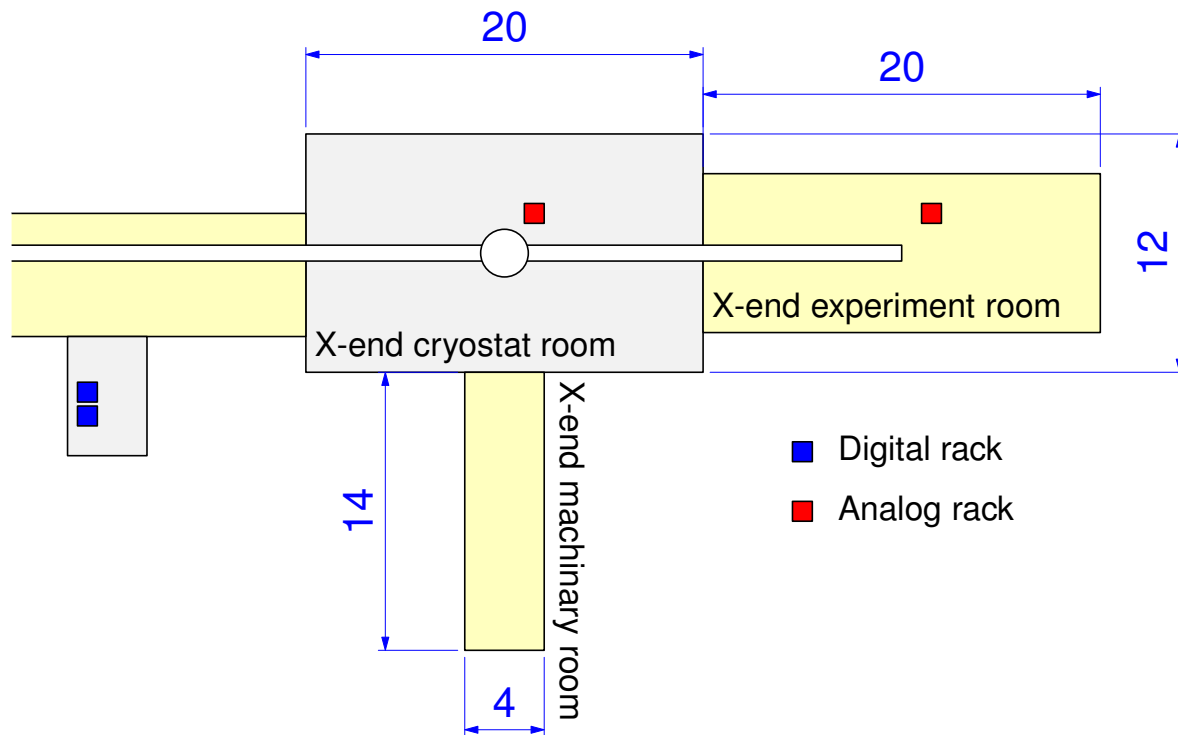

- We need the same consideration as that in the center area.

Components list (1/6) with requirements :

DC Power supplies

- Bipolar 24 V power supply [iLCGT]
- 24-to-15 V (or to-18 V) series regulator [iLCGT]
- 180 V high-voltage supply for QPD bias [iLCGT]
- High-voltage supply for coil driver [iLCGT, voltage: **TBD**]
- High-voltage supply for piezo actuator [iLCGT, voltage: 150 V (**TBD**)]
- High-current **switching mode** supply for LD driver [iLCGT]
- High-current supply for TEC (Peltier) driver [iLCGT]

Components list (2/6): Photo detectors

- RF PDs for length sensing [iLCGT, in air, in vacuum, 100 mW, ϕ 3 mm, 45 MHz or 16.875 MHz]
- AF PDs for intensity stabilization [iLCGT, in air, in vacuum]
- RF QPDs for wave-front sensing [iLCGT, 45 MHz or 16.875 MHz]
- AF QPDs for beam position sensing [iLCGT]
- Photo detectors for DC readout [bLCGT, 100 mW, ϕ 3 mm]
- Optical lever sensors [iLCGT]
- CCD imaging monitors [iLCGT]

(Common requirement: quantum efficiency >0.9)

Base design:

- TAMA300 RF PD
[N. Mio et al., Jpn. J. Appl. Phys. **40**, p.426 (2001)]
- High-power, low-noise resonant PD
[H. Grote, Rev. Sci. Instrum. **78**, 054704 (2007)]

Components list (3/6): Actuator drivers

- Piezo actuator drivers [iLCGT, 150 V]
- Wideband EOM drivers [iLCGT, few MHz bandwidth]
- Picomotor(R)/step motor drivers [iLCGT]
- Drivers for Ultrasonic motor (waveplate holder etc.) [iLCGT]
- Coil drivers for ITM-ETM [iLCGT]
- Coil drivers for SAS IP control [iLCGT]
- TEC (Peltier) driver [iLCGT]
- Electrostatic actuator driver [bLCGT]

Components list (4/6): RF System

- Stable RF oscillators [iLCGT]
- Low phase-noise oscillators [bLCGT]
- Distributors [iLCGT]
- RF resonant EOM drivers [iLCGT]
- I&Q demodulators [iLCGT, $1 \text{ nV}/\sqrt{\text{Hz}}$, 100 mV range]

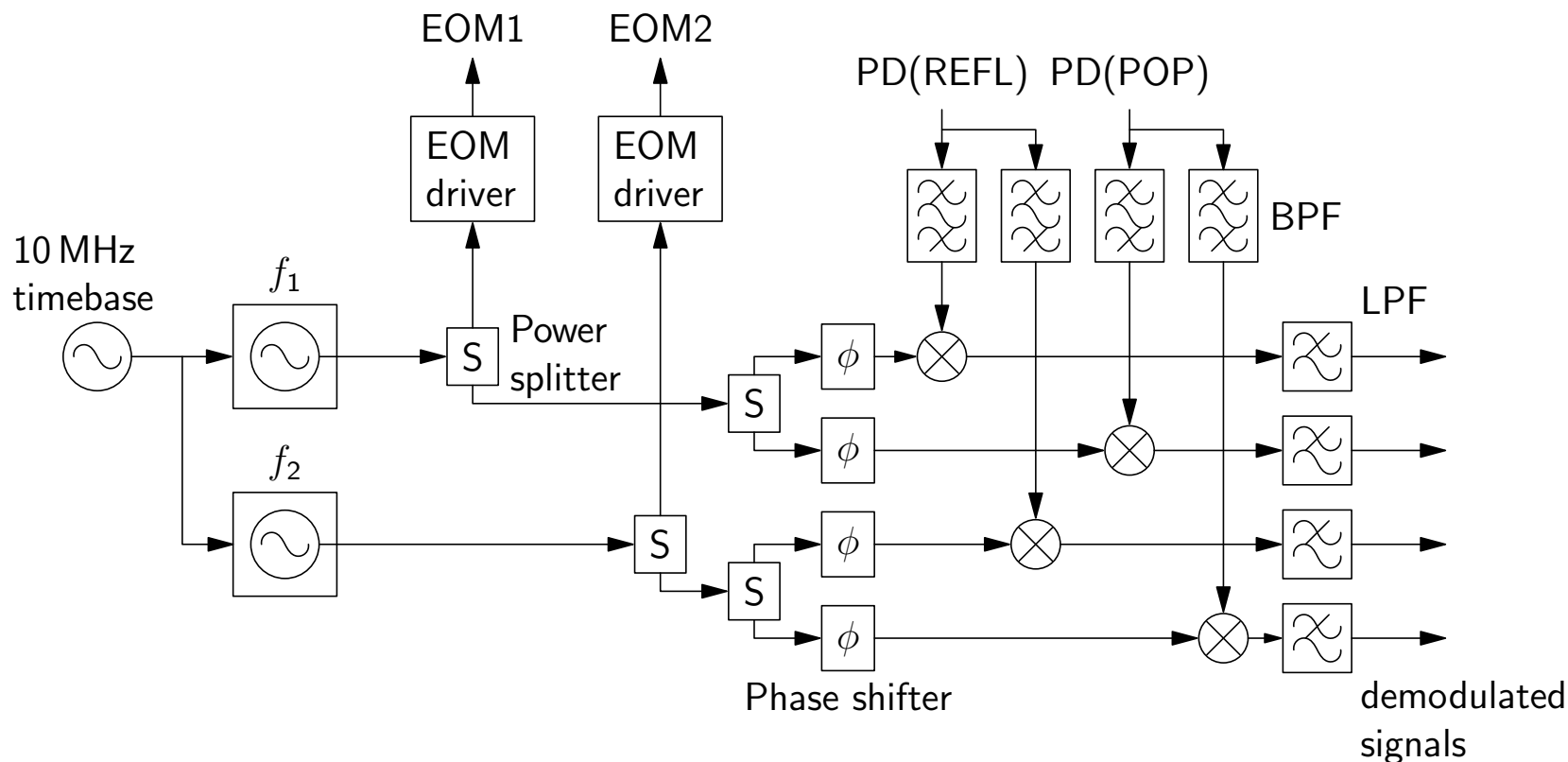

Components list (5/6): Conditioning filters for ADC/DAC

- Whitening and de-whitening amplifiers [iLCGT]
- Anti-aliasing filters in front of ADC [iLCGT]
- Anti-imaging filters for DAC output [iLCGT]

Components list (6/6): High-speed servo control filters

- Servo filters with differential input/output [iLCGT]
 - ▶ Laser frequency stabilization (NPRO piezo, wideband EOM, ...)
 - ▶ Laser intensity stabilization (LD current, EOAM)
 - ▶ Beamsplitter control for coherent addition in MOPA
 - ▶ PLL locking between fundamental and green lasers
- Feed-around summing amplifier with differential input/output [iLCGT]
- RMS threshold detector with digital interface [iLCGT]

DC power supply: overview

- $\pm 24\text{ V}$ bipolar DC power supply [Kikusui PAN35-30A]
- DC 24 V distributors
- 24-to-18 V series regulators [LM7818/7918]
- 24-to-15 V series regulators [LM7815/7915]
- 180 V (**TBD**) DC power supply for PD bias, piezo actuator, coil driver, electrostatic actuator, ...

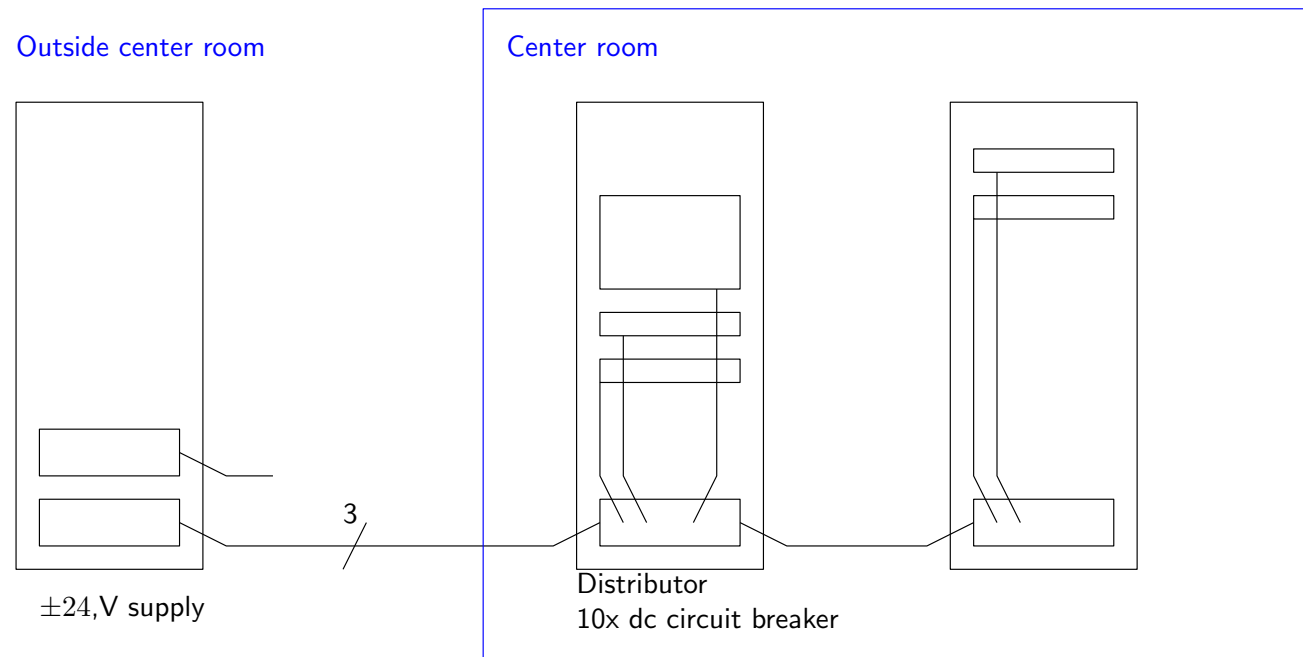

DC power supply: connectors and cables

Special care (mainly ground loop management) is required to reduce AC line noise.

- Unshielded 3-wire cable with D-sub 3W3 connector

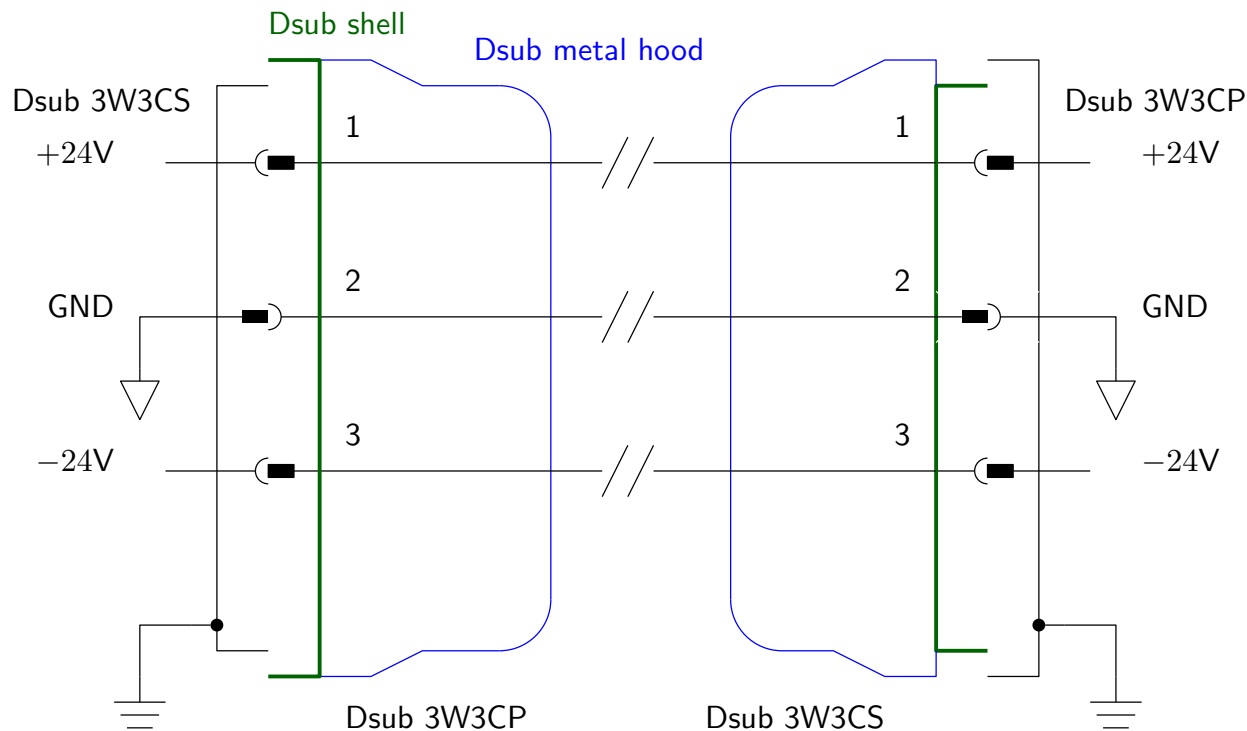

Policy on AF signal transfer

Do not transfer signals between modules with single-ended cable! Use STP (shielded twist pair) lines.

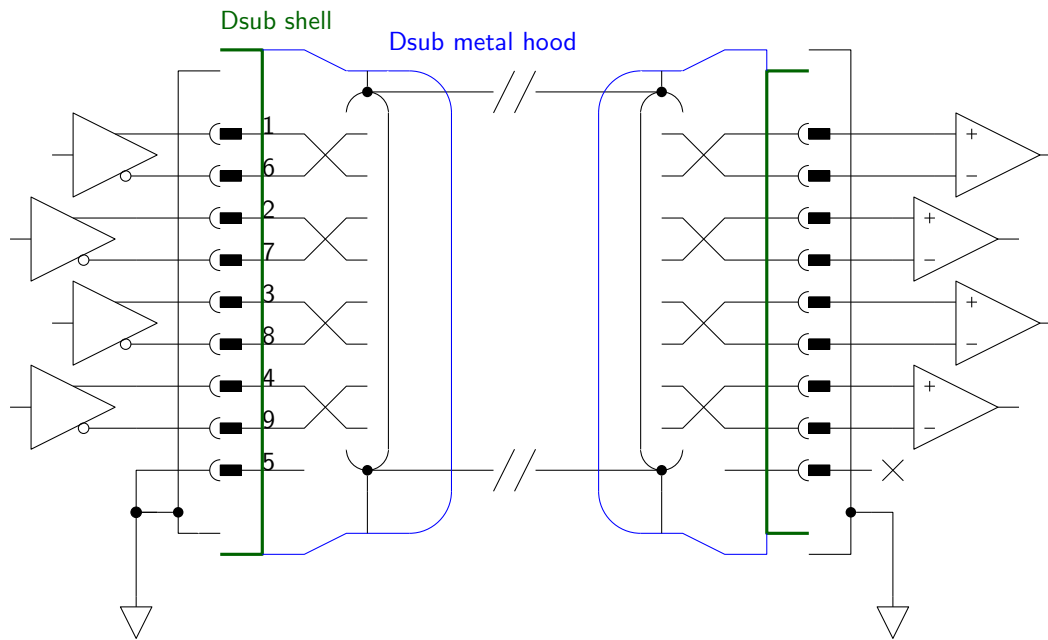

optional shield isolation adapter are used to avoid ground loops along STP shield.



STP cable with D-sub connector
- grounded at both end via receptacle shells

Chassis form for circuits: 19-inch cabinet and NIM crates/modules

- 19-inch cabinets will be used for almost all the circuits.
 - ▶ Operation under $\pm 24\text{ V}$ or $\pm 18\text{ V}$ DC power supply.
 - ▶ Take care for passive air flow cooling.
Do not use cooling fans in analog rack!
- Use of NIM (Nuclear Instrumentation Module) will be allowed.
 - ▶ Specification document: DOE/ER-0547T at <http://www.osti.gov/>
 - ▶ Vertical PCB arrangement \rightarrow effective air cooling
 - ▶ Custom crates which do not have AC 100 V transformer will be introduced. This crates provide DC $\pm 24\text{ V}$ and $\pm 12\text{ V}$ supply to the module via backplane connector.

Schedule

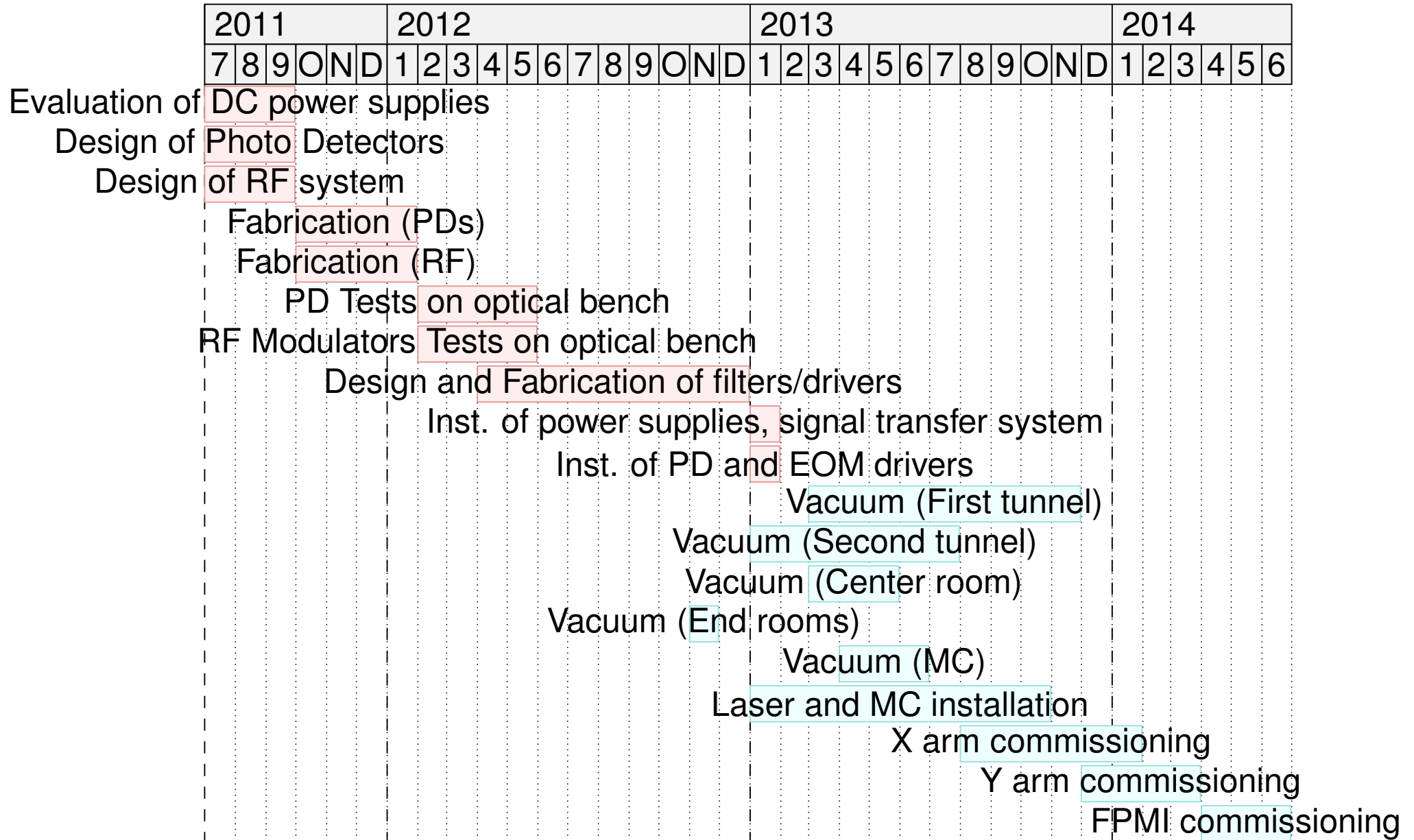

First article test

Example of AA/AI (anti-alias/anti-imaging) filter:

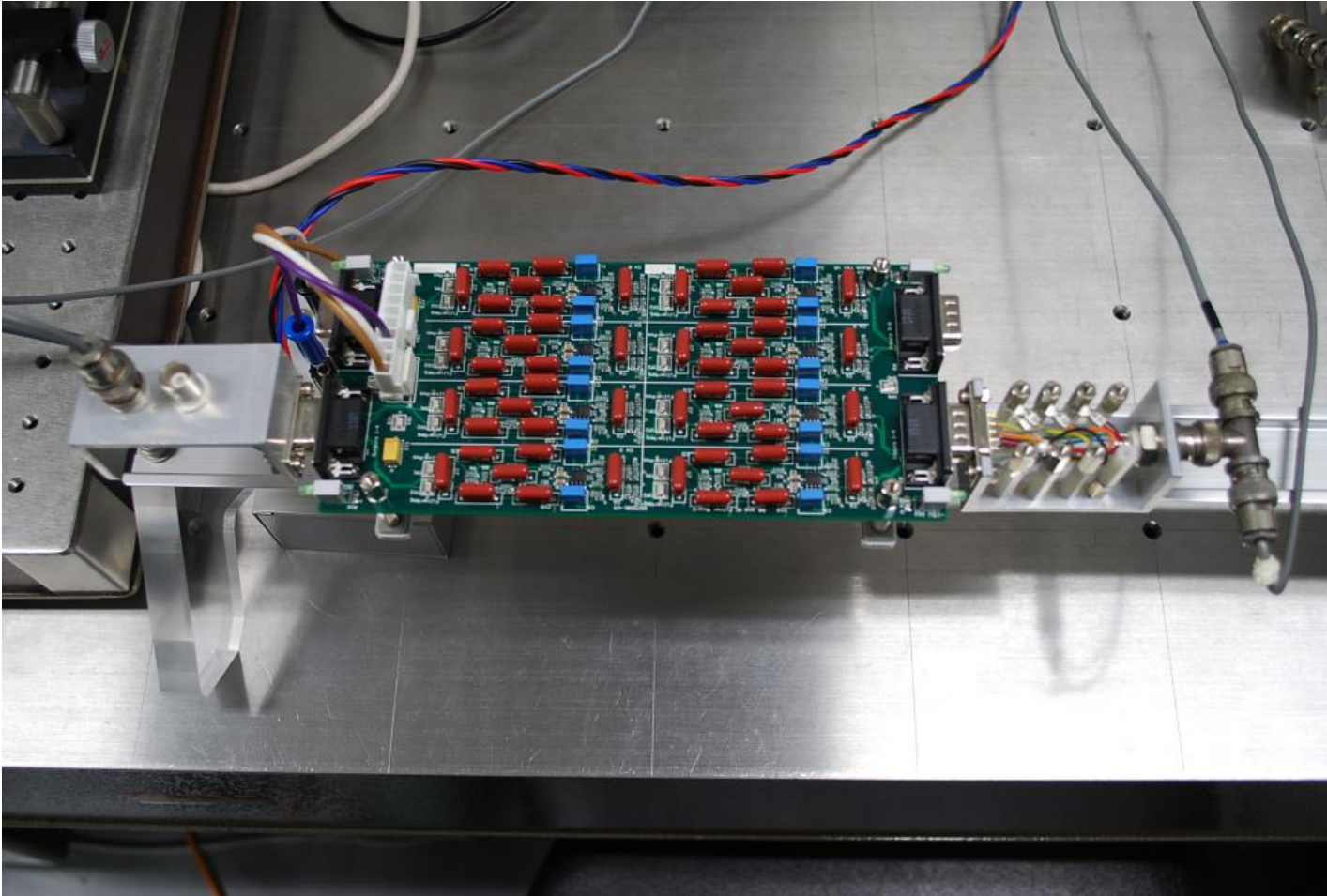

Fully-differential low-pass filter, 8 channels per a board

Risk management

- AC 60 Hz line noise
 - policy compliance for AC transformer, AC motor and grounding treatment
- RF cross-talk noise
 - design policy for cabling and routing on circuit board
- Acoustic coupling via capacitors, cables and oscillator crystals
 - policy for component selection
- The data cannot be analyzed without the configuration state of analog electronics.
 - SVN Change-log management