

FILTER'S CHAIN TYPE A
VERSION 2

IP total load 1055.5 Kg
diameter flex joint 10.23 mm
WAITING CONFIRM FROM HENNES

Suspension first wire dia 3.1 mm
 $\sigma = 769.93 \text{ N/mm}^2$
Wire's lenght 2100 mm

Suspension second wire dia 2.8 mm
 $\sigma = 775.44 \text{ N/mm}^2$
Wire's lenght 2100 mm

Suspension third wire dia 2.5 mm
 $\sigma = 788.9 \text{ N/mm}^2$
Wire's lenght 2350 mm

Suspension fourth wire dia 2.2 mm
 $\sigma = 789.2 \text{ N/mm}^2$
Wire's lenght 2085 mm

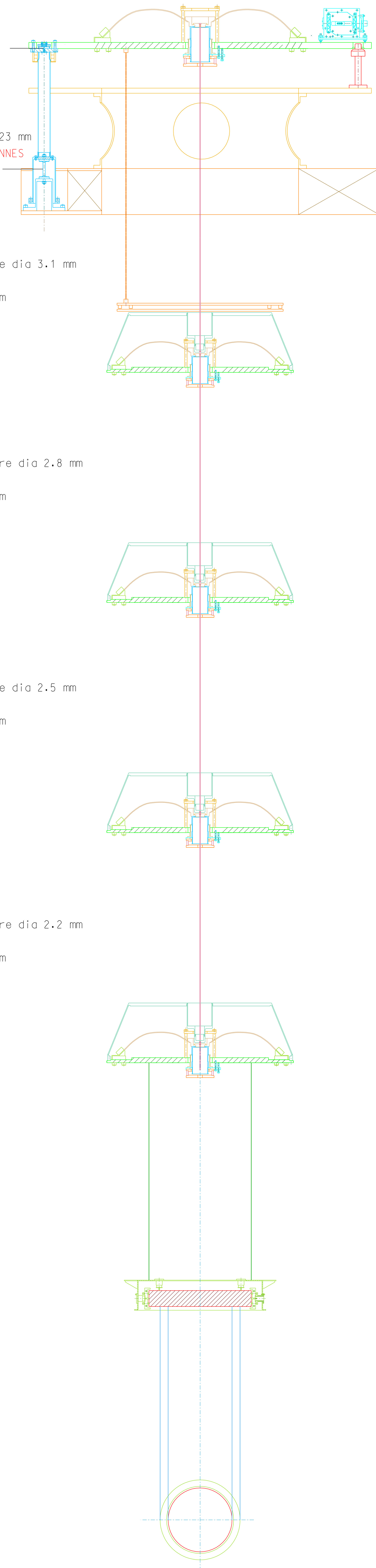
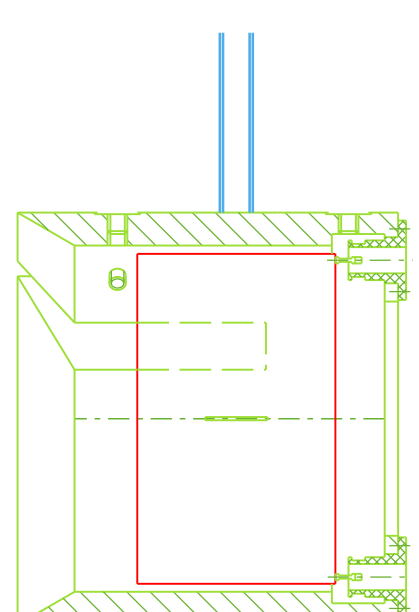

Top filter: total mass (filter+ballast=100 Kg+acceler.) 474.4 Kg
Total load on the blades 581.12 Kg
N°3 blades: t=5; W=125; l=606; load/blades 116.15 Kg
N°3 blades: t=5; W=83.47; l=606; load/blades 77.55 Kg

Filter 1: Mass 49.9+cup 38.8+ballast 4.44+ ring magnets10.5=103.64 Kg
Total load 477.48 Kg
N°10 blades: t=2.4; w=80; load/blade 40.3 Kg
N°2 blades: t=2.4; w=73.92; load/blade 37.24 Kg

Filter 2: Mass 47.13+cup 38.8+ballast 4.3=total mass 90.23 Kg
Total load 387.25 Kg
N°8 blades: t=2.4; w=80; load/blade 40.3 Kg
N°2 blades: t=2.4; w=64.36; load/blade 32.42 Kg

Filter 3: Mass 44.3+cup 38.8+ballast 4.15=total mass 87.25 Kg
Total load 300 Kg
N°6 blades: t=2.4; w=80; load/blade 40.3 Kg
N°2 blades: t=2.4; w=57.8; load/blade 29.1 Kg

Filter 4: Mass 41.47 Kg+Cup 38.8+ ballast 4=total mass 84.27 Kg
Total load 215.75 Kg
N°4 blades: t=2.4; w=80; load/blade 40.3 Kg
N°2 blades: t=2.4; w=54.2; load/blade 27.28 Kg

IRM mass 25.75 Kg
IM mass 90 Kg

Mirror mass 10 Kg
RM mass 90 Kg