

LCGT Main Interferometer Subsystem

Type B Review

2011/3/1@ICRR

Y. Aso on behalf of the LCGT MIF Working Group

Members

Y. Aso (U-Tokyo, Chair)
K. Somiya (Waseda)
O. Miyakawa (ICRR)

D. Tatsumi (NAOJ)
T. Akutsu (NAOJ)
K. Yamaoto (INFN)
K. Agatsuma (NAOJ)
M. Ando (Kyoto-U)

Y. Michimura (U-Tokyo)
E. Nishida (NAOJ)
C. Dan (NAOJ)
K. Izumi (NAOJ)

H. Yamamoto
K. Arai
K. Kawabe

Definition of the Subsystem

Main Interferometer

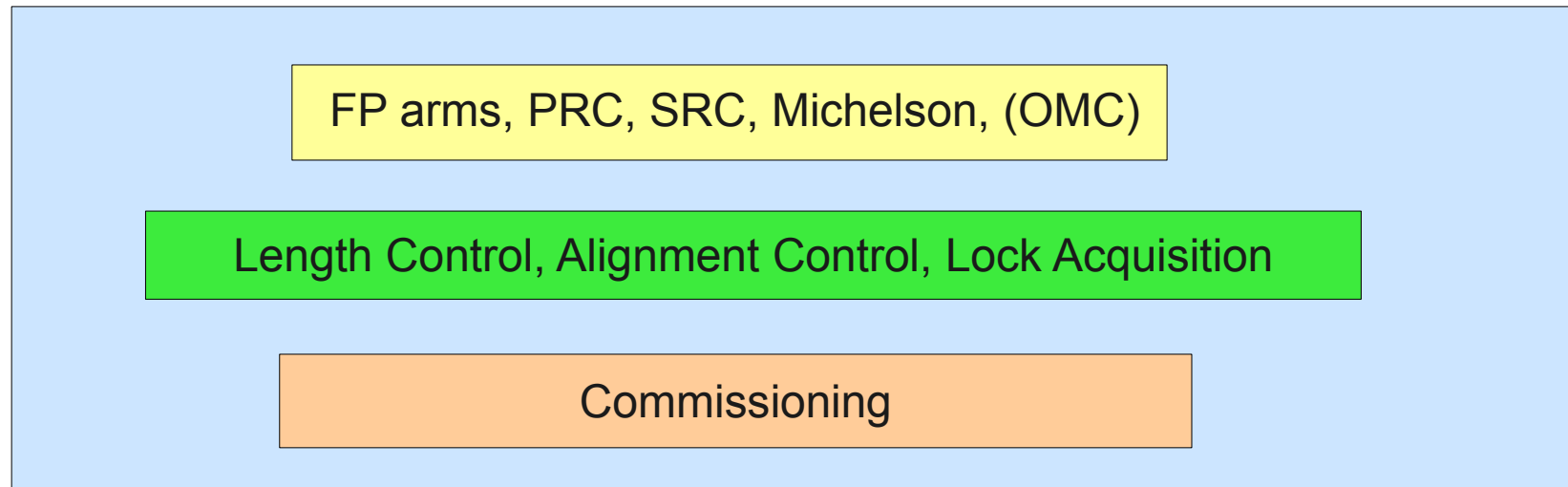

- No Hardware Manufacturing
- Design and Commissioning

Requirements

- Design an interferometer which can achieve the target sensitivity of bLCGT
- Switchable between BRSE and DRSE
- Robust operation
- Efficient commissioning

bLCGT Target Sensitivity

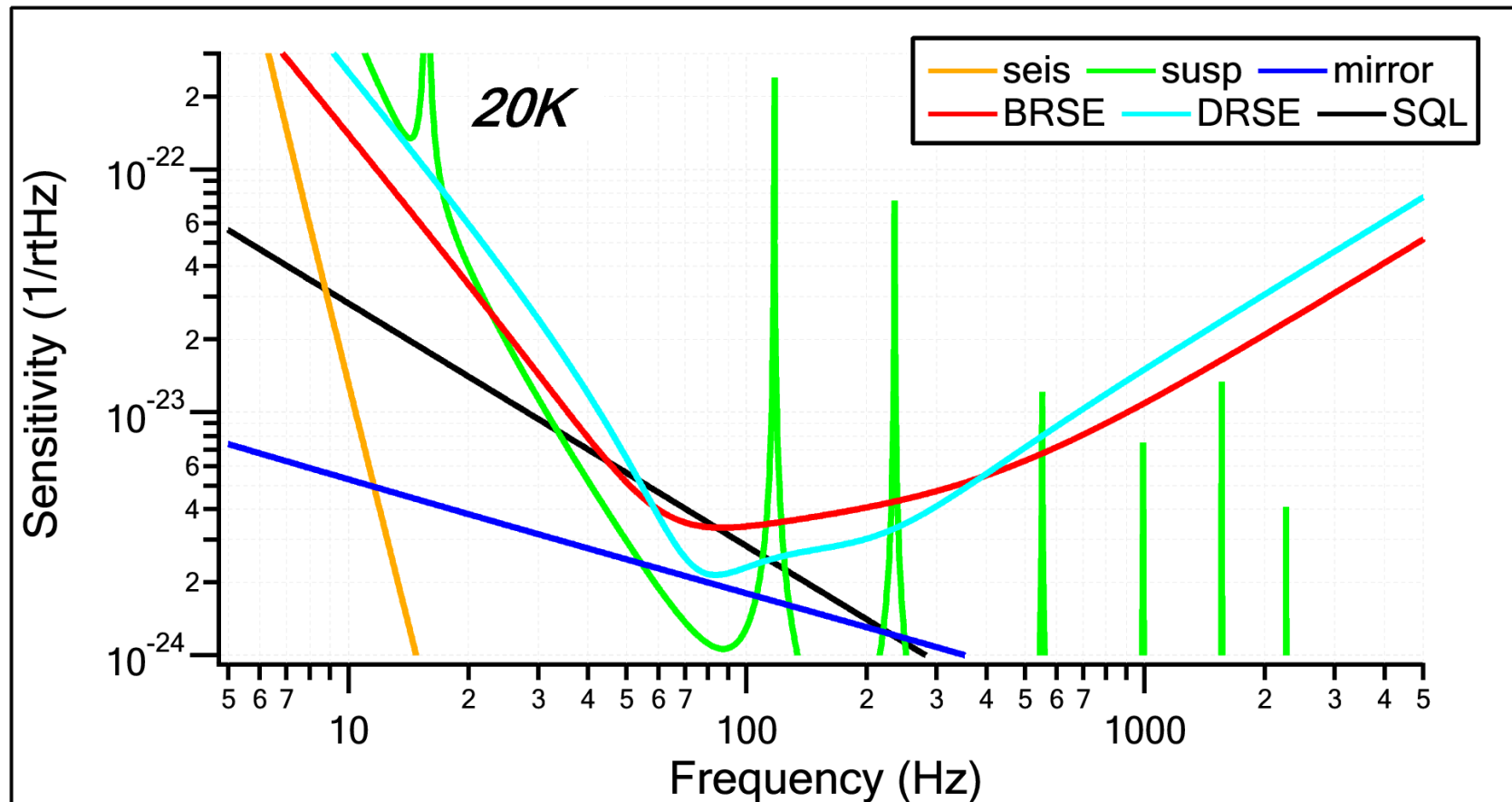

Interfaces with Other Subsystems

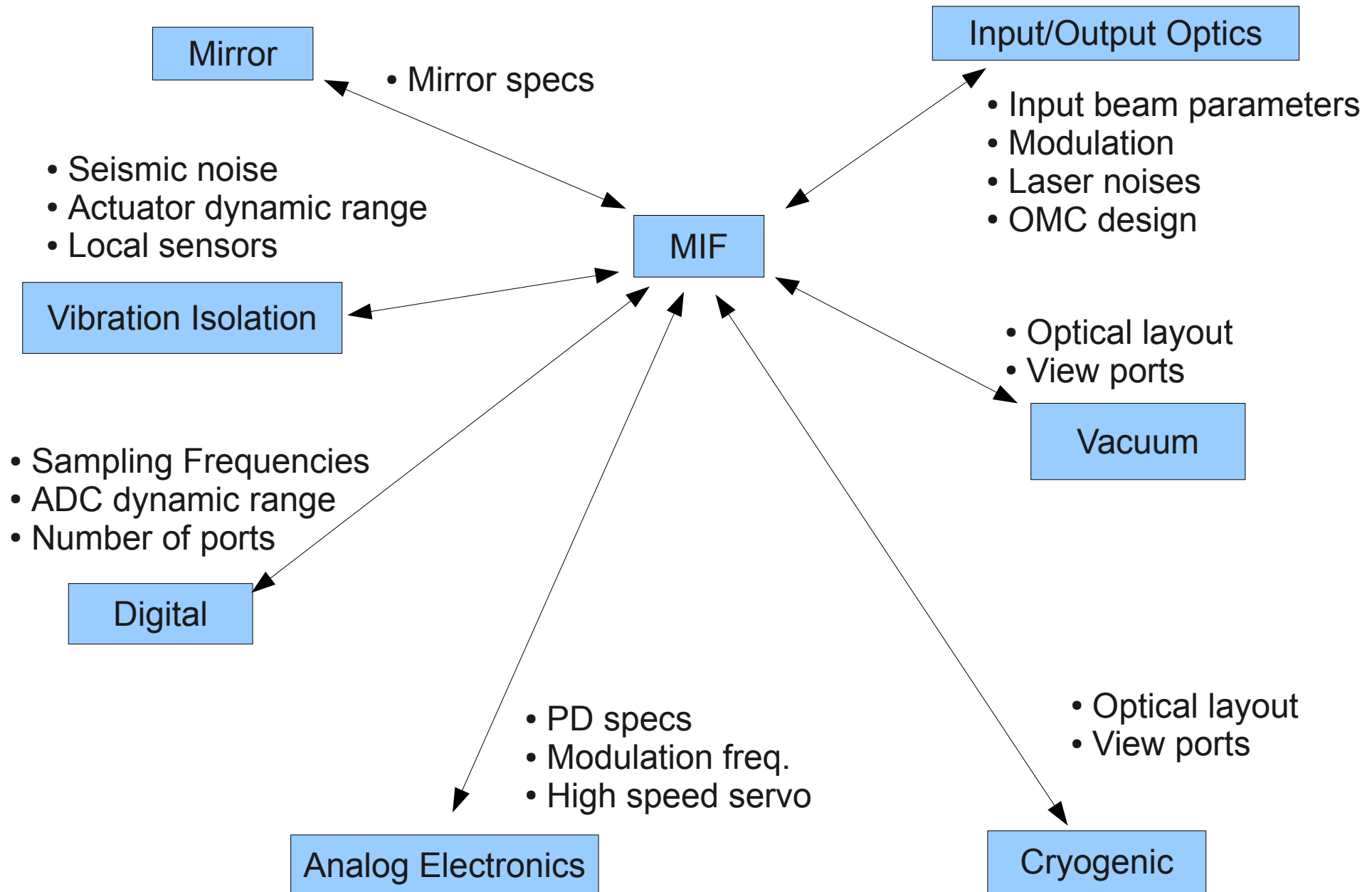

- Design of bLCGT Main Interferometer
- iLCGT design
- Activity plan during the tunnel excavation period
- Commissioning Schedule
- Risk Assessment

Main Interferometer Design

- **Arm Cavity Design**
 - Angular Instability
 - Parametric Instability
 - Higher Order Spatial Modes
- **Recycling Cavities**
 - Modulation Frequencies
 - Length Sensing Schemes
 - Folding
 - Alignment Sensing
- **Lock Acquisition Strategy**
 - Green laser pre-lock
 - 3rd Harmonics Demodulation
 - Non-Resonant Sideband
- **Optical Layout**

Overview

Dual Recycled Fabry-Perot Michelson Interferometer in RSE mode.

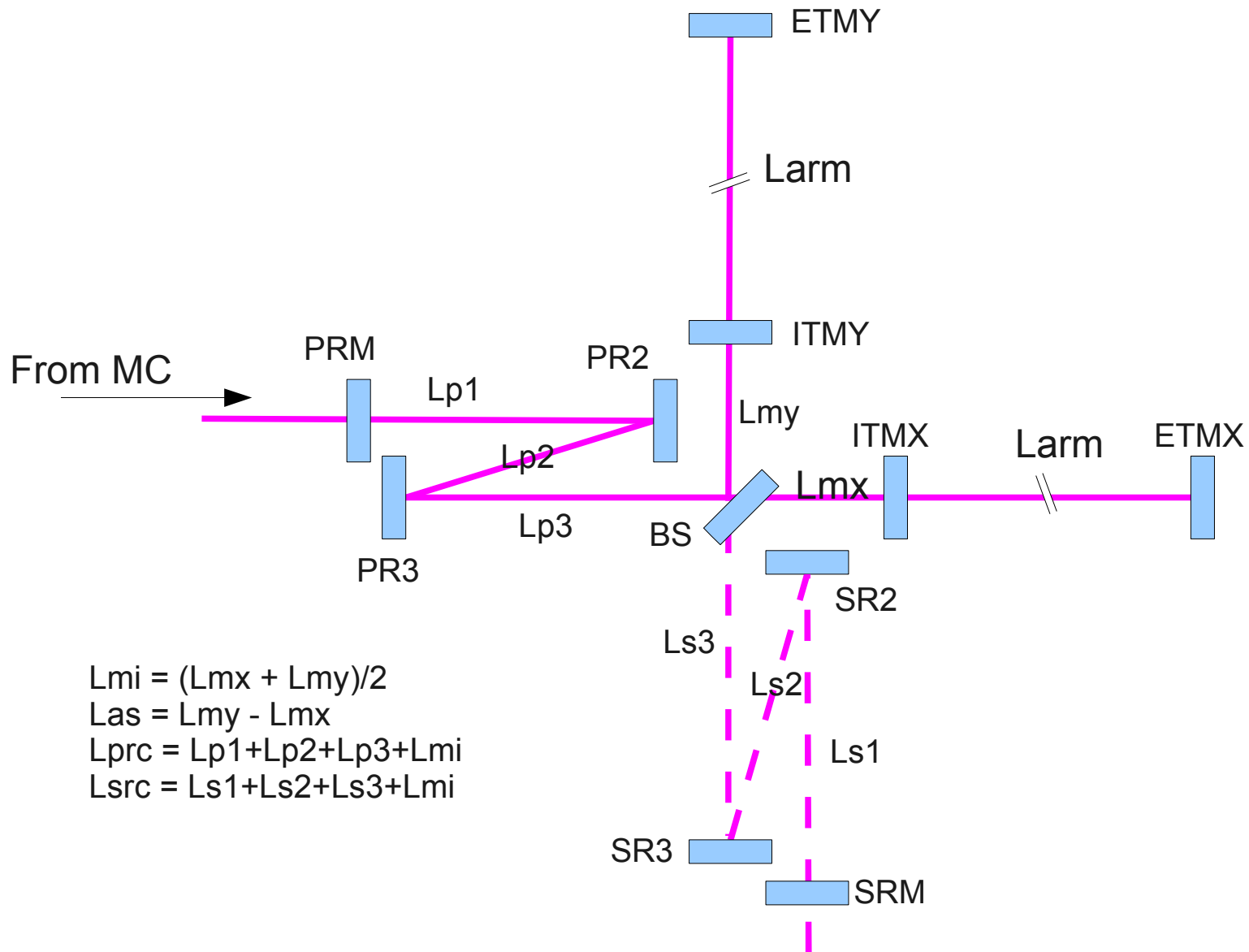

Arm Cavity Design

Parameters

- Length: 3000.00m
 - Finesse: 1546
 - **g-factor : $g_1=1, g_2=0.572$**
- Prefixed

Arm Cavity g-factor

- Spatial Mode Stability
- Beam Spot Size => Thermal Noise
- Angular Radiation Pressure Instability (Sidles-Sigg effect)
- Parametric Instability

Beam Spot Size

- Larger is Better for Thermal Noise
- 4.53cm@ETM => 0.6ppm diffraction loss
- 3.43cm@ITM
 - ITM coating is thinner than ETM
 - No problem for Thermal Noise

Angular Instability

Sidles-Sigg Stiffness Matrix

Angular Optical Spring Constant k [N*m/rad]

Large Beam (ITM=3.5cm, ETM=4.5 or 4.2cm)

4.4, -33.8 ($g_1 = 1, g_2 = 0.572$)

-4.6, 29.2 ($g_1 = -0.87, g_2 = -0.6$)

Small Beam (ITM=ETM=3.5cm)

5.0, -19.3 ($g_1 = g_2 = 0.586$)

-5.0, 19.3 ($g_1 = g_2 = -0.586$)

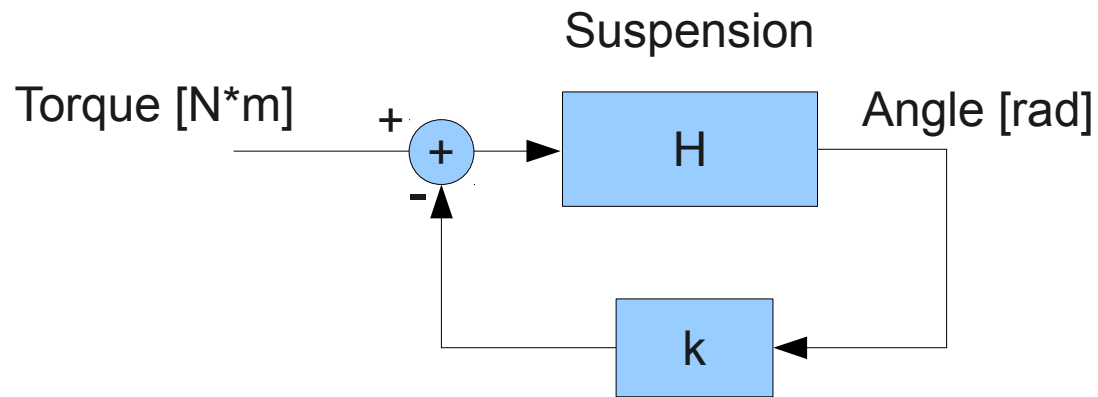

Optical angular spring constant

Open Loop Gain: $G = k \cdot H$

Check Stability

Yaw Torque -> Yaw Angle

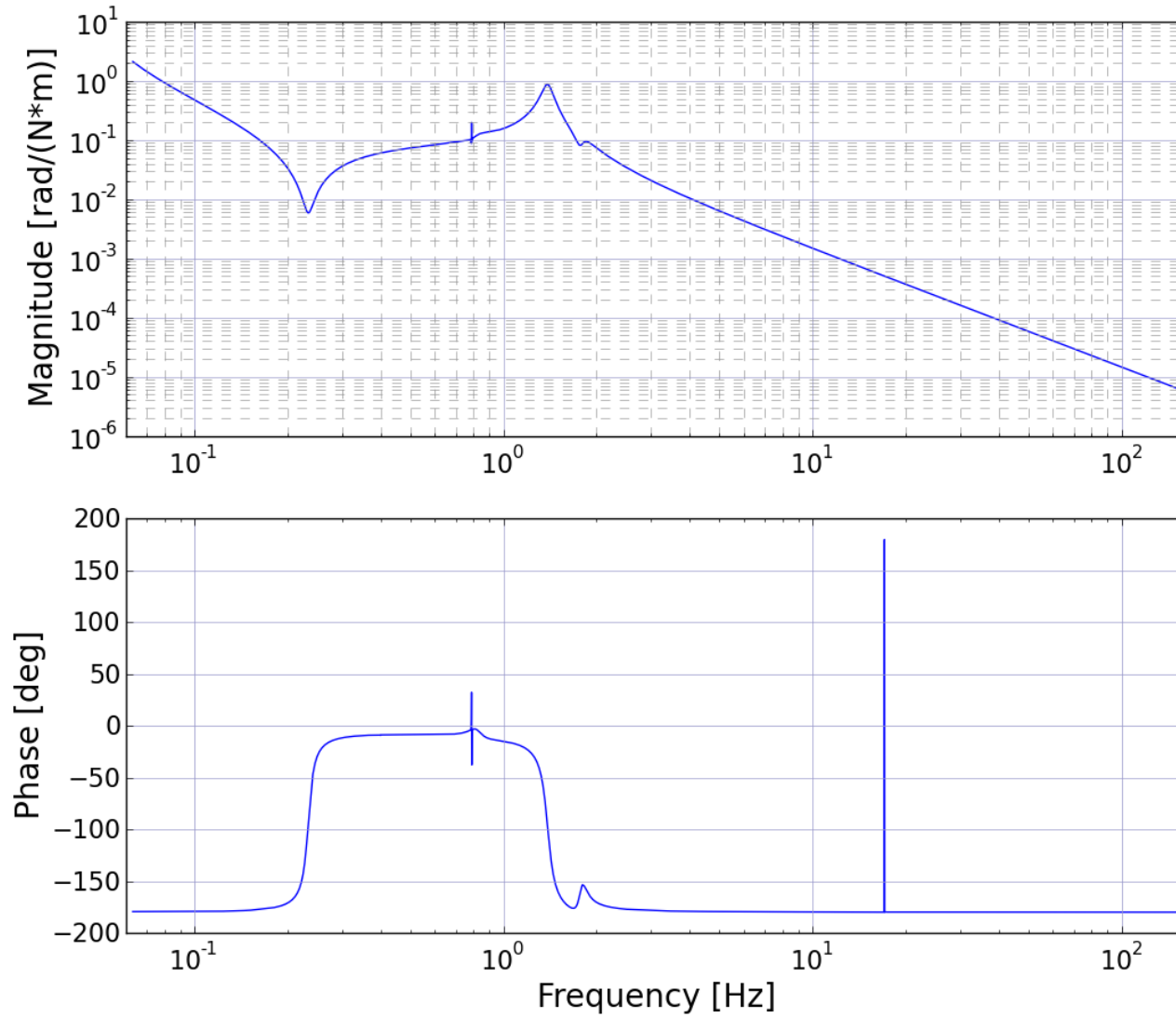

This is H

Small beam, positive ($g_1=g_2=0.586$)

Stable Eigenmode

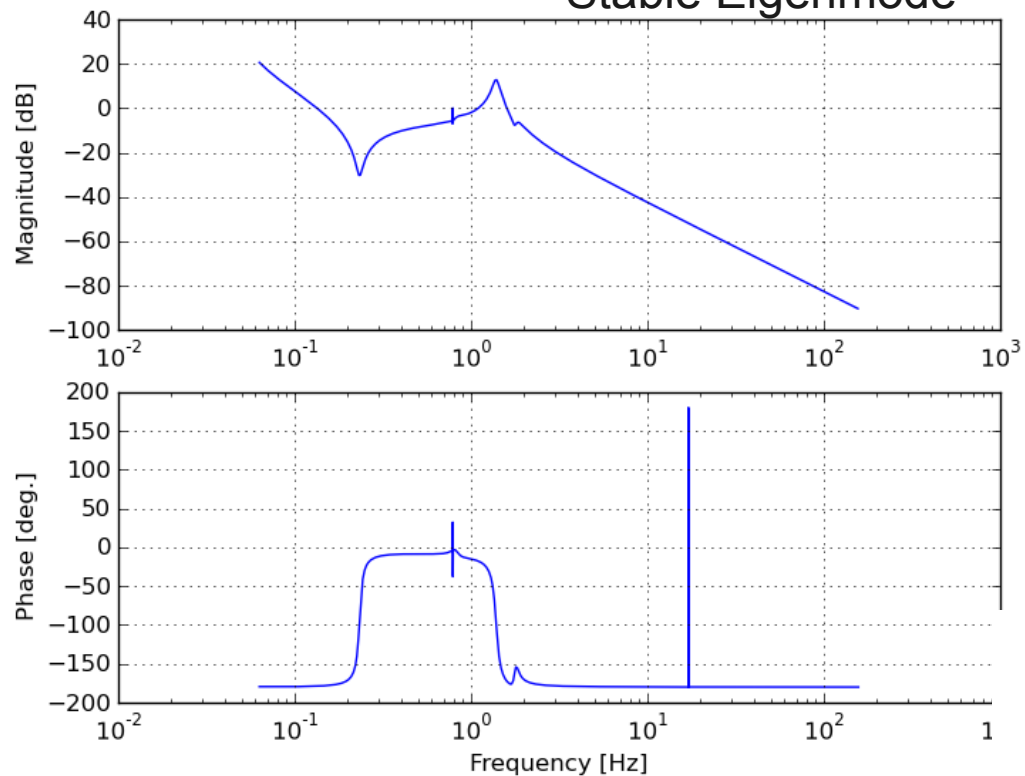

Unstable Eigenmode

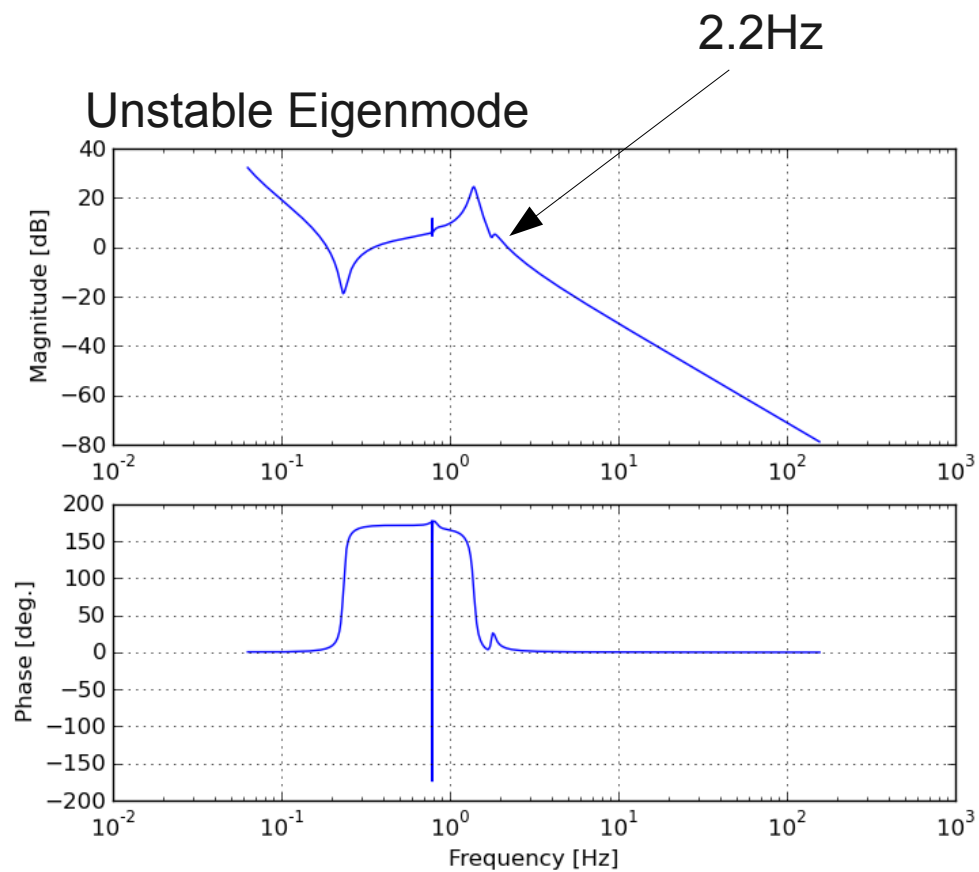

Small beam, negative ($g_1=g_2=-0.586$)

Stable Eigenmode

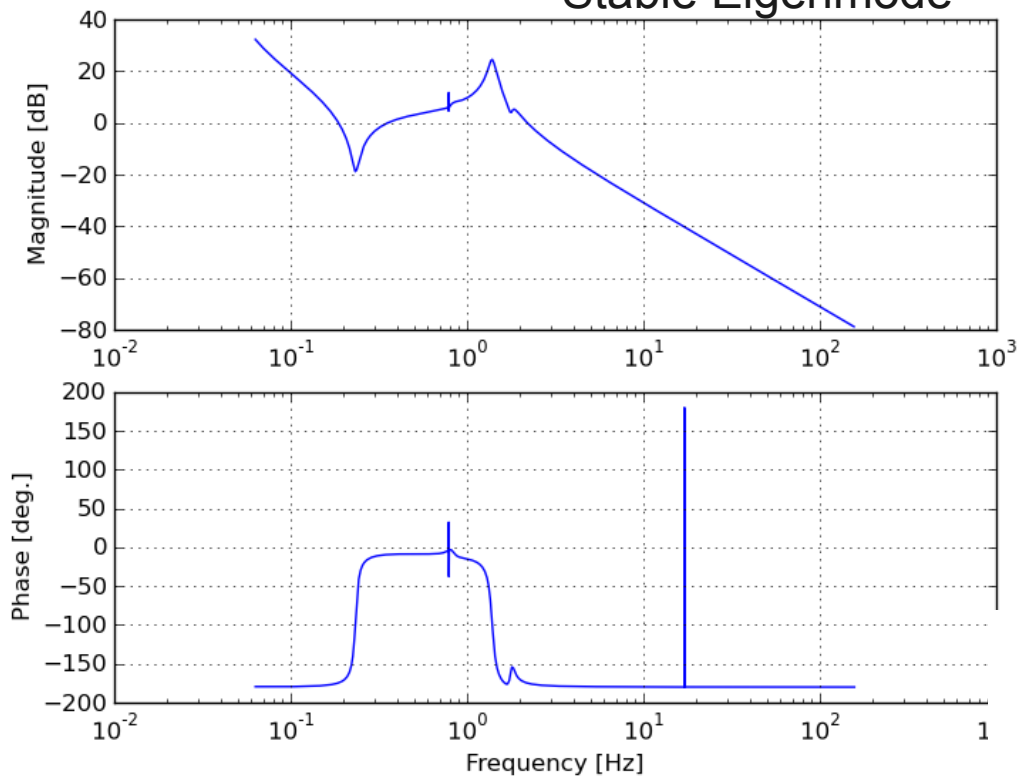

Unstable Eigenmode

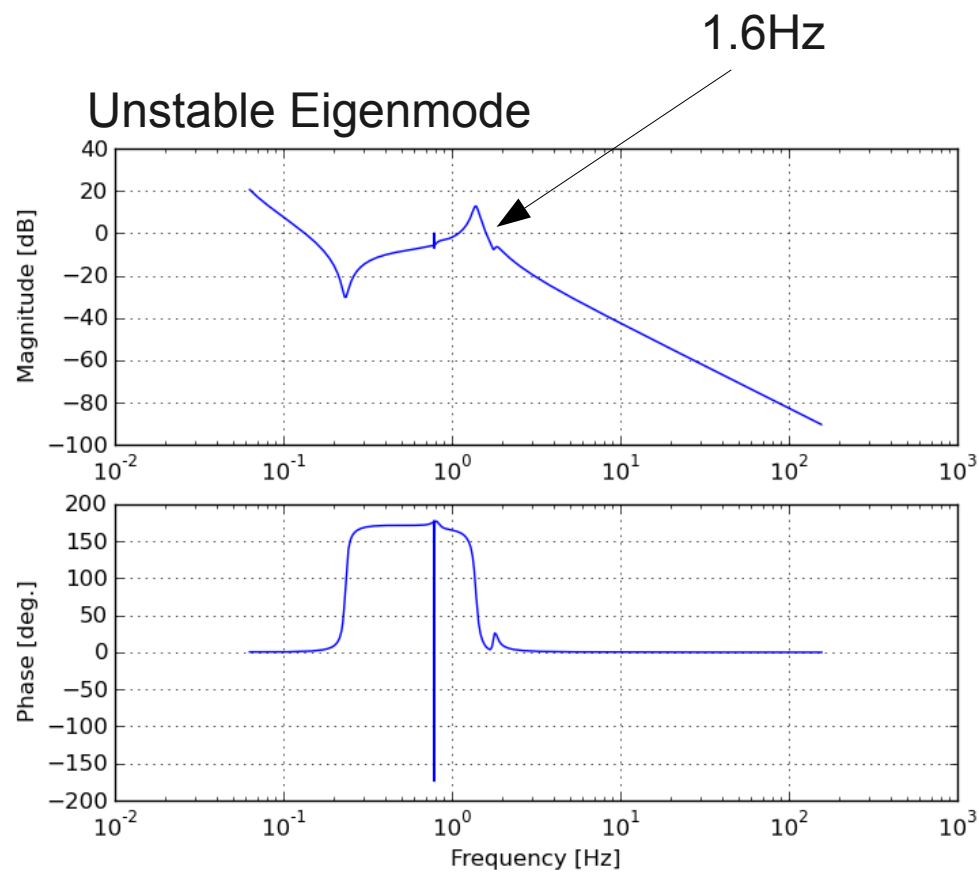

Large beam, negative ($g_1=-0.87, g_2=-0.6$)

Stable Eigenmode

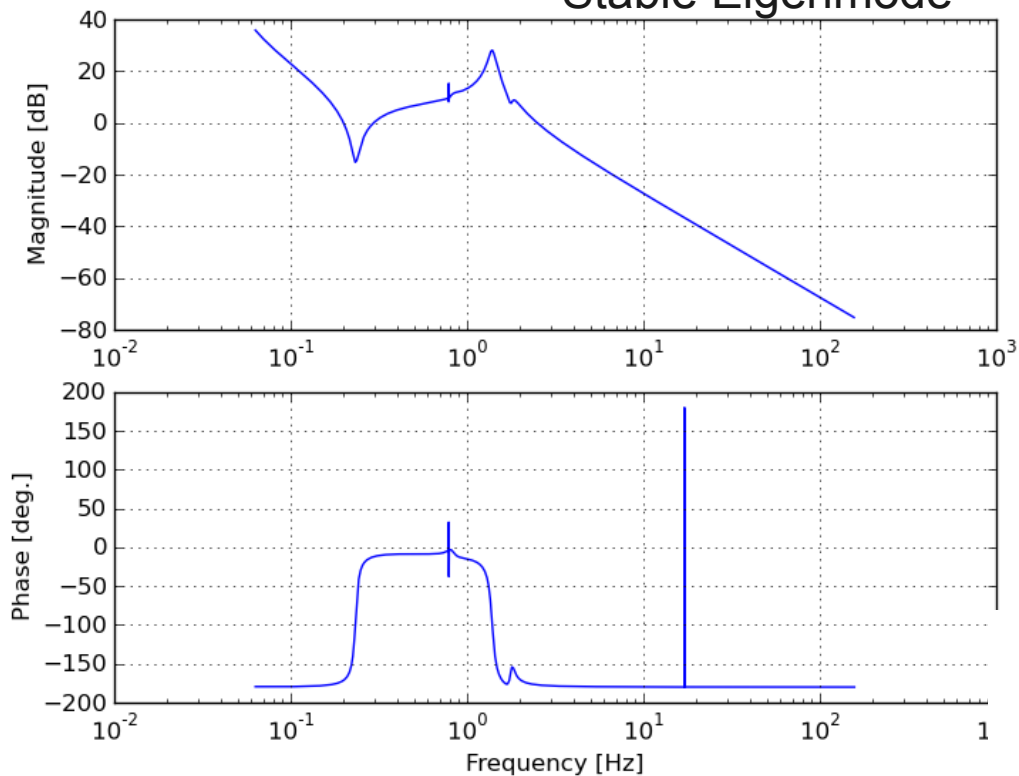

Unstable Eigenmode

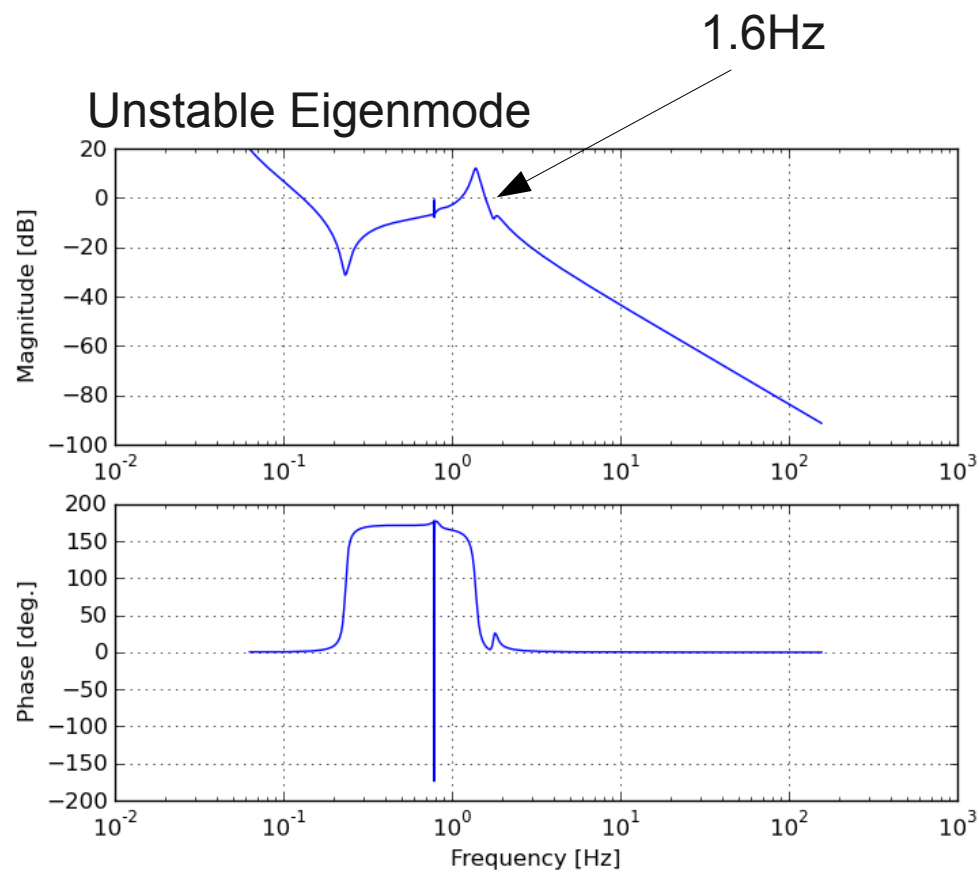

Large beam, positive ($g_1=1, g_2=0.572$)

Stable Eigenmode

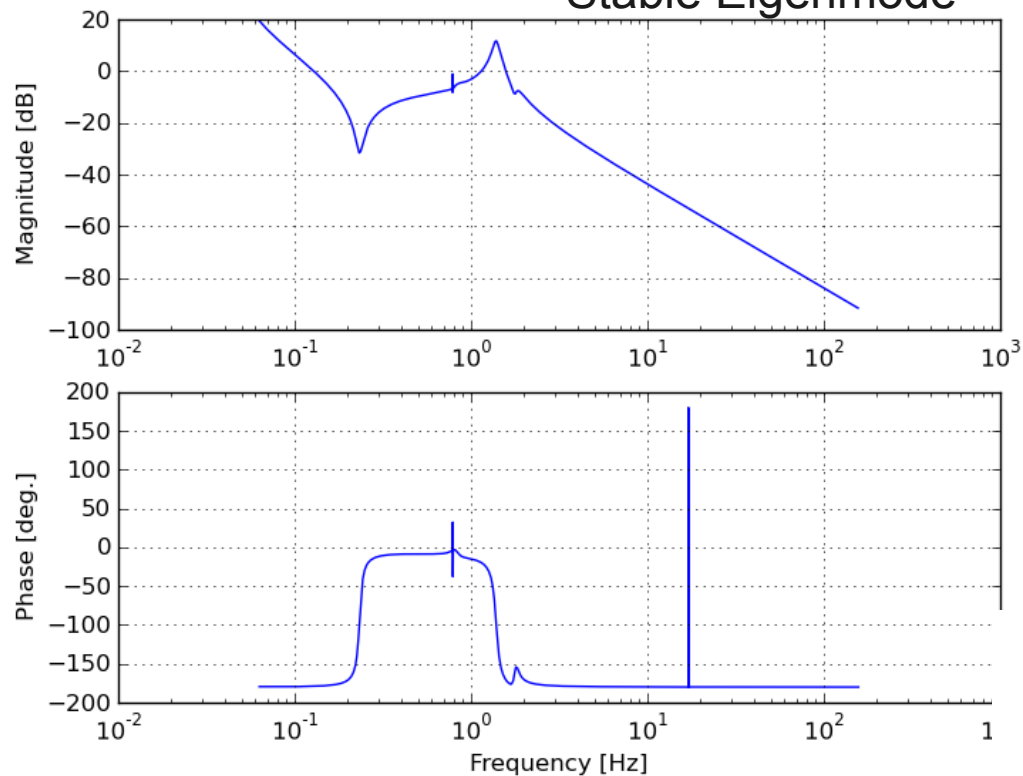

Unstable Frequency

Large Beam

$g_1 = 1, g_2 = 0.572:$ **2.65Hz**

$g_1 = -0.87, g_2 = -0.6:$ **1.6Hz**

Small Beam

$g_1 = g_2 = 0.586:$ **2.2Hz**

$g_1 = g_2 = -0.586:$ **1.6Hz**

Unstable Eigenmode

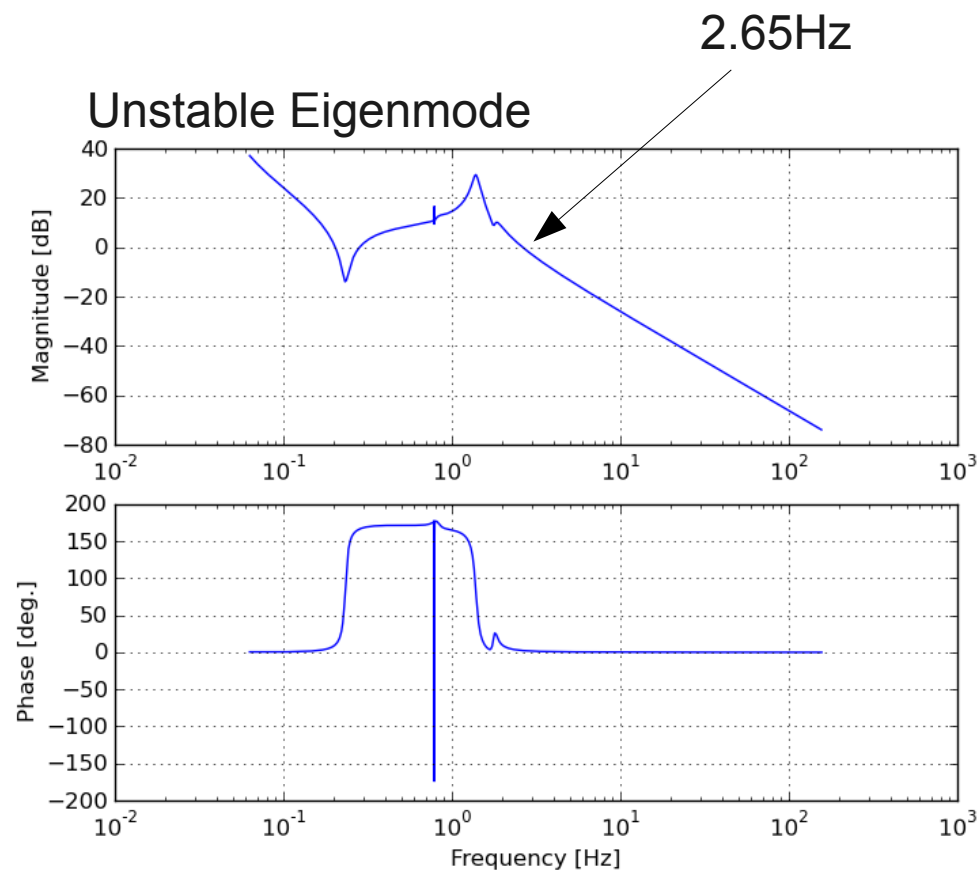

Parametric Instability

There are dangerous regions to avoid in the g-factor space

Positive g-factor

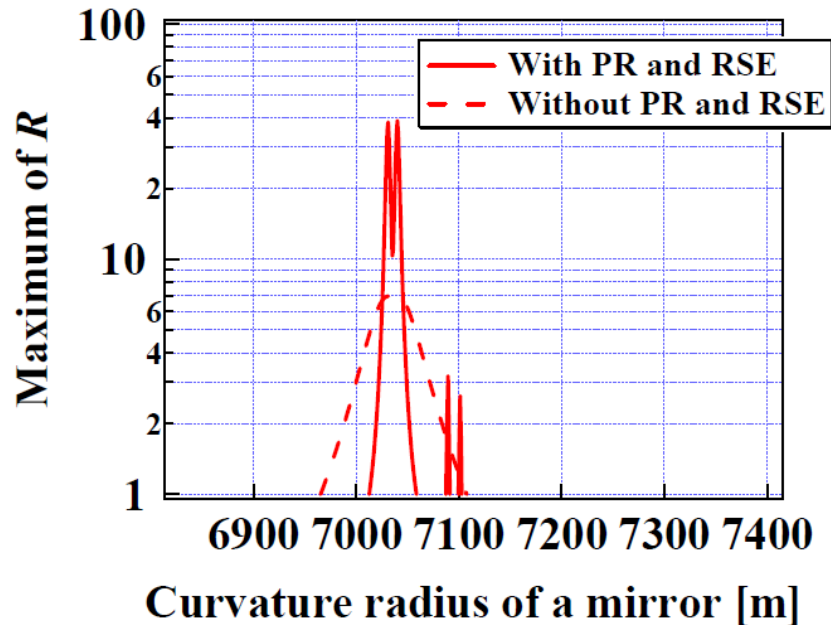

Negative g-factor

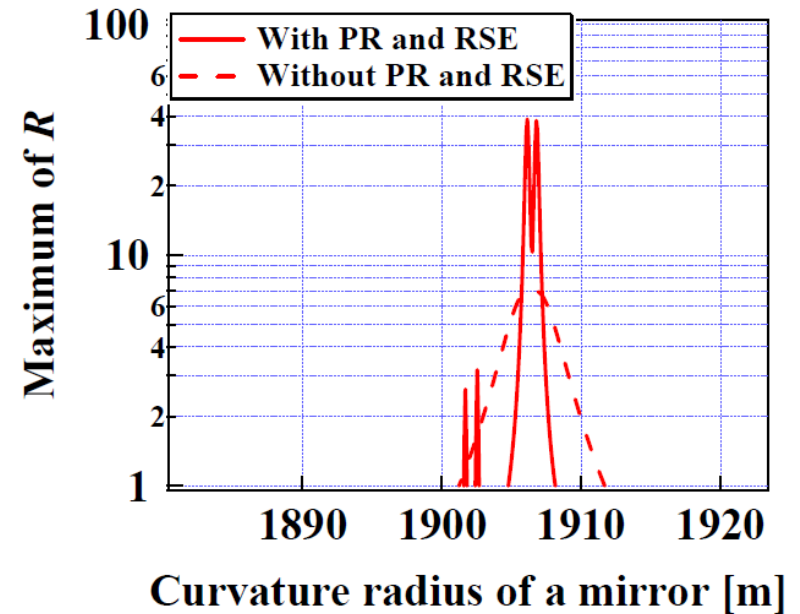

The error requirement on the mirror ROC is stricter for the negative g-factor.
by (R_p/R_n)

Negative g-factor: $R \sim 1.9\text{km}$
Positive g-factor: $R > 7\text{km}$



Negative g-factor is about 3.7 times more severe to ROC error in terms of PI

10m ROC error for 1.9km mirror -> 0.5% error
100m ROC error for 7km mirror -> 1.5% error

g-factor Comparison

		Thermal Noise (IR) DRSE/BRSE [Mpc]	Optical Spring Unstable Freq.	PI	ROC
(a)	$g_1=1$ $g_2=0.572$	275/246	2.6Hz	Easy	ITM: >100km ETM: 7000m
(b)	$g_1=-0.87$ $g_2=-0.6$	273/245	1.6Hz	Severe	ITM: 1604m ETM: 1875m
(c)	$g_1=0.586$ $g_2=0.586$	266/241	2.2Hz	Easy	ITM: 7246m ETM: 7246m
(d)	$g_1=-0.586$ $g_2=-0.586$	266/241	1.6Hz	Severe	ITM: 1892m ETM: 1892m

Arm Cavity Parameters

Length	3000.00m	ETM ROC	7000m
ITM Reflectivity	99.6%	ETM Beam Size	4.53cm
ITM ROC	flat	g-factor	0.572
ITM Beam Size	3.43cm	Round Trip Loss	<100ppm
ETM Reflectivity	>99.9945%	Finesse	1546

Higher Order Modes

- TEM00 resonance has to be isolated from higher order modes
- Higher order modes are large => Diffraction loss

Resonant curves of LG(l,m) modes

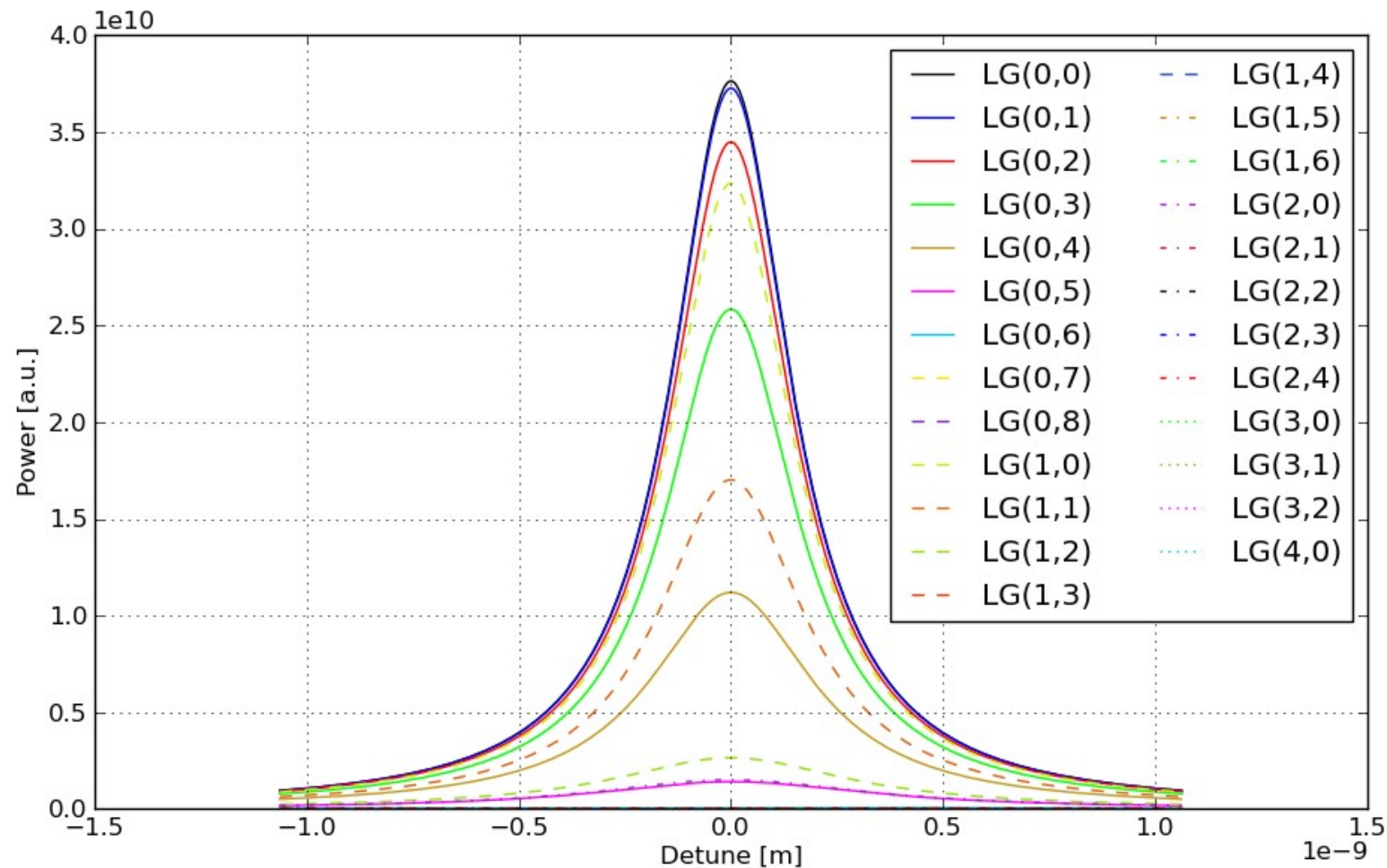

Maximum HOM Power, ITM ROC error

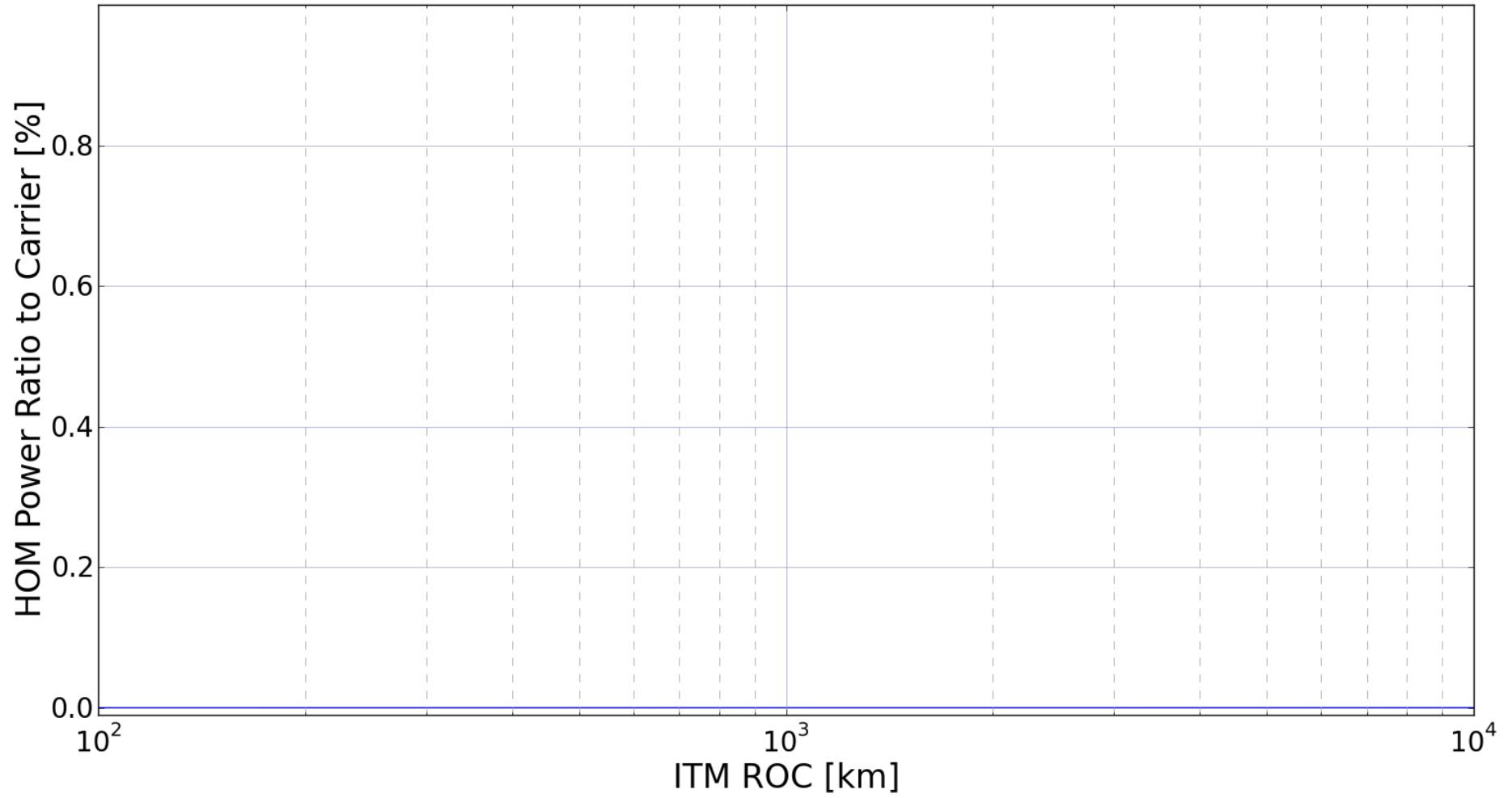

Maximum HOM Power, ETM ROC error

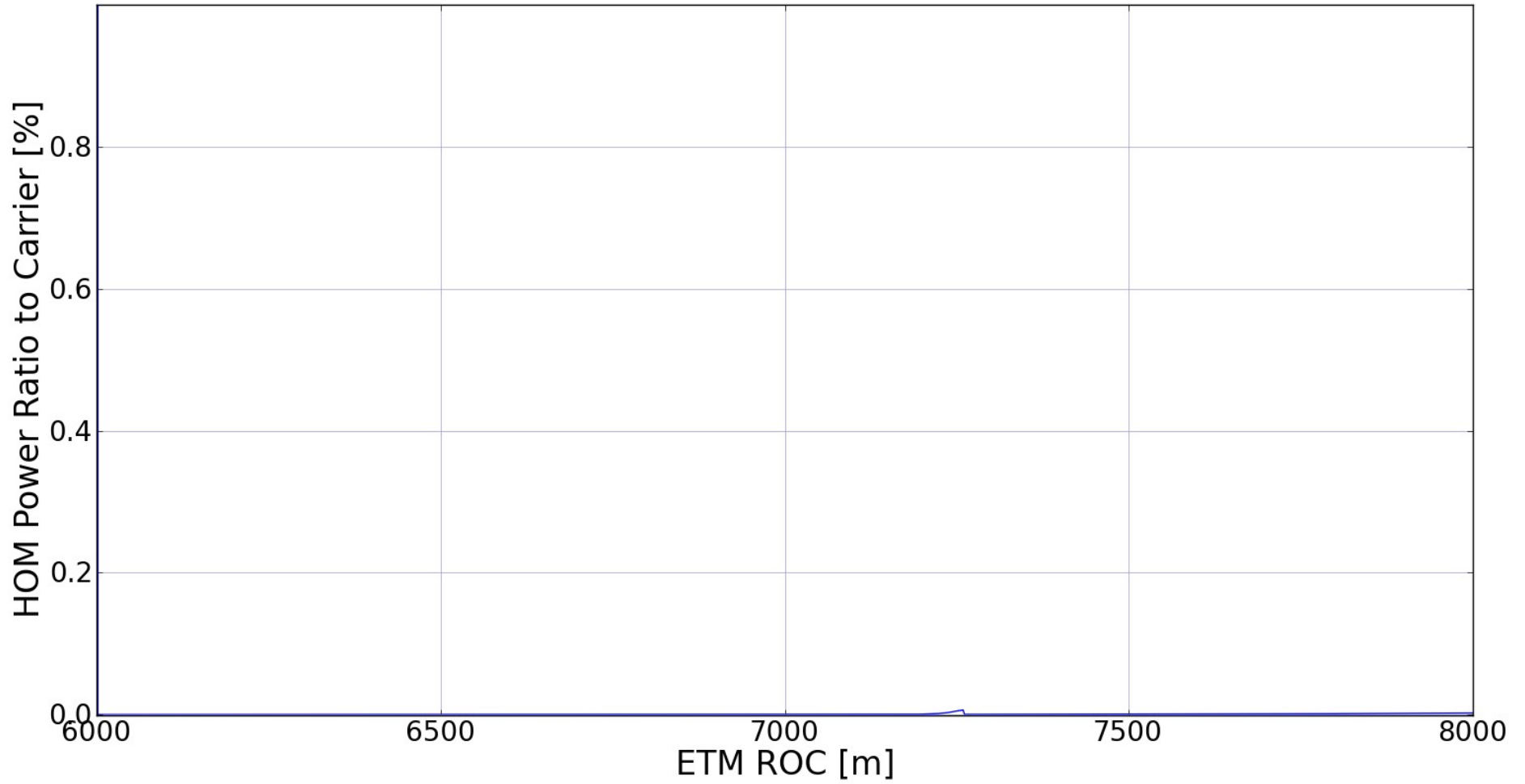

HOM RF Sideband Overlap

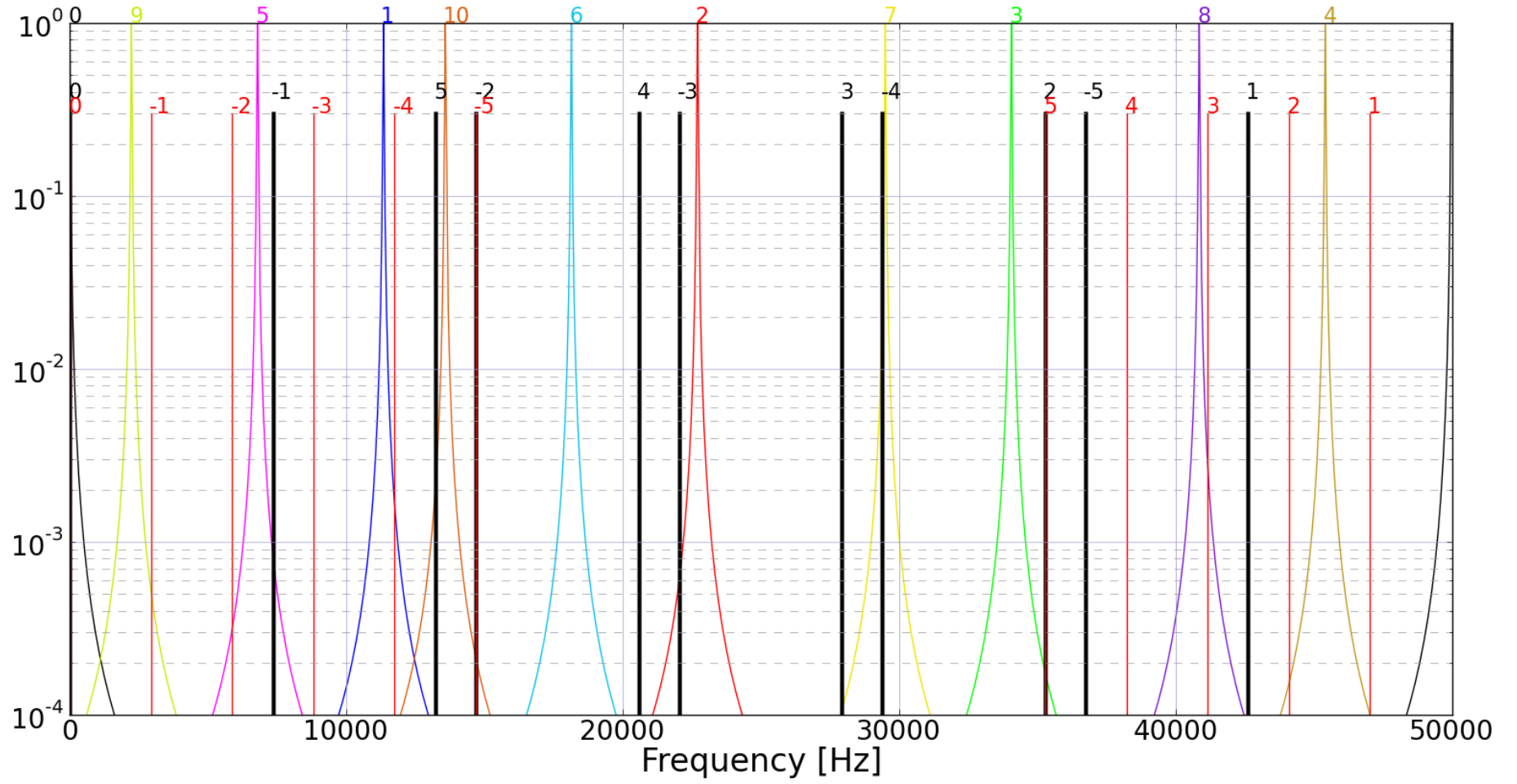

Constraints

- Resonate RF sidebands in desired parts of the interferometer
 - f1 sees both PRC and SRC
 - f2 is only resonant in PRC
- MC length must not be too long (< 30m)
- Modulation frequencies should not be too high
 - PD and QPD response
- Modulation frequencies should not be too low
 - RF laser noise, CARM UGF
- Michelson Average Length ~ 25m
 - Cryogenic radiation shield = 20m (BS <-> ITM)
 - Schnupp asymmetry
- Not too large asymmetry
- Room for Folding

RF Sideband Resonant Conditions

- f1 sideband resonates in PRC-SRC
- f2 sideband resonates only in PRC
- f3 sideband does not enter the interferometer at all

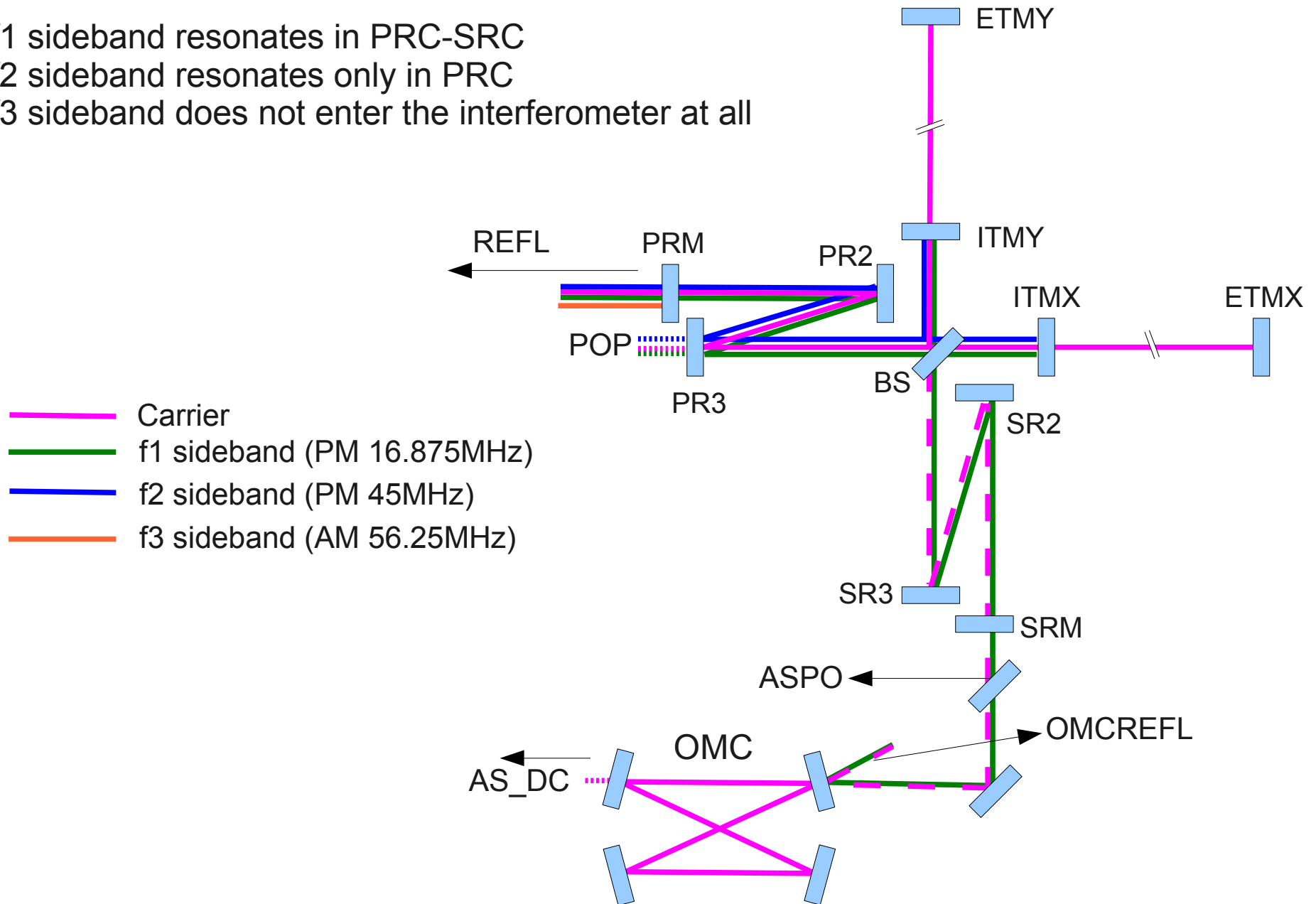

RC Length Parameter Scan

There are many candidates of Lprc, Lsrc, Las which satisfy the resonant conditions

Parameter selection procedure

- Fix f2 to be 45MHz
 - Not too high, not too low
- Choose Las
 - MICH reflectivity for f2 = 100%
 - Las = 3.3m or 6.6m
- Choose Lprc
 - Resonate f2
 - 65m < Lprc < 85m
- Choose f1
 - Integral (or half integral) multiple of the FSR of PRC
 - MC length must not be too long (GCD of f1 and f2 is large enough)
- Choose Lsrc
 - f1 is resonant in SRC <= anti-resonant in PRC
 - f1 is anti-resonant in SRC <= resonant in PRC
 - 65m < Lsrc < 85m

Still there are many candidates

- Finesse of PRC-SRC for f1 varies depending on the MICH reflectivity to f1
- Choose one with wide enough resonance to allow detuning of SRC by offset

Parameter Candidates

It is basically a matter of choosing [f1 frequency](#)

Figure of Merit

Nonlinearity=2次の係数/1次の係数

f1/f2	PRC/SRC	f1(MHz)	MC(m)	Lp(m)	Ls(m)	Is (BRSE)	Is (DRSE)	linearity (DRSE)
5/6	anti/reso	37.5	20	70	70	0.00140	0.00061	-0.63183
2/7	anti/reso	~12.9	23	70	70	0.00403	0.00182	-0.59047
3/7	anti/reso	~19.3	23	70	70	0.00839	0.00416	-0.49474
2/8	anti/reso	11.25	27*	79.9	79.9	0.00312	0.00139	-0.60448
3/8	anti/reso	16.875	27	79.9	79.9	0.00670	0.00319	-0.53623
7/8	anti/reso	39.375	27	66.6	66.6	0.00079	0.00034	-0.64081
2/9	anti/reso	10	30	89.9	89.9	0.00248	0.00109	-0.61486
4/9	anti/reso	20	30	89.9	89.9	0.00887	0.00447	-0.48042
2/10	anti/reso	9	17	83.3	83.3	0.00202	0.00088	-0.62215
3/10	anti/reso	13.5	33	66.6	66.6	0.00444	0.00202	-0.58195
4/10	anti/reso	18	17	66.6	66.6	0.00741	0.00357	-0.52424
9/10	anti/reso	40.5	33	83.3	83.3	0.00051	0.00022	-0.64465
5/6	reso/anti	37.5	20	60	60	0.00370	0.00360	-0.01577
6/7	reso/anti	~38.6	23	70	70	0.00279	0.00275	-0.00785
2/8	reso/anti	11.25	27*	73.3	73.3	0.00739	0.00644	-0.07847
3/8	reso/anti	16.875	27	66.6	66.6	0.01143	0.00757	-0.25657
7/8	reso/anti	39.375	27	79.9	79.9	0.00216	0.00215	-0.00386
8/9	reso/anti	40	30	60	60	0.00173	0.00173	-0.00172
3/10	reso/anti	13.5	33	83.3	83.3	0.00950	0.00744	-0.14314
9/10	reso/anti	40.5	33	66.6	66.6	0.00141	0.00141	-0.00046
5/6	reso/reso	37.5	20	60	70	0.00133	0.00133	-0.00017
7/8	reso/reso	39.375	27	79.9	66.6	0.00233	0.00231	-0.00479
9/10	reso/reso	40.5	33	66.6	83.3	0.00350	0.00342	-0.01388

Final Candidates

	9MHz	11.25MHz	16.875MHz
Lprc	74.95m	73.28m	66.62m
Lsrc	74.95m	73.28m	66.62m
Las	6.66m	3.33m	3.33m
Lmc	33.3m	26.65m	26.65m
f3	13.5MHz($f_2 \cdot 3/10$)	61.9MHz($f_2 \cdot 11/8$)	56.3MHz ($f_2 \cdot 10/8$)
DDM freq.	22.5MHz, 31.5MHz	16.9MHz, 50.6MHz	11.25MHz, 39.4MHz

Pros and Cons

- Loop noise 11.25MHz < 16.875MHz < 9MHz (worse < better)
- 9MHz needs a bit longer MC (33m not 27m)
- 9MHz has a longer asymmetry (6.6m compared to 3.3m)
- 11.25MHz is incompatible with 3rd harmonics demodulation
- 9MHz and 16.875MHz have larger SRCL non-linearity

Signal Extraction Ports

- f1 sideband resonates in PRC-SRC
- f2 sideband resonates only in PRC
- f3 sideband does not enter the interferometer at all

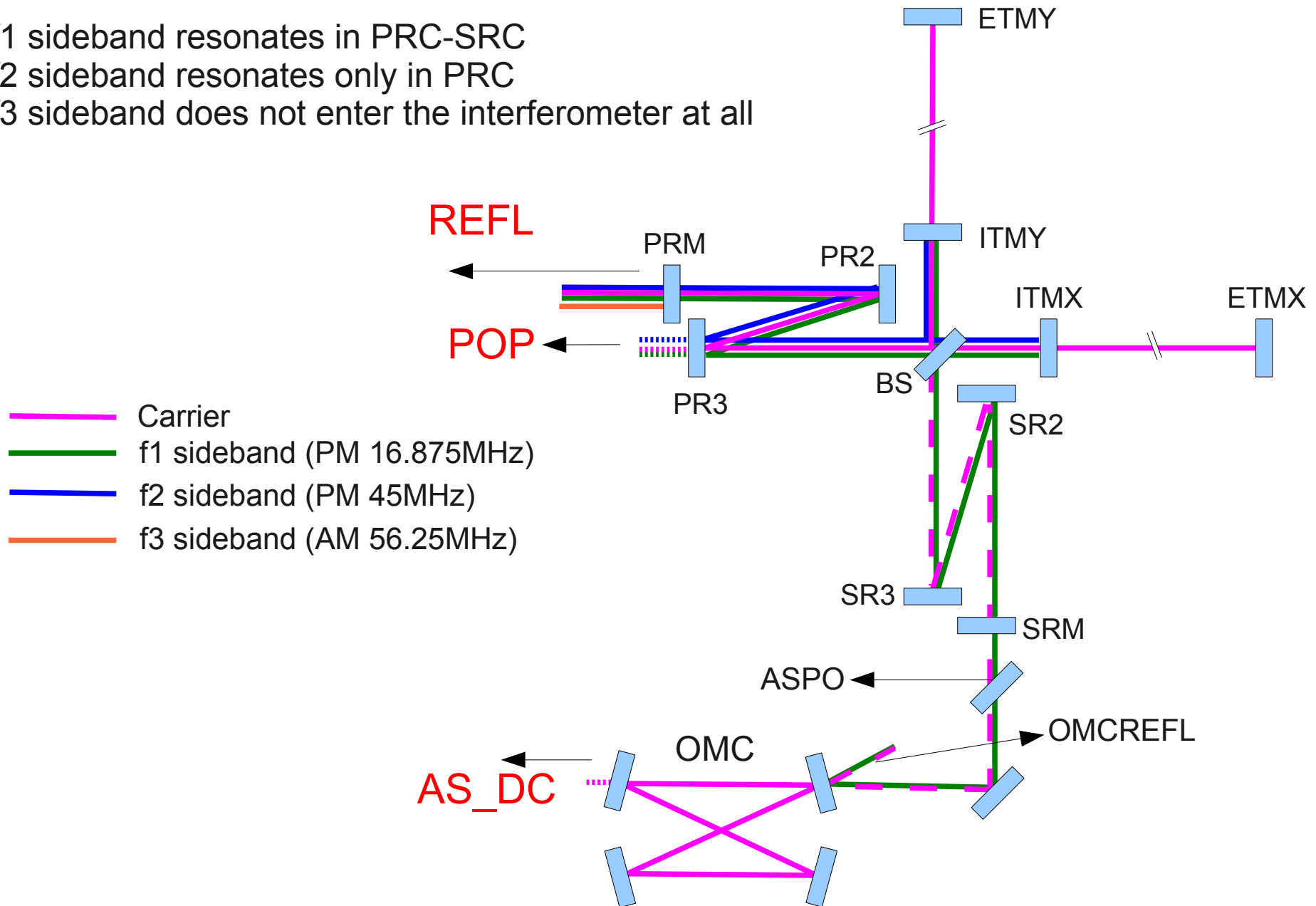

Modulation Types

PM or AM ?

- AM wastes laser power
 - Low loss method exist [N. Ohmae, Opt. Lett.]
---> complicated
- Mach-Zhender may introduce extra noise.

Conventional Scheme

f1:PM, f2:PM

- No MZ
- No AM

Conventional Scheme + NRS

f1:PM, f2:PM, f3:AM

- May need MZ
- Need AM
- AM can be weak if used only for lock acquisition

AM-PM Scheme

f1: AM, f2:PM

- Need MZ
- Need AM
- May have a problem with WFS at AS

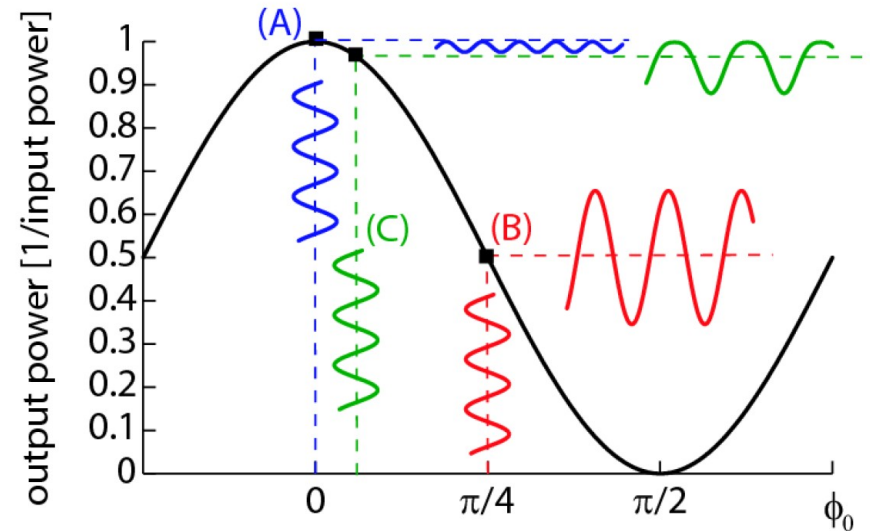

Default:

Conventional Scheme + (NRS)

Signal Ports and Naming Convention

How to decipher a signal name ?

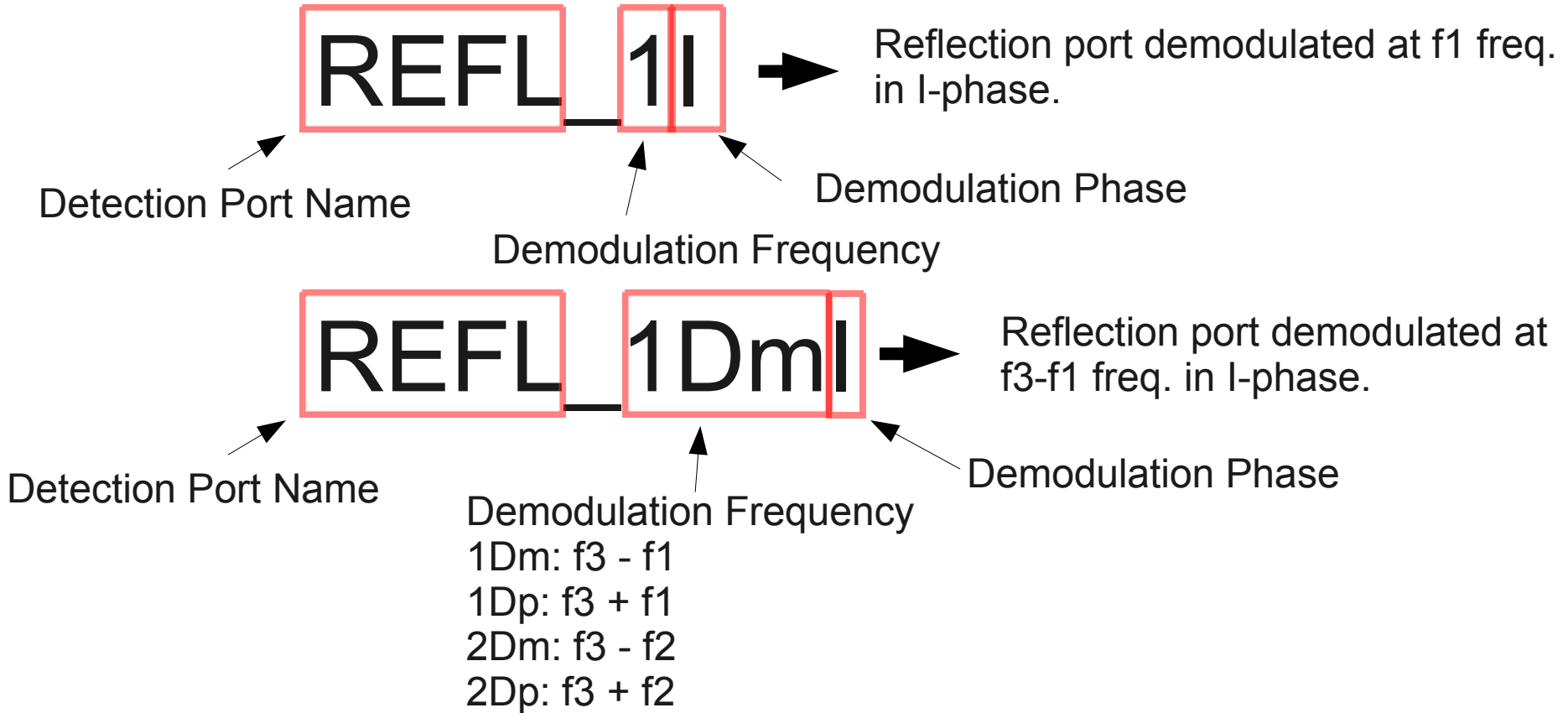

DC Power at PDs

Attenuated to be less than 100mW on each PD

Sensing Matrix

BRSE: 16.875MHz - 45MHz

	DARM	CARM	MICH	PRCL	SRCL
AS_DC	1	4.2e-5	1.0e-3	4.8e-6	4.7e-6
REFL_1I	5.4e-3	1	4.3e-5	6.5e-3	4.3e-3
REFL_1Q	5.0e-3	1.3e-2	1	1.02	0.67
POP_2I	2.3e-2	4.3	1.0e-2	1	2.5e-4
POP_1I	8.7e-2	16.23	3.1e-2	2.1	1

- Large Coupling from CARM to PRCL & SRCL
- Gain hierarchy to suppress CARM
- PRCL, SRCL mixed to MICH

Sensing Matrix

Use of Non-Resonant Sideband (f3: 56.25MHz)

BRSE: 16.875MHz - 45MHz

	DARM	CARM	MICH	PRCL	SRCL
AS_DC	1	4.1e-5	1.0e-3	4.8e-6	4.7e-6
REFL_1I	5.4e-3	1	3.9e-5	5.4e-3	4.5e-3
REFL_1DmQ	4.8e-3	2.5e-3	1	0.7	1.3
REFL_2Dml	2.3e-2	8.3e-2	0.18	1	0.32
REFL_1Dml	8.7e-2	1.5e-2	2.4e-2	1.7	1

- CARM coupling is now small
- Shot noise may not be so good.

Loop Noise Coupling

Formulation used here:

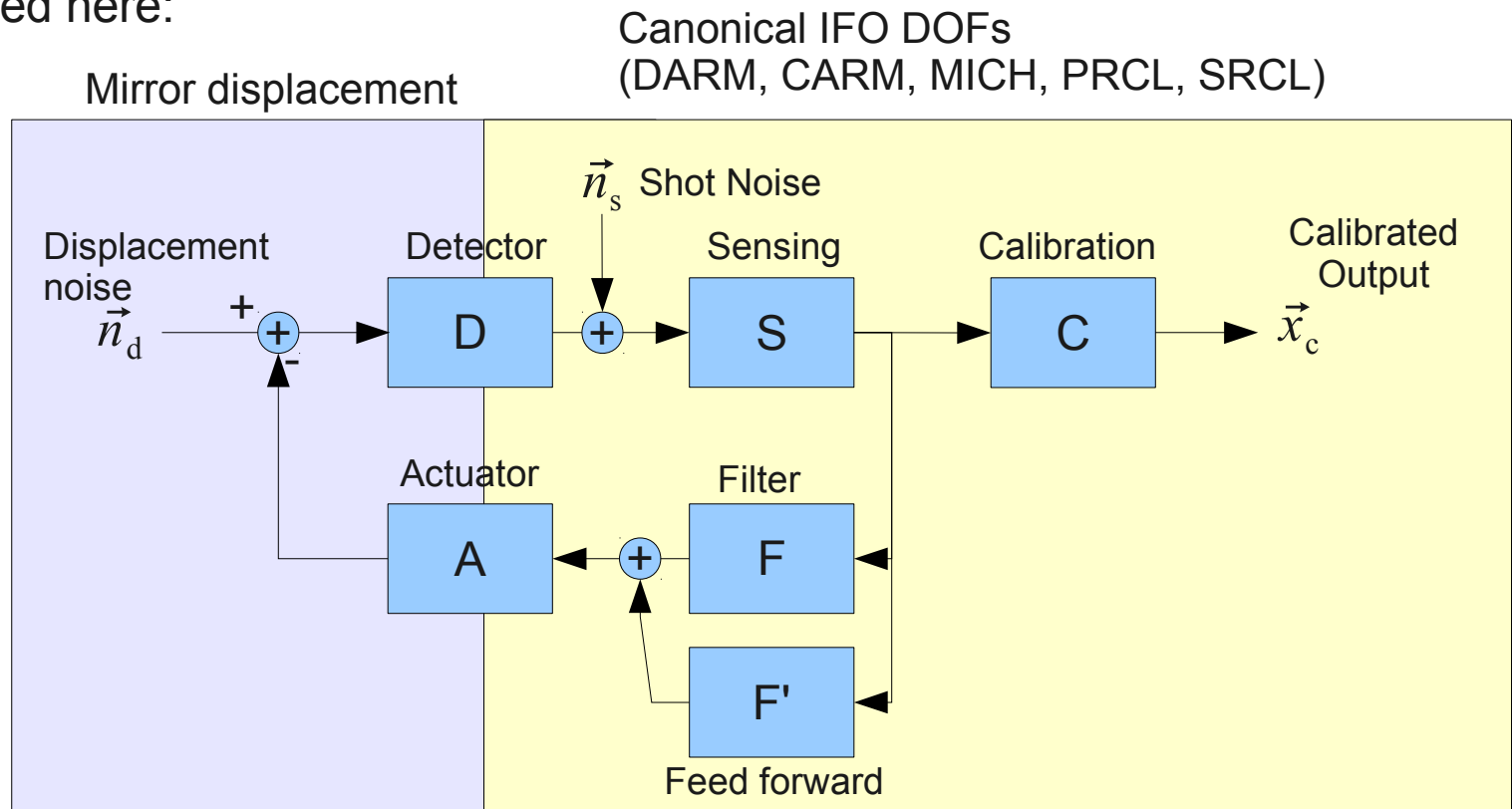

$$\vec{x}_c = (I + G)^{-1} \cdot S \cdot \vec{n}_s + (I + G)^{-1} \cdot SD \cdot \vec{n}_d$$

$$G \equiv S \cdot D \cdot A \cdot (F + F')$$

D: Optical Gain Transfer Function calculated by Optickle

A: Mechanical TFs of the mirror suspensions + optical spring stiffness

F: Feedback filters

F': Feed forward matrix

S: Sensing matrix (here I just used identity matrix)

Loop Noise Coupling

Formulation used here:

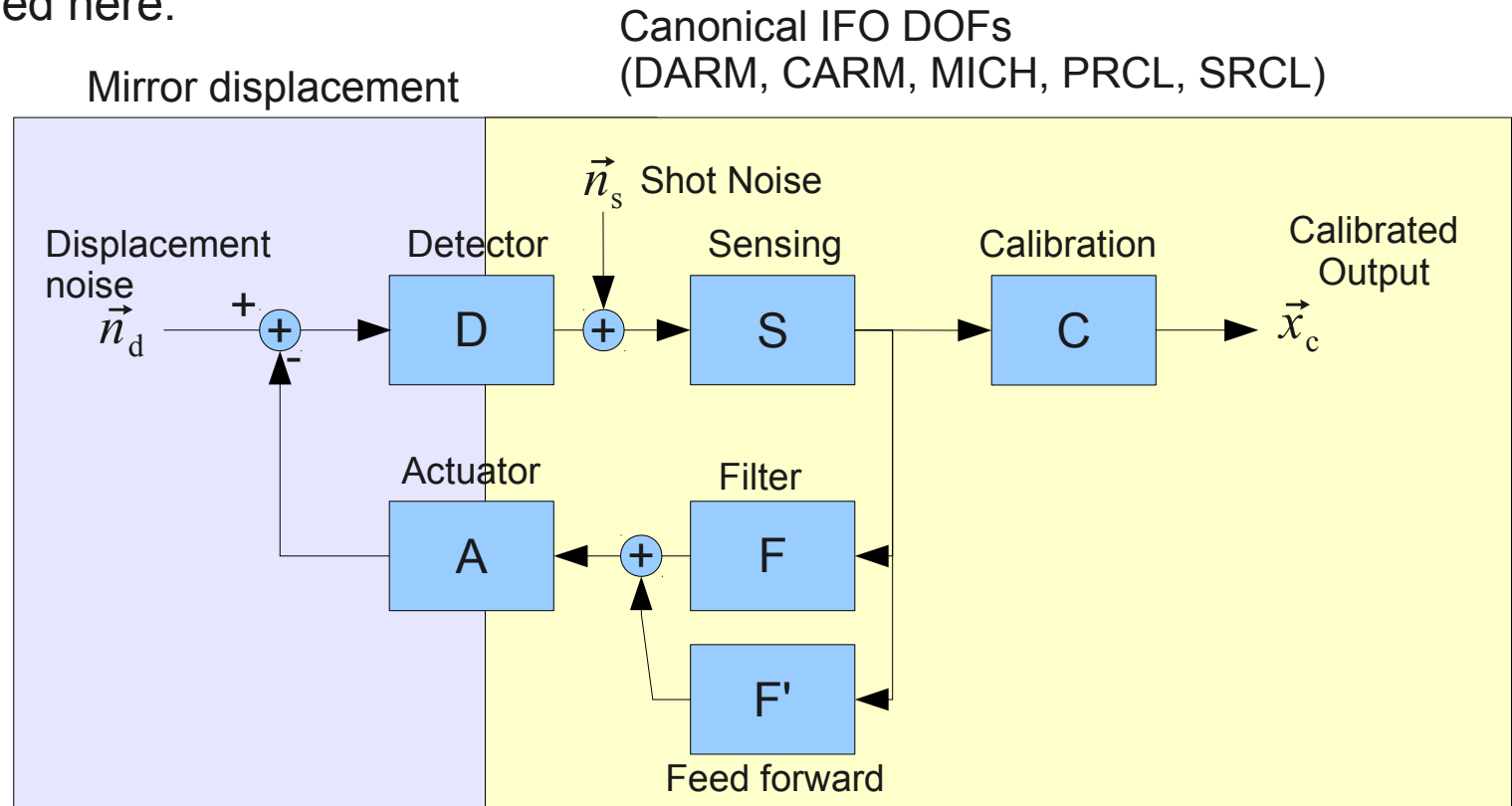

$$\vec{x}_c = (I + G)^{-1} \cdot S \cdot \vec{n}_s + (I + G)^{-1} \cdot SD \cdot \vec{n}_d$$

$$G \equiv S \cdot D \cdot A \cdot (F + F')$$

- Ideally, G is diagonal ($D \cdot A$ is diagonal), but in practice it is not.
- Off diagonal elements of G introduce the shot noise of auxiliary DOFs to DARM
- F' is added to diagonalize G (Feed forward)

Control Loop Gains

UGFs

	BRSE	DRSE
DARM	200Hz	200Hz
CARM	10kHz	10kHz
MICH	50Hz	10Hz
PRCL	50Hz	50Hz
SRCL	50Hz	50Hz

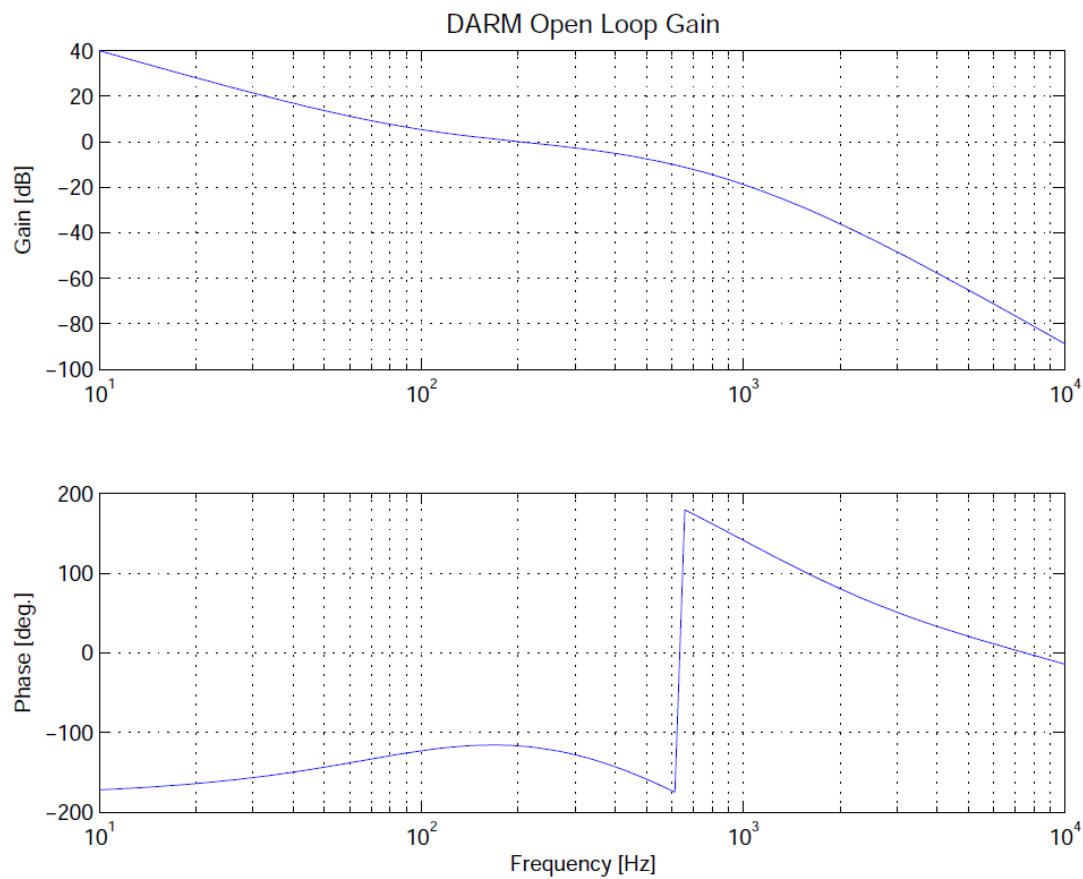

BRSE: f1=9MHz, Feed forward gain=100

DARM: ASDC
CARM: REFL 1I
MICH: REFL 1Q
PRCL: POP 2I
SRCL: POP 1I

Shot Noise Coupling with Feed Forward

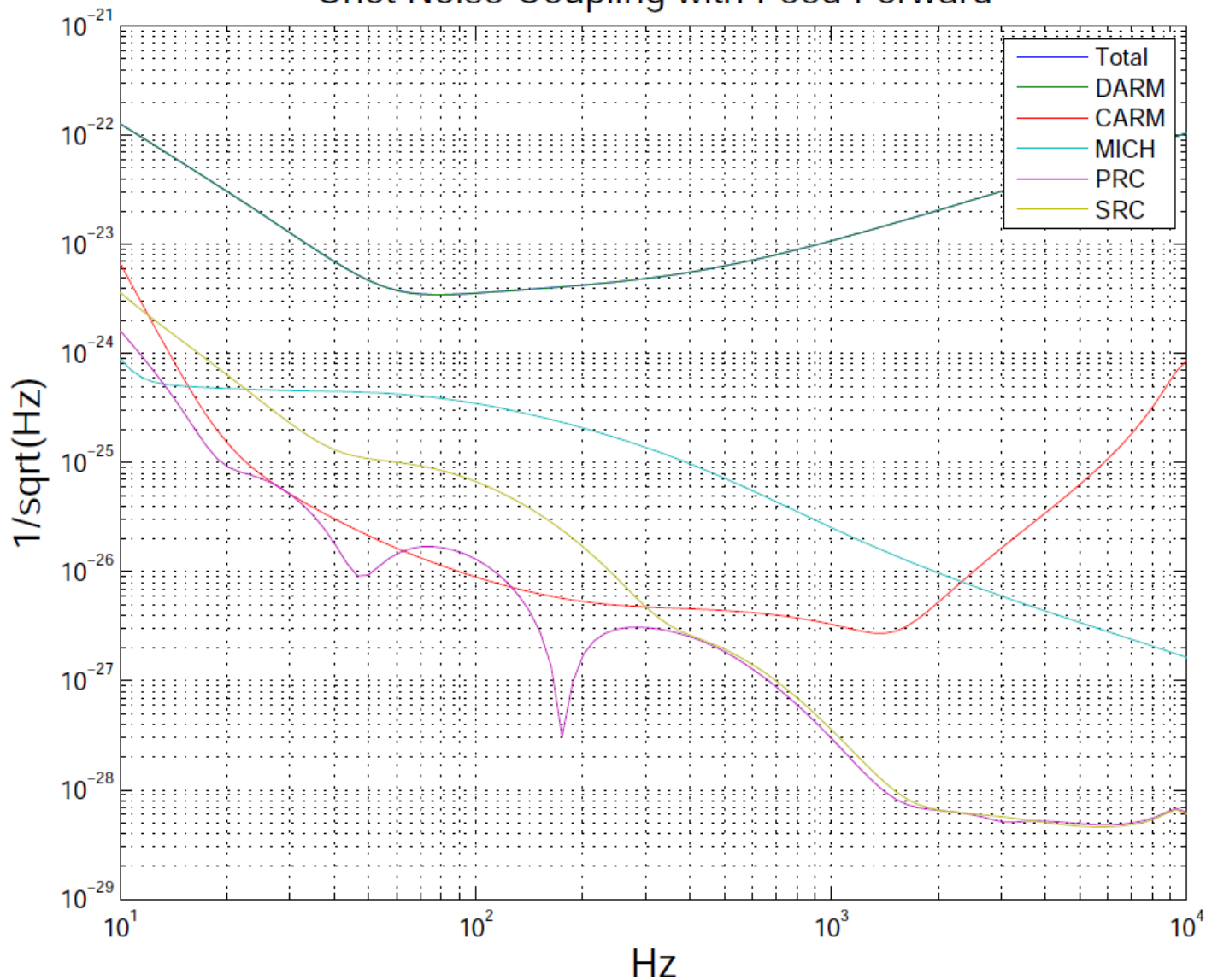

DARM: ASDC
CARM: REFL 1I
MICH: REFL 1Q
PRCL: POP 2I
SRCL: POP 1I

DRSE: f1=9MHz, Feed forward gain=100

Shot Noise Coupling with Feed Forward

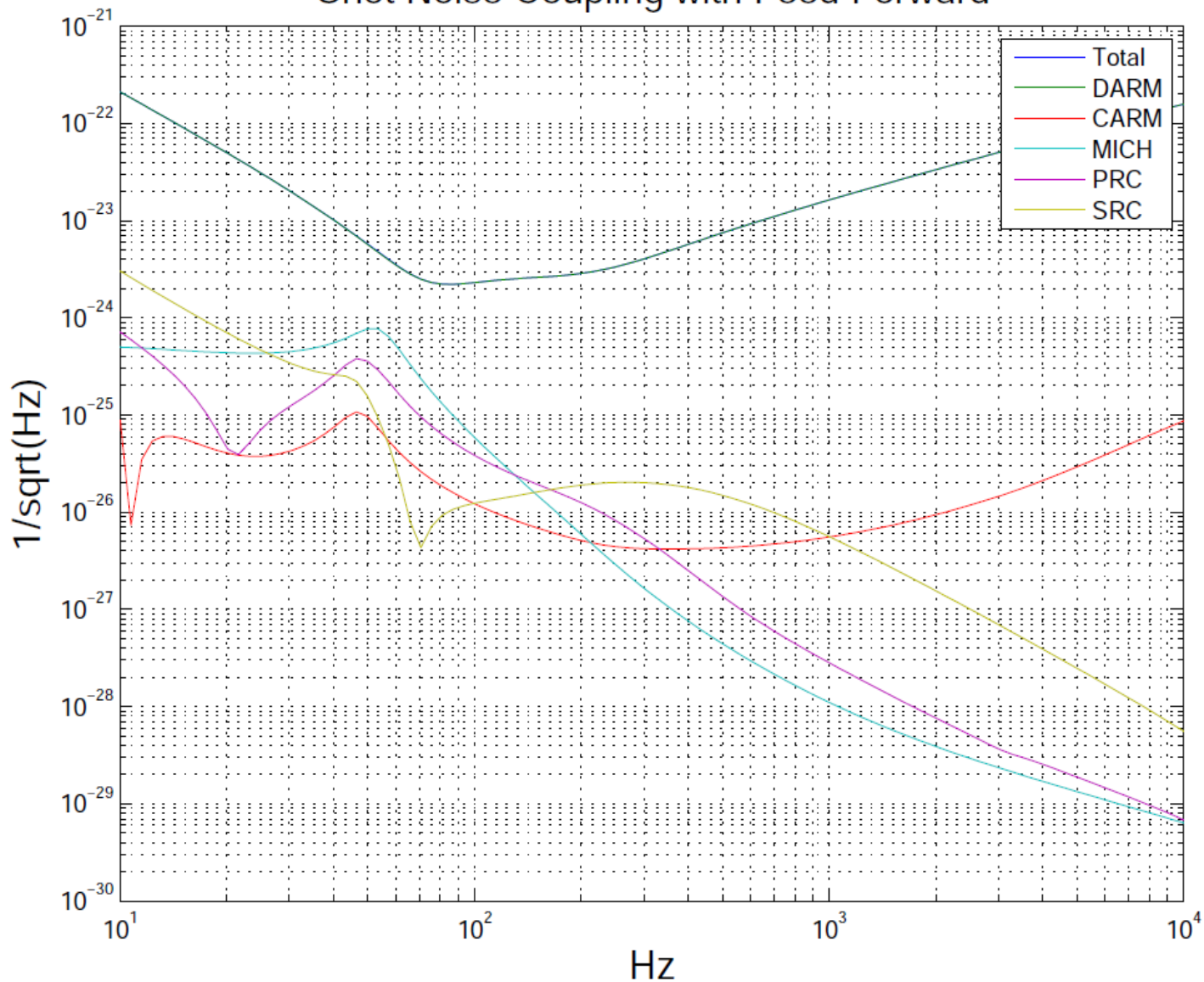

11.25MHz-45MHz

DARM: ASDC
CARM: REFL 1I
MICH: REFL 1Q
PRCL: POP 2I
SRCL: POP 1I

BRSE: f1=11.25MHz, Feed forward gain=100

Shot Noise Coupling with Feed Forward

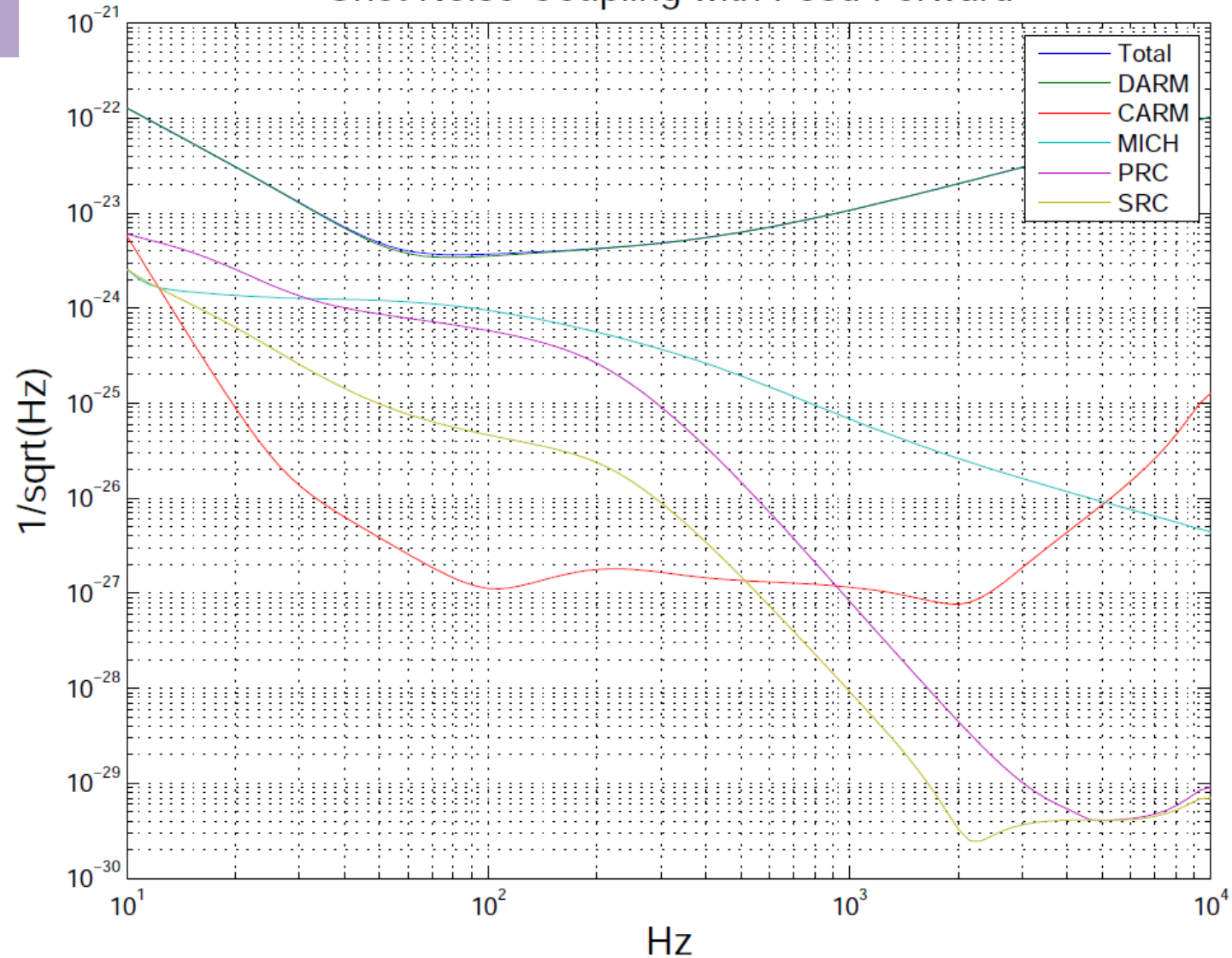

DARM: ASDC
CARM: REFL 1I
MICH: REFL 1Q
PRCL: POP 2I
SRCL: POP 1I

DRSE: f1=11.25MHz, Feed forward gain=100

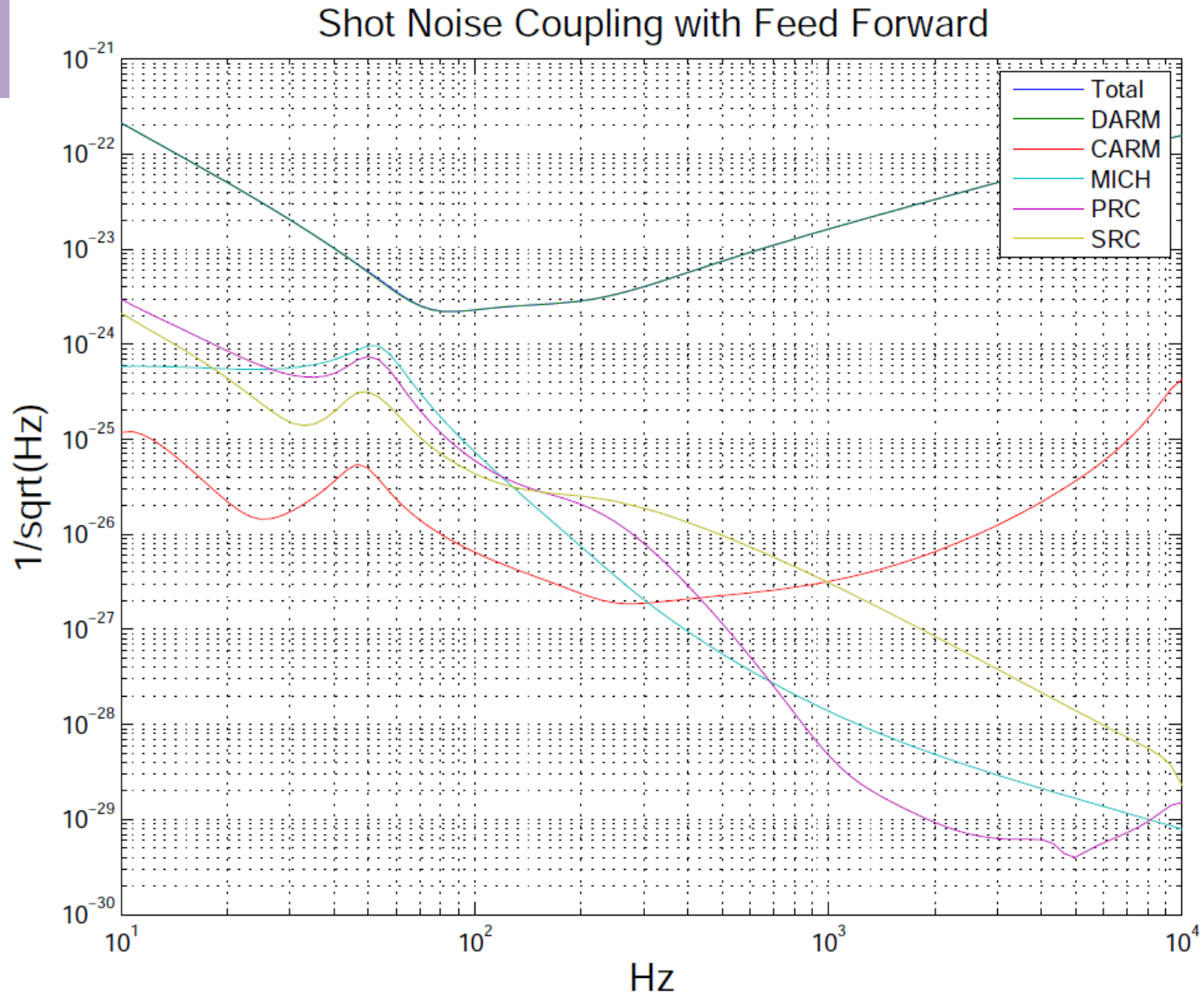

16.875MHz-45MHz

DARM: ASDC
CARM: REFL 1I
MICH: REFL 1Q
PRCL: POP 2I
SRCL: POP 1I

BRSE: $f_1=16.875\text{MHz}$, Feed forward gain=100

Shot Noise Coupling with Feed Forward

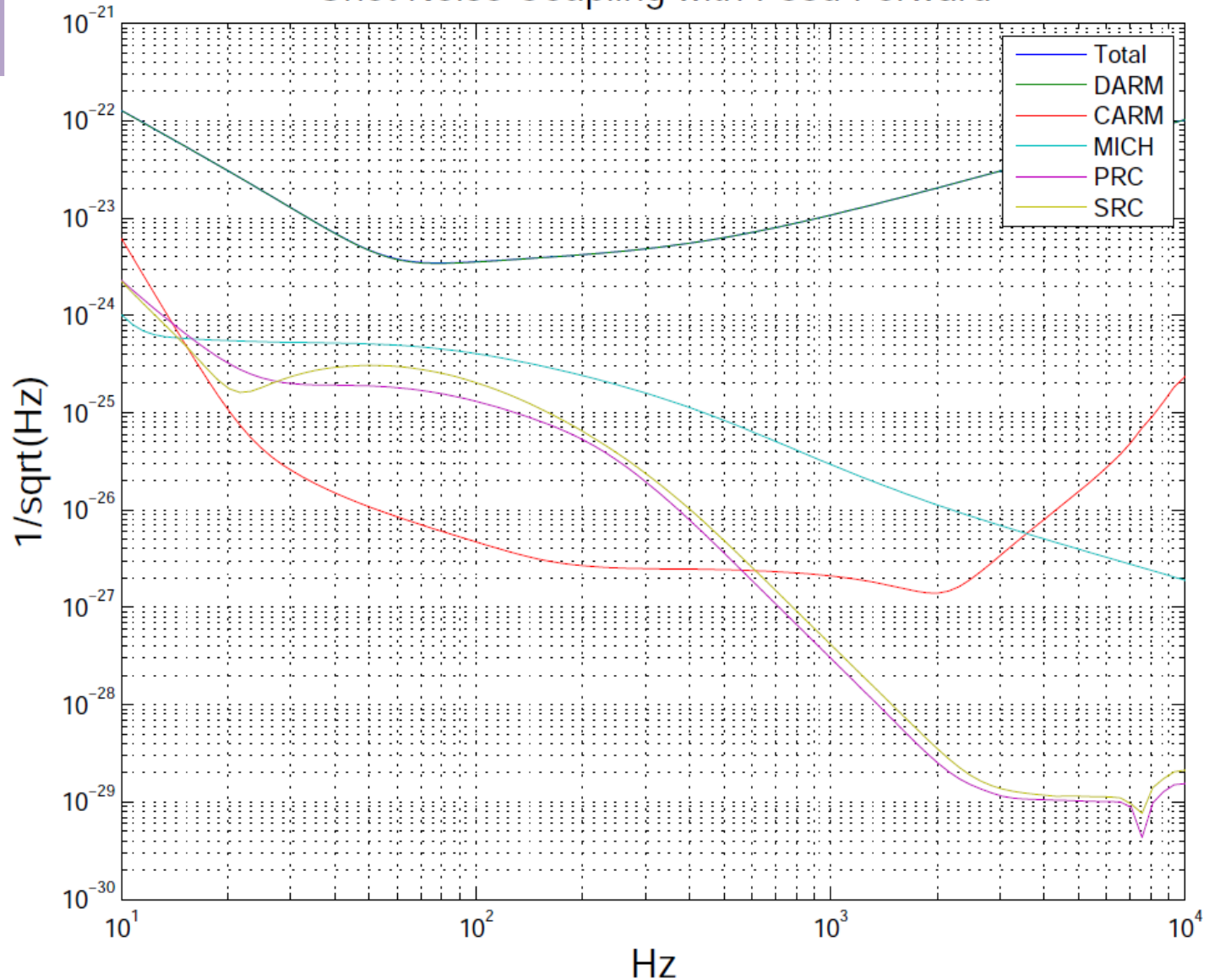

DARM: ASDC
CARM: REFL 1I
MICH: REFL 1Q
PRCL: POP 2I
SRCL: POP 1I

DRSE: f1=16.875MHz, Feed forward gain=100

Shot Noise Coupling with Feed Forward

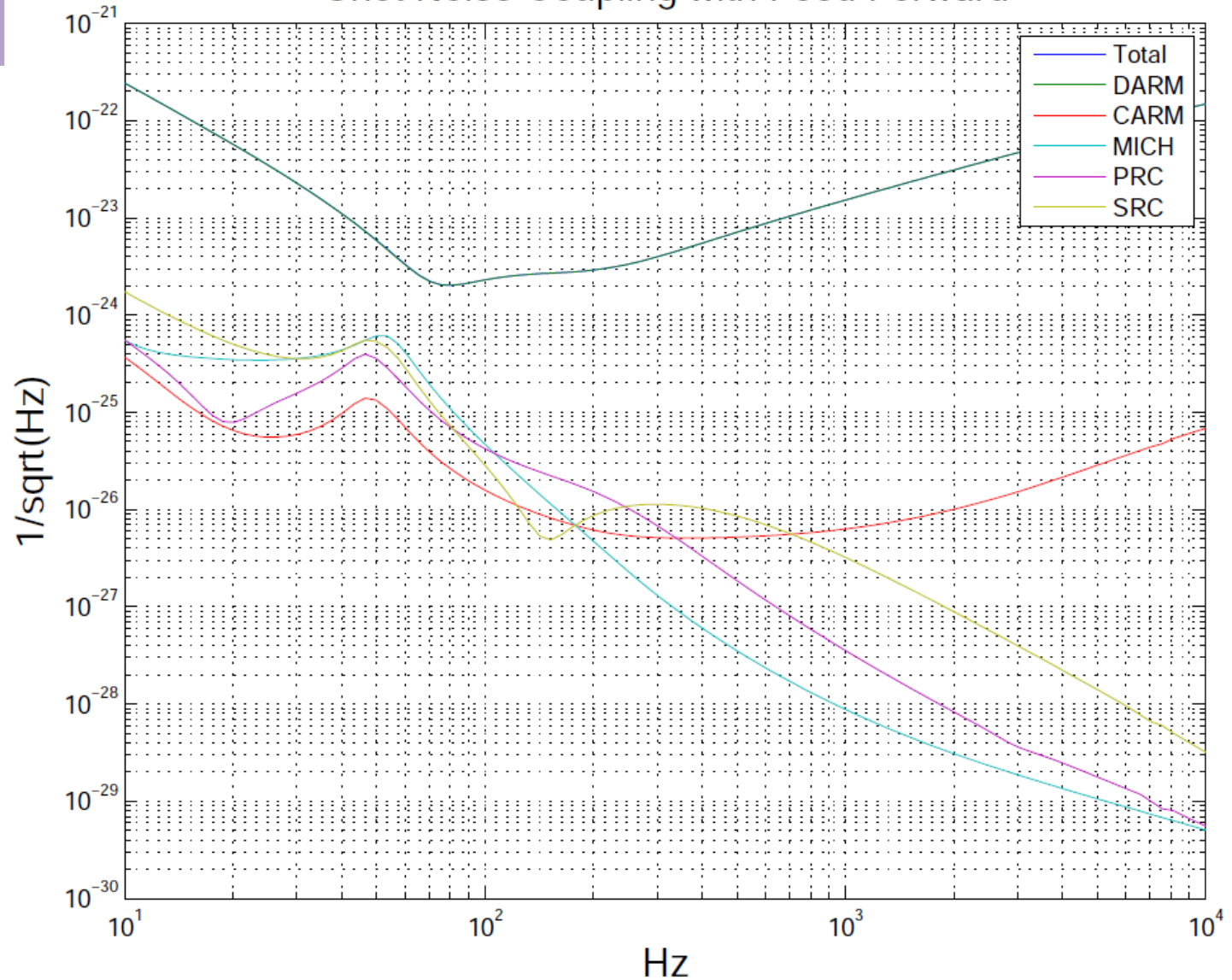

Double Demodulation with Non-Resonant Sideband

BRSE: $f_1=16.875\text{MHz}$, Feed forward gain=100

DARM: ASDC
CARM: REFL 1I
MICH: REFL 1DmQ
PRCL: REFL 2Dml
SRCL: REFL 1Dml

Shot Noise Coupling with Feed Forward

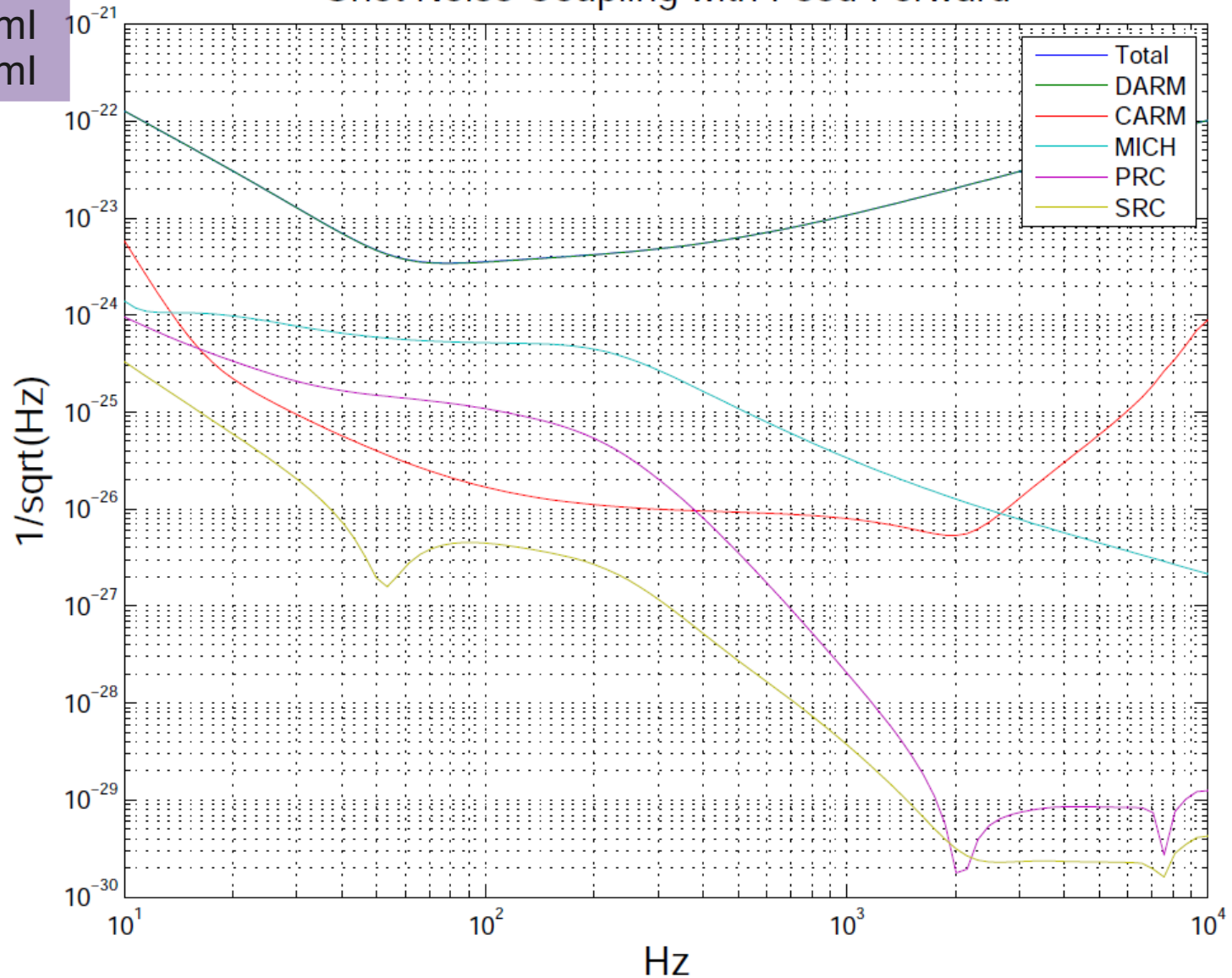

Double Demodulation with Non-Resonant Sideband

DRSE: $f_1=16.875\text{MHz}$, Feed forward gain=100

DARM: ASDC
CARM: REFL 1I
MICH: REFL 1DmQ
PRCL: REFL 2Dml
SRCL: REFL 1Dml

Shot Noise Coupling with Feed Forward

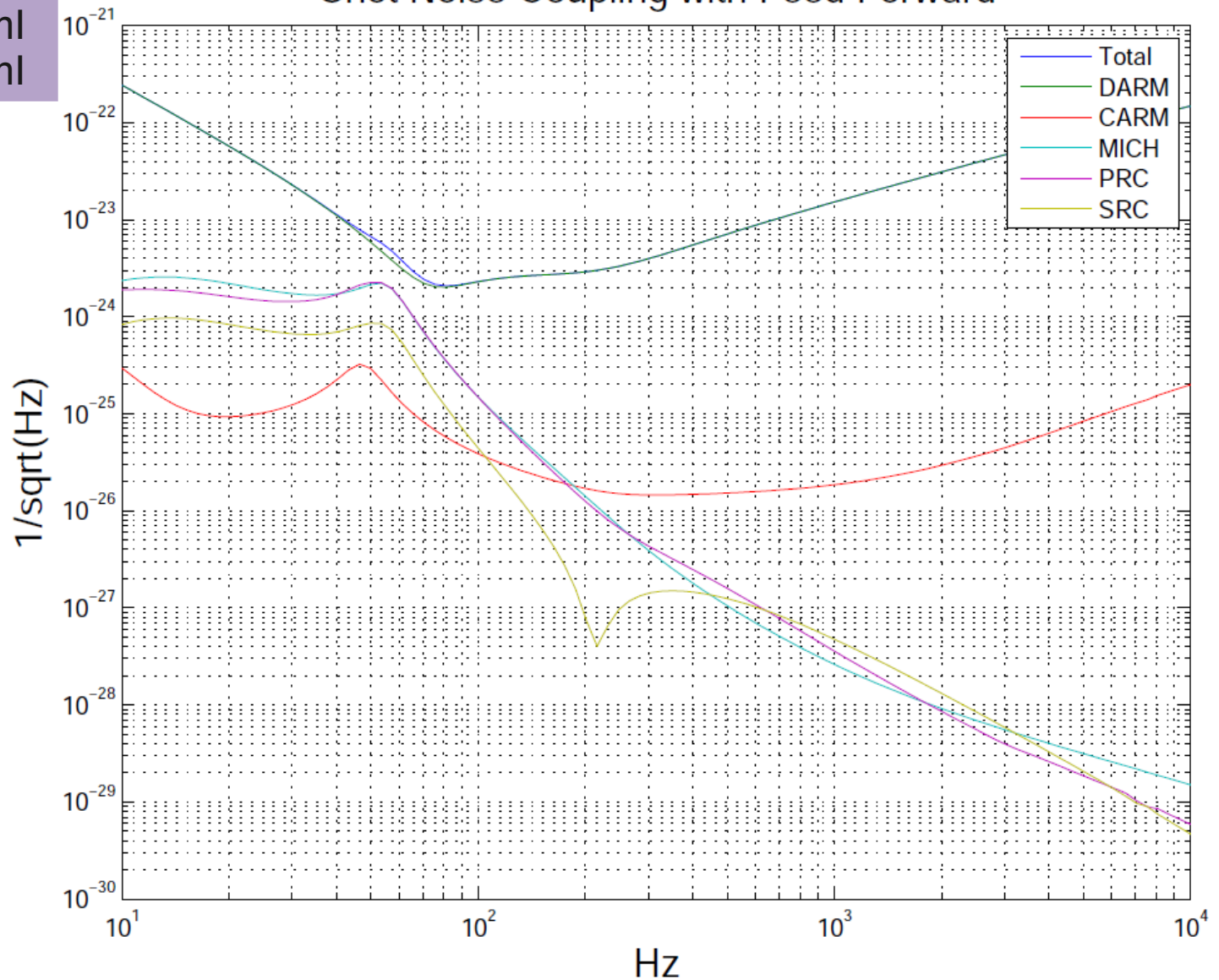

SRCL Non-Linearity

- SRC detuning by offset => Error signal non-linearity
- Up conversion noise

Formalization

$$y(t) = a x(t) + b x^2(t)$$

x: mirror displacement [m]
y: error signal [W]

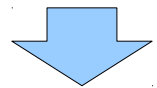

Calibration

$$x_e(t) = y(t)/a = x(t) + \underbrace{(b/a) x^2(t)}_{\text{Non-linear part}}$$

x_e : Displacement equivalent error signal [m]
b/a: dimension is 1/m

Total frequency conversion noise [ref. Applied Electronics, Koichi Shimoda]

$$P_{\text{conv}}(\omega) = \left(\frac{b}{a}\right)^2 \left[\underbrace{\int_0^{\omega} P(\omega - \omega') P(\omega') d\omega'}_{\text{Up Conversion}} + \underbrace{\int_{\omega}^{\infty} P(\omega + \omega') P(\omega') d\omega'}_{\text{Down Conversion}} \right]$$

$P(\omega)$: Displacement equivalent noise spectrum [m^2/Hz], one sided.

SRCL error signal range, f1=9MHz

$b/a = 1.3e8 \text{ m}^{-1}$

f1=9MHz

SRCL Sweep

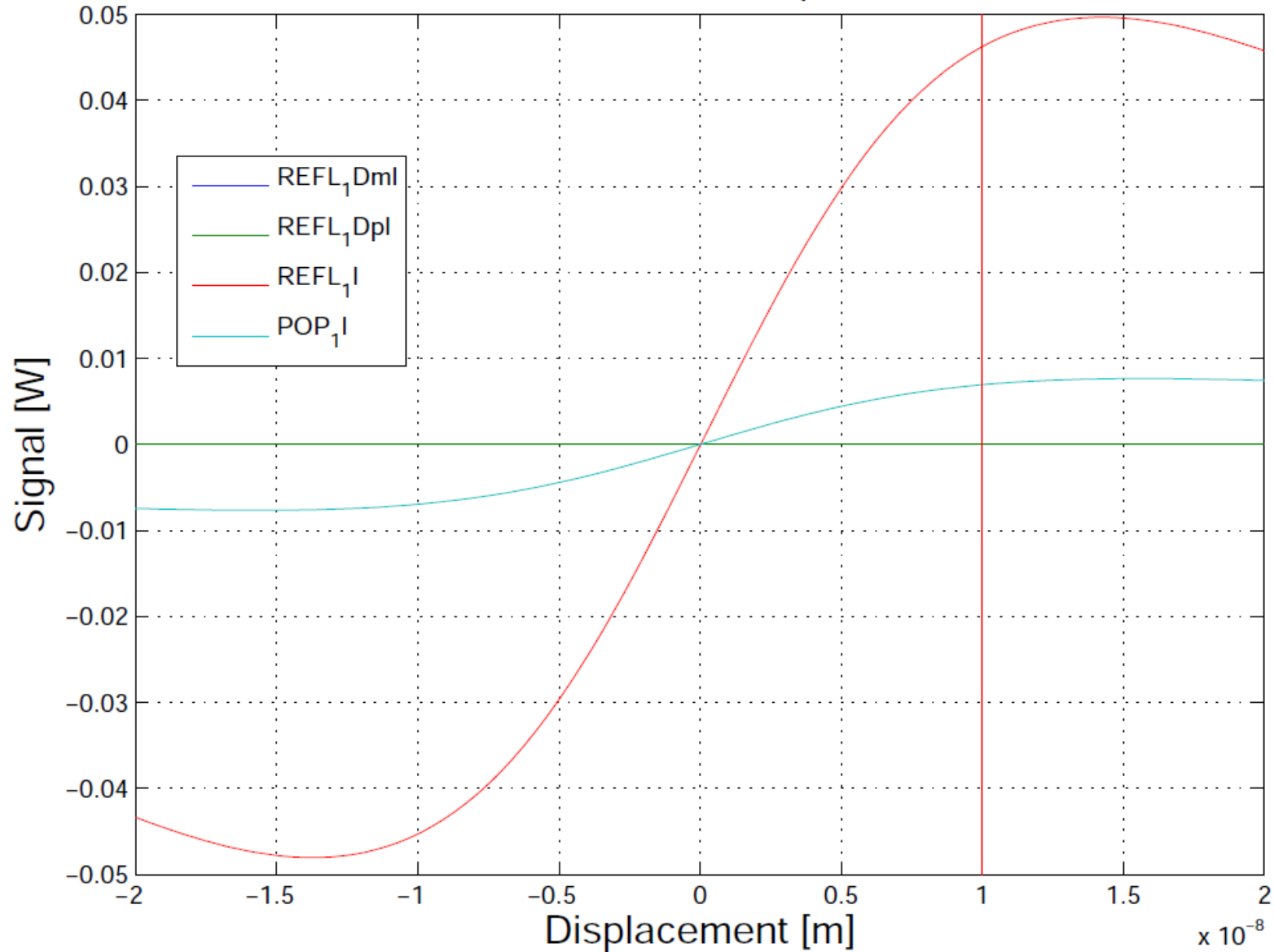

SRCL error signal range, $f_1=11.25\text{MHz}$

$$b/a = 2.7e7 \text{ m}^{-1}$$

$f_1=11.25\text{MHz}$

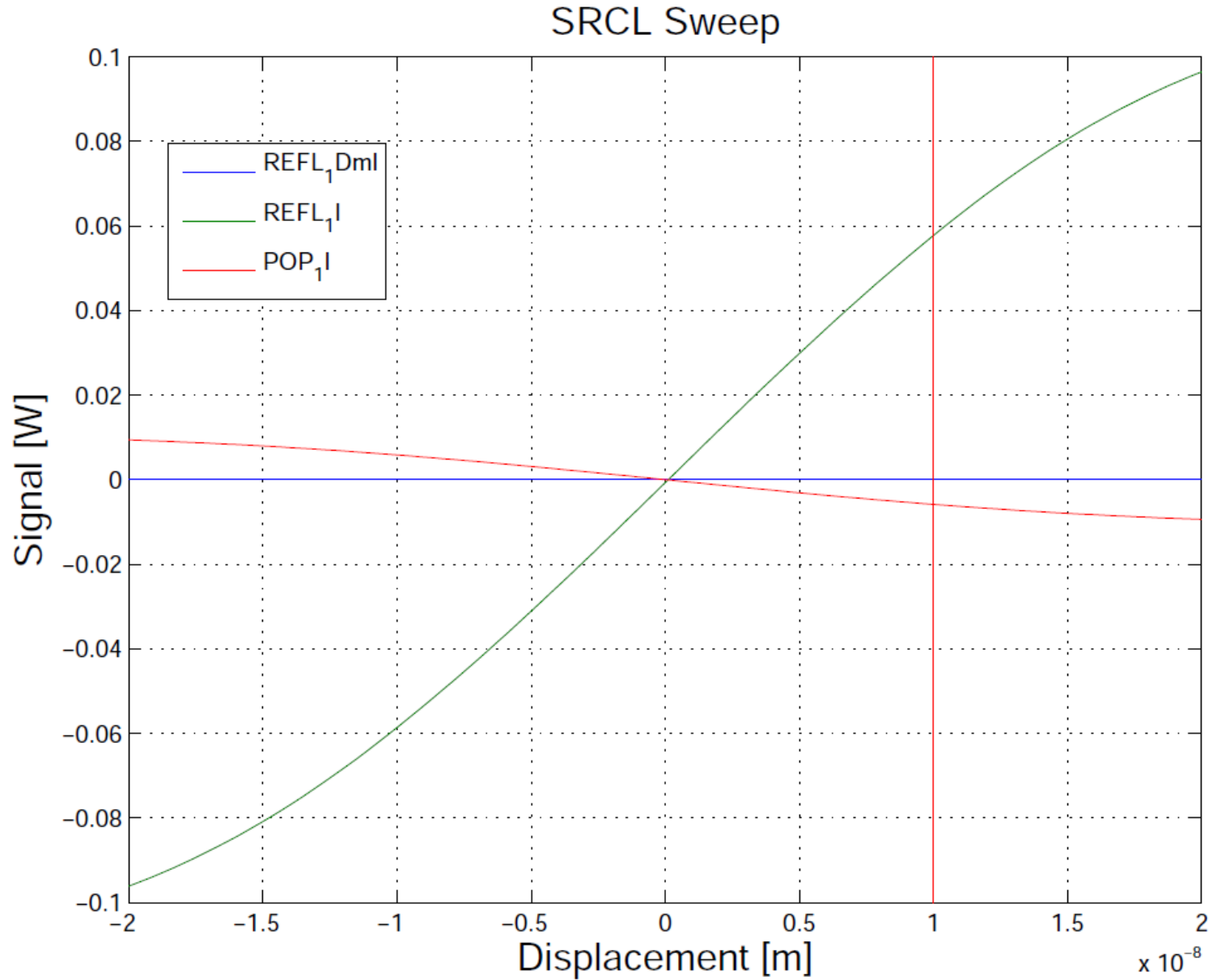

SRCL error signal range, f1=16.875MHz

b/a = 1.05e8 m⁻¹

f1=16.875MHz

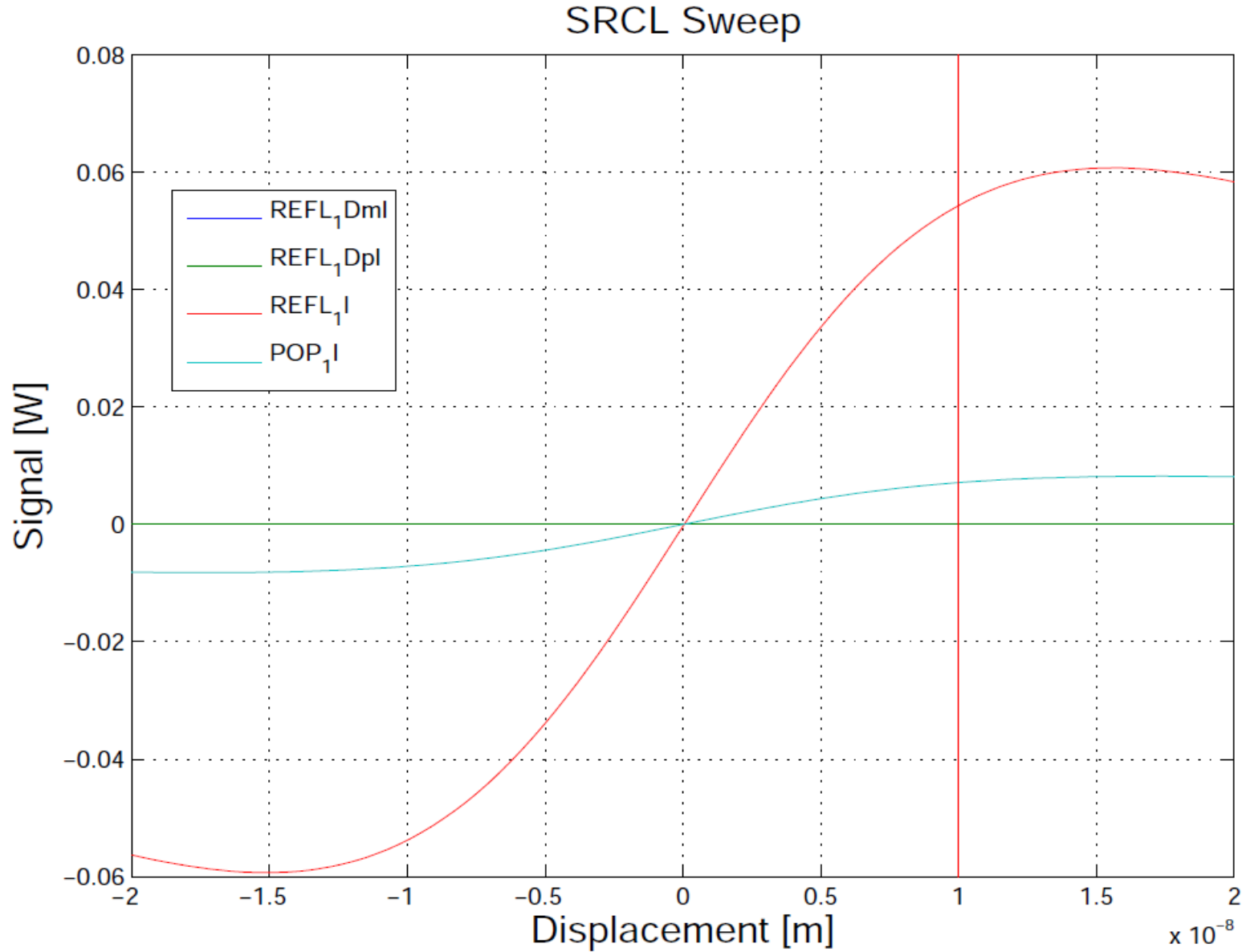

Up Conversion Noise

- **Blue Curve:** SAS displacement noise + SRCL shot noise
- **Green Curve:** Above noise suppressed by the servo
- **Red Curve:** Non-linear up conversion noise ($b/a=1e9$)

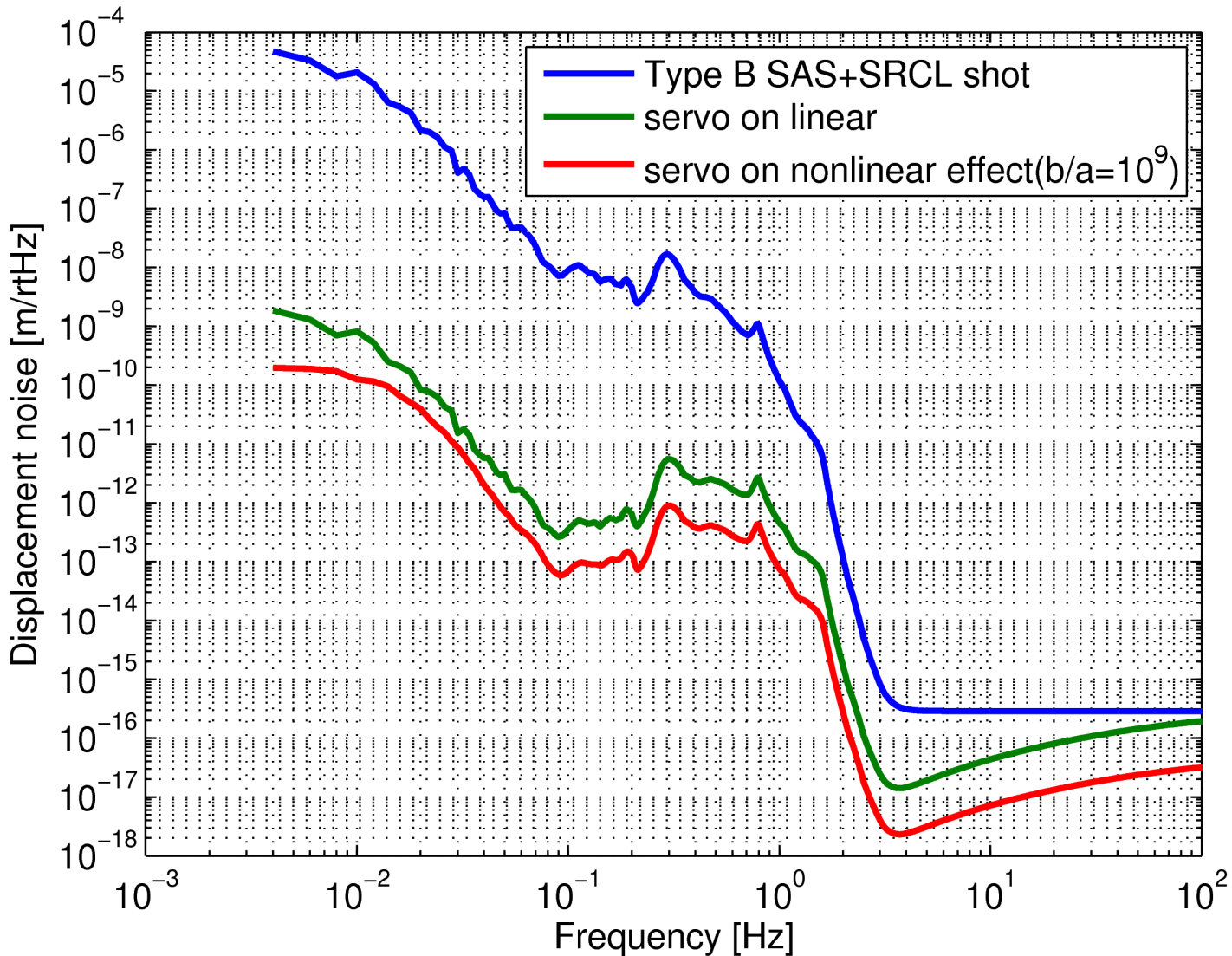

It does not seem to be a problem

PD Dynamic Range

Offsets in MICH and CARM --> Dynamic Range of RFPD circuit

SRC detuned: f1 SB is not at the peak of the resonance

- ▶ f1 gets some phase rotation at REFL and POP
- ▶ f1 is no longer pure PM for the carrier
- ▶ Large offset at PDs for f1 SB

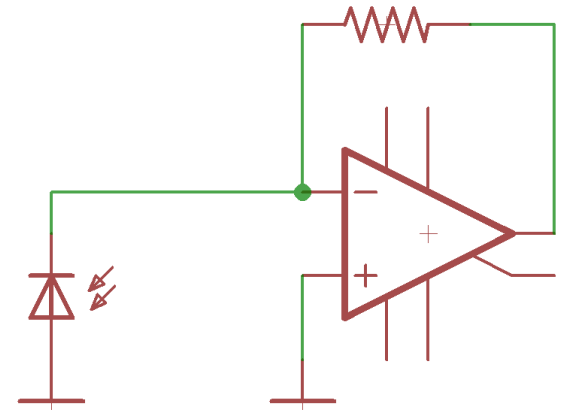

The buffer op-amp of the PD circuit has to handle this large RF signal

Max RF amplitude: $\sim 0.1V_{pp}$ (?) Slew rate and linearity \longrightarrow Dynamic Range $\sim 160dB$
Noise of the op-amp: $> 1nV/\sqrt{Hz}$

Actual Numbers

REFL_1 PD gets 55mW of offset RF signal@f1 frequency(16.875MHz) in DRSE

Input power equivalent noise of op-amp is $55mW/1e8/\sqrt{Hz} = 5.5e-10W/\sqrt{Hz}$

Sensitivity is $1.64e9 W/m$ for CARM, $2.0e6 W/m$ for MICH

Displacement equivalent op-amp noise is $3.4e-19m/\sqrt{Hz}$ for CARM, $2.7e-16m/\sqrt{Hz}$ for MICH

POP_1 PD gets 7.2mW of offset RF signal@f1 frequency(16.875MHz) in DRSE

Input power equivalent noise of op-amp is $7.2mW/1e8/\sqrt{Hz} = 7.2e-11W/\sqrt{Hz}$

Sensitivity is $3.3e5 W/m$ for SRCL

Displacement equivalent op-amp noise is $2.2e-16m/\sqrt{Hz}$ for SRCL

Risk: PD Noise Coupling

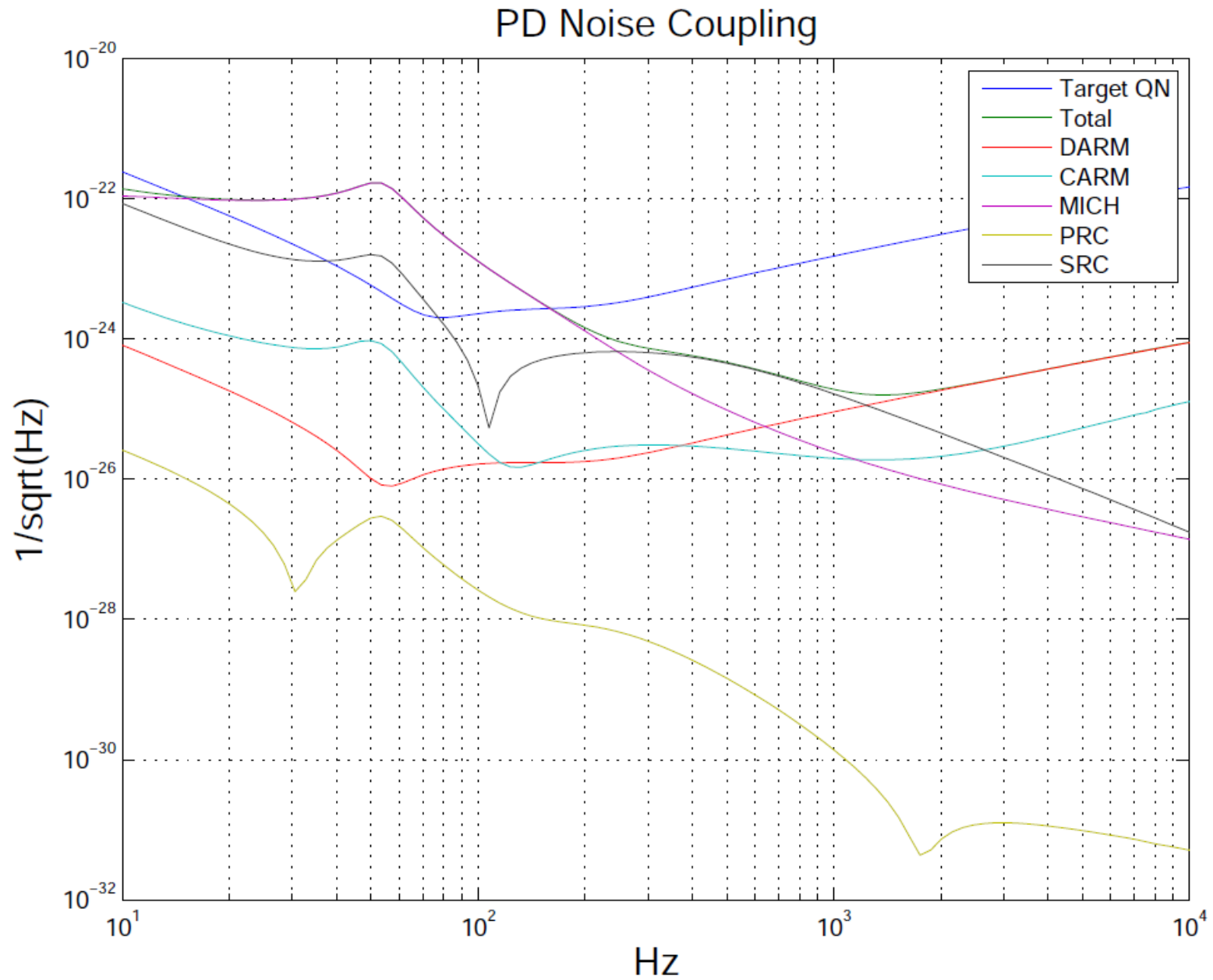

Risk: PD Noise Coupling with Feed Forward

PD Noise Coupling with Feed Forward

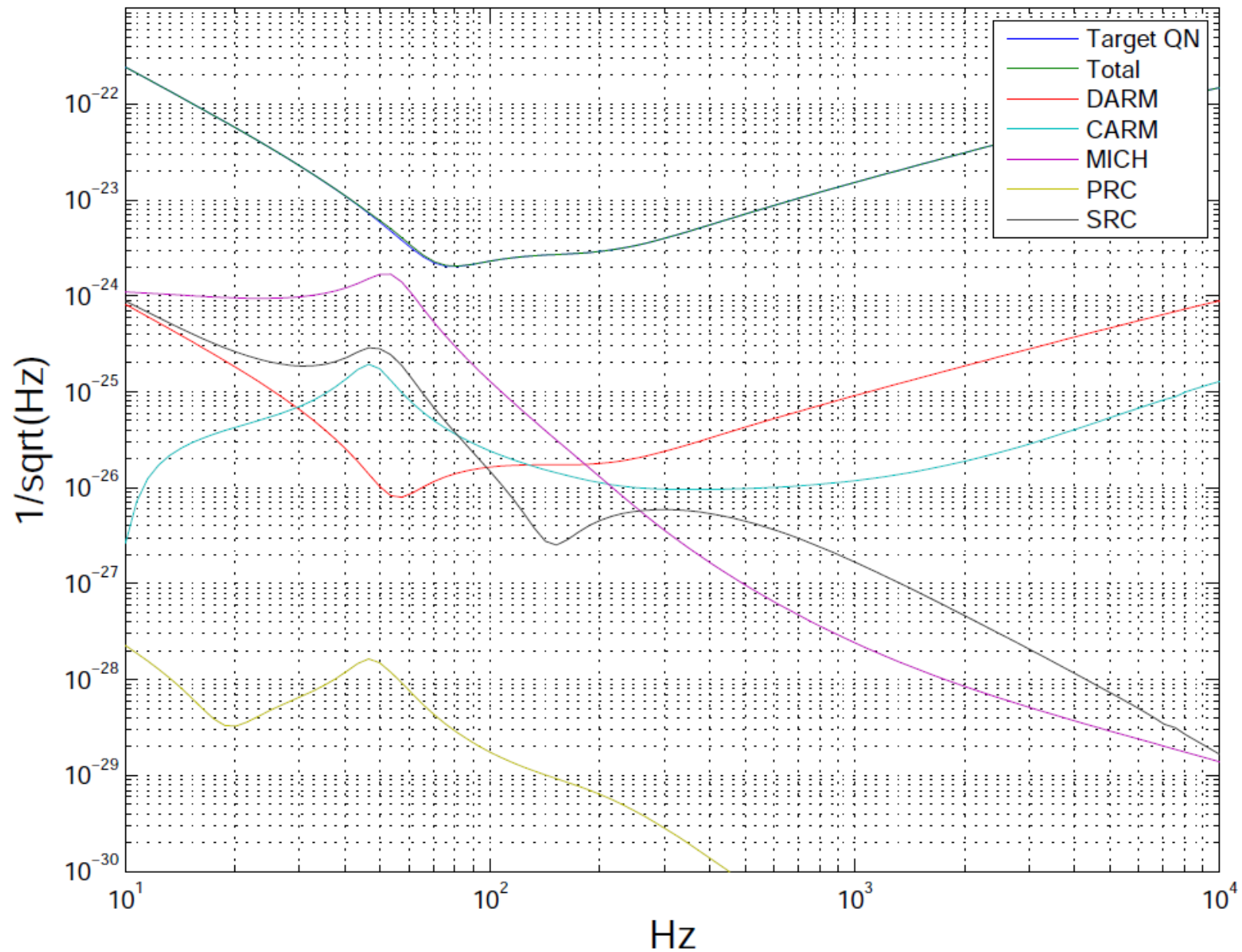

Risk: SRCL detuning by Offset

How to deal with the PD dynamic range problem ?

- Find a good op-amp with larger dynamic range
- Increase the feed forward gain
- Current injection to PD to cancel the large RF signal (like AS_I servo in iLIGO)
- Pre-rotate f1 sidebands

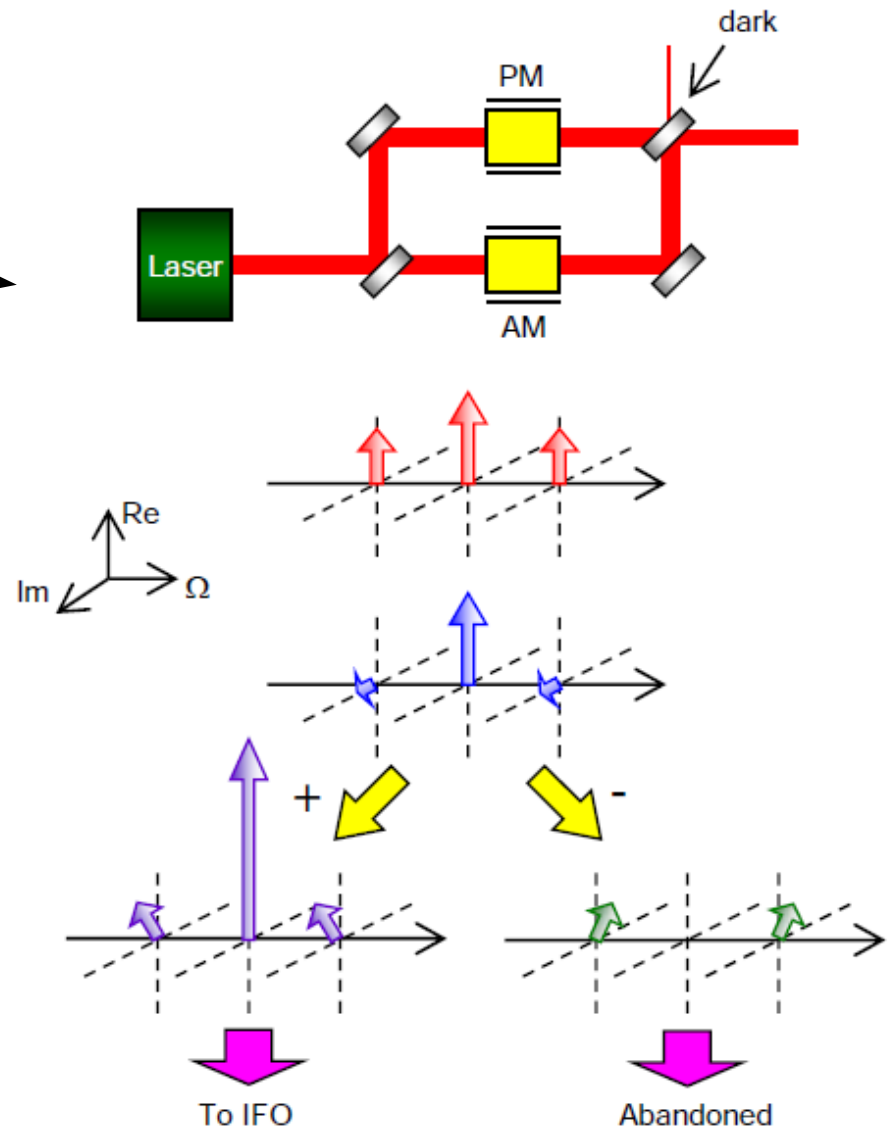

Conclusion on the Modulation Frequencies

	9MHz	11.25MHz	16.875MHz
Loop Noise	Good	OK	Good
SRCL Non-linearity	OK	OK	OK
3 rd Harmonics Demodulation	OK	No	OK
Lprc,Lsrc	74.95m	73.28m	66.62m
Asymmetry	6.66m	3.33m	3.33m
Lmc	33.3m	26.65m	26.65m
f3	13.5MHz($f_2 \cdot 3/10$)	61.9MHz($f_2 \cdot 11/8$)	56.3MHz ($f_2 \cdot 10/8$)
DDM freq.	22.5MHz, 31.5MHz	16.9MHz, 50.6MHz	11.25MHz, 39.4MHz

Displacement Noise Requirements

Formulation used here:

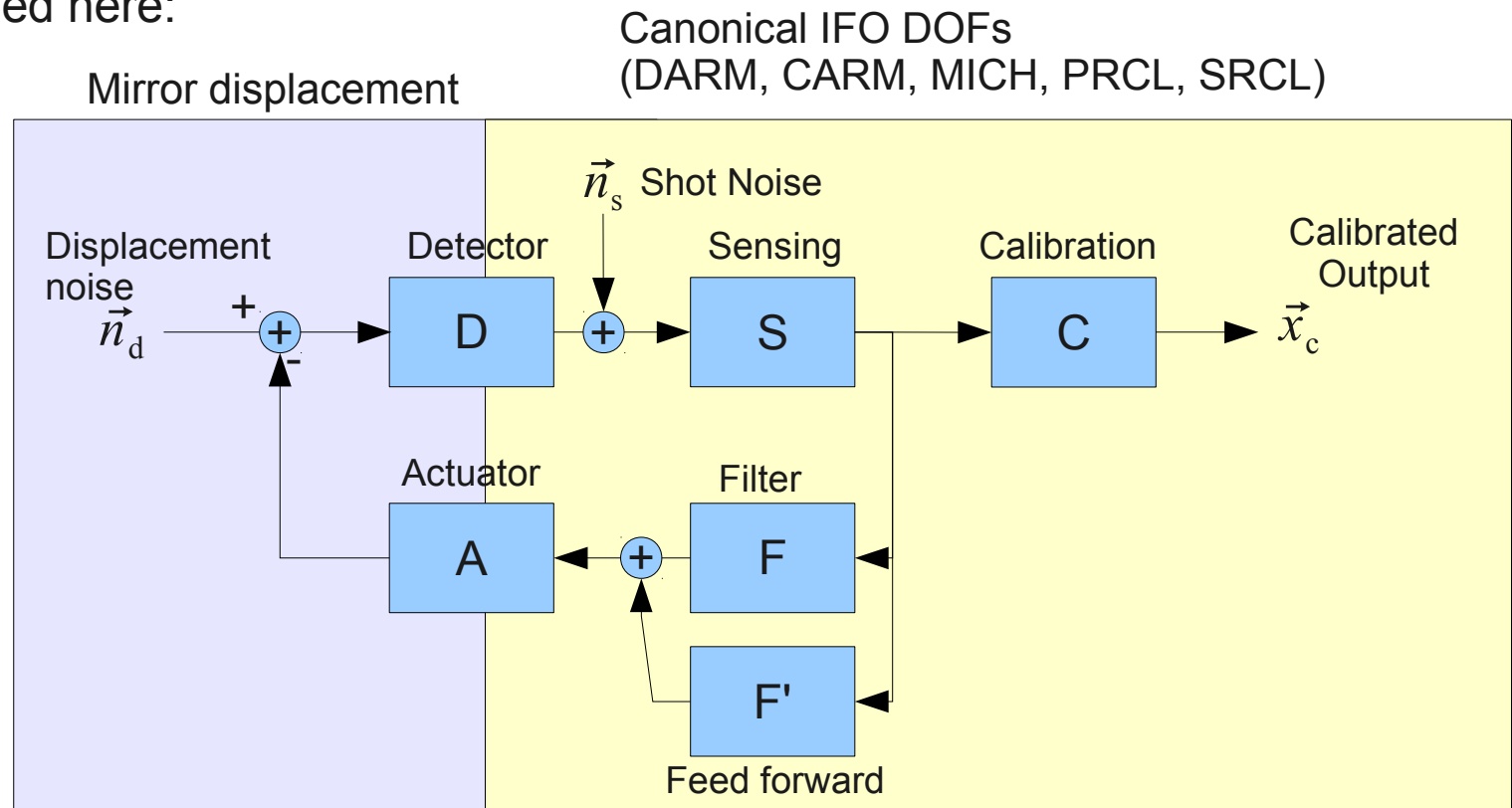

$$\vec{x}_c = (I + G)^{-1} \cdot S \cdot \vec{n}_s + (I + G)^{-1} \cdot SD \cdot \vec{n}_d$$

$$G \equiv S \cdot D \cdot A \cdot (F + F')$$

- $(I+G)^{-1}SD$: transfer function from n_d to x_c ← Safety factor
- Require n_d 's contribution to x_c to be 1/10 of DARM shot noise

→ Requirement on each mirror's displacement noise
(seismic, thermal, etc)

Displacement Noise Requirements

BRSE

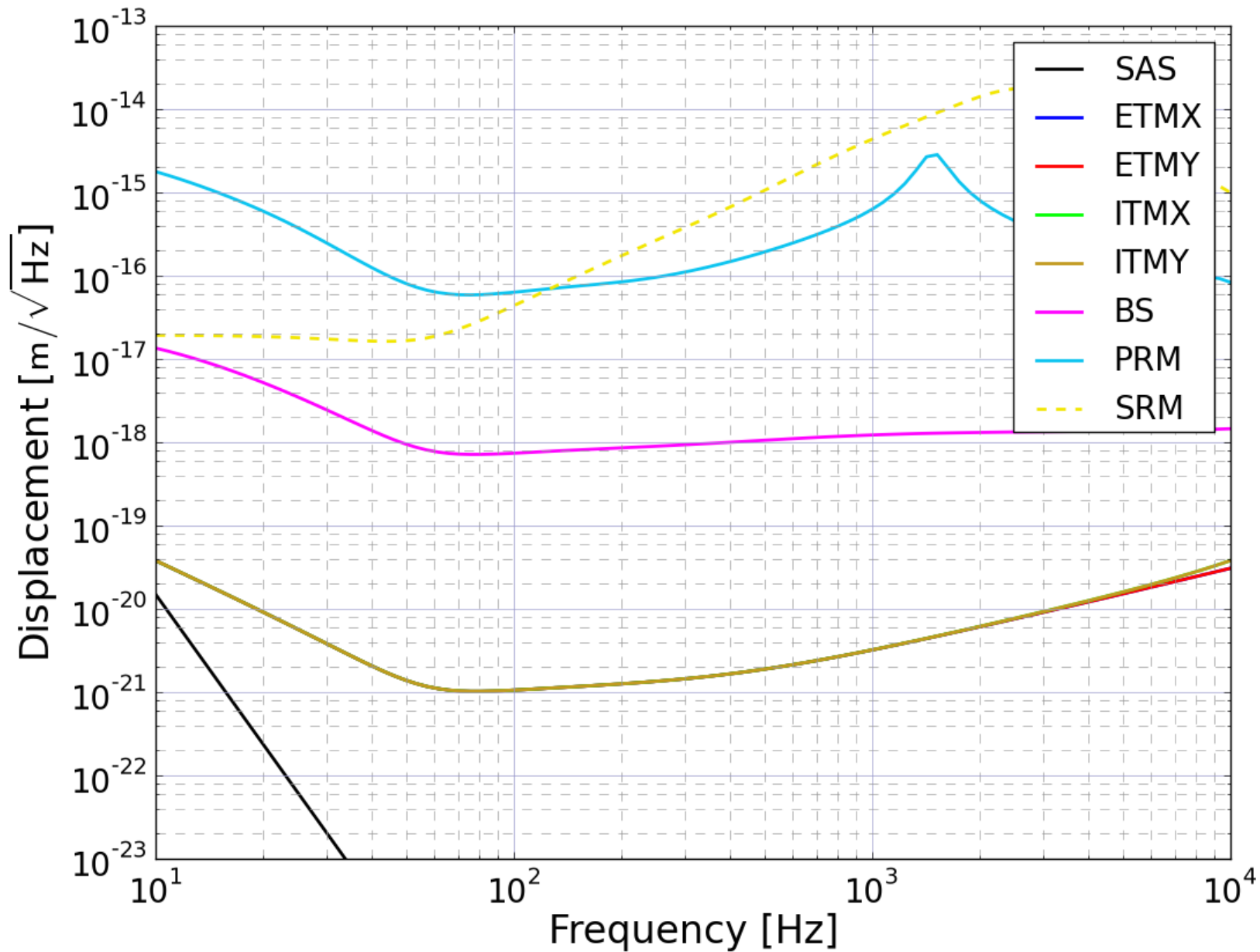

Displacement Noise Requirements

DRSE

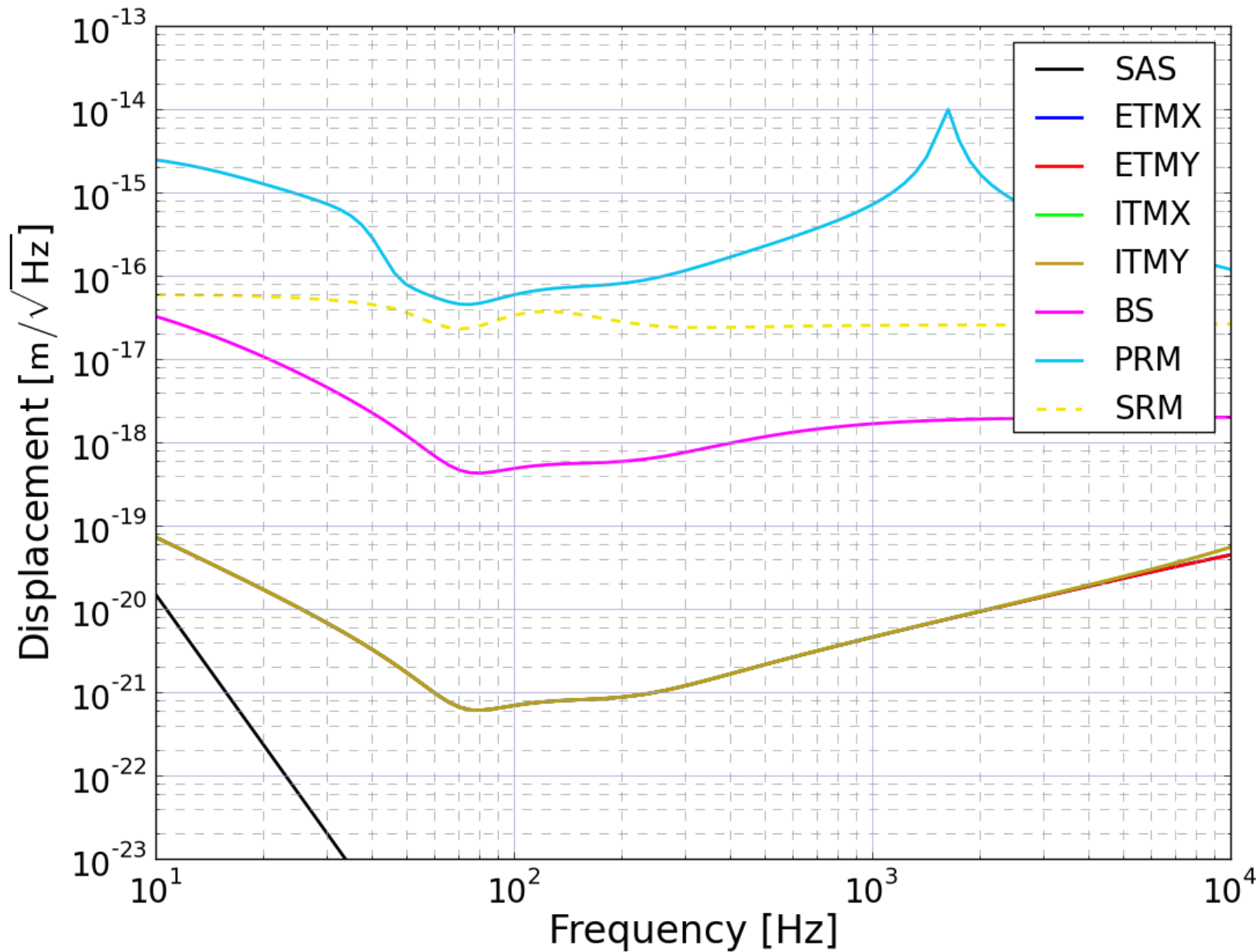

Folding of Recycling Cavities

Straight Recycling Cavity ==> Nearly Degenerated

How badly degenerated ?

g-factor ($g_1 * g_2$) = 0.9998
One-way Gouy Phase Shift = 0.7deg.
Transverse Mode Spacing = FSR/257
PRC Finesse = 57 (FWHM = FSR/57)
(PRCL = 42.5m, occupying the same tunnel space)

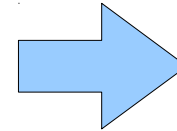

- HG(m,n) modes resonate up to $m+n = 2$
- LG(p,q) modes resonate up to $2 * p+q = 2$

The RFSB spatial modes are unstable (alignment fluctuation, thermal lensing)

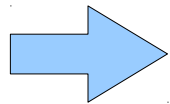

Folding the PRC and focusing the beam inside ==> **Stable PRC**

How about SRC ?

- f1 SB resonates in PRC-SRC
- If PRC is stable, HOMs cannot resonate in PRC-SRC.
- No need to fold SRC ? -> Not so simple
- GW sidebands may be scattered to HOMs by mode mismatch between the arm cavities and SRC.
- The loss of GW sidebands is higher for degenerated SRC

(Kip Thorne & Yi Pan)

SRC Folding

Yi Pan's report (LIGO-T-060004): ITM ROC error of 0.25% ==> Up to 2% GW Signal Loss
 $\text{Loss} \propto (\text{ITM Error})^2 \implies 1\% \text{ error} \rightarrow 32\% \text{ signal loss}$

The situation for LCGT should not be too different from aLIGO

But we should check it anyway

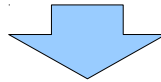

- HOM simulation using Finesse
- No definitive answer yet
- Large (1W) TEM00 leak at AS port if not folded
- Seems like non-folded SRC is bad

For the moment, the default design is to fold SRC

- Cost increase (two more vacuum tanks, suspensions, mirrors)
- Additional control of SR2, SR3 alignment (we have to control PR2, PR3 anyway)
- Folded SRC provides a convenient port for green laser injection
- The beam size at AS is smaller and easy to handle (4mm)
- If necessary, the tunnel can accommodate straight SRC ($L_{\text{src}}=40\text{m}$)

Folding Design

How Stable ?

- HOM isolation ==> Stable is better
- Too stable ==> Arm alignment signal is suppressed
- Compromise between HOM and ASC ==> One-way Gouy Phase Shift = 20deg.

Not Optimized Yet

How to fold the PRC/SRC ?

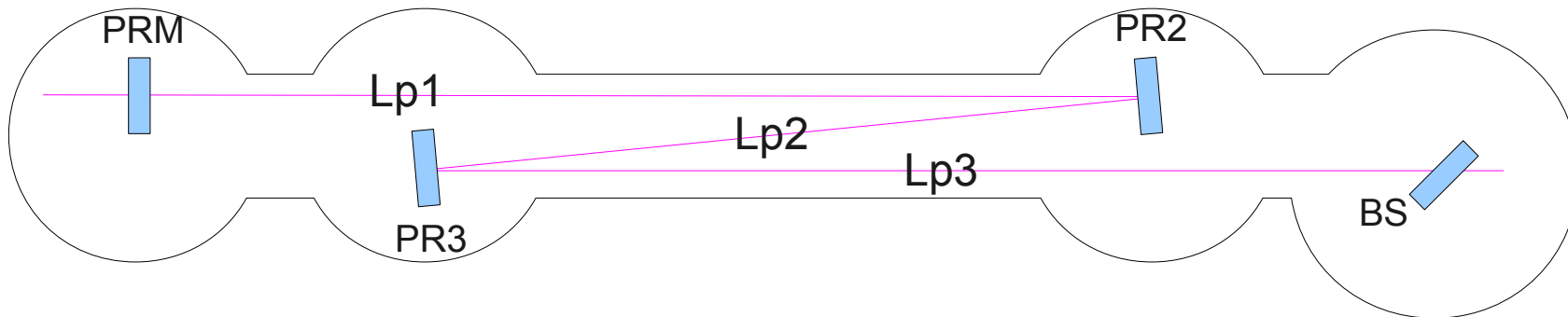

Constraints

- Minimum vacuum chamber spacing: 2.7m
- Astigmatism: Smaller folding angle is better ==> Longer Lp2

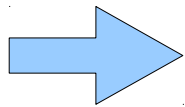

Mirror locations are almost uniquely determined

Play with ROCs of PR2 and PR3

Beam Width Change in PRC

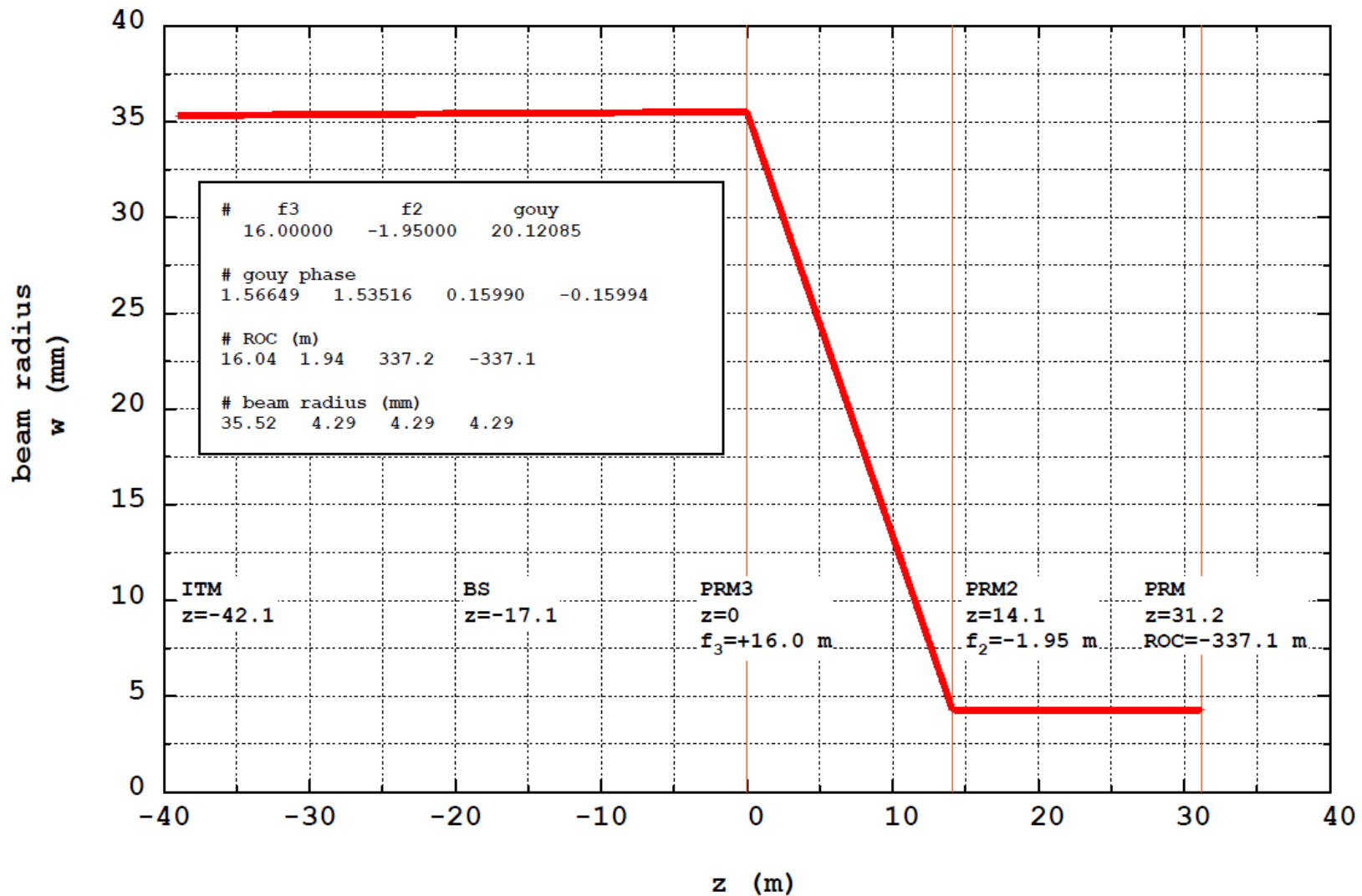

Folding Optimization

Mirror distances: fixed
One-way Gouy phase: 20deg

Small Beam Spot ==> Large Thermal Lensing

Beam Size on the Mirrors vs PR3 focal length

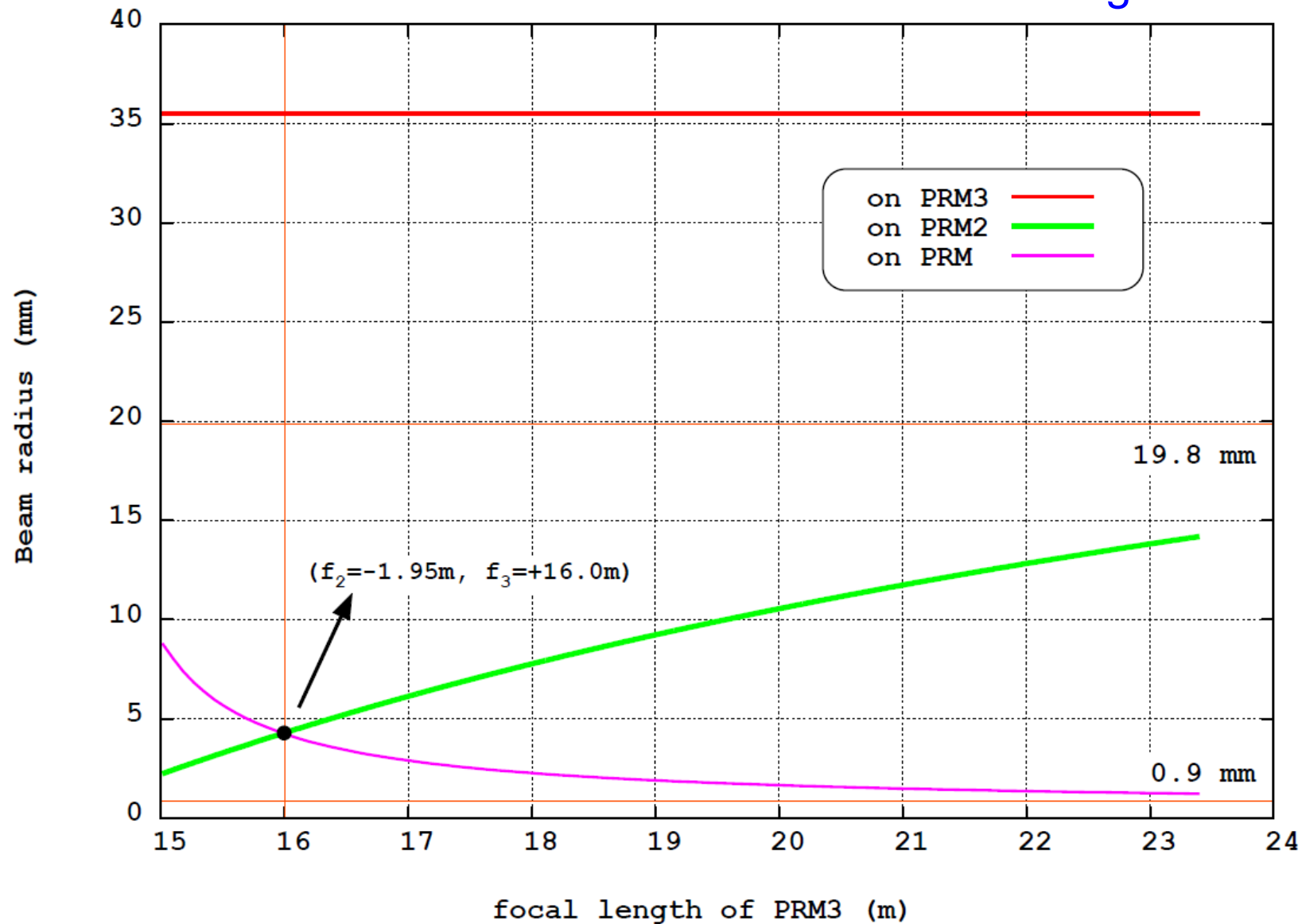

Thermal Lens

ITM Lensing

1W heat deposit
on the mirror



ROC=11661km, No Problem
Thanks to the high thermal conductivity of sapphire

1mK Temperature Raise

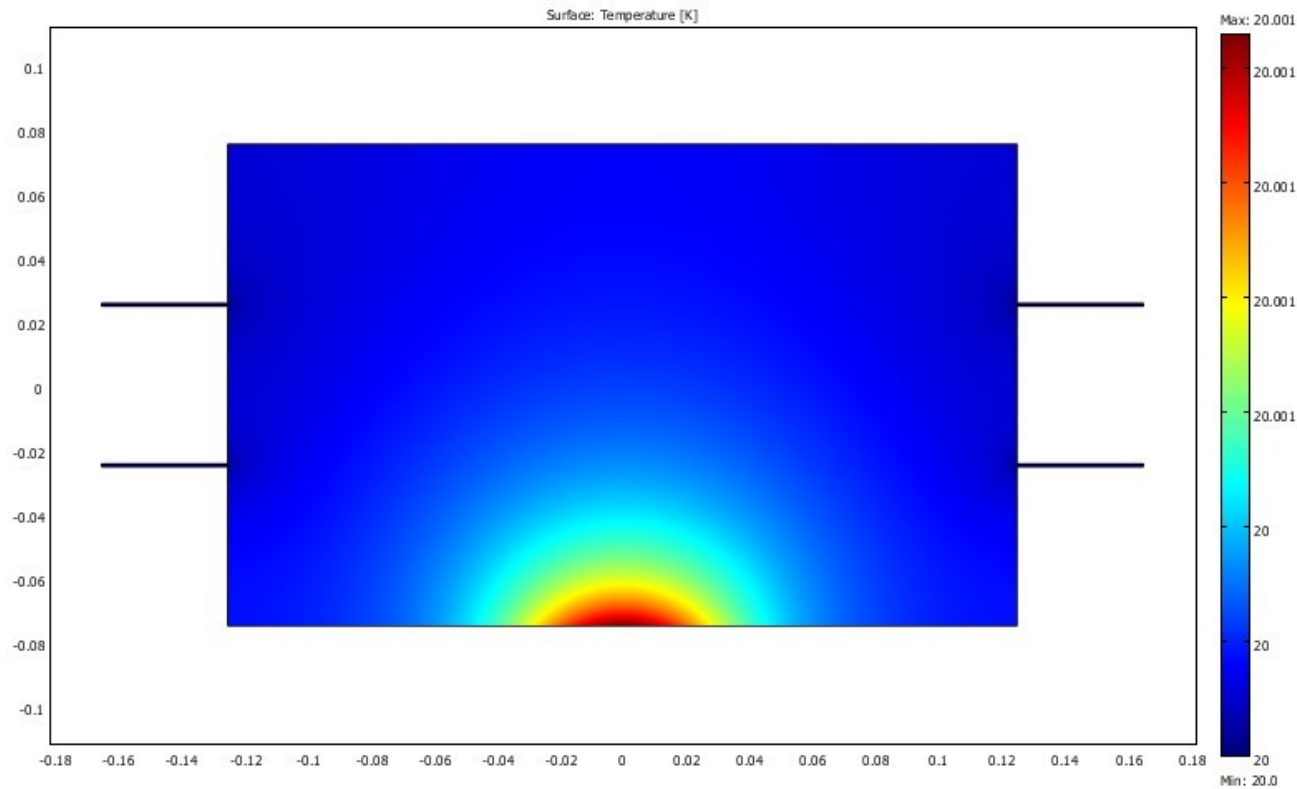

Calculation by Muzammil A. Arain (UFL)

Thermal Lens

PRM, PR2

Beam Spot Size: 4mm
Power on HR: 800W

PR3, BS

Beam Spot Size: 35mm
Incident Power: 800W

	PRM	PR2	PR3	BS
10ppm absorption	18% ROC error	0.2% ROC error	0.3% ROC error	ROC 100km
1ppm absorption	2% ROC error	0.02% ROC error	0.03% ROC error	ROC 1000km

ROC Error of PR2, PR3

Very Sensitive to PR3 ROC Error

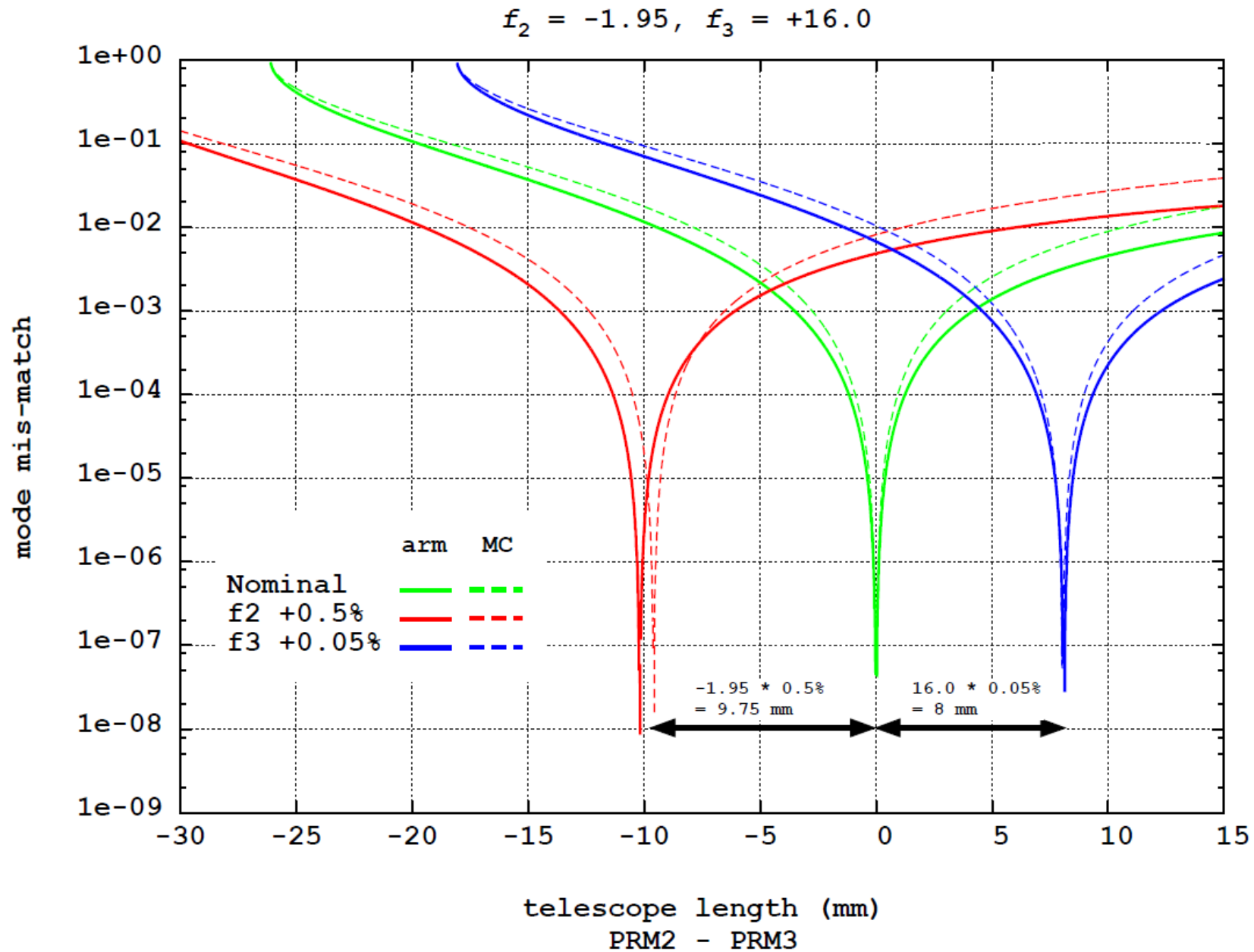

How to Handle PR3 ROC error ?

iLCGT

- No SAS. Suspensions can be easily moved by more than 10cm
- PR2 and PR3 for iLCGT will be used in bLCGT
- PRM is a blank with curvature

bLCGT

- PR2 and PR3 position can be changed by more than 10cm at the installation time
- After installation, it takes time to move them

Installation and Adjustment Plan

1. Make PR2 and PR3
2. Measure the ROCs of PR2 and PR3
3. Install them to iLCGT
4. Adjust the location of PR2 and PR3 to form the desired telescope
5. Remember the optimal location of PR2 and PR3
6. Measure the ROC of PRM, which match the actually formed PRC.
7. Order a PRM according to the measured ROC.
8. Install PR2 and PR3 at the remembered positions for bLCGT
9. Install the PRM

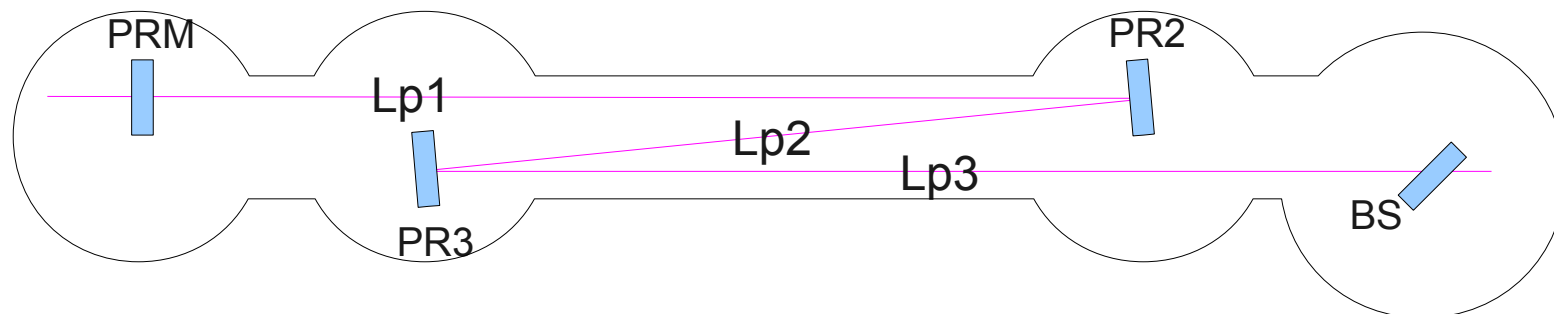

Modulation frequency Fine adjustment

f1 and f2 SBs are not exactly anti-resonant to the arm cavities

- f1 and f2 get finite phase shifts from the arm cavities
 - In general, f1 and f2 cannot fully resonate in the PRC at the same time
- Fine adjust the MC length (thus f1, f2 frequencies) to achieve
$$\Phi_1:\Phi_2 = f_1:f_2$$
(Φ_1 : phase shift of f1 by the arm, Φ_2 : phase shift of f2 by arm)
- Lprc and Lsrc are adjusted accordingly

Locations of RF SBs in the FSR of AC

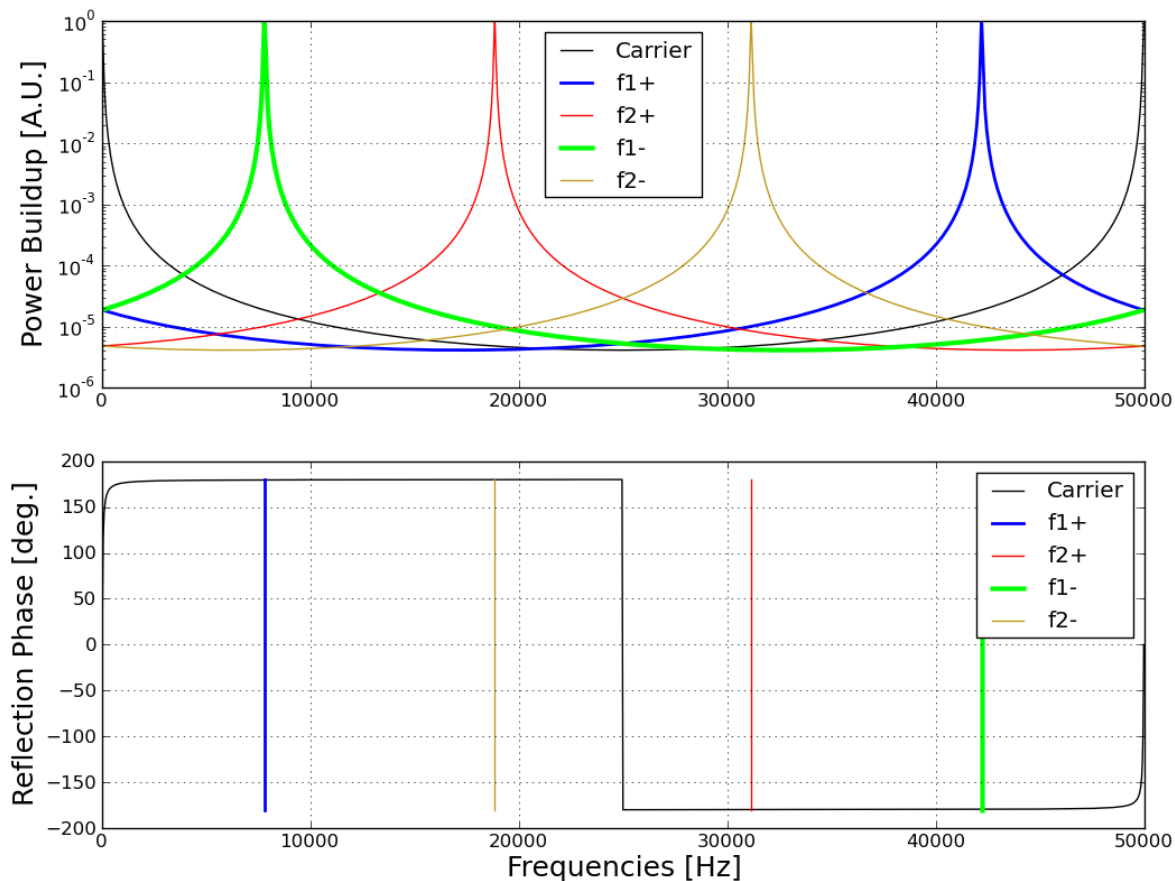

Lmc adjustment = -1.37cm

f2 resonance

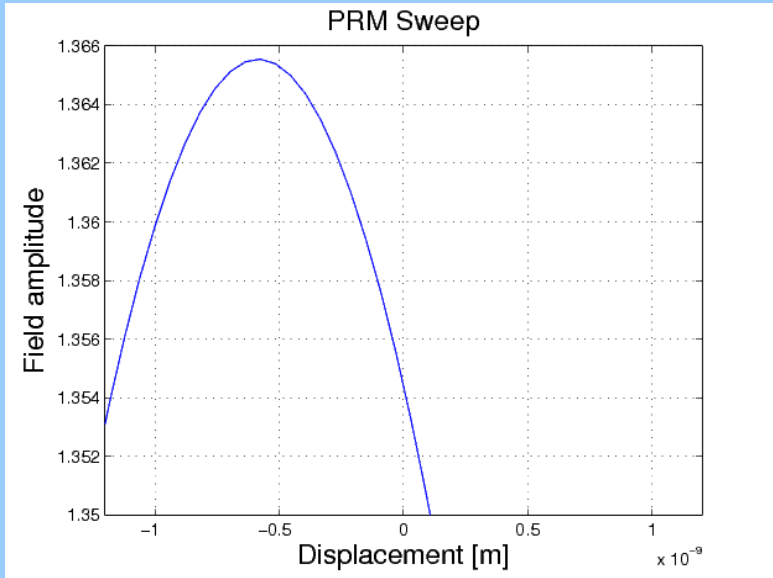

Adjust Lprc
by 3.7mm

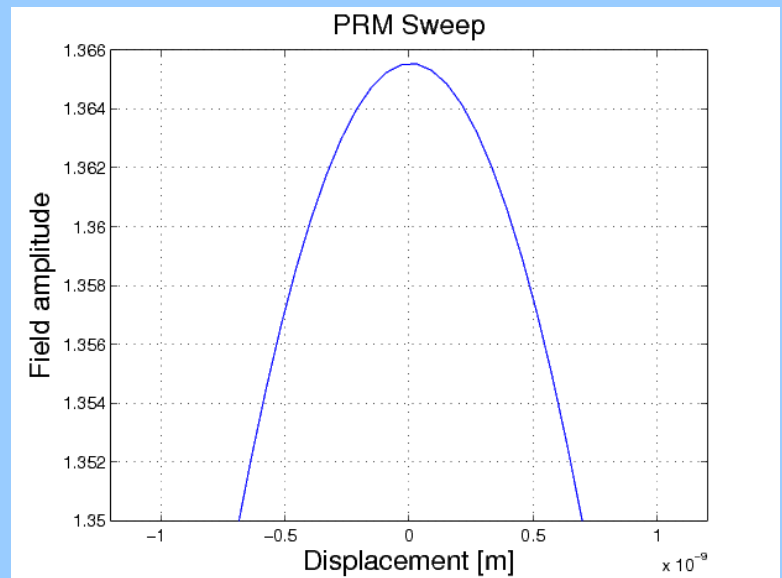

f1 resonance

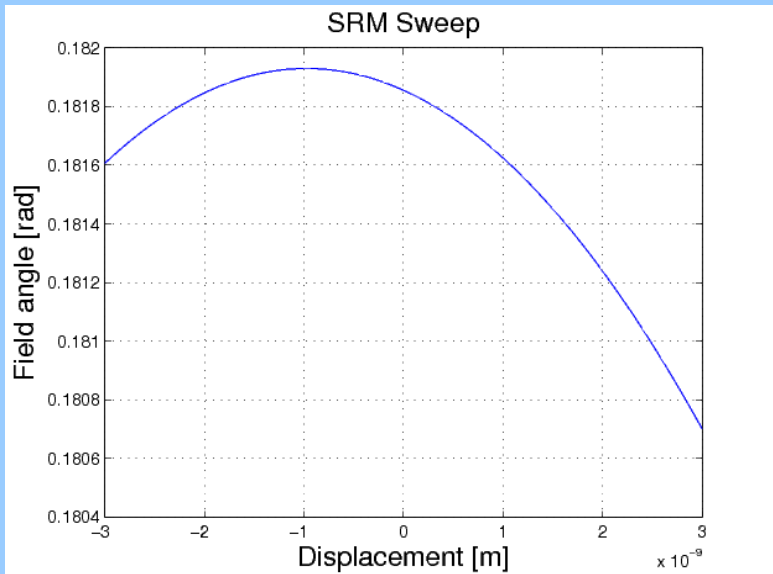

Adjust Lsrc
by 7.4mm

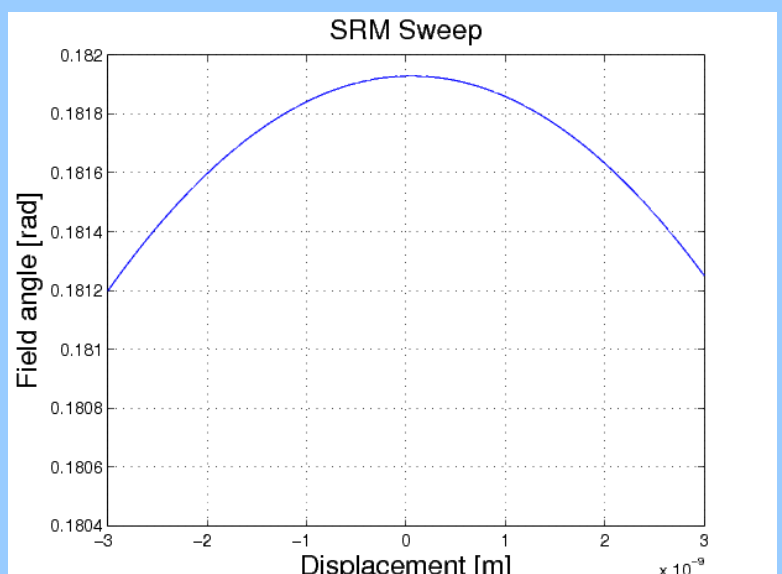

Alignment Sensing and Control

Basic Strategy

Combination of Wave Front Sensing (WFS) and Optical Levers

Arm Cavity Misalignment Modes

Combinations of the ITM, ETM rotation to diagonalize the angular stiffness matrix

————▶ Hard - Soft basis

[Common Hard (CH), Common Soft (CS), Differential Hard (DH), Differential Soft (DS)]

Folding and ASC

- RCs are very stable --> TEM₀₁ and TEM₁₀ modes are suppressed
 - No ASC signal of TMs
- One-way Gouy phase shift in RCs --> about 20 deg.
- Needs optimization
- What to do with the alignment of folding mirrors ?
 - Not enough DOF from WFS
 - Control a linear combination of PRM, PR2, PR3 angles ?
 - Is it stable ?

Simulations with Optickle (Pickle), work in progress

bLCGT ASC Sensing Matrix

Angle Sensing Matrix [W/rad]

POY B Q2	-5.54	-4.5	-132	155	0.392	0.363	0.443	-0.00311	-0.00591	-0.0496	-372
POY B I2	1e+003	-1.17e+003	856	-1.22e+003	-84.6	-935	-7.9e+003	-0.0162	-0.0309	-0.259	-68.3
POY A Q2	97	98.2	-1.15e+003	1.23e+003	-5.64	-1.35	39.5	-0.0131	-0.025	-0.209	-3.05e+003
POY A I2	-145	-23	1.06e+003	-1.15e+003	9.92	54.2	412	0.00955	0.0182	0.152	3e+003
POY B Q1	-76.9	33	42.8	48.3	2.66	36.2	310	-0.143	-0.271	-2.27	67.1
POY B I1	-58.1	61.4	54.9	-50.7	3.31	49.3	426	-1.59	-3.03	-25.4	283
POY A Q1	-135	155	135	-155	11.6	127	1.07e+003	-0.00453	-0.00862	-0.0723	758
POY A I1	184	-20.2	-190	40.7	-7.69	-83.8	-705	7.85	14.9	125	-536
POX B Q2	675	-851	-1.07e+003	1.37e+003	-57.9	-658	-5.58e+003	0.00518	0.00985	0.0825	-5.16e+003
POX B I2	-591	761	810	-1.06e+003	50.8	583	4.94e+003	-0.00955	-0.0182	-0.152	4.2e+003
POX A Q2	54.1	-57.8	87	-111	-4.48	-48.1	-406	-4.26e-005	-8.09e-005	-0.000678	115
POX A I2	459	-267	1.21e+003	-1.21e+003	-35.3	-313	-2.58e+003	0.0202	0.0384	0.322	2.21e+003
POX B Q1	-16.4	31.1	17.2	-52.7	0.0136	10.4	95.9	2.01	3.82	32	125
POX B I1	-1.75	3.3	5.88	-11	1.09	2.02	8.96	1.93	3.66	30.7	24.2
POX A Q1	223	-62.1	219	-57	-10.3	-116	-976	7.51	14.3	120	-3.85
POX A I1	-102	156	-103	157	10.1	114	966	0.998	1.9	15.9	5.74
POP B Q2	5.91	4.14	-0.136	0.165	-0.436	-0.812	-4.21	1.4e-006	2.65e-006	2.22e-005	-1.74
POP B I2	-1e+003	1.17e+003	-1.77	2.36	84.8	938	7.93e+003	-0.000147	-0.000279	-0.00234	2.8e+003
POP A Q2	18.9	-135	0.569	-0.589	-3.01	-65.6	-582	1.24e-005	2.36e-005	0.000197	-206
POP A I2	63.4	188	-0.585	0.451	-2.09	52.7	509	-1.01e-005	-1.92e-005	-0.000161	182
POP B Q1	-43.4	4.25	7.14	-9.18	0.965	11.4	96.3	0.579	1.1	9.23	41.3
POP B I1	9.22	-1.14	34.8	-43.7	-0.208	-2.51	-21.3	-0.116	-0.22	-1.85	97.3
POP A Q1	-0.796	0.931	-155	195	0.055	0.594	5.01	0.000227	0.000432	0.00362	-452
POP A I1	-82.2	-64	-0.395	-0.193	0.423	4.12	33.7	-6.81	-12.9	-109	12.7
AS B Q1	-0.628	2.78	-922	-491	-0.0259	-4.5	-41.5	-0.000256	5.91	53.6	-166
AS B I1	85.6	-125	6.65e+003	3.81e+003	-4.38	-45.2	-378	3.76	-36.5	-336	535
AS A Q1	-42.5	53.1	0.98	-34.7	3.75	41.8	354	-0.103	-0.19	-1.59	176
AS A I1	51.6	-18	-1.95e+004	-1.5e+004	-2.56	-34.6	-296	-1.3	5.64	51.2	-2.02e+003
REFL B Q2	-445	97.4	-1.51	2.35	5.28	236	1.9e+003	-4.01e-005	-7.62e-005	-0.000639	660
REFL B I2	-1.08e+004	-9.77e+003	8.28	14.8	-871	571	-570	0.000124	0.000235	0.00197	-490
REFL A Q2	-9.58e+003	-4.22e+003	-3.41	22.5	-356	2.27e+003	1.55e+004	-0.000239	-0.000455	-0.00381	5.27e+003
REFL A I2	-1.08e+004	-5.39e+003	-1	22.6	-448	2.3e+003	1.51e+004	-0.000219	-0.000416	-0.00349	5.1e+003
REFL B Q1	-26.4	-11	-943	1.19e+003	0.0786	4.98	39.8	-1.43	-2.71	-22.7	-2.75e+003
REFL B I1	-1.84e+003	-1.46e+003	21.1	-27.6	-110	158	685	-40.6	-77.2	-647	279
REFL A Q1	-1.23	10.9	-978	1.23e+003	1.57	3.41	36.1	-0.787	-1.5	-12.5	-2.85e+003
REFL A I1	-2.05e+003	-1.47e+003	7.32	-10.2	-99.4	194	955	-36.5	-69.5	-582	294
	CS	CH	DS	DH	PRM	PR2	PR3	SRM	SR2	SR3	BS

Lock Acquisition

Principle: Lock acquisition has to be a deterministic process

Lock acquisition steps

1. Pre-lock the arms at off-resonant positions (Green laser pre-lock)
2. Lock the central part using the third harmonics demodulation or non-resonant sideband
3. Reduce the arm offset to the full resonance
4. The error signals to low noise ones

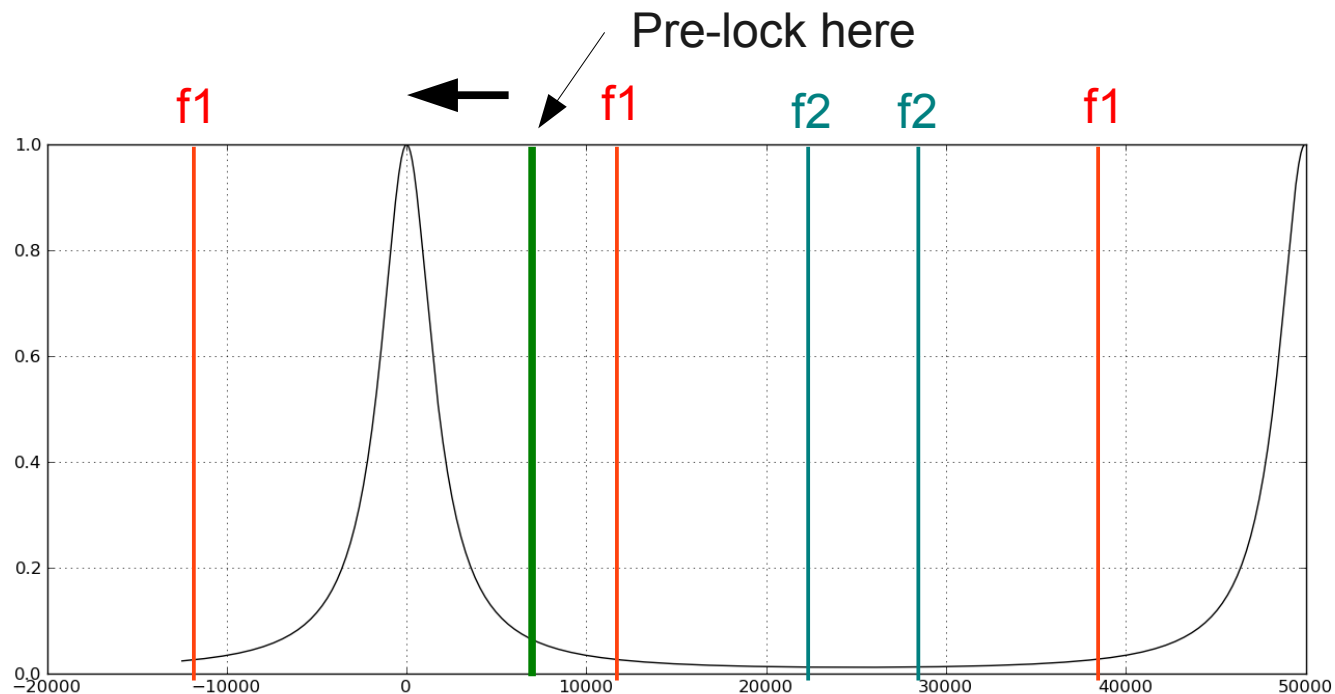

Green Laser Pre-Lock

Basic ideas for green laser lock

- Two green lasers (Frequency doubled from 1064nm)
- Green lasers are phase locked to the main laser by PLL
- Green Lasers are injected from PR2 for X-arm, and SR2 for Y-arm
- PR3 and SR3: High reflectivity for green (>90%)
- BS is transparent to green
- Arm finesse for green is low (~10)
- Two green lasers are frequency shifted by ~ 100MHz

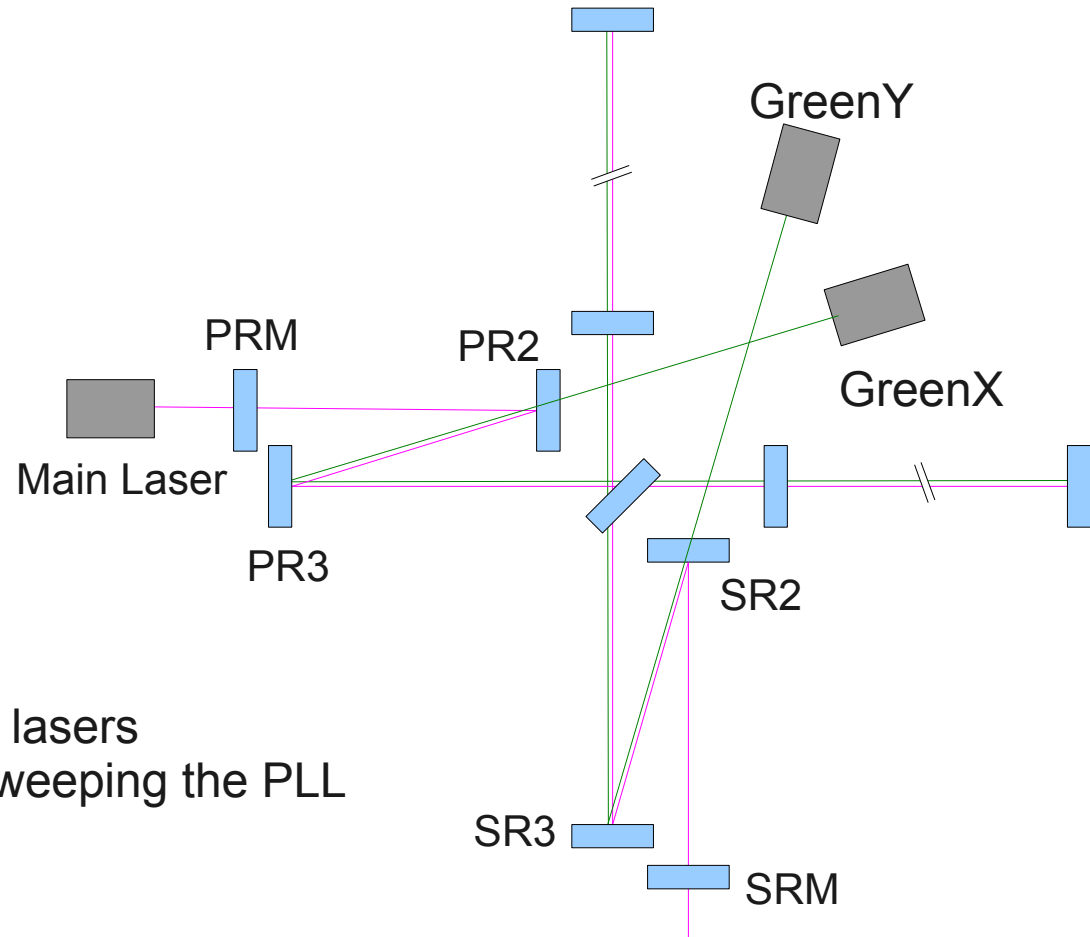

- Lock the arms independently by the green lasers
- Arm cavity length can be finely tuned by sweeping the PLL

Third Harmonics Demodulation

- Beat between $2*f_1$ and f_1 (Insensitive to the arms)
- Useful for lock acquisition.
- Substitutes for NRS. No MZ, no AM necessary -> simple.

Unfortunately, all the f_1 candidates cannot use this method in the usual sense, because $2*f_1$ resonates in the PRC-SRC.

(f_1 frequencies tested: 9MHz, 11.25MHz, 13.5MHz, 16.875MHz, 19.3MHz)

Actually, 3rd harmonics demodulation produces some signal due to difference in the response of $2*f_1$ and f_1 .

However, strong interference from the carrier is present (carrier- $3*f_1$ beat).

Sensing Matrix [W/m]

POP_1ThI	-1.0e+01	5.9e+02	-2.7e+03	-8.7e+03	2.3e+02
REFL_2ThI	1.3e+03	2.1e+05	5.5e+03	5.4e+05	-8.2e+01
REFL_1ThQ	5.1e+04	9.2e+06	2.9e+05	-1.7e+05	-4.3e+02
REFL_1ThI	3.0e+04	5.4e+06	-1.2e+05	2.0e+06	1.2e+06
	DARM	CARM	MICH	PRC	SRC

@100Hz

Third Harmonics Demodulation

3rd Harmonics signal during lock acquisition

CARM offset: 2nm -> 0

MICH is affected by CARM

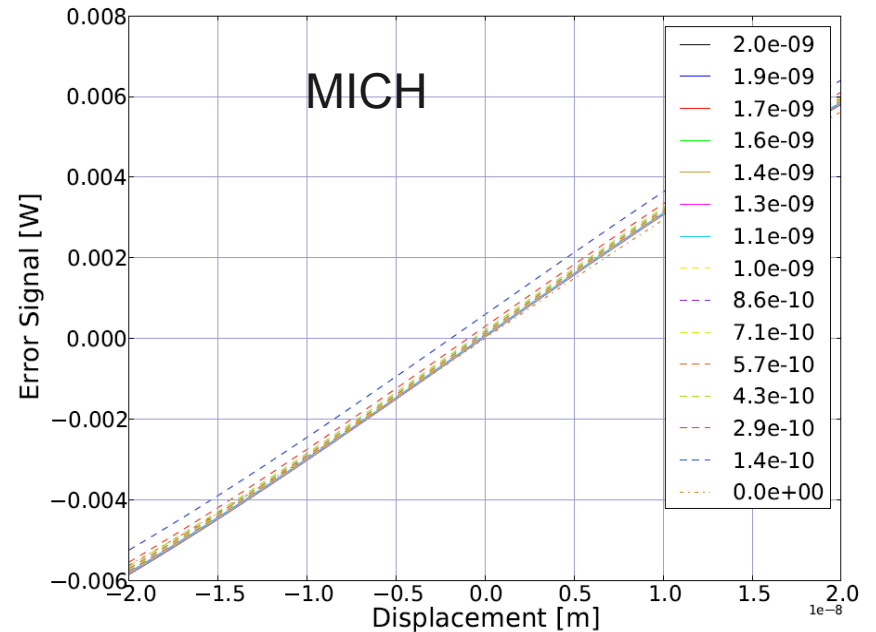
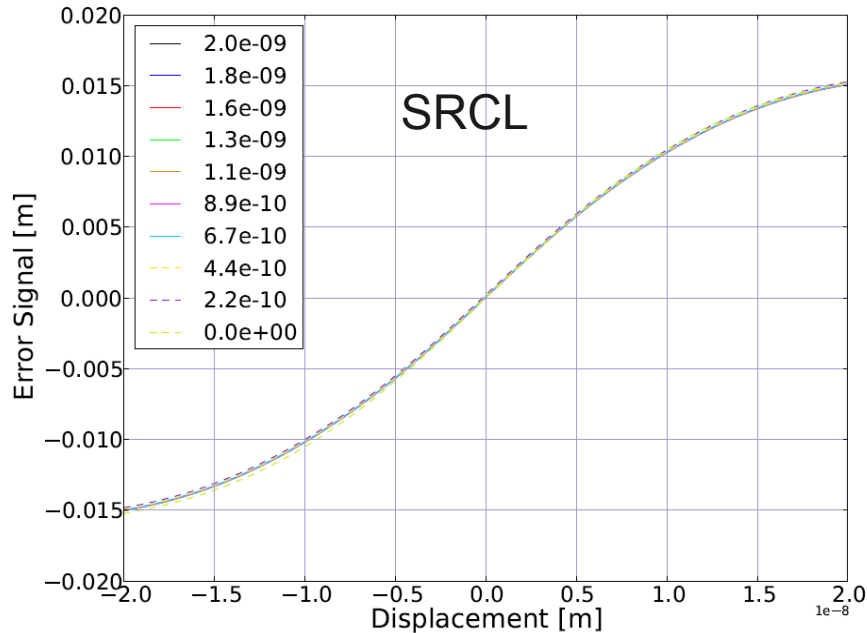
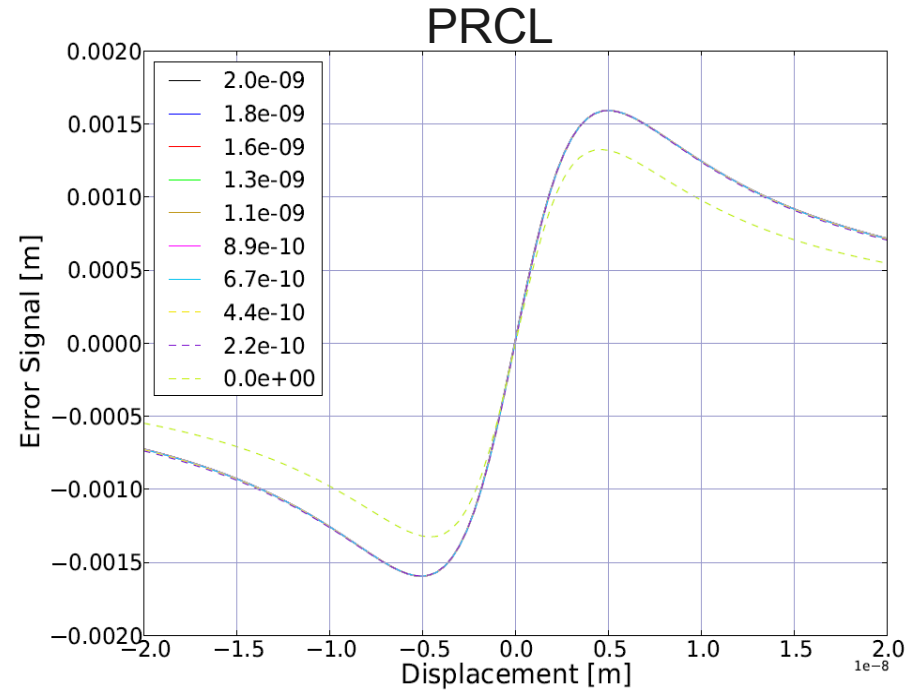

Non-Resonant Sideband for Lock Acquisition

NRS serves as a local oscillator
insensitive to the arms

NRS signals during the lock acquisition

CARM offset: 2nm \rightarrow 0

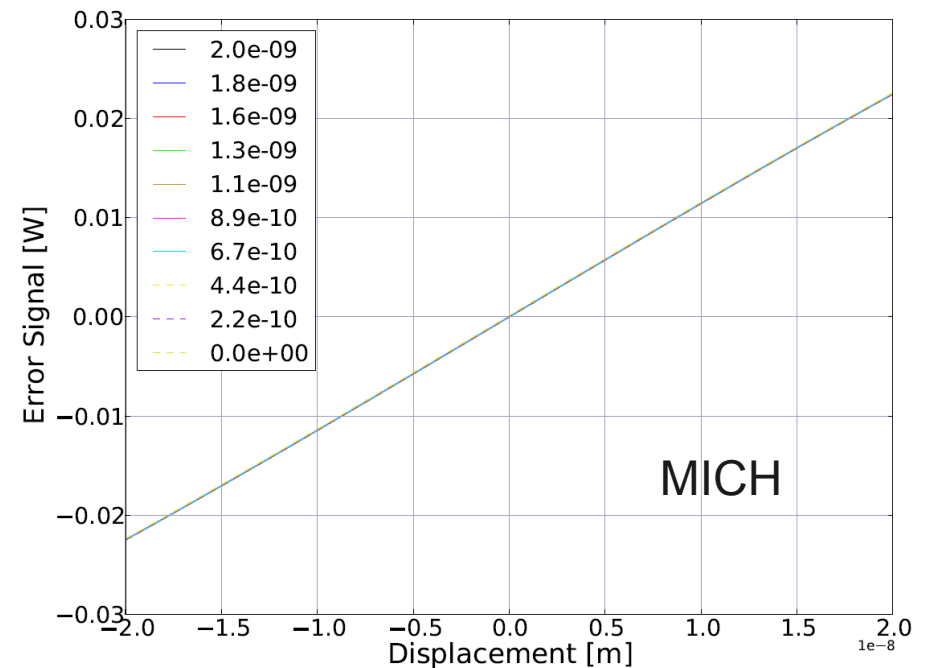
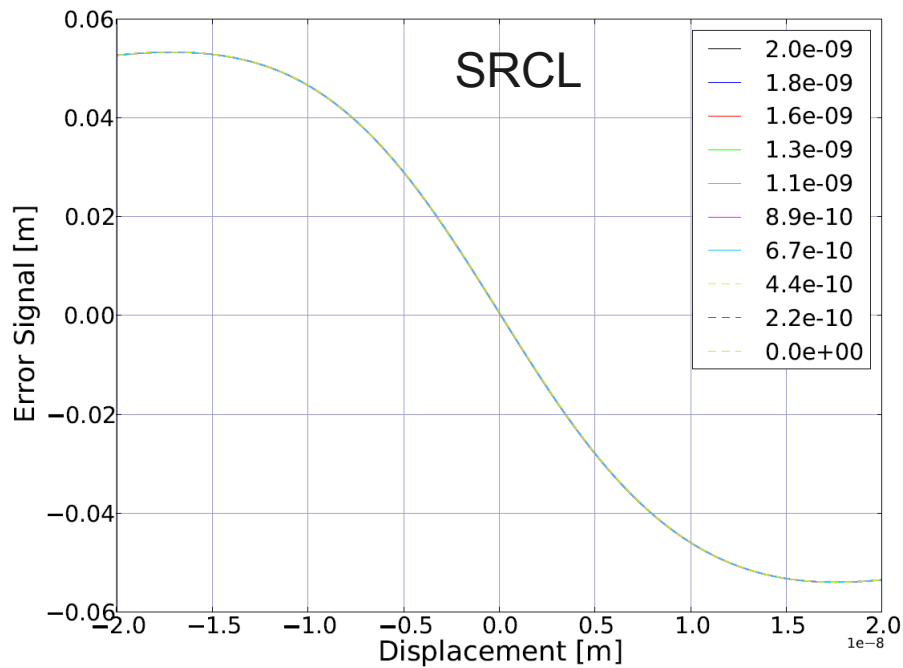
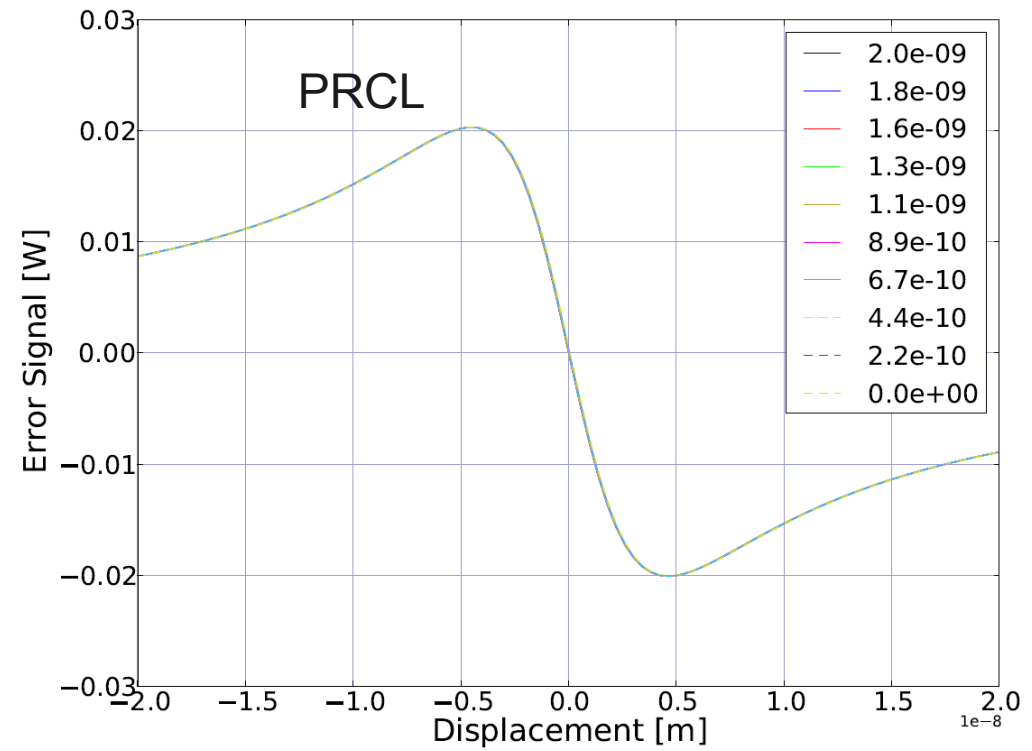

Detailed Optical Layout

Detailed optical layout design is a non-trivial task !

We have to ...

- Take into account wedge deflection
- Make the two arms at the right angle
- Track the optical path length (for SB resonant conditions)
- Track the Gaussian mode evolution
- Track the Gouy phase evolution
- Take into account the dispersion effect for the green beams
- Trace secondary beams (AR reflected)
- Generate CAD files

A python package to do the above job was developed.
gtrace: A Gaussian ray tracing library
(Validation of the library was done by Chen Dan)

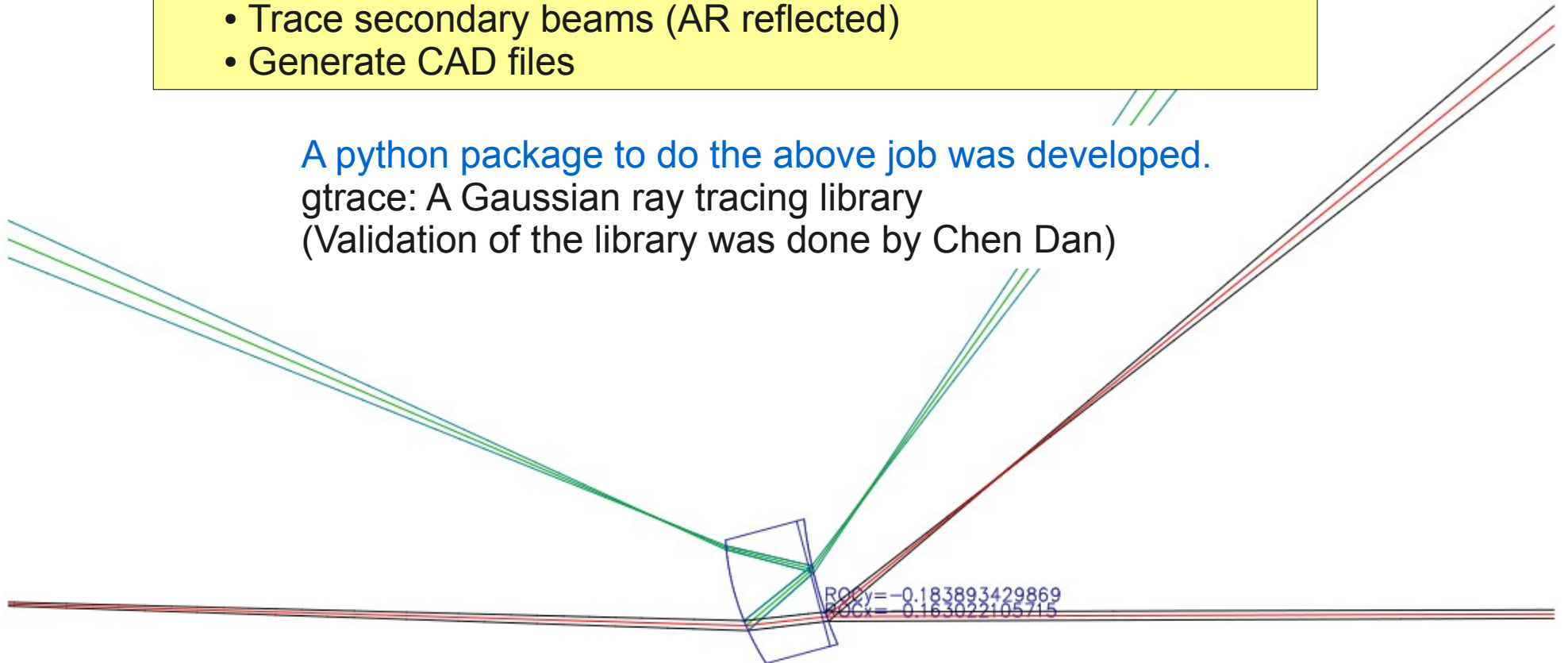

- iLCGT has to be on the way to bLCGT
- Minimum detour from the straight path to bLCGT
- Most parameters are the same as bLCGT

Interferometer Configuration

- Fabry-Perot Michelson Interferometer (no recycling)
- Arm cavity finesse is the same as bLCGT

Mirrors

- Test masses are fused silica
- All the other mirrors are to be used in bLCGT (BS and the folding mirrors)
- PRM is a blank with curvature (for mode matching)
- No SRM installed.

LSC

- A simple frontal modulation scheme using f1 SB only

ASC

- Wave front sensing at REFL and AS

LSC

	DARM	CARM	MICH
AS_1I	1	1.7×10^{-3}	1.0×10^{-3}
REFL_1I	8.8×10^{-3}	1	1.3×10^{-4}
REFL_1Q	4.5×10^{-3}	5.5×10^{-5}	1

ASC (Diagonalized)

	CSOFT	CHARD	DSOFT	DHARD
REFL_2IB	1	0	-8.7×10^{-5}	-1.8×10^{-4}
REFL_2IA	0	1	1.3×10^{-3}	8.7×10^{-5}
AS_1QB	-2.5×10^{-5}	3.4×10^{-6}	1	0
REFL_1QA	1.3×10^{-4}	-2.4×10^{-5}	0	1

What to do next ?

ASC and Folding Optimization

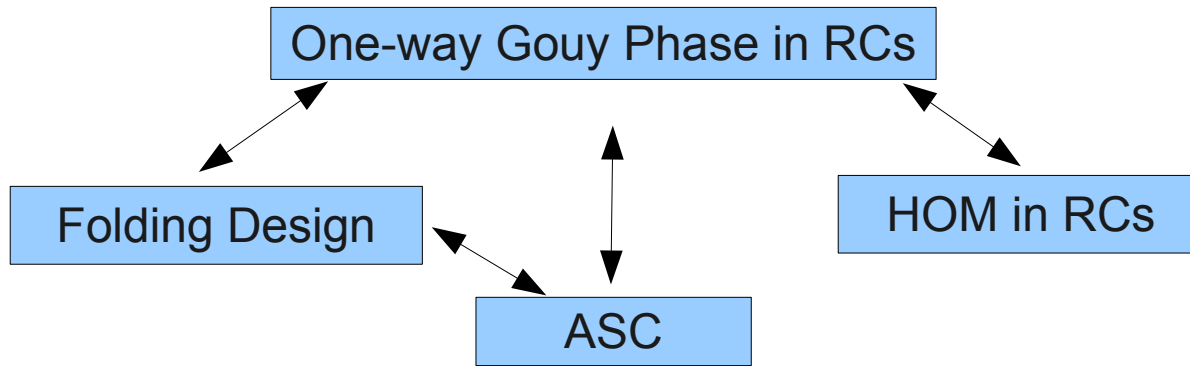

Technical Noise Couplings

- Laser Noise (frequency, intensity)
- Modulator phase noise
- Actuator noise (hierarchical control)
- PD noise
- etc



Requirements to other subsystems

OMC Design (together with the IOO group)

- Requirements (HOM reduction ratio)
- Control Schemes
- Prototype test

Simulated IFO plant

- Expedite the commissioning
- Make effective use of tunnel excavation & vacuum installation period (2 years)

Develop a computer model of the IFO

- Connected to the digital control system
- Develop the LSC & ASC digital servo system before actual interferometer is available
- Once real interferometer is installed, use the pre-developed servo system

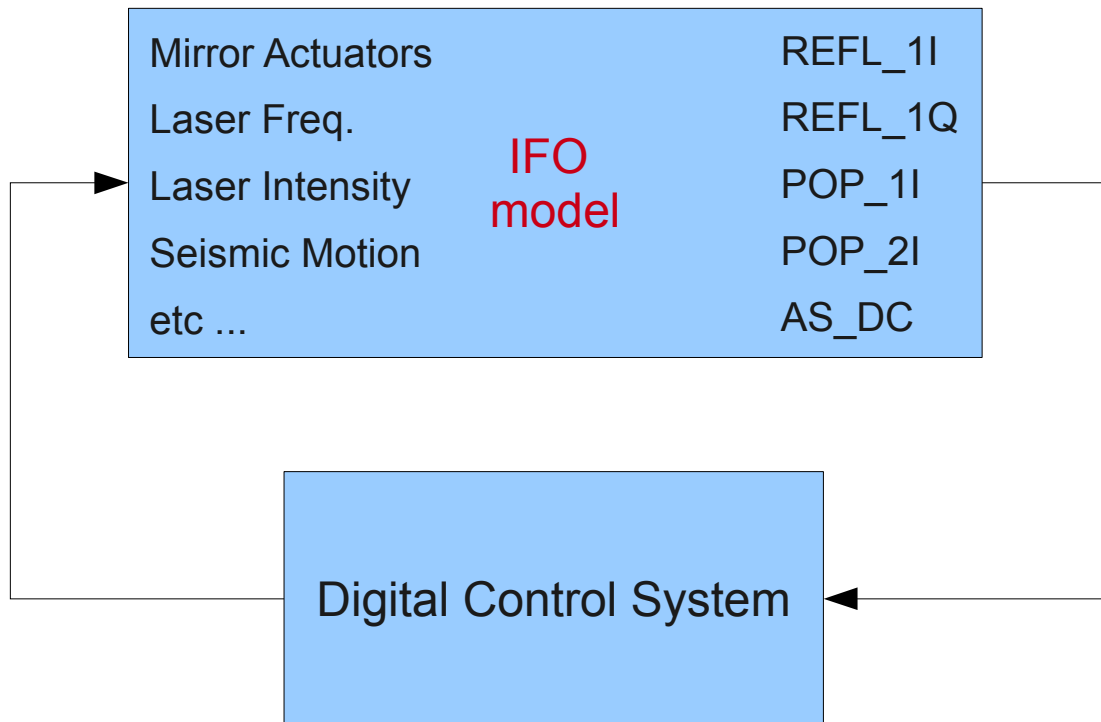

Linear Model

Model Generation: Optickle
Implementation: Digital System

Non-Linear Model

Time-domain simulation: e2e
Non-realtime
Simulate lock acquisition etc..

Schedule

Commissioning Period

Tasks	FY2013												FY2014												FY2015											
	8	9	10	11	12	1	2	3	4	5	6	7	8	9	10	11	12	1	2	3	4	5	6	7	8	9	10	11	12	1	2	3				
FPMI	[Red]																																			
X-arm	[Blue]			[Blue]			[Blue]			[Blue]			[Blue]			[Blue]			[Blue]			[Blue]			[Blue]			[Blue]			[Blue]			[Blue]		
Y-arm	[Blue]			[Blue]			[Blue]			[Blue]			[Blue]			[Blue]			[Blue]			[Blue]			[Blue]			[Blue]			[Blue]			[Blue]		
MI	[Blue]			[Blue]			[Blue]			[Blue]			[Blue]			[Blue]			[Blue]			[Blue]			[Blue]			[Blue]			[Blue]			[Blue]		
FPMI	[Blue]																																			
Noise hunting	[Blue]																																			
Observation	[Blue]																																			
RSE1	[Red]																																			
Preparation	[Blue]																																			
DRMI	[Blue]																																			
PRFPMI	[Blue]																																			
RSE	[Blue]																																			
Observation	[Blue]																																			
RSE2	[Red]																																			
VIS Upgrade	[Blue]																																			
RSE	[Blue]																																			
Observation	[Blue]																																			

Tasks	FY2016												FY2017											
	4	5	6	7	8	9	10	11	12	1	2	3	4	5	6	7	8	9	10	11	12	1	2	3
CRSE	[Red]																							
Installation of Cryogenic System	[Blue]												[Blue]											
Single Arm Tests	[Blue]												[Blue]											
FPMI	[Blue]																							
RSE	[Blue]																							
Noise hunting	[Blue]																							
Observation	[Red]																							
Noise Hunting	[Blue]																							

Risks

- Arm loss may be higher --> PRC becomes under coupled
 - Prepare several PRMs with slightly different reflectivities
- Arm loss may be smaller
 - Shot noise increase of the DDM signals
- HD phase depends on the amount of reflectivity mismatch between the arms
 - DARM offset may have to be very large
 - HD phase may be almost 90 deg.
- SRC detuning by offset
- PR3 ROC error
 - Leave room for moving PRM, PR2, PR3, SRM, SR2 and SR3
- ASC design
 - How to control the folded PRC/SRC ?
- OMC design
 - Control Schemes

Summary

Interferometer Design (bLCGT)

- RSE interferometer
- Variable BRSE/DRSE
- 66m folded recycling cavities

Length Control Scheme

- 16.875MHz-45MHz PM, Single demodulation
- Optional Non-Resonant Sideband

Alignment Sensing Scheme

- WFS & Optical Lever
- Needs more study

Lock Acquisition

- Green laser pre-lock
- Third harmonics demodulation or NRS

TO DO

- Alignment Sensing Schemes
- Folding design optimization
- OMC design
- Technical noise couplings
- Simulated IFO plant

Interferometer Design (iLCGT)

- Fabry-Perot Michelson
- No Recycling