

干渉計デザインの現状

2010/8/31, Y. Aso

現状要約

- 建設へ向けた各種パラメータの決定作業
(以下、青字はだいたい決まったもの)
- トンネルや真空計設計に必要な情報 --- 長さ
- 鏡発注に必要な情報 --- 鏡の大きさ、反射率、曲率、ウェッジ、許容誤差
- 鏡の大きさに関しては、干渉計側からの要求値と、二つのプランを提示
鏡グループ及び防振グループで検討してもらっている
- 光学レイアウト作成中 (麻生)
 - Foldingは行う
 - 腕は傾く: 干渉計は全て(傾いた)同一平面内に配置
- アライメント制御計算中 (我妻、宮川)
- リスク項目洗い出し(宗宮)

他のグループとの協議事項

- 真空パイプ、輻射シールド部分の太さ
- 低温真空槽のView Port (干渉計側からは絶対必要)
- グリーンコーティング (可能か?)

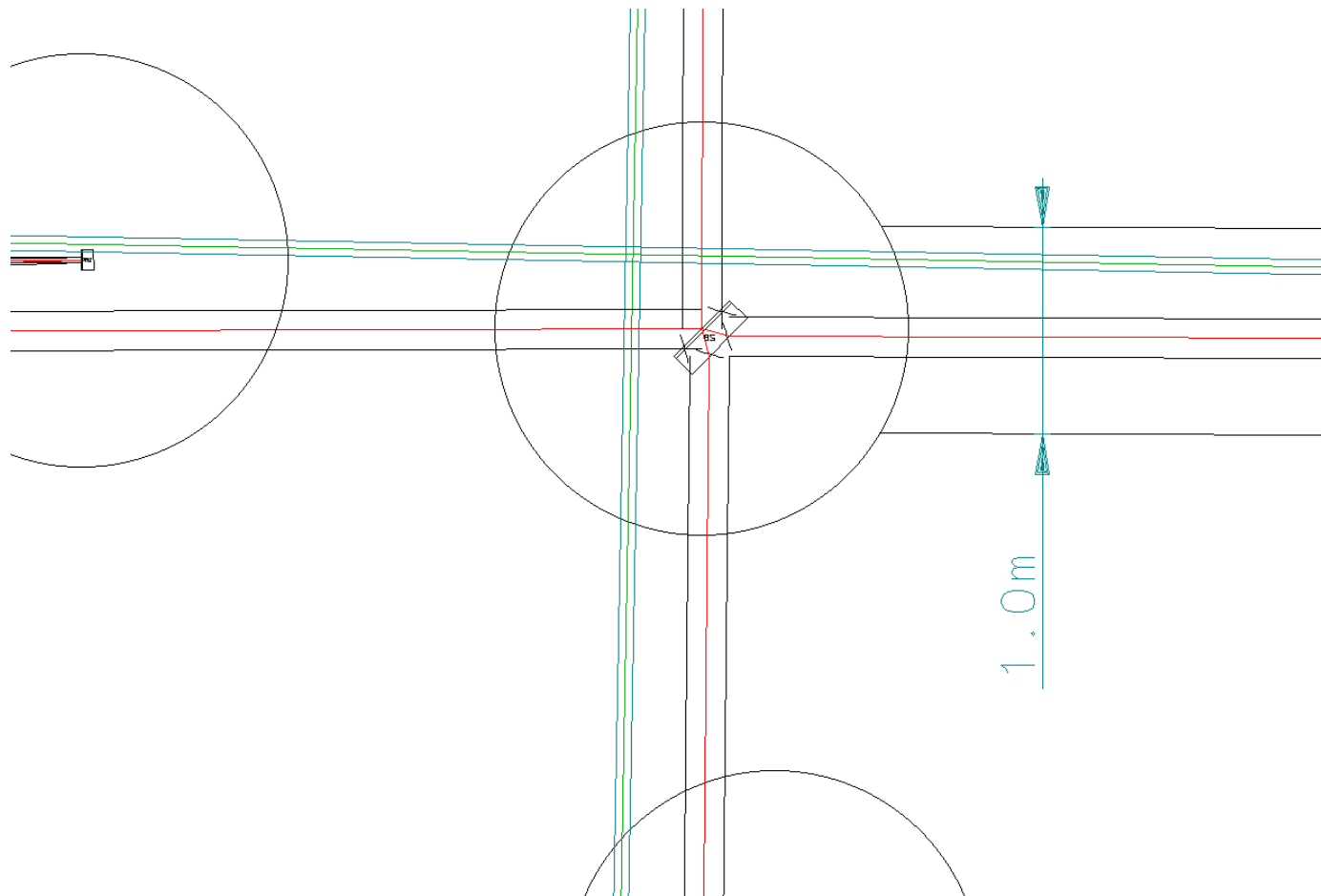

What do we have to design ?

3rd year and final design

- We have to design both 3rd year IFO and the final IFO.
- In the first half of this document, I will focus on the final IFO.
- The 3rd year configuration should be designed reflecting the final IFO configuration.
- Therefore, we have to decide on the final design first.

Parameters necessary for mirror order and tunneling

- Arm cavity parameters
 - Finesse
 - g-factor (Mirror ROCs)
 - Mirror Size
 - AR wedge
 - Error specs
- Recycling Cavity Designs
 - RM reflectivities
 - Lengths
 - Folding design
- Beam splitter design
 - Size
 - Wedge

We also have to design:

- Length sensing and control scheme
- Alignment sensing and control scheme

There are many factors to consider to decide on the parameters and the scheme.

Arm Cavity Parameters

Finesse: 1550 (already decided by the IFOBW WG)

Issues

- 1550 could be too high. Need more investigations on what could go wrong.

Mirror loss: 45ppm per reflection. Is it possible ?

g-factor: $\sqrt{1/3}$ --> $L=3000\text{m}$, $\text{ROC}=7098.08\text{m}$ (Conventional number)
 $-\sqrt{1/3}$ --> $L=3000\text{m}$, $\text{ROC}=1901.92\text{m}$ (Alternative)

Beam Size: 3.5cm for both cases

HOM degeneration: the same for both cases

Angular instability:

Two eigen-frequencies are 1.66Hz and 0.86Hz for a sapphire mirror
(Moment of inertia = $0.173 \text{ [kg}\cdot\text{m}^2]$)

For positive g, 1.66Hz becomes unstable while it is 0.86 for negative g.

Parametric Instability:

There are preferred regions in the g factor space from the view point of PI.

The regions are the same for positive and negative g.

However, dg/dR is different by a factor of 13 (negative g is larger).

Therefore, negative g is more sensitive to the ROC error (not limited to the PI actually).

PI calculation by K. Yamamoto

Positive g-factor

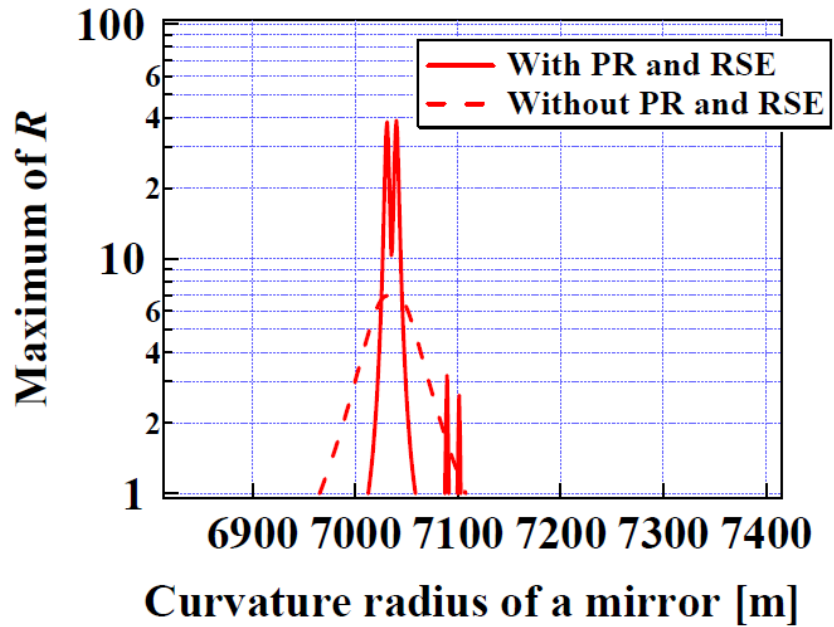

Negative g-factor

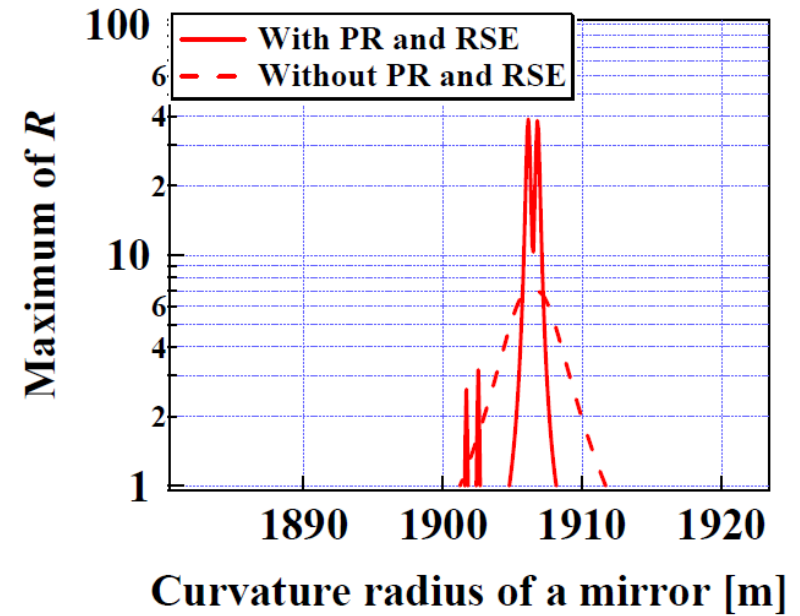

The error requirement on the mirror ROC is stricter for the negative g-factor.

Mirror Size

Factors to consider

- It is desirable to have as few as possible variations of size and weight of the mirrors from the view point of SAS
- Especially, changing the weight is costly.
- What is the maximum possible mirror size ?

Main Cavity Mirrors

Diameter=25cm, Thickness=15cm is the default

Weight is 16kg for Silica and 30kg for Sapphire

The beam diameter on the mirrors is 7cm. 25cm is larger than the 3σ diameter.

Compound mirror ? (see the next next page)

Recycling and Folding Mirrors

Diameter=25cm, Thickness=15cm, 16kg is the default

These mirrors can be smaller, but increasing mirror size variation is considered more costly at this moment (discussion needed).

Beam Splitter

Diameter=37cm, Thickness=6.85cm, 16kg is the default.

These numbers are chosen based on the H. Yamamoto's calculation shown on the next page.

The thickness is adjusted to have the same weight as the RMs.

Optical Loss in the PRC by BS size effect by H. Yamamoto

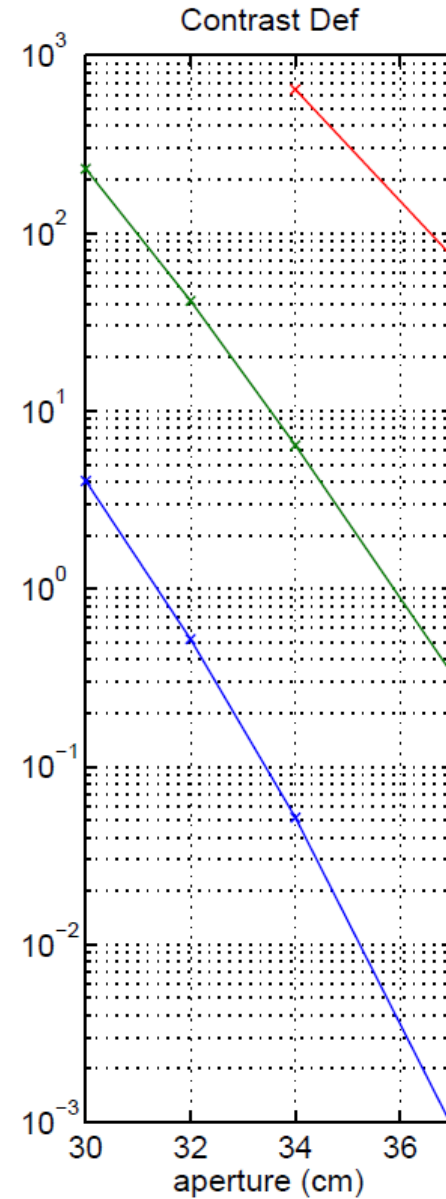
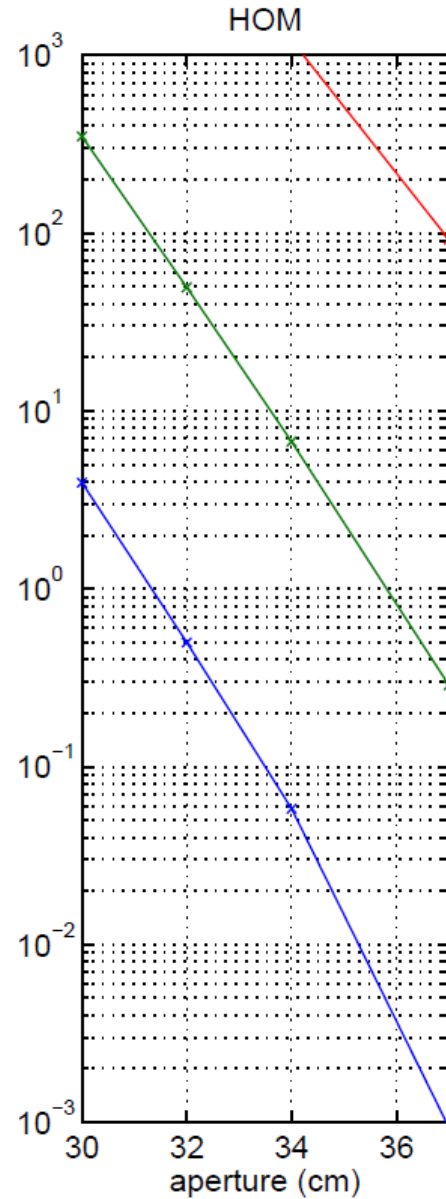
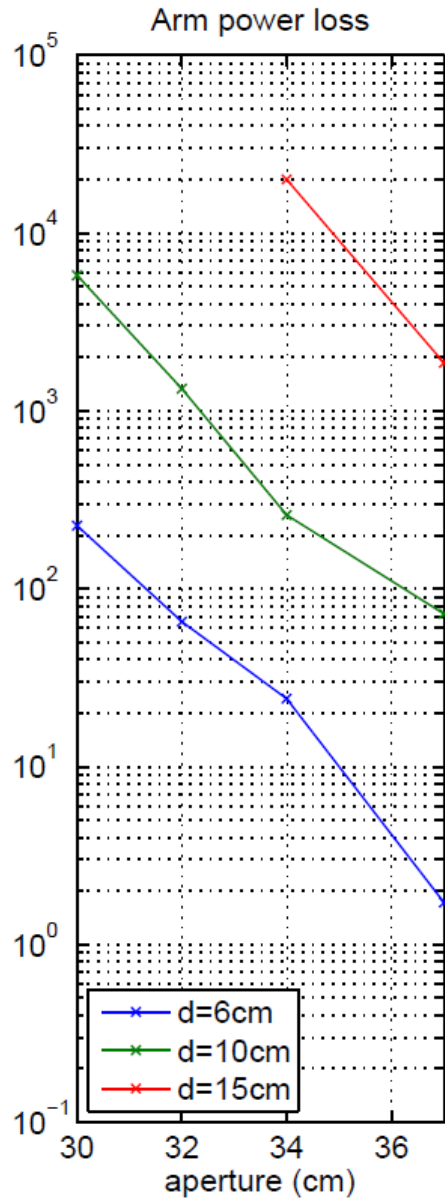

Compound Mirror Idea

by M. Ando (compiled by Y. Aso)

- The 3rd year IFO does not necessarily have an extremely good thermal noise
- By attaching a ring of heavy metal around a small fused silica mirror, we may make a 25cm mirror with the same weight as the final sapphire one.
- We can use Type-A SAS from the beginning (no replacement required)
- Thermal noise has to be checked.

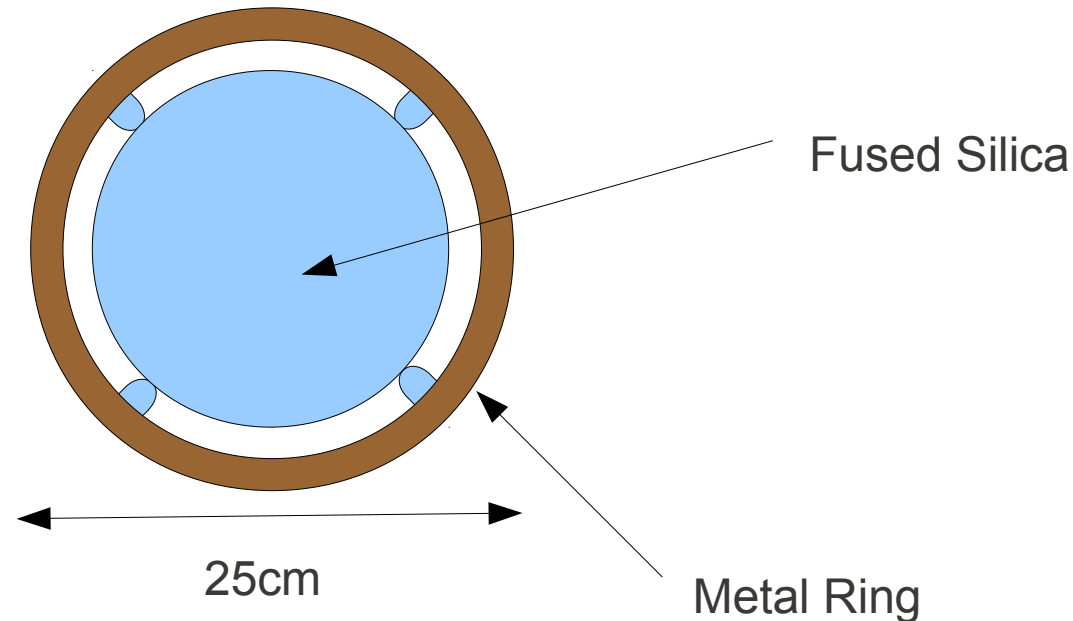

Example:

Using Copper.

Silica diameter = 18.9cm.

Copper ring outer diameter = 25cm, inner diameter = 19.9cm

Total Weight = 30kg

Wedge

Functions of wedge

- To avoid forming an Etalon between the AR and HR surfaces
- To separate secondary reflections from the main beam

ITMs & PRM

- These are now curved mirrors --> no Etalon formed.
- Wedge is still needed for picking up the secondary reflections (no pick-off mirror is planned to be installed at this moment)

BS

- Wedge is necessary to separate the secondary reflection from the main beam.

Issues

- Is it possible to make wedge on a sapphire mirror ?
- When the mirror substrate is changed, the wedge angle must be changed because the deflection angle depends on the refraction index.

Other Mirror Specs

- AR reflectivity
- Error tolerances for various parameters

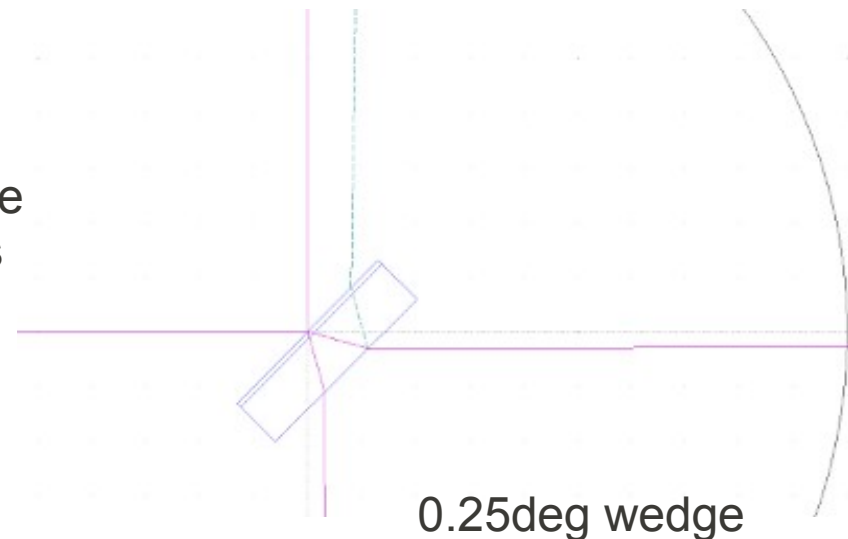

Recycling Cavity Design

Background

A straight recycling cavity would be marginally stable for the LCGT parameter. This can introduce many unwanted side-effects.

A solution to this is to stabilize it by adding extra Gouy phase shift inside.

For the moment, the Gouy phase shift in the RCs are designed to be 20deg one-way. This is a rough number taken from aLIGO's design.

Folding Cavity Design

The RCs are folded by two additional curved mirrors to add extra Gouy phase shift.

Issues

- Mode matching between the RC and the arm cavities depends strongly on the distance between the two folding mirrors.
- We need a mechanism to adjust the position of the folding mirrors.
- Is it possible to polish a large mirror to a small ROC ?
- Scattered light by the folding mirrors
 - The scattered light power was estimated by D. Tatsumi
 - We have to convert this to actual contamination of the error signals.

Recycling Cavity Design continued

What is the optimal Gouy phase shift ?

- A very stable PRC would suppress the WFS signal from the arm cavities.
- We have to hit a balance between the RC stability and the WFS signal strength.
- 20deg is probably not a bad number but most likely not the optimal one.
- We need the ASC calculation and the GW signal loss estimation by MIST (or Finesse) to answer the above question.

For the moment, if we decide to fold the RCs, the locations of the folding mirrors are fixed by the geometric constraints coming from the minimization of the astigmatism. Fine adjustment of the Gouy phase can be done by changing the ROC of the folding mirrors.

I/O Length Sensing and Control

- A basic scheme is found
- Not sure it is the optimum one
- Needs a cross check

Alignment Sensing and Control

What is the status, Agatsuma-kun ?

Lock Acquisition

Basic ideas for green laser lock

- Green Lasers are injected from PR3 for X-arm, and SR3 for Y-arm
- PR3, SR3 and BS are transparent to green.
- ITMs and ETMs are dichroic mirrors
- Each green laser is locked to the main laser through a PLL
- Additional AOM could be inserted between the green lasers and PLL to provide fast frequency actuation

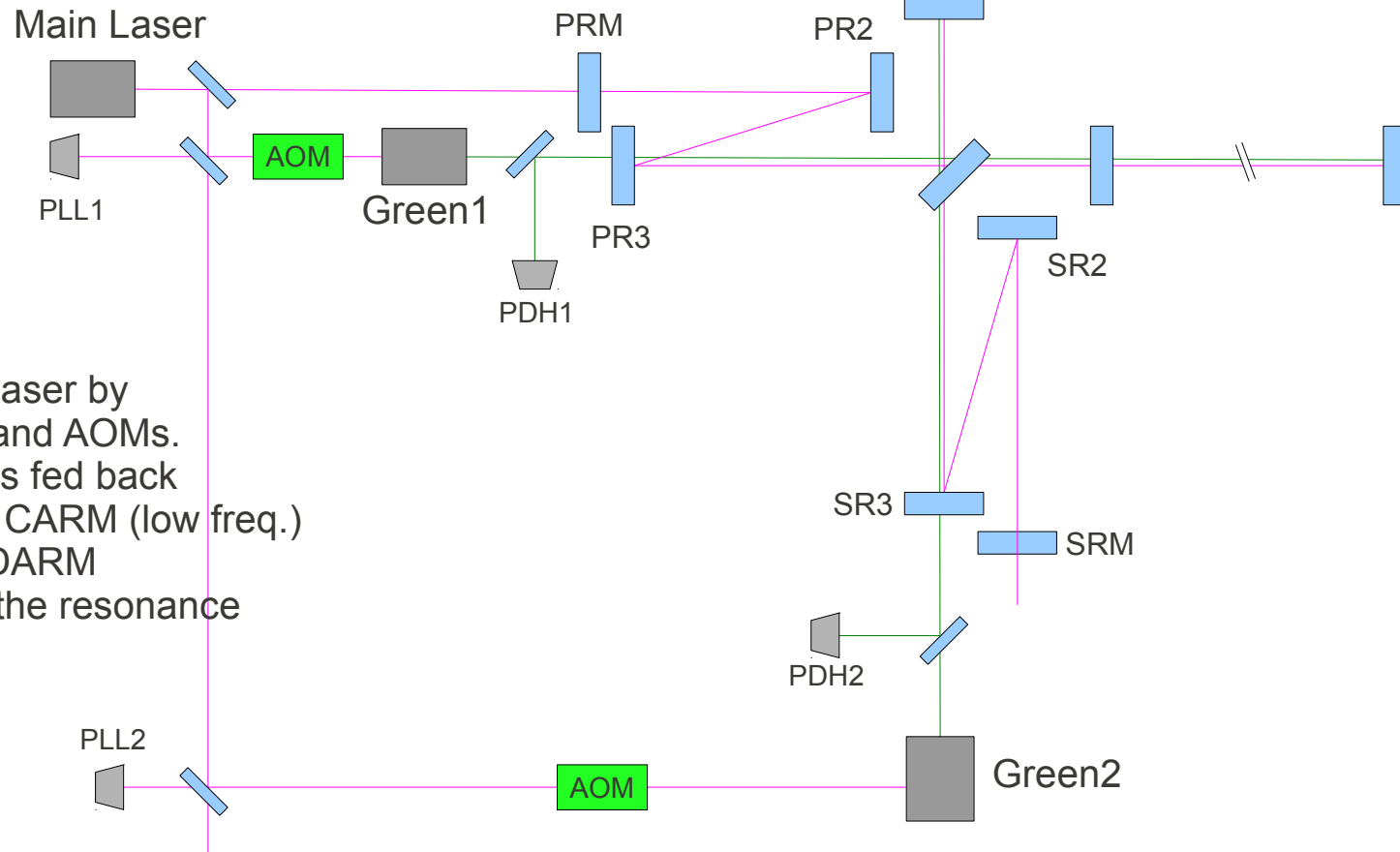

Lock procedure

- Each arm is locked to the green laser by frequency feedback to the PLLs and AOMs.
- Common signal of the two arms is fed back to the main laser (high freq.) and CARM (low freq.)
- Differential signal is fed back to DARM
- Scan the PLL1 and PLL2 to find the resonance of the main laser

Interfaces with other subsystems

Suspension

We need:

- Realistic seismic attenuation performance including alignment

We provide:

- Actuator requirements (noise, strength)
- Local sensor requirements
- Optical Layout

Input & Output Optics

We provide:

- Requirements for the laser power
- Sideband frequencies and power
- Input mode shape
- Intensity and frequency noise requirements

Digital & Analog Electronics

We provide:

- Number of signal ports & actuation points
- Electric noise requirements
- RF noise requirements

Interfaces with other subsystems continued

Vacuum and Cryogenic System

We provide:

- Strongly request to make view ports
- Optical Layout

Mirror Group

We need:

- Producible mirror sizes
- Realizable accuracy of ROC
- Realizable loss (including absorption and scatter)

We provide:

- Mirror Size (as soon as possible)
- Detailed mirror specs including error tolerance

Optical Layout Tool

- A python module to automatically compute the propagation, reflection, deflection of Gaussian beams.
- Programmatic design of the IFO optical layout to satisfy various quantitative requirements at the same time

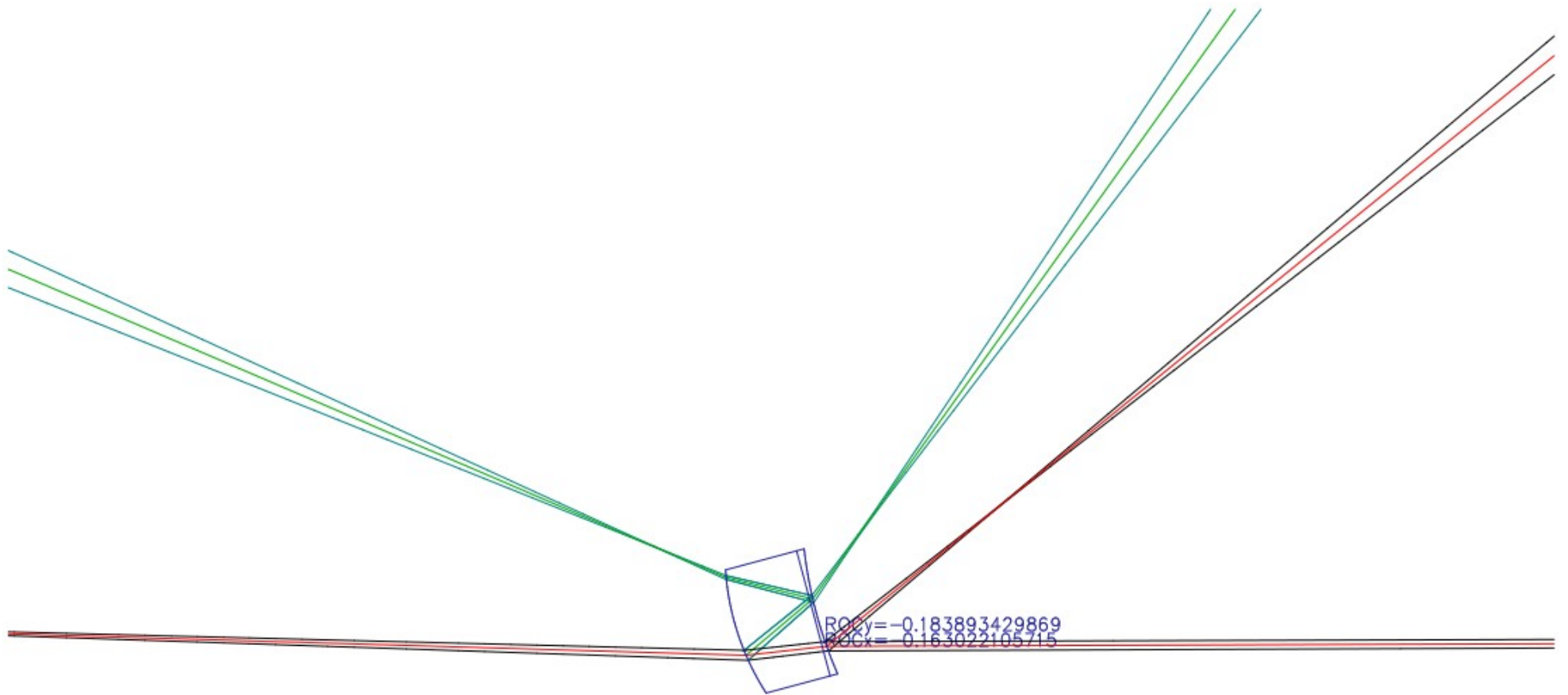

Risks and Concerns

A draft list by Somiya and Miyakawa

- (1) ロスのインバランスが小さすぎてHD位相が90度に固定されてしまう
～ aLIGOではBAEをしないのでLCGT特有という意味でリスク
- (2) DRSEにしたときにf1にインバランスができて誤差信号にオフセット
～ PD出力がサチる、非線形雑音など、aLIGOが避けたリスクを負う
- (3) 入射光学系でAMを作ったりMZを入れたりすると変な雑音に乗る
～ これもaLIGOが避けた問題
- (4) f1とf2の比が近いのがなんとなく危険
～ aLIGOより比が小さい
- (5) DDMのPDは作れるのか
～ aLIGOはSDMのみ
- (6) OMC-REFLから信号がきれいにとれるのか(LA問題、高次モードなど)
～ aLIGOでは使わない
- (7) 折り返しの散乱光vs折り返さない場合のSBモード縮退
～ 折り返すならaLIGOと同じリスク、折り返さないなら特有リスク
- (8) フィネスが高い→(1)と逆にHD位相が0度に近くなる可能性
～ aLIGOでは下げている
- (9) VRSEにするためにlsとl-が下がる
→(6)が失敗するときつい
→DRSEだとFFがとれないかもしれないので厳しくなる
- (10) PM-PMのときのLA方法が確立されていない
- (11) OMCの共振は大丈夫か
- (12) サファイアITMは作れるか
- (13) サファイア鏡とファイバーはくっつくか

Risks and Concerns continued

(14) 1.8mm径のファイバーが作れるか

(15) サファイアで45ppmの光損失は可能か

(16) (15)はコーティングの機械損失が低温で上がるかという意味だったかも

(17) 7kmもしくは1.9kmのROCが実現できるか

(18) RM2のROC→なんでしたっけ、これ